

## GROUP 4 MECHATRONICS SYSTEM (CLUSTER TYPE 1)

### 1. ALL ACTUATORS SPEED ARE SLOW

- ※ Boom, Arm, Bucket, Swing and travel speed are slow, but engine speed is good.
- ※ Spec : P-mode 2100 ± 50 rpm    S-mode 2000 ± 50 rpm    E-mode 1900 ± 50 rpm  
 (HCEC engine : P-mode 1950 ± 50 rpm    S-mode 1850 ± 50 rpm    E-mode 1750 ± 50 rpm)
- ※ Before carrying out below procedure, check all the related connectors are properly inserted and fault code on the cluster.

#### 1) INSPECTION PROCEDURE

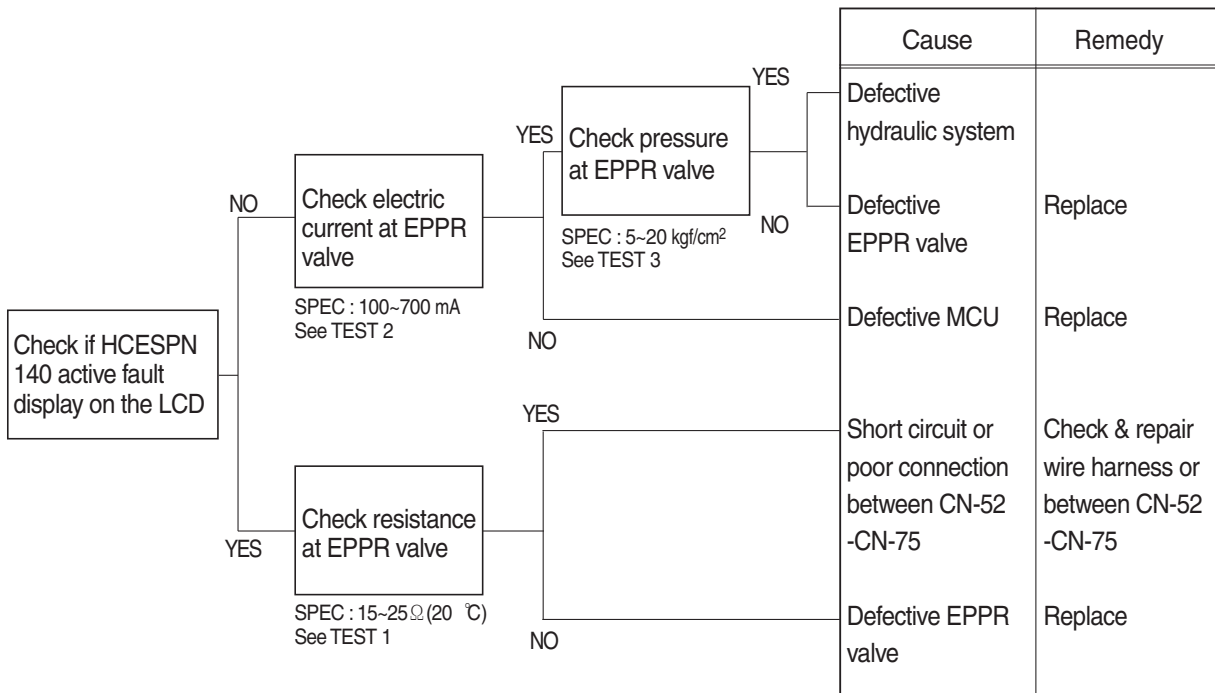

#### Wiring diagram

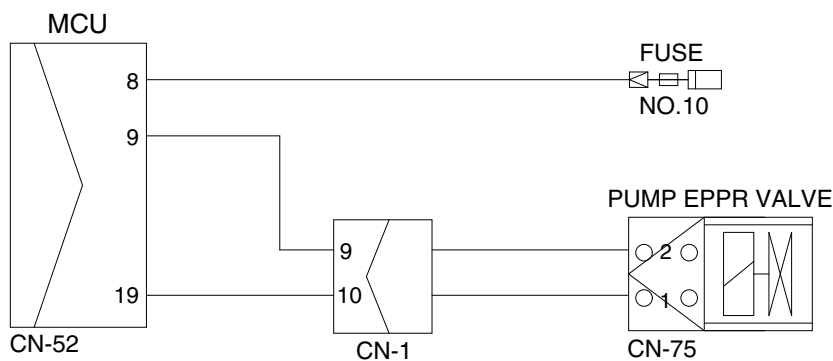

## 2) TEST PROCEDURE

(1) **Test 1** : Check resistance at connector CN-75.

- ① Starting key OFF.
- ② Disconnect connector CN-75 from EPPR valve at main hydraulic pump.
- ③ Check resistance between 2 lines as figure.

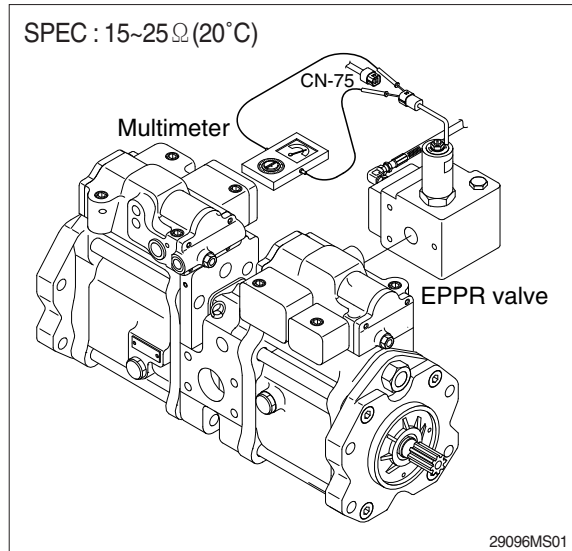

(2) **Test 2** : Check electric current at EPPR valve.

- ① Install multimeter as figure.
- ② Start engine.
- ③ Set the accel dial at "10" (MAX)
- ④ Set S-mode and cancel auto decel mode.
- ⑤ If tachometer show approx  $2000 \pm 50$  rpm (HCEC engine :  $1850 \pm 50$  rpm), check electric current.

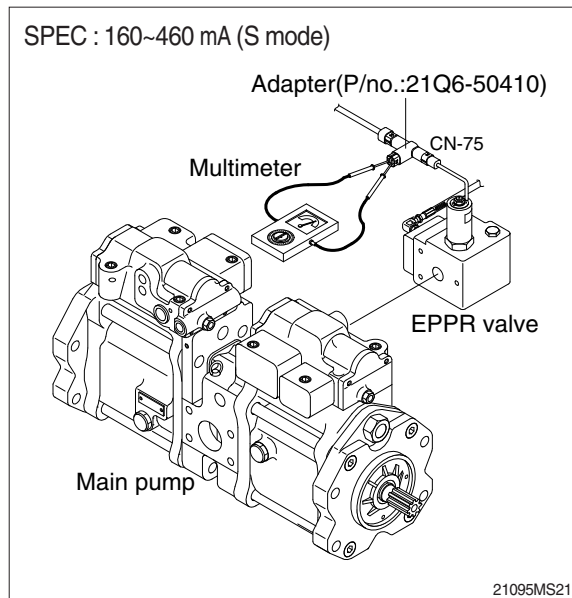

(3) **Test 3** : Check pressure at EPPR valve.

- ① Remove plug and connect pressure gauge as figure.
  - Gauge capacity : 0 to 50 kgf/cm<sup>2</sup>  
(0 to 710 psi)
- ② Start engine.
- ③ Set the accel dial at "10" (Max).
- ④ Set S-mode and cancel auto decel mode.
- ⑤ If tachometer show approx  $2000 \pm 50$  rpm (HCEC engine :  $1850 \pm 50$  rpm), check pressure.
- ⑥ If pressure is not correct, adjust it.
- ⑦ After adjust, test the machine.

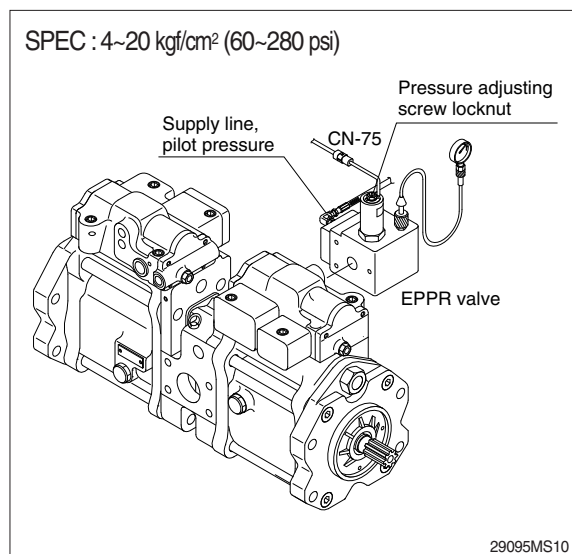

## 2. ENGINE STALL

※ Before carrying out below procedure, check all the related connectors are properly inserted.

### 1) INSPECTION PROCEDURE

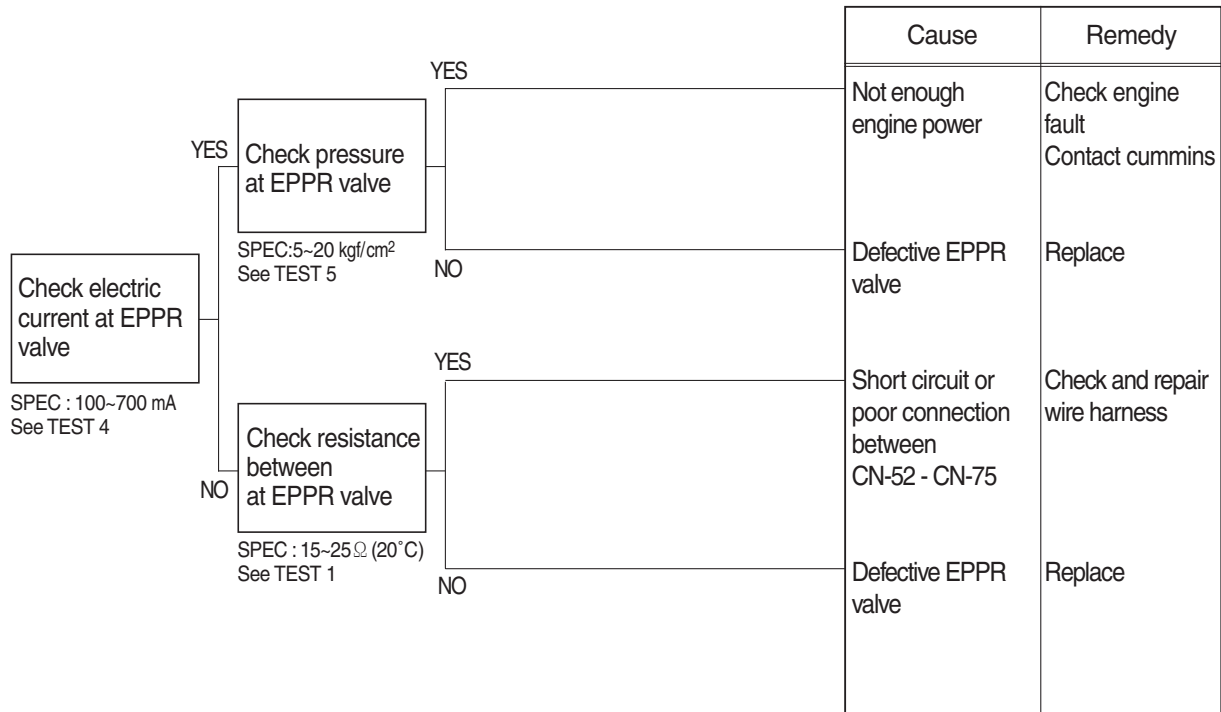

### Wiring diagram

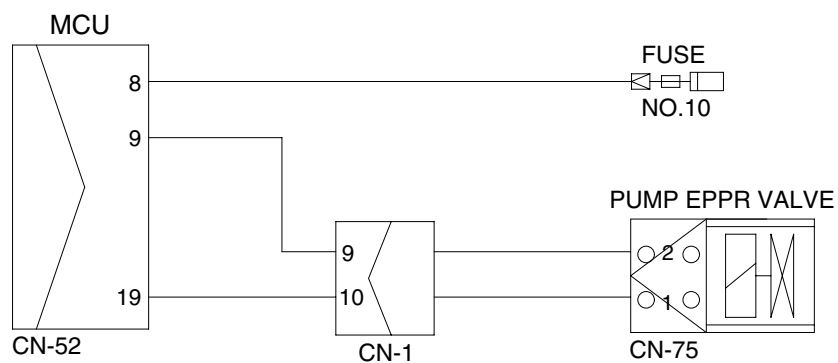

3009SH6MS01

## 2) TEST PROCEDURE

(1) **Test 4** : Check electric current at EPPR valve at S-mode

- ① Install multimeter as figure.
- ② Start engine.
- ③ Set the accel dial at "10" (max)
- ④ Set S-mode with  $2000 \pm 50$  rpm (HCEC engine :  $1850 \pm 50$  rpm).
- ⑤ Check electric current.

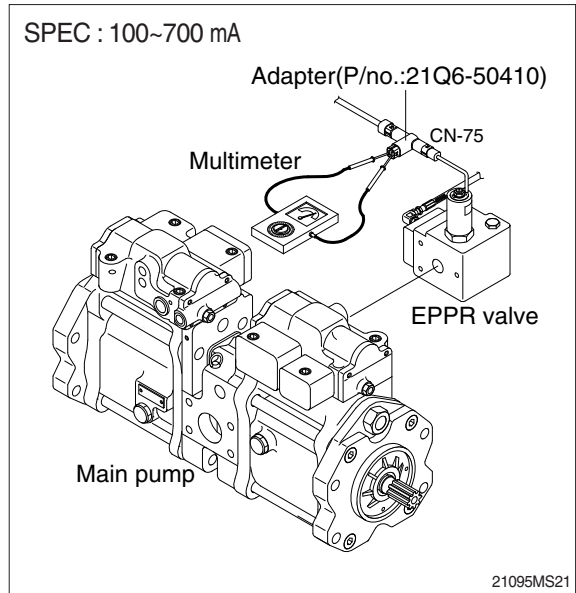

(2) **Test 5** : Check pressure at EPPR valve at S-mode

- ① Connect pressure gauge at EPPR valve.
- ② Start engine.
- ③ Set the accel dial at "10" (max)
- ④ Set S-mode with  $2000 \pm 50$  rpm (HCEC engine :  $1850 \pm 50$  rpm).
- ⑤ Operate bucket lever completely push or pull.
- ⑥ Hold arm lever at the end of stroke.
- ⑦ Check pressure at relief position.

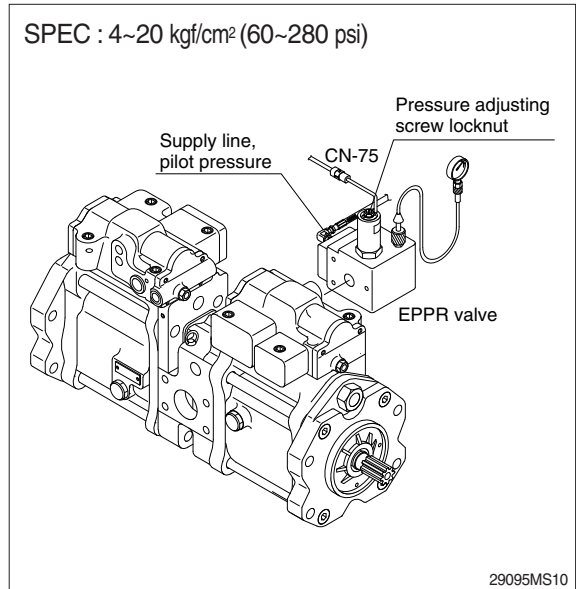

### 3. MALFUNCTION OF CLUSTER OR MODE SELECTION SYSTEM

※ Before carrying out below procedure, check all the related connectors are properly inserted.

#### 1) INSPECTION PROCEDURE

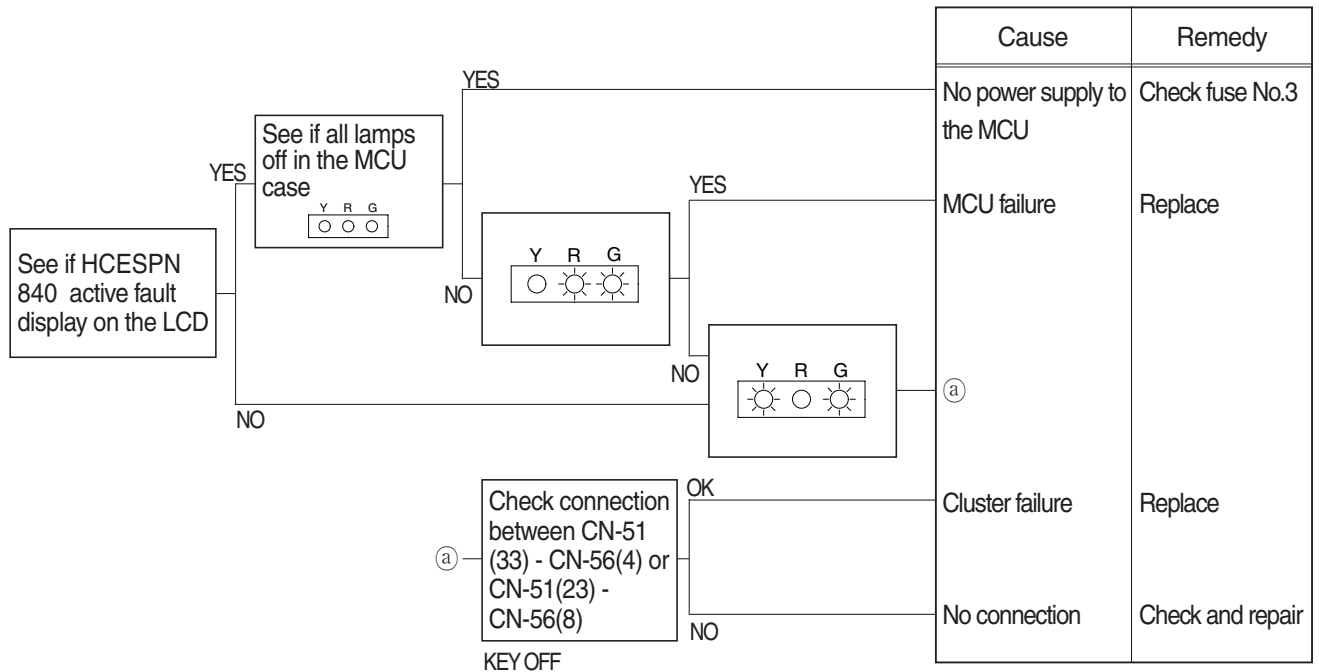

#### Wiring diagram

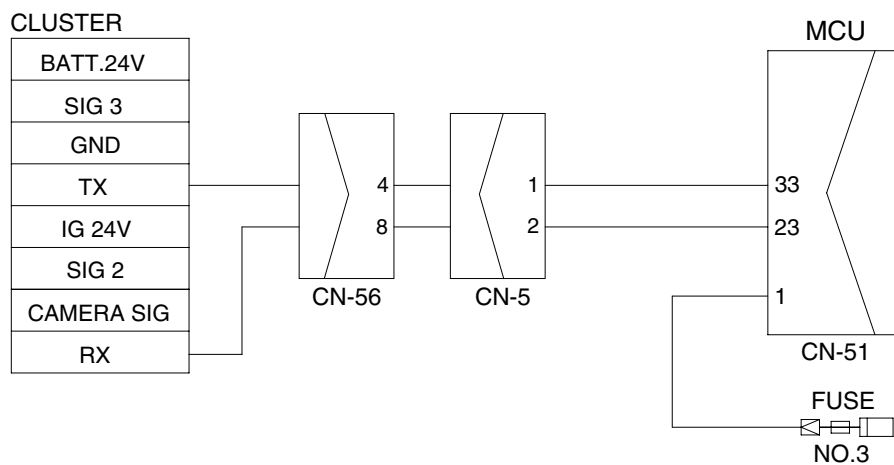

3009SH6MS02

#### 4. MALFUNCTION OF ACCEL DIAL

※ Before carrying out below procedure, check all the related connectors are properly inserted.

##### 1) INSPECTION PROCEDURE

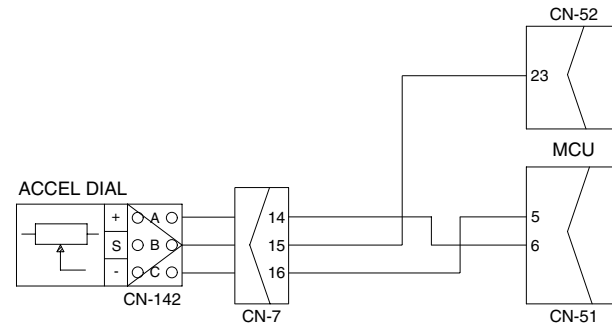
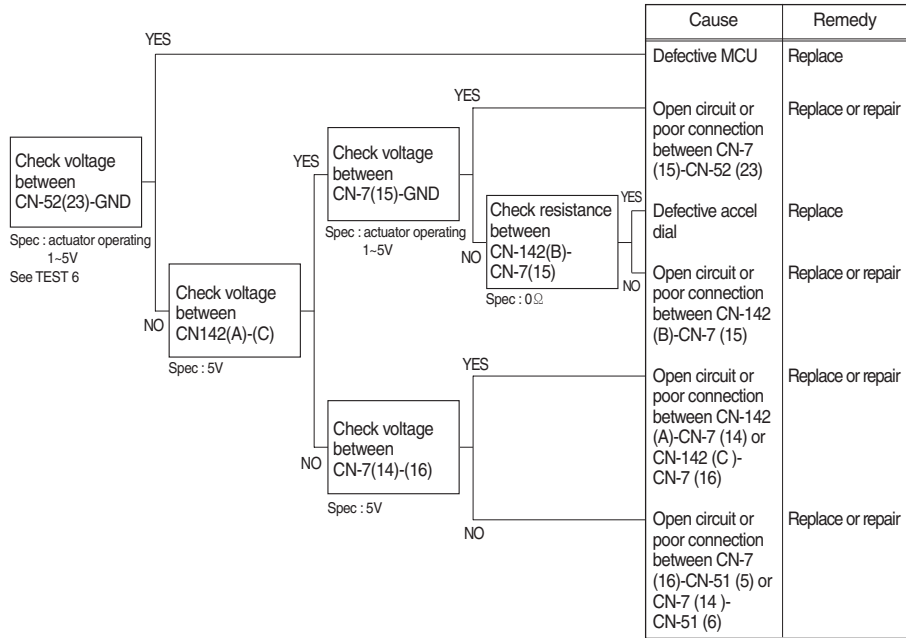

## 2) TEST PROCEDURE

(1) **Test 6** : Check voltage at CN-52(23) and ground.

- ① Prepare 1 piece of thin sharp pin, steel or copper.
- ② Insert prepared pin to rear side of connectors : One pin to (23) of CN-52.
- ③ Starting key ON.
- ④ Check voltage as figure.

SPEC : Actuator operating : 1~5 V

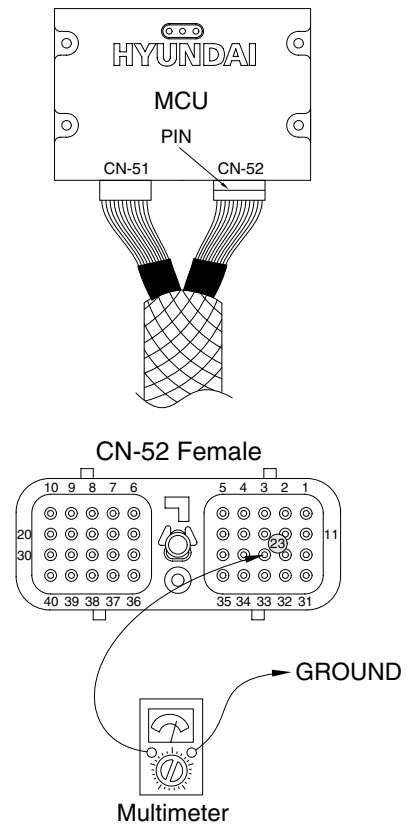

3009SH6MS04

## 5. AUTO DECEL SYSTEM DOES NOT WORK

- Fault code : HCESPN 105, FMI 0~4 (work pressure sensor)  
HCESPN 108, FMI 0~4 (travel oil pressure sensor)

※ Before carrying out below procedure, check all the related connectors are properly inserted.

### 1) INSPECTION PROCEDURE

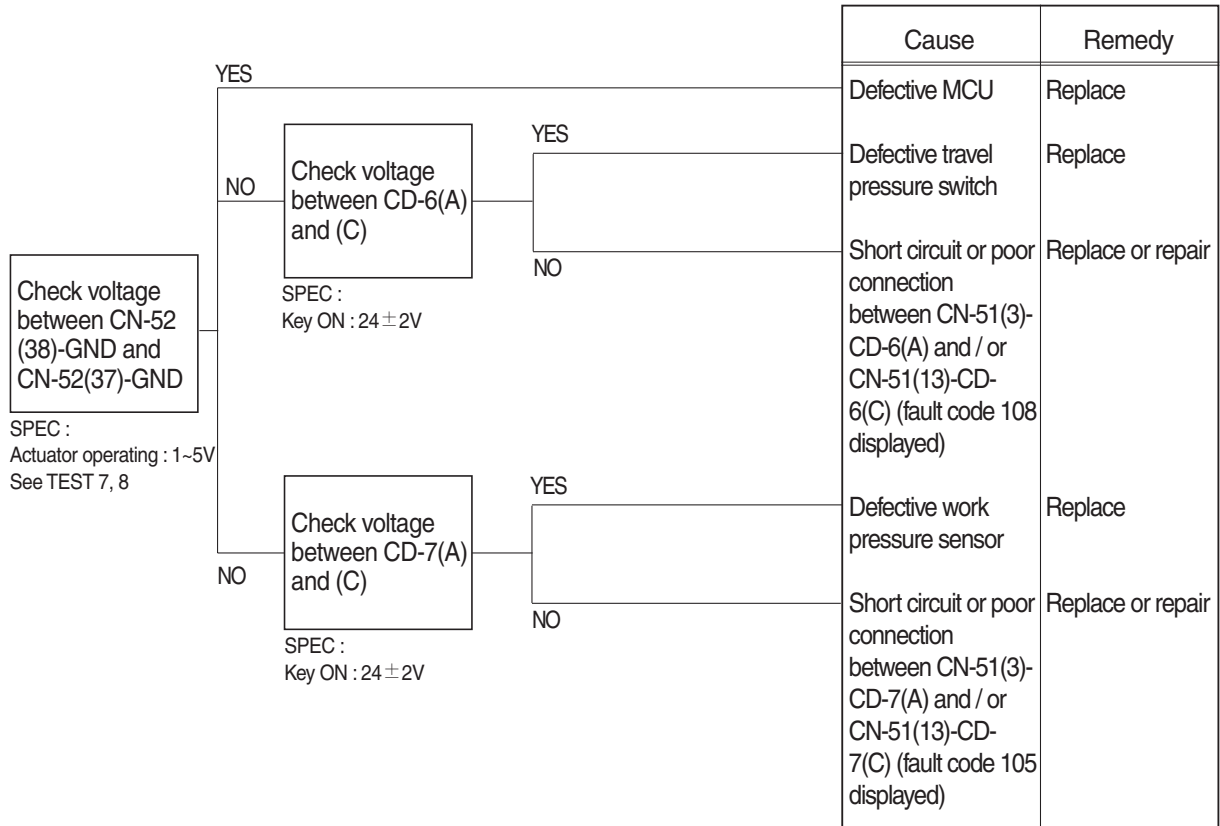

### Wiring diagram

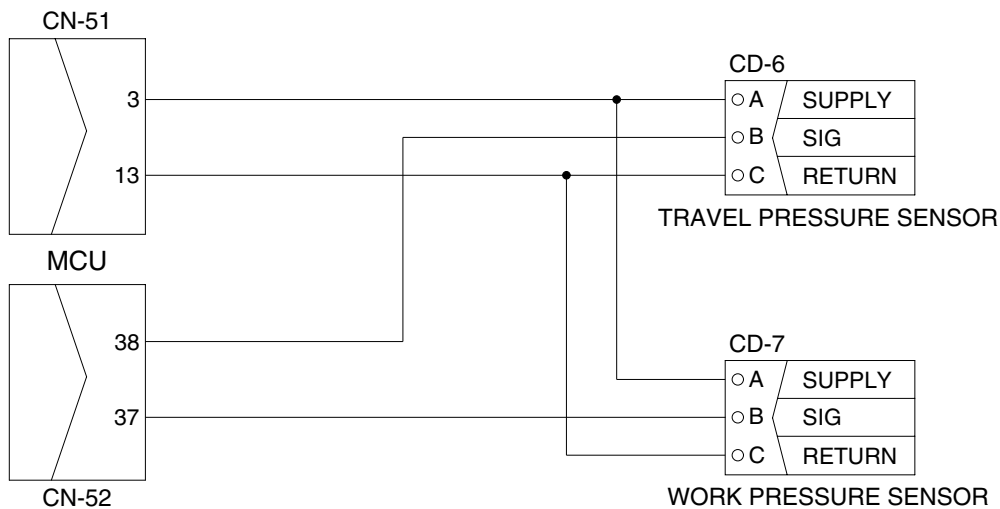

3009SH6MS05



## 2) TEST PROCEDURE

(1) **Test 7** : Check voltage at CN-52(38) and ground.

- ① Prepare 1 piece of thin sharp pin, steel or copper.
- ② Insert prepared pin to rear side of connectors : One pin to (38) of CN-52.
- ③ Starting key ON.
- ④ Check voltage as figure.

(2) **Test 8** : Check voltage at CN-52(37) and ground.

- ① Prepare 1 piece of thin sharp pin, steel or copper
- ② Insert prepared pin to rear side of connectors : One pin to (37) of CN-52.
- ③ Starting key ON.
- ④ Check voltage as figure.

SPEC : Actuator operating : 1~5 V

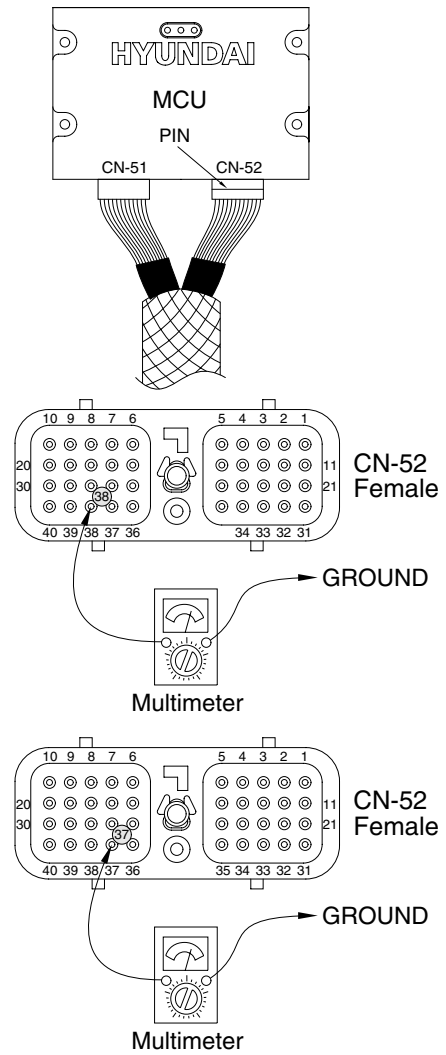

3009SH6MS06

## 6. MALFUNCTION OF PUMP 1 PRESSURE SENSOR

· Fault code : HCESPN 120, FMI 0~4

※ Before carrying out below procedure, check all the related connectors are properly inserted.

### 1) INSPECTION PROCEDURE

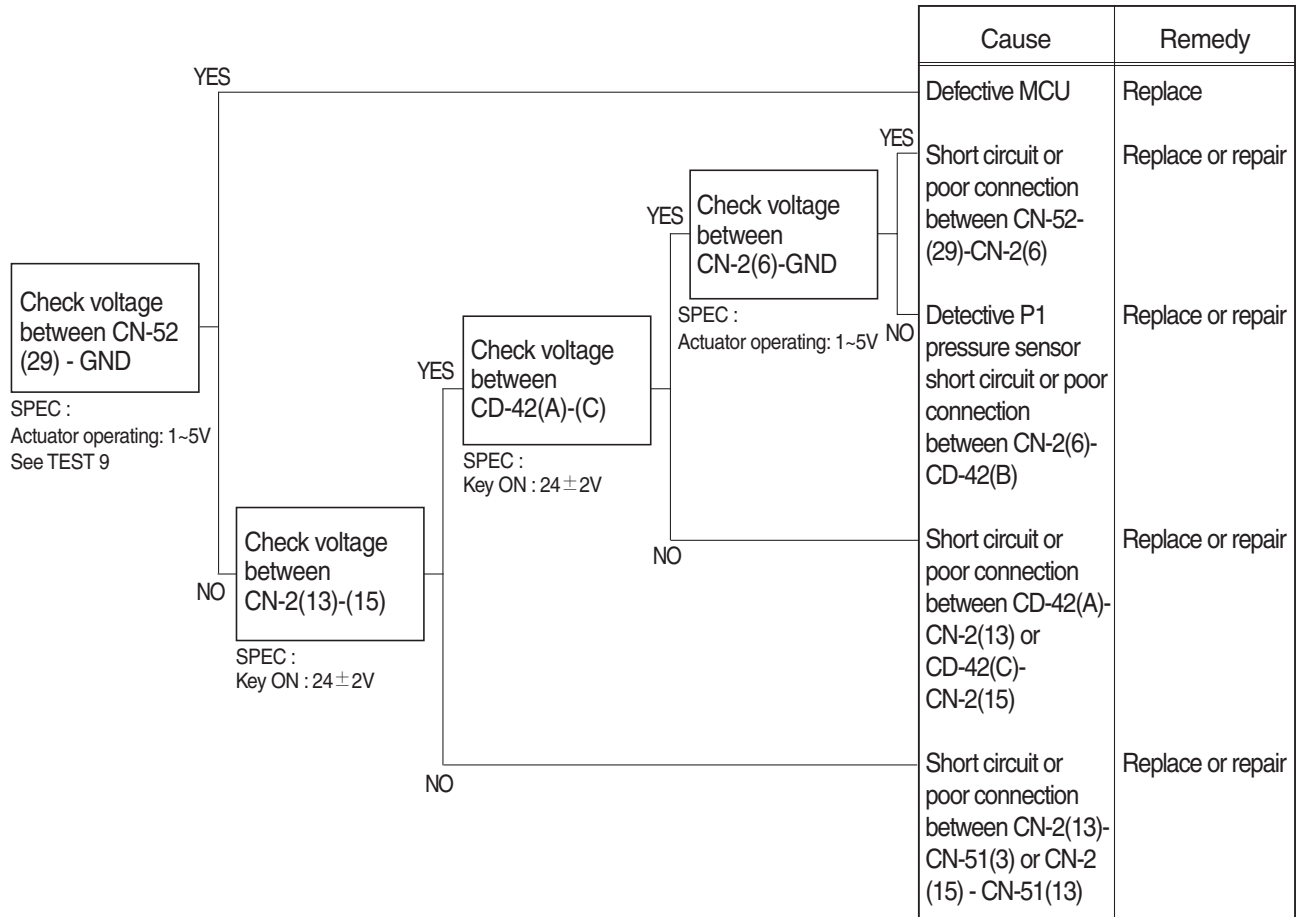

### Wiring diagram

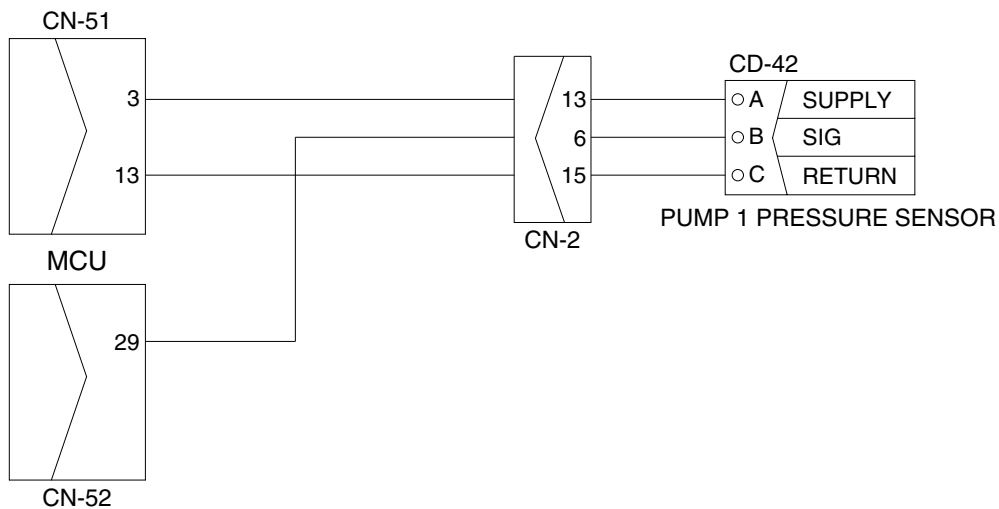

3009SH6MS07

## 2) TEST PROCEDURE

(1) **Test 9** : Check voltage at CN-52(29) and ground.

- ① Prepare 1 piece of thin sharp pin, steel or copper.
- ② Insert prepared pin to rear side of connectors : One pin to (29) of CN-52.
- ③ Starting key ON.
- ④ Check voltage as figure.

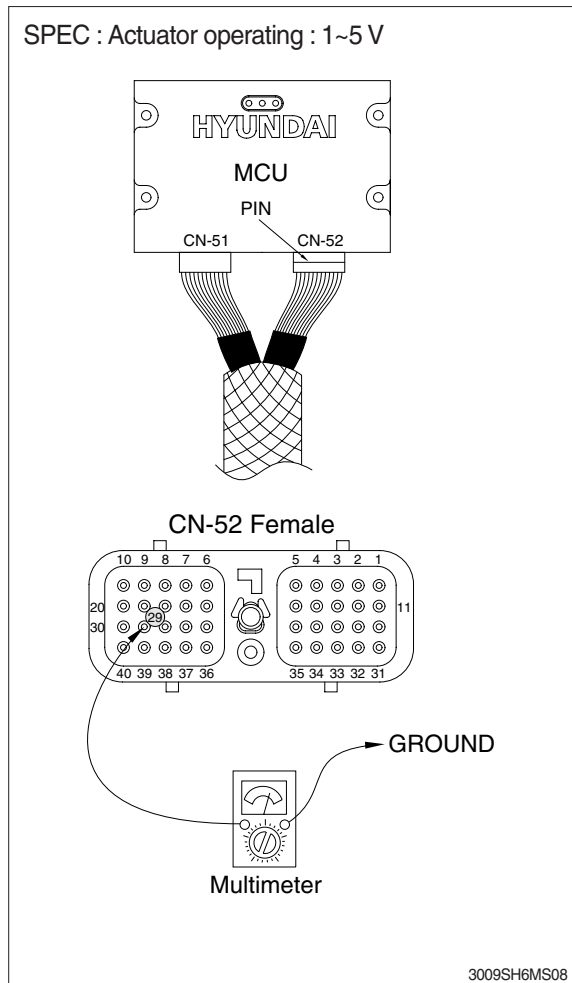

## 7. MALFUNCTION OF PUMP 2 PRESSURE SENSOR

· Fault code : HCESPN 121, FMI 0~4

※ Before carrying out below procedure, check all the related connectors are properly inserted.

### 1) INSPECTION PROCEDURE

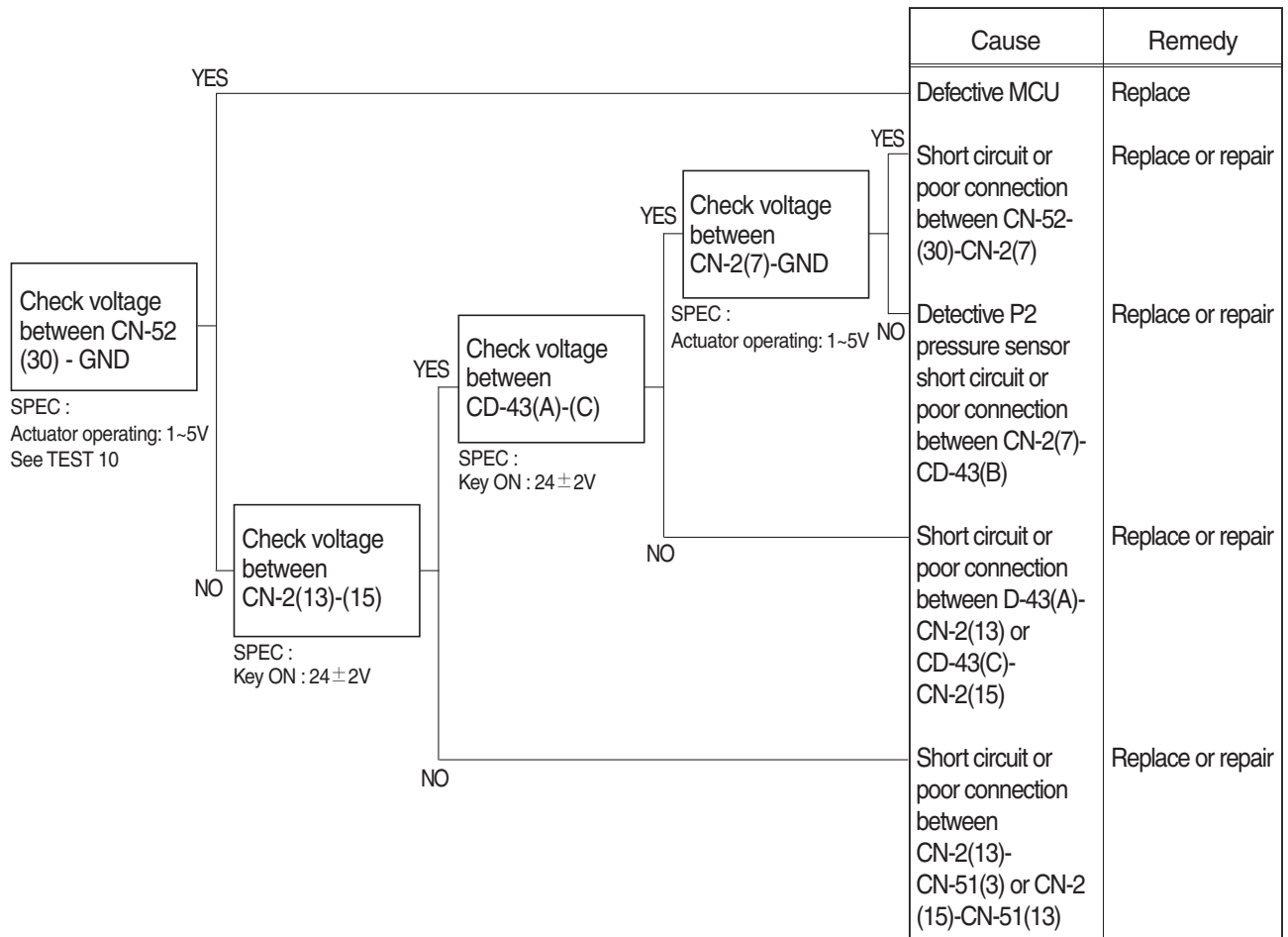

### Wiring diagram

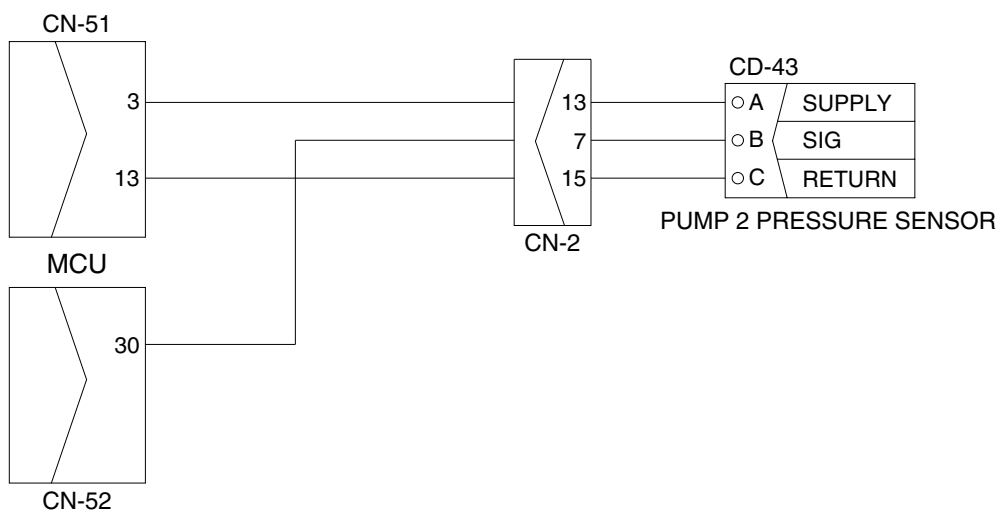

## 2) TEST PROCEDURE

(1) Test 10 : Check voltage at CN-52(30) and ground.

- ① Prepare 1 piece of thin sharp pin, steel or copper.
- ② Insert prepared pin to rear side of connectors : One pin to (30) of CN-52.
- ③ Starting key ON.
- ④ Check voltage as figure.

SPEC : Actuator operating : 1~5 V

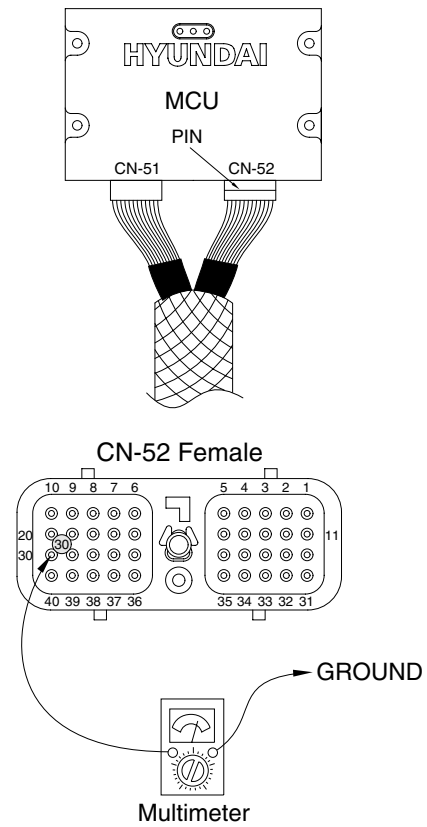

3009SH6MS10

## 8. MALFUNCTION OF PUMP 3 PRESSURE SENSOR

· Fault code : HCESPN 125, FMI 0~4

※ Before carrying out below procedure, check all the related connectors are properly inserted.

### 1) INSPECTION PROCEDURE

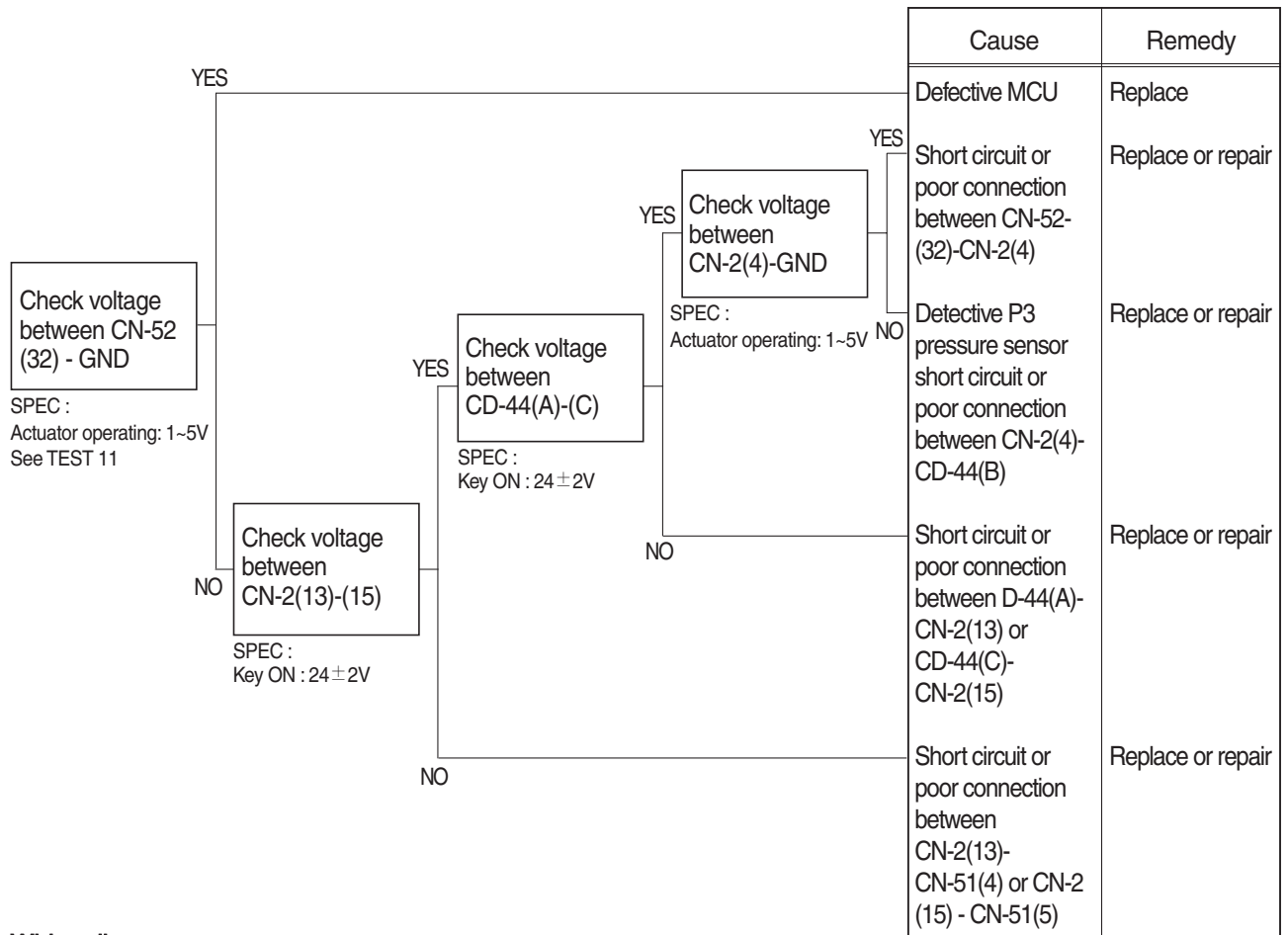

### Wiring diagram

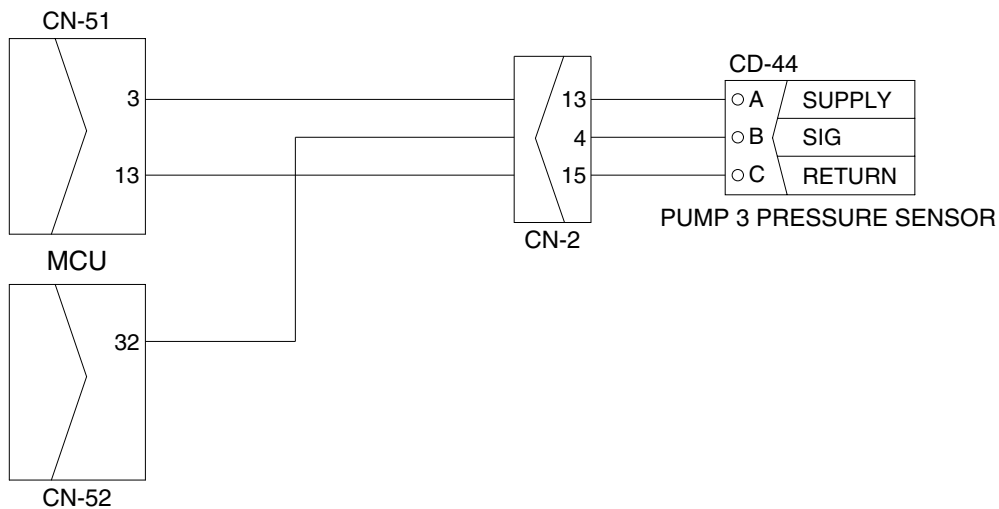

3009SH6MS11

## 2) TEST PROCEDURE

(1) **Test 11** : Check voltage at CN-52(32) and ground.

- ① Prepare 1 piece of thin sharp pin, steel or copper.
- ② Insert prepared pin to rear side of connectors : One pin to (32) of CN-52.
- ③ Starting key ON.
- ④ Check voltage as figure.

SPEC : Actuator operating : 1~5 V

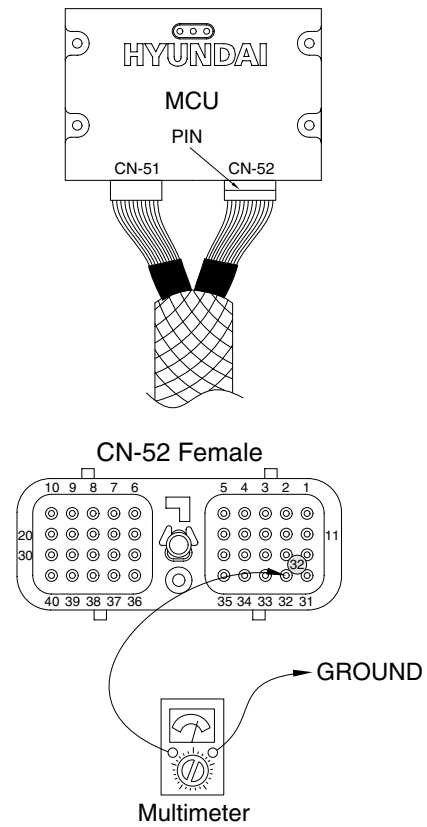

3009SH6MS12

## 9. MALFUNCTION OF SWING PRESSURE SENSOR

· Fault code : HCESPN 135, FMI 0~4

※ Before carrying out below procedure, check all the related connectors are properly inserted.

### 1) INSPECTION PROCEDURE

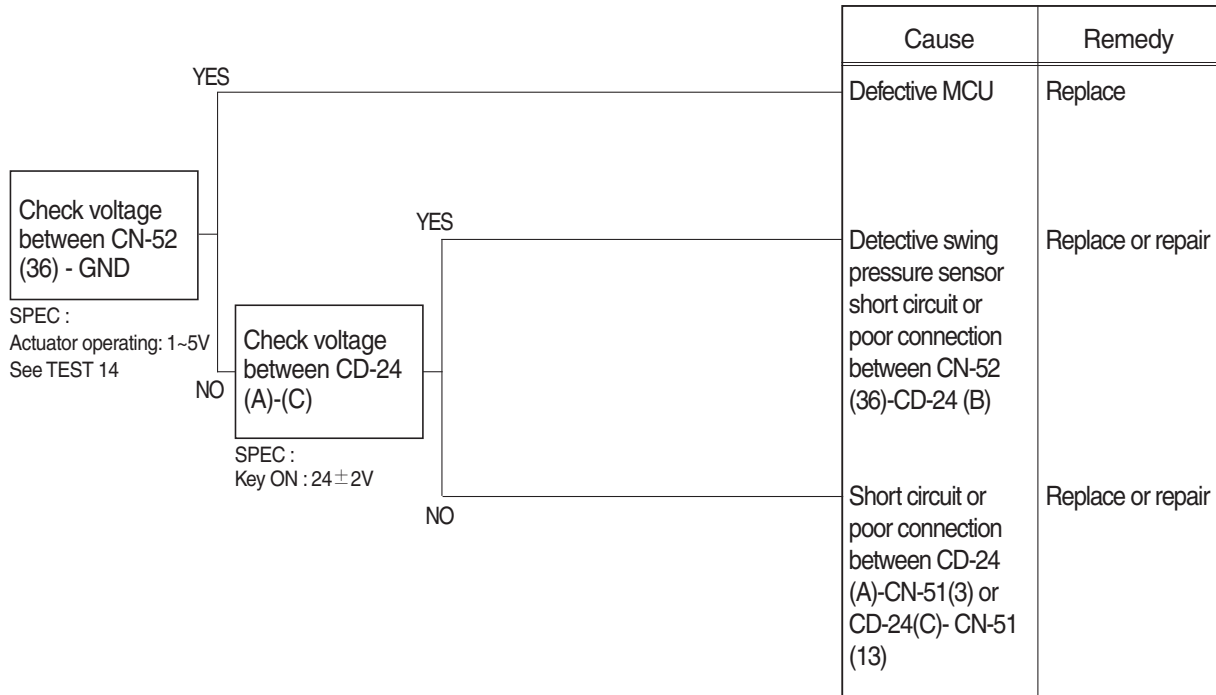

### Wiring diagram

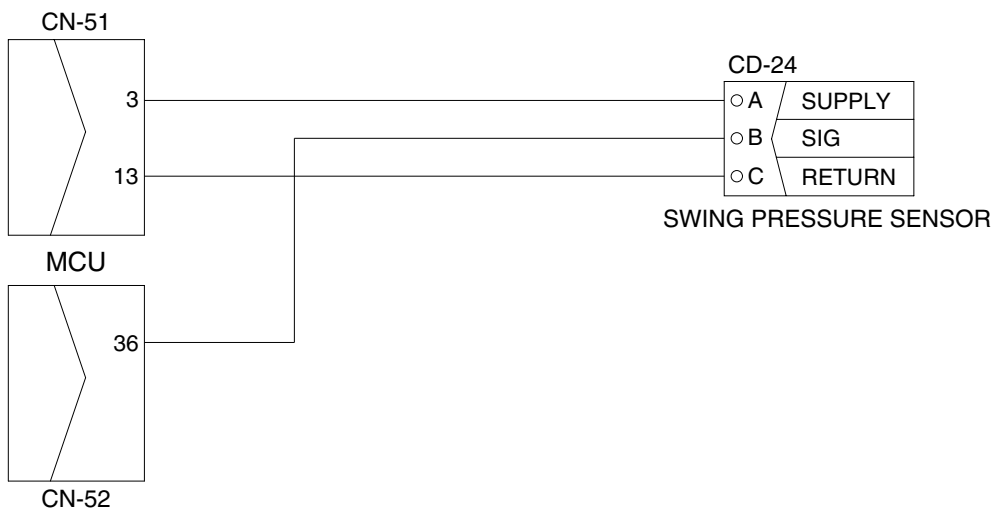

3009SH6MS13



## 2) TEST PROCEDURE

(1) Test 14 : Check voltage at CN-52(36) and ground.

- ① Prepare 1 piece of thin sharp pin, steel or copper.
- ② Insert prepared pin to rear side of connectors : One pin to (36) of CN-52.
- ③ Starting key ON.
- ④ Check voltage as figure.

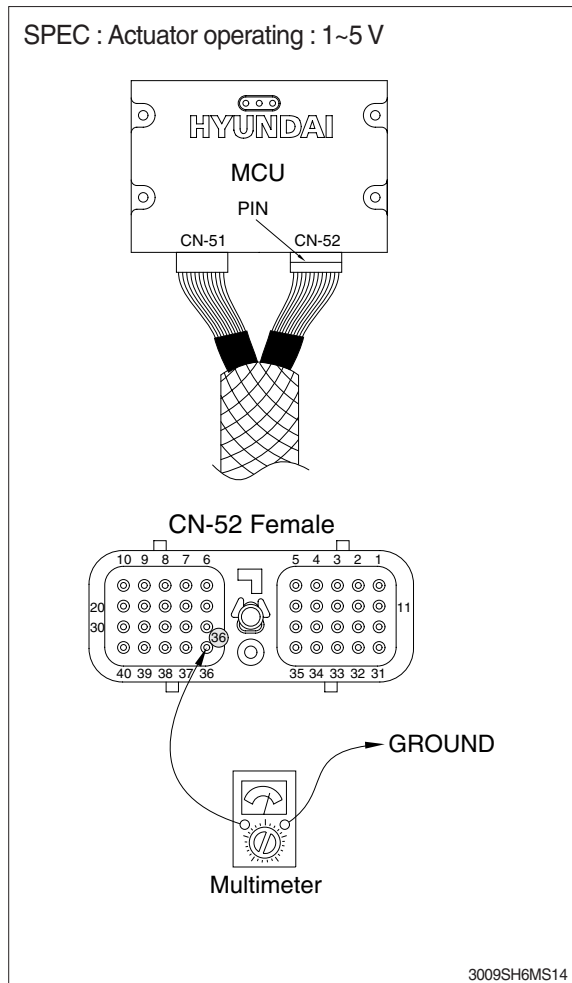

## 10. MALFUNCTION OF BOOM UP PRESSURE SENSOR

· Fault code : HCESPN 127, FMI 0~4

※ Before carrying out below procedure, check all the related connectors are properly inserted.

### 1) INSPECTION PROCEDURE

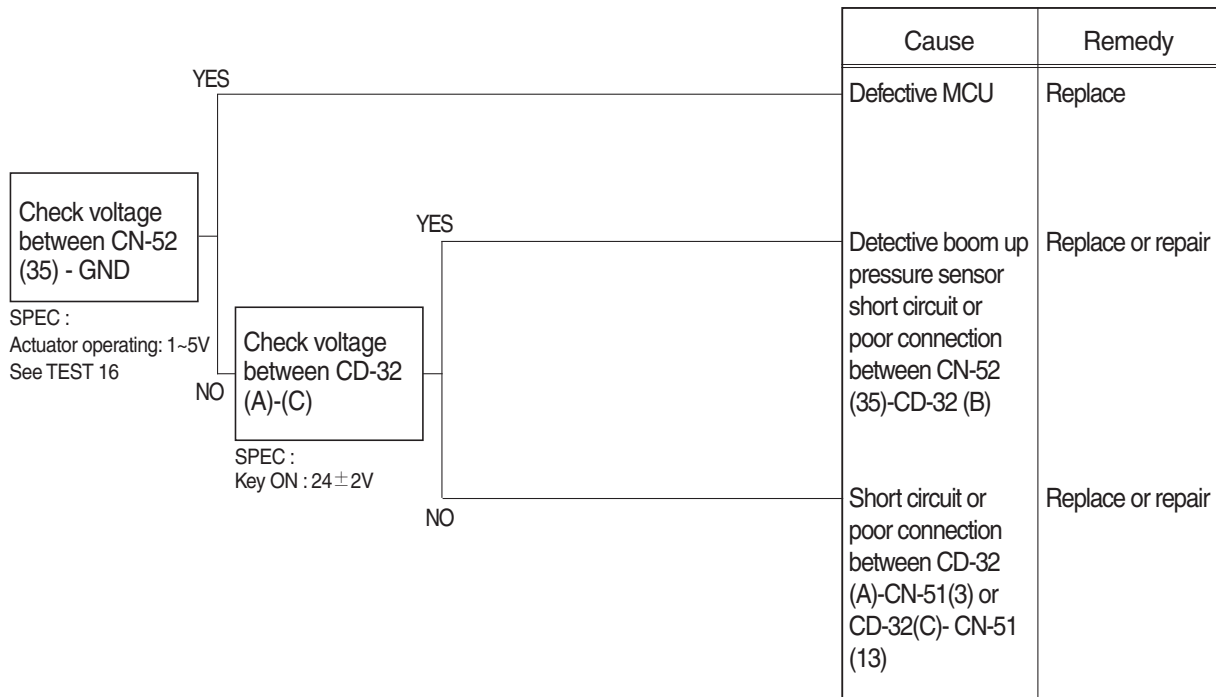

### Wiring diagram

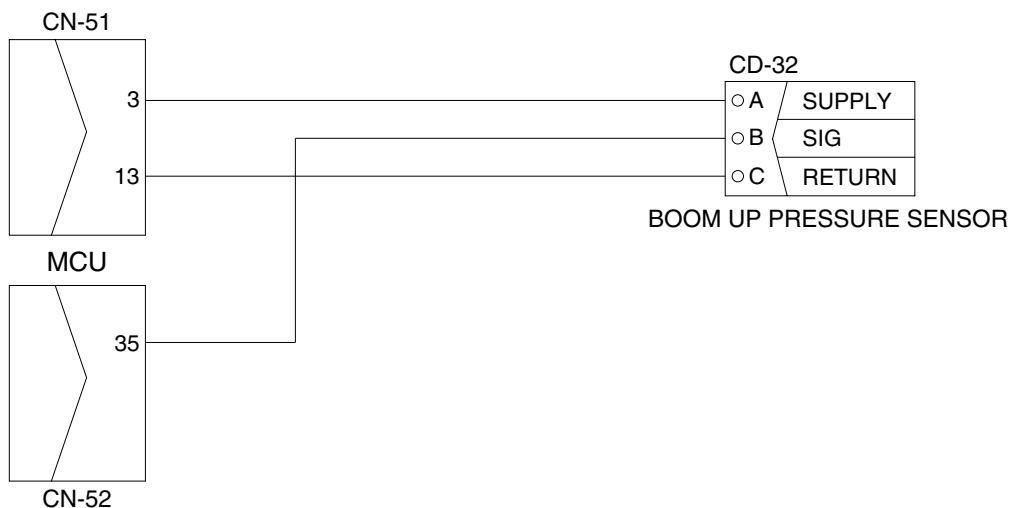

3009SH6MS15

## 2) TEST PROCEDURE

(1) **Test 16** : Check voltage at CN-52(35) and ground.

- ① Prepare 1 piece of thin sharp pin, steel or copper.
- ② Insert prepared pin to rear side of connectors : One pin to (35) of CN-52.
- ③ Starting key ON.
- ④ Check voltage as figure.

SPEC : Actuator operating : 1~5 V

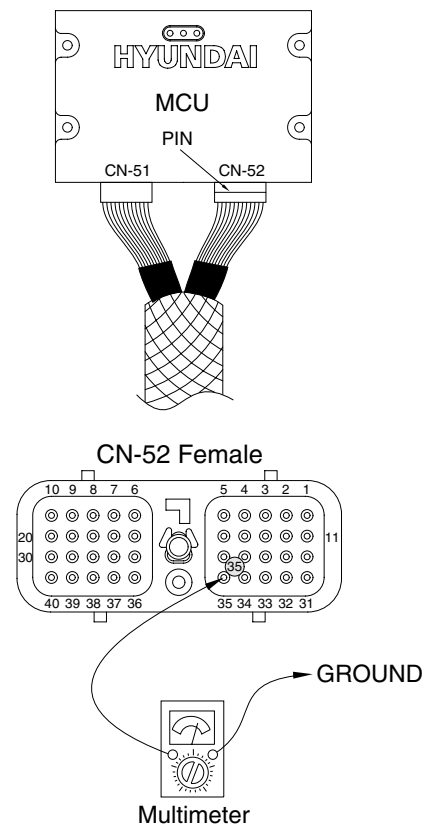

3009SH6MS16

## 11. MALFUNCTION OF POWER MAX

· Fault code : HCESPN 166, FMI 4 or 6

※ Before carrying out below procedure, check all the related connectors are properly inserted.

### 1) INSPECTION PROCEDURE

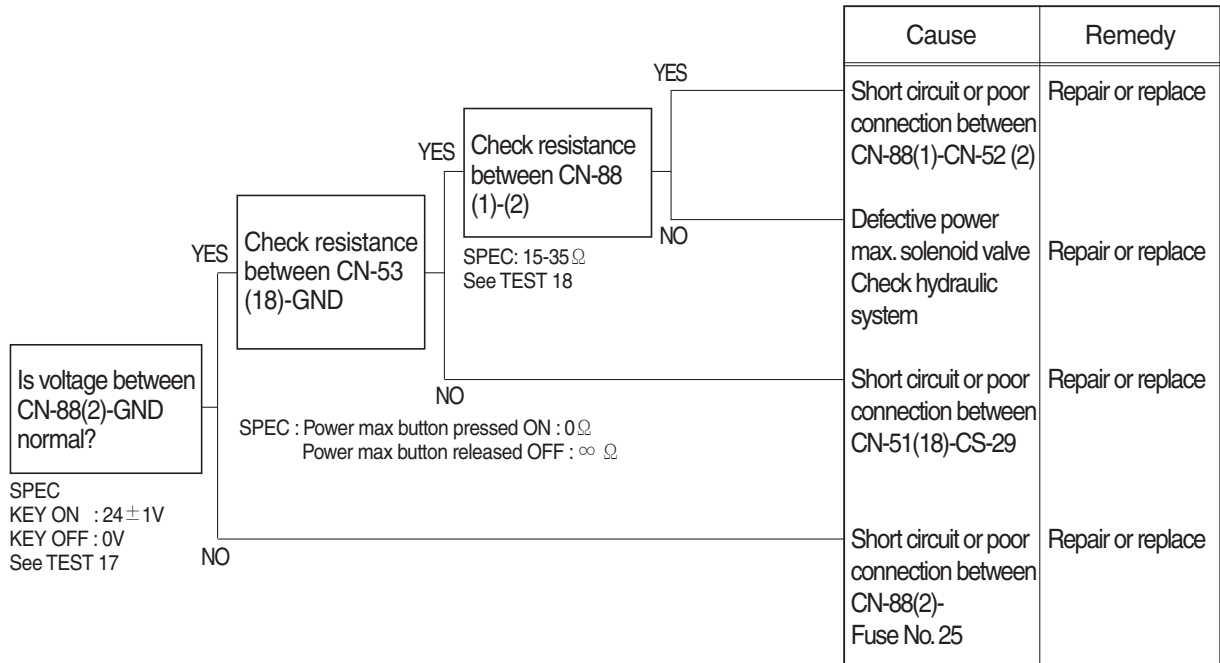

### Wiring diagram

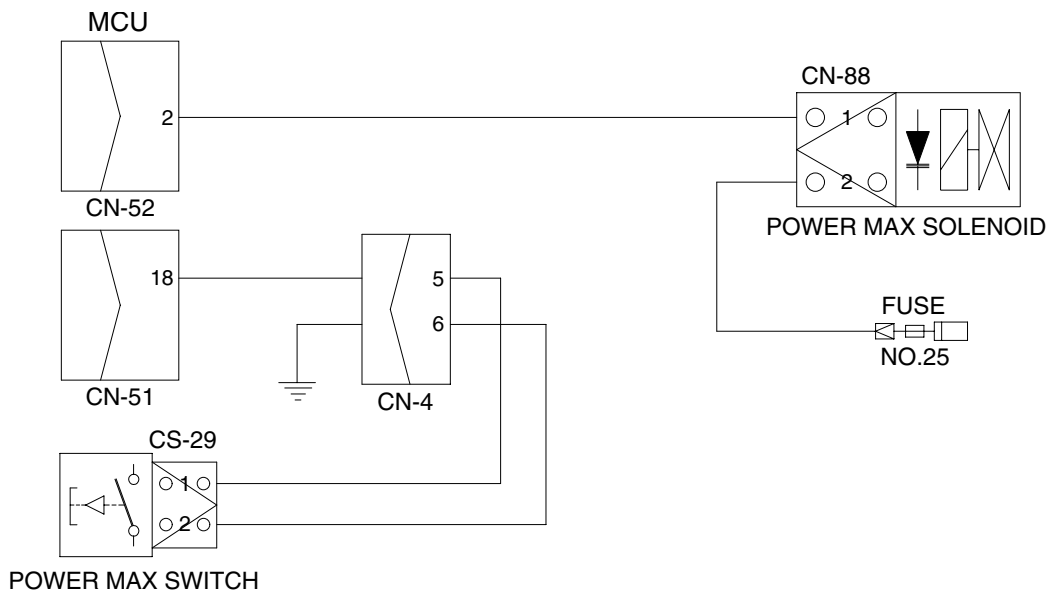

3009SH6MS17

## 2) TEST PROCEDURE

(1) **Test 17:** Check voltage between connector CN-88(2) - GND.

- ① Disconnect connector CN-88 from power max solenoid valve.
- ② Start key ON.
- ③ Check voltage as figure.

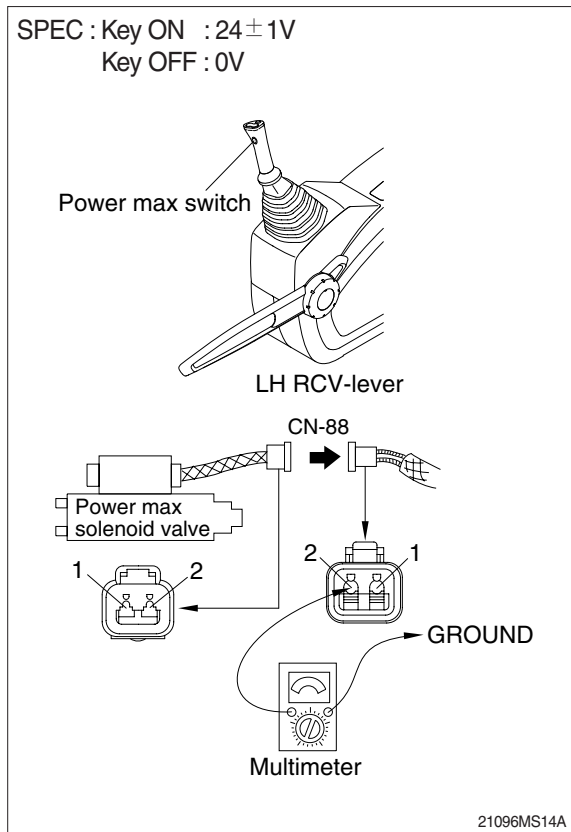

(2) **Test 18:** Check resistance of the solenoid valve between CN-88(1)-(2).

- ① Starting key OFF.
- ② Disconnect connector CN-88 from power max solenoid valve.
- ③ Check resistance as figure.

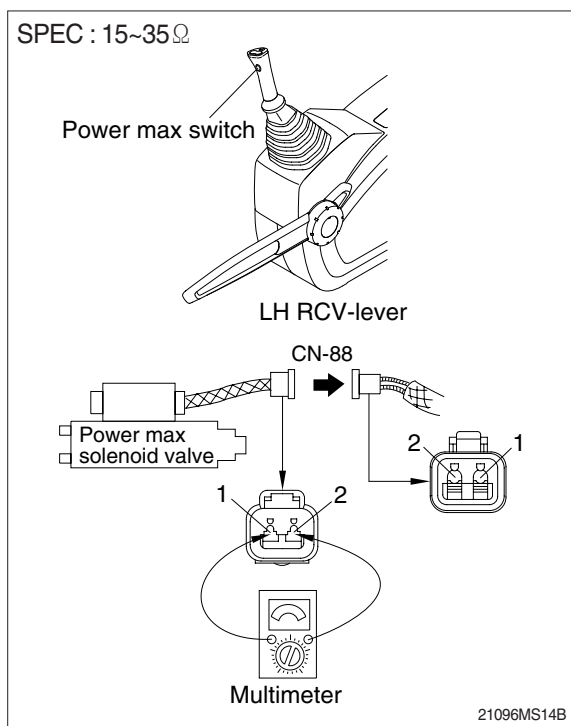

## 12. MALFUNCTION OF BOOM PRIORITY EPPR VALVE

· Fault code : HCESPN 141, FMI 5 or 6

※ Before carrying out below procedure, check all the related connectors are properly inserted.

### 1) INSPECTION PROCEDURE

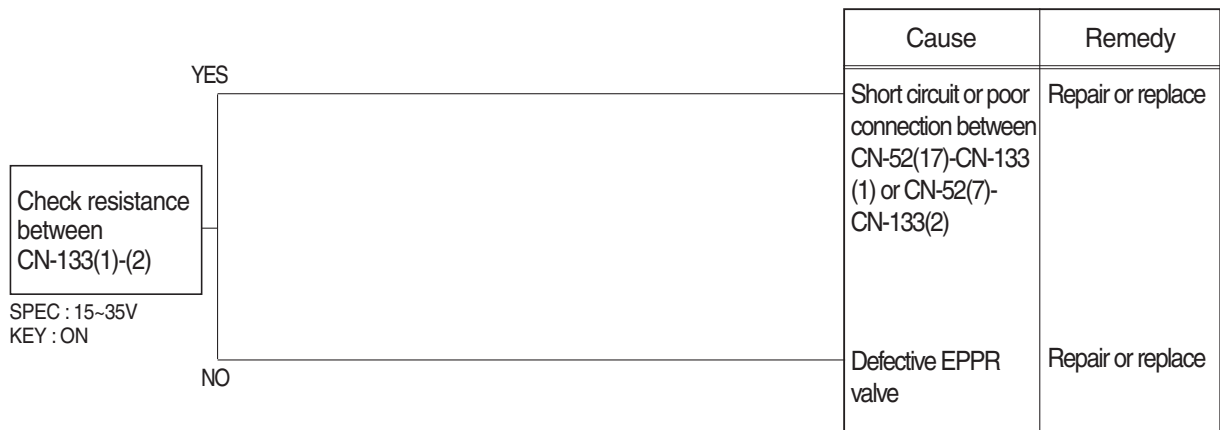

### Wiring diagram

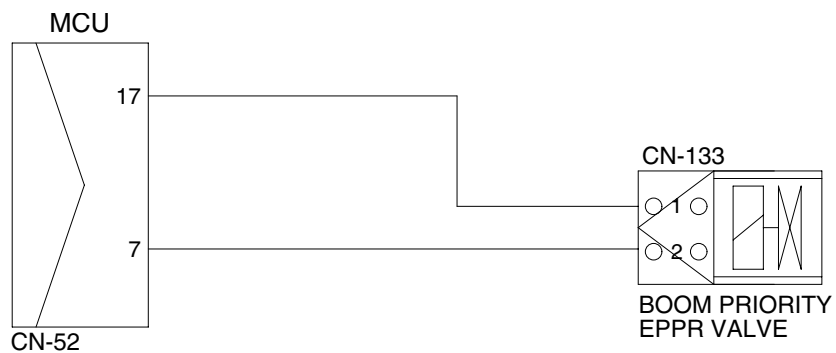

3009SH6MS18

### 13. MALFUNCTION OF ARM REGENERATION SOLENOID

· Fault code : HCESPN 170, FMI 4 or 6

※ Before carrying out below procedure, check all the related connectors are properly inserted.

#### 1) INSPECTION PROCEDURE

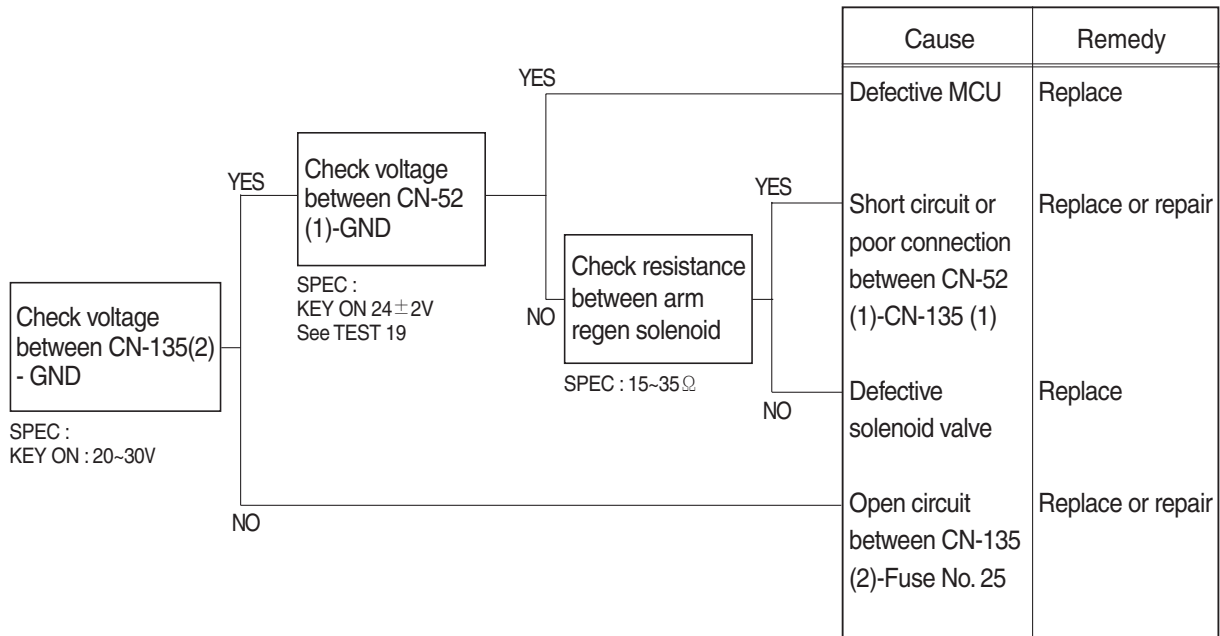

#### Wiring diagram

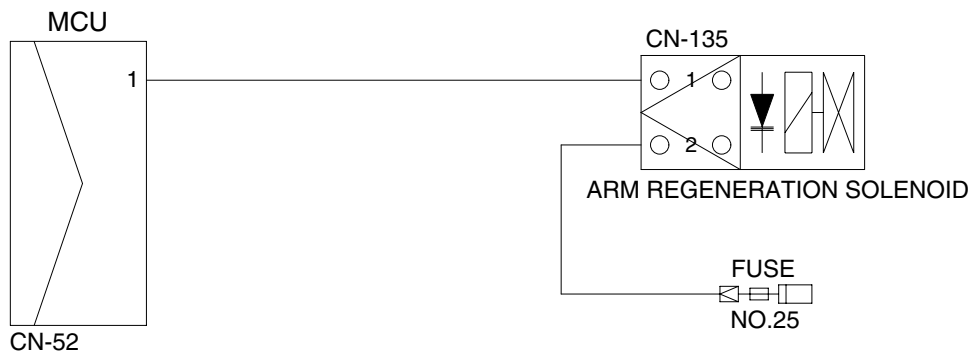

3009SH6MS19

## 2) TEST PROCEDURE

(1) **Test 19** : Check voltage at CN-52(1) and ground.

- ① Prepare 1 piece of thin sharp pin, steel or copper.
- ② Insert prepared pin to rear side of connectors : One pin to (1) of CN-52.
- ③ Starting key ON.
- ④ Check voltage as figure.

SPEC : Key ON :  $24 \pm 2$  V

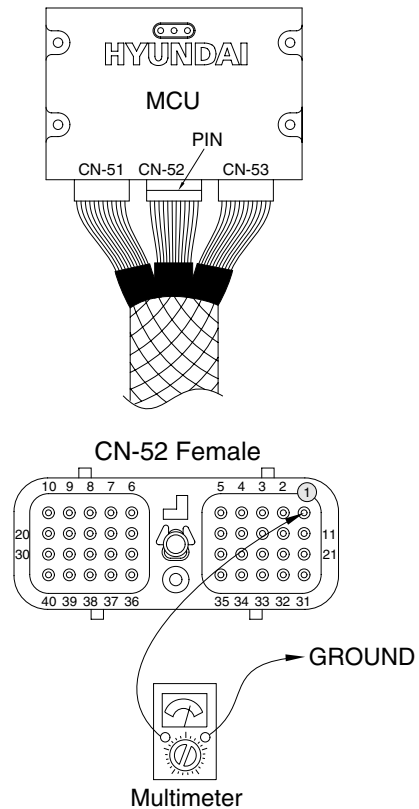

21096MS16A



## MECHATRONICS SYSTEM (CLUSTER TYPE 2)

### 1. ALL ACTUATORS SPEED ARE SLOW

- ※ Boom, Arm, Bucket, Swing and travel speed are slow, but engine speed is good.
- ※ Spec : P-mode 2100 ± 50 rpm    S-mode 2000 ± 50 rpm    E-mode 1900 ± 50 rpm
- ※ Before carrying out below procedure, check all the related connectors are properly inserted and fault code on the cluster.

#### 1) INSPECTION PROCEDURE

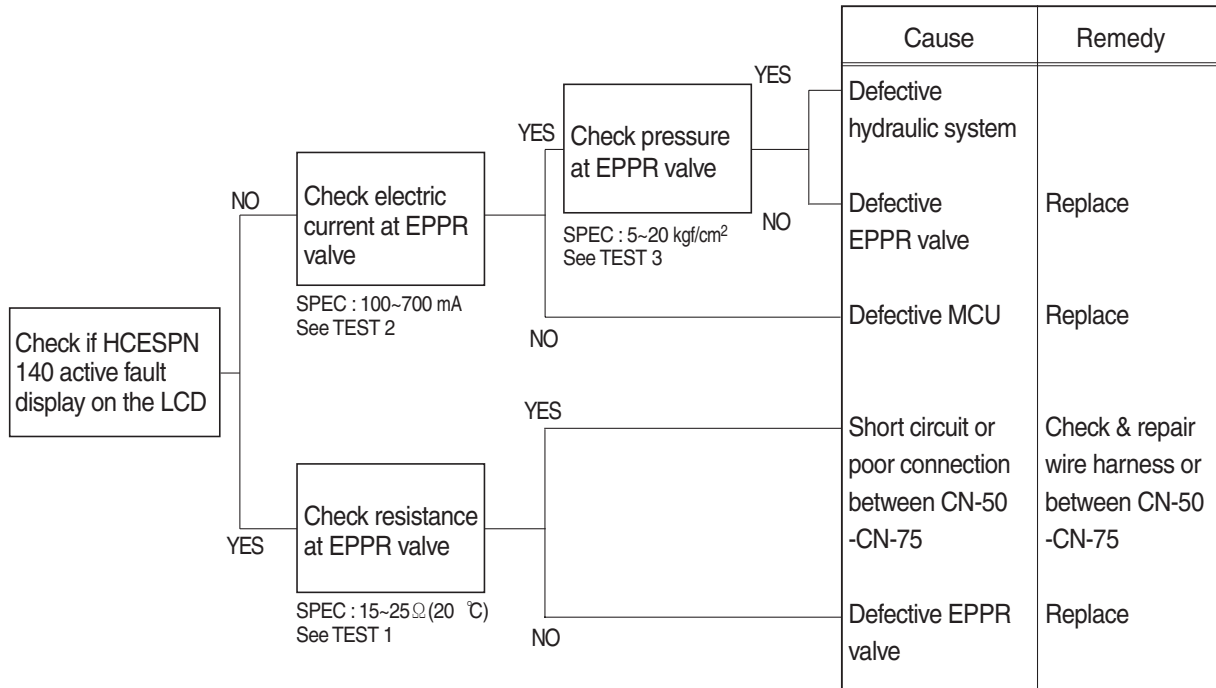

#### Wiring diagram

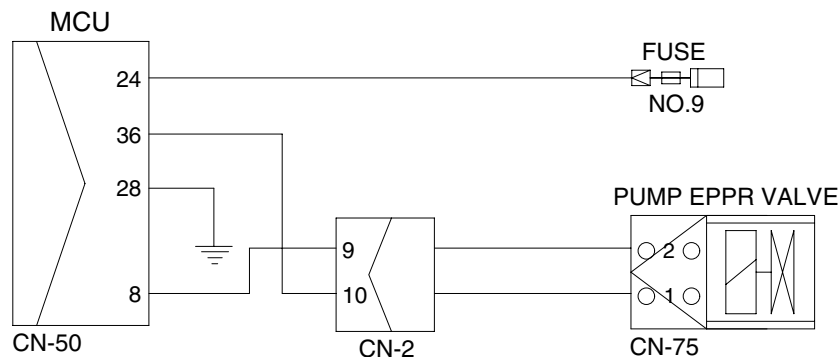

## 2) TEST PROCEDURE

(1) **Test 1** : Check resistance at connector CN-75.

- ① Starting key OFF.
- ② Disconnect connector CN-75 from EPPR valve at main hydraulic pump.
- ③ Check resistance between 2 lines as figure.

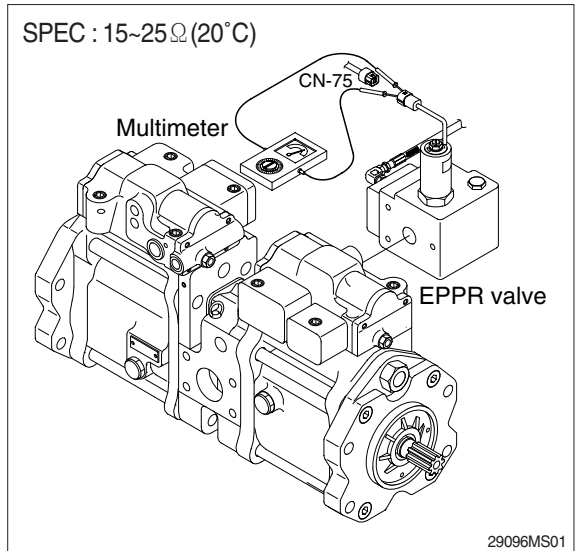

(2) **Test 2** : Check electric current at EPPR valve.

- ① Install multimeter as figure.
- ② Start engine.
- ③ Set the accel dial at "10" (MAX)
- ④ Set H-mode and cancel auto decel mode.
- ⑤ If tachometer show approx  $2000 \pm 50$  rpm, check electric current.

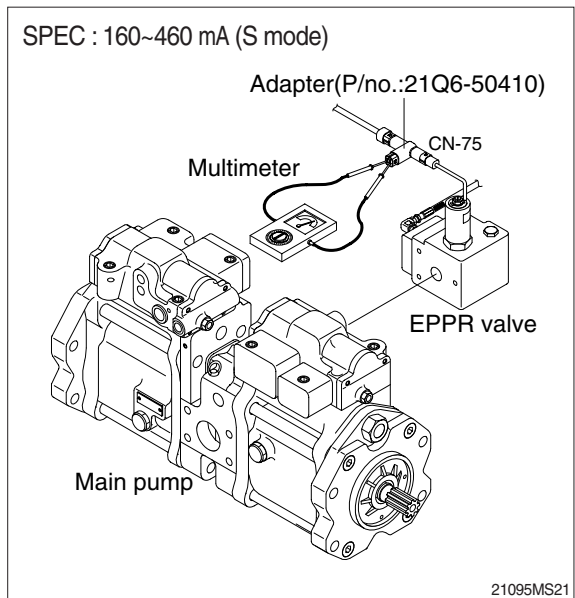

(3) **Test 3** : Check pressure at EPPR valve.

- ① Remove plug and connect pressure gauge as figure.
  - Gauge capacity : 0 to 50 kgf/cm<sup>2</sup>  
(0 to 710 psi)
- ② Start engine.
- ③ Set the accel dial at "10" (Max).
- ④ Set H-mode and cancel auto decel mode.
- ⑤ If tachometer show approx  $2000 \pm 50$  rpm, check pressure.
- ⑥ If pressure is not correct, adjust it.
- ⑦ After adjust, test the machine.

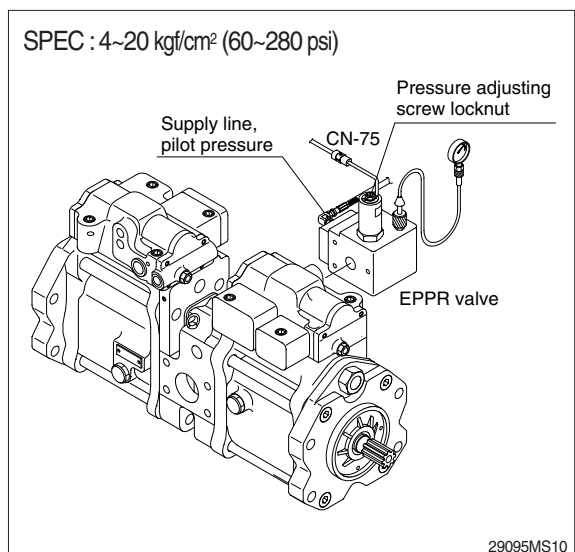

## 2. ENGINE STALL

※ Before carrying out below procedure, check all the related connectors are properly inserted.

### 1) INSPECTION PROCEDURE

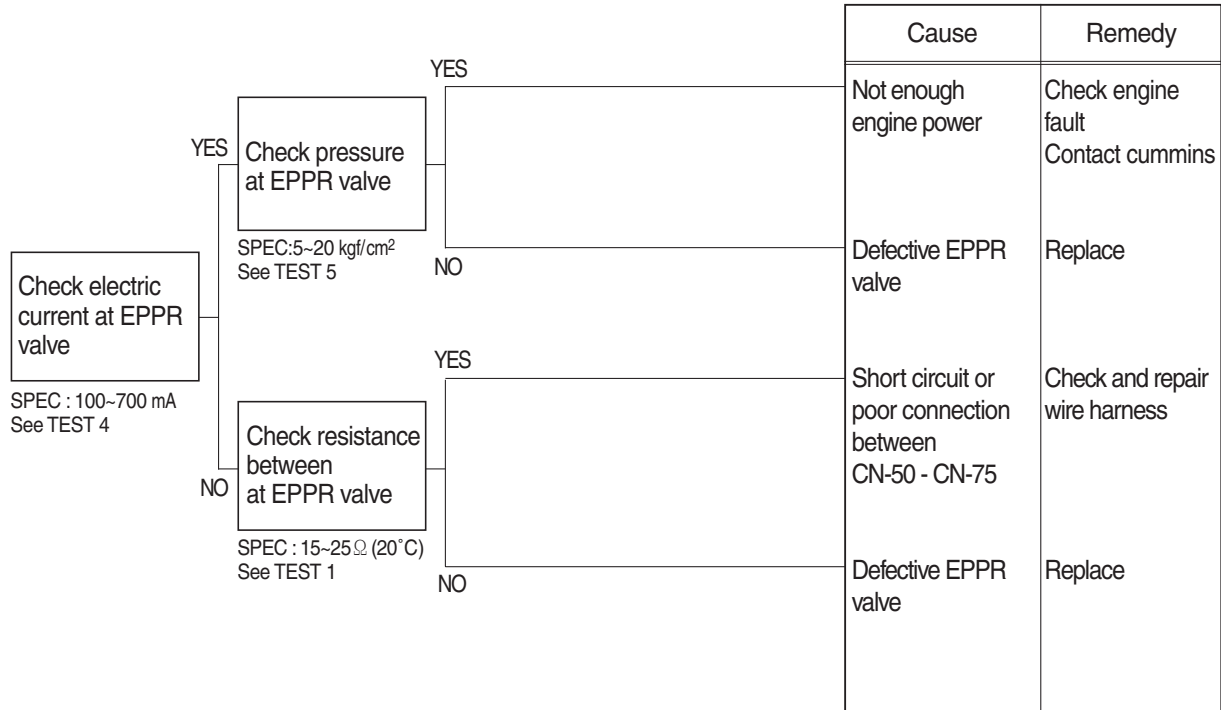

### Wiring diagram

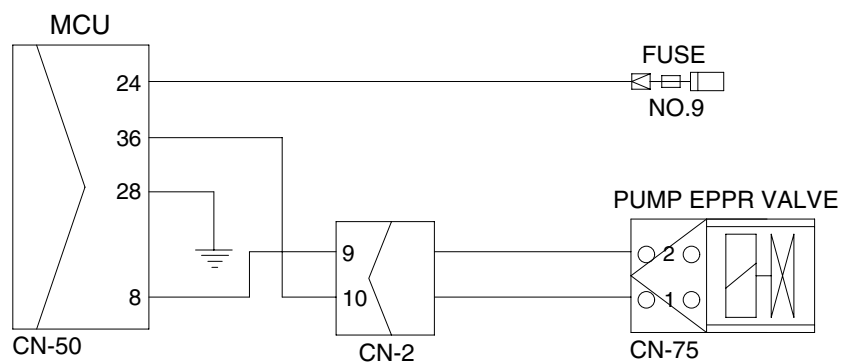

3009SH6MS30

## 2) TEST PROCEDURE

### (1) Test 4 : Check electric current at EPPR valve at S-mode

- ① Install multimeter as figure.
- ② Start engine.
- ③ Set the accel dial at "10" (max)
- ④ Set H-mode with  $2000 \pm 50$  rpm.
- ⑤ Check electric current.

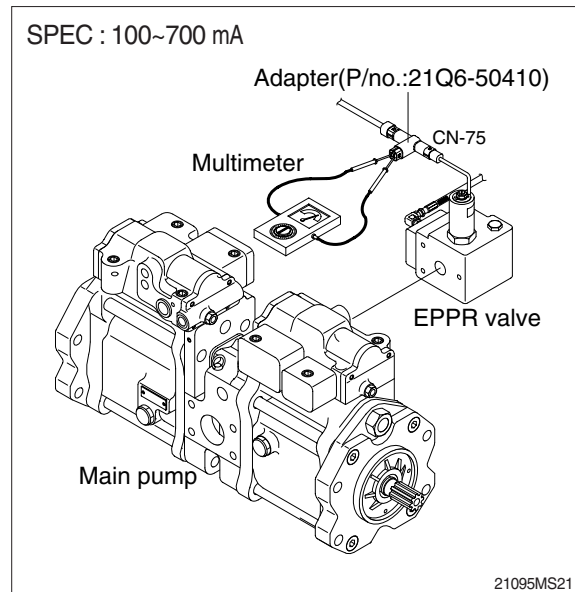

### (2) Test 5 : Check pressure at EPPR valve at S-mode

- ① Connect pressure gauge at EPPR valve.
- ② Start engine.
- ③ Set the accel dial at "10" (max)
- ④ Set H-mode with  $2000 \pm 50$  rpm.
- ⑤ Operate bucket lever completely push or pull.
- ⑥ Hold arm lever at the end of stroke.
- ⑦ Check pressure at relief position.

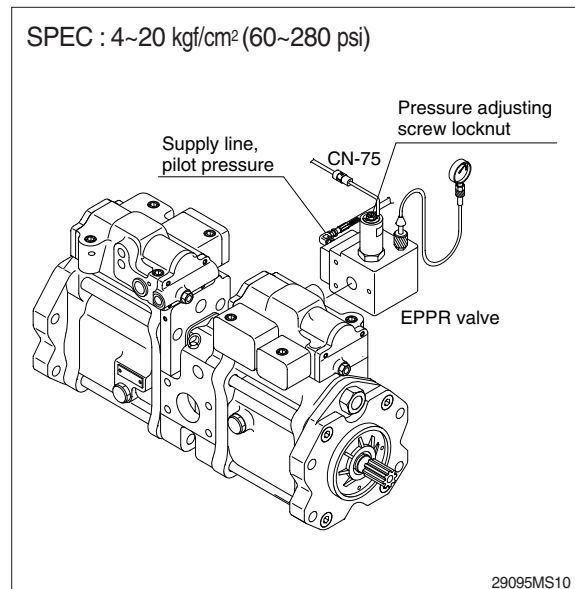

### 3. MALFUNCTION OF CLUSTER OR MODE SELECTION SYSTEM

※ Before carrying out below procedure, check all the related connectors are properly inserted.

#### 1) INSPECTION PROCEDURE

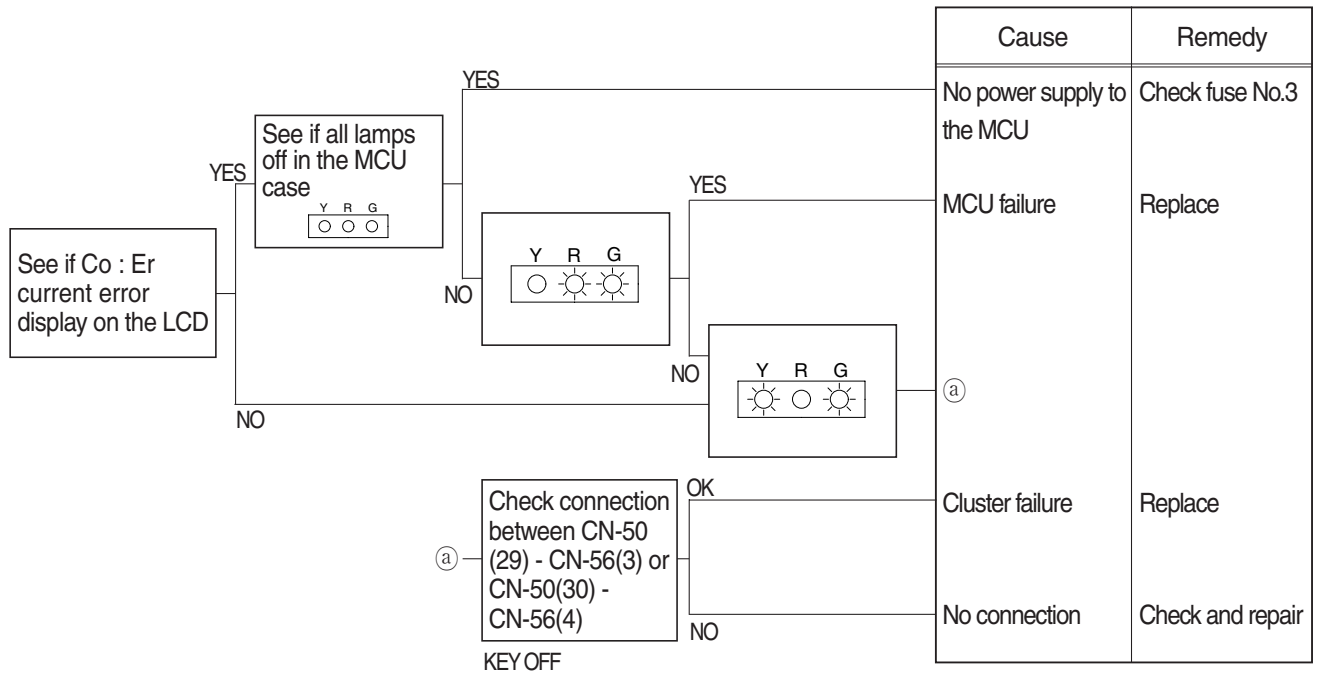

#### Wiring diagram

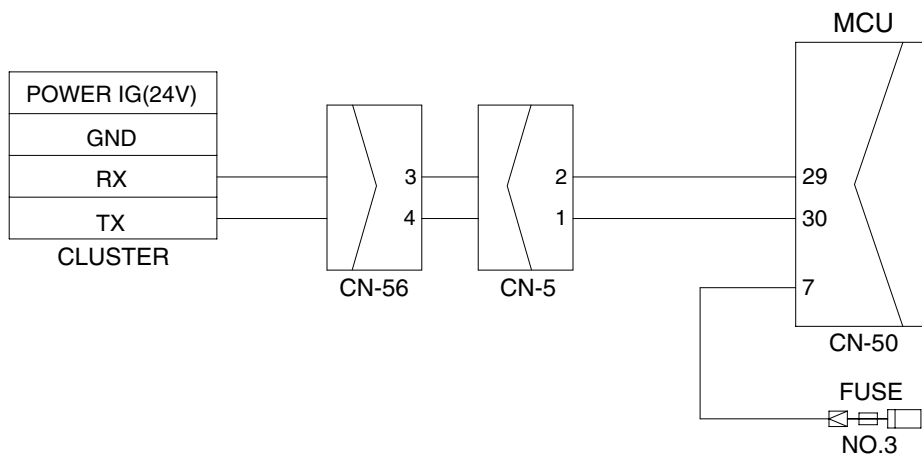

3009SH6MS31

#### 4. MALFUNCTION OF ACCEL DIAL

※ Before carrying out below procedure, check all the related connectors are properly inserted.

##### 1) INSPECTION PROCEDURE

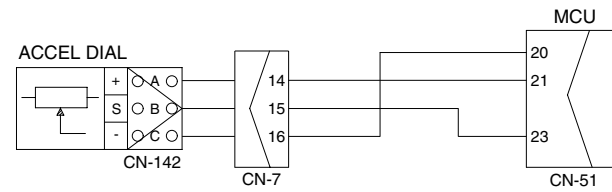
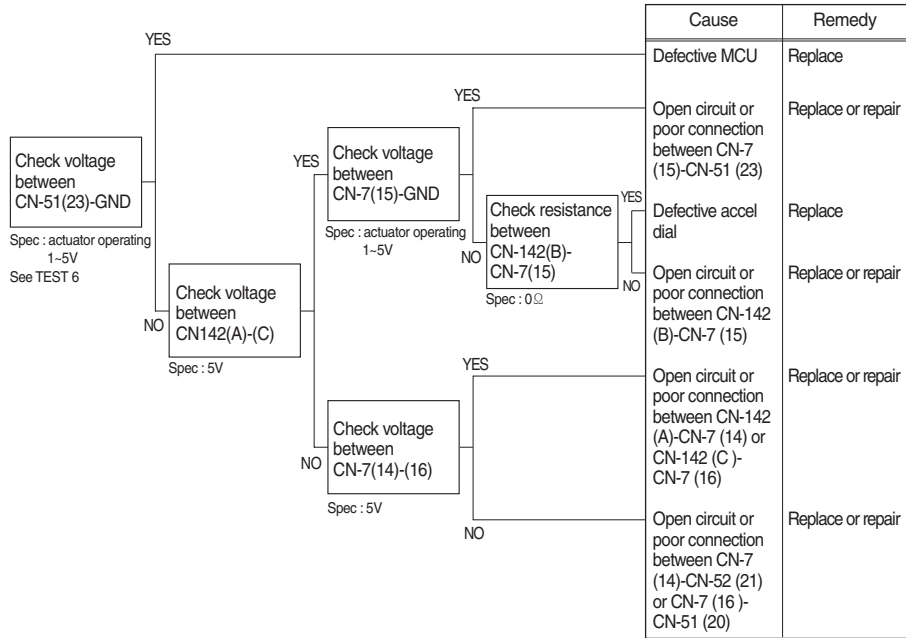

## 2) TEST PROCEDURE

(1) **Test 6** : Check voltage at CN-51(23) and ground.

- ① Prepare 1 piece of thin sharp pin, steel or copper.
- ② Insert prepared pin to rear side of connectors : One pin to (21) of CN-52.
- ③ Starting key ON.
- ④ Check voltage as figure.

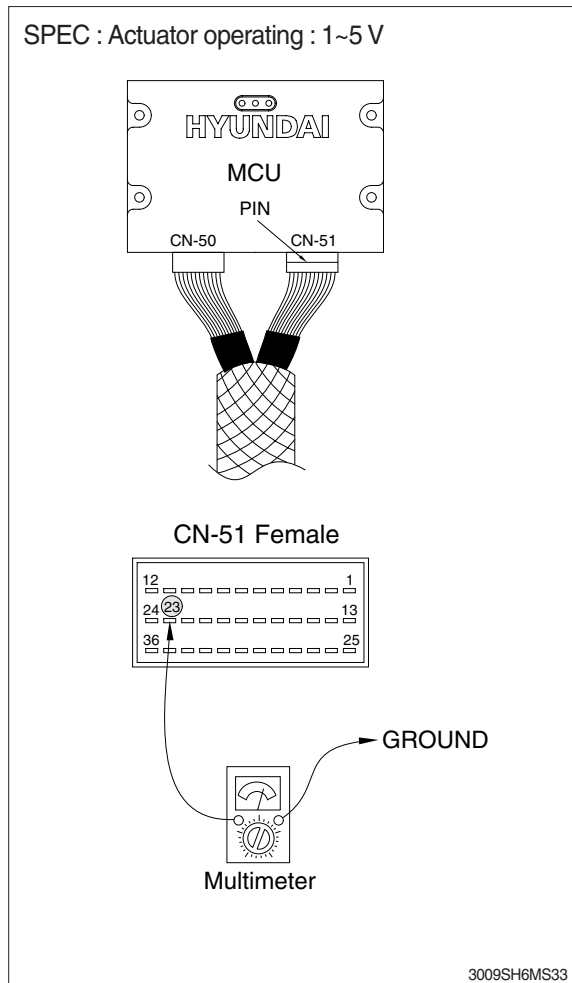

## 5. AUTO DECEL SYSTEM DOES NOT WORK

※ Before carrying out below procedure, check all the related connectors are properly inserted.

### 1) INSPECTION PROCEDURE

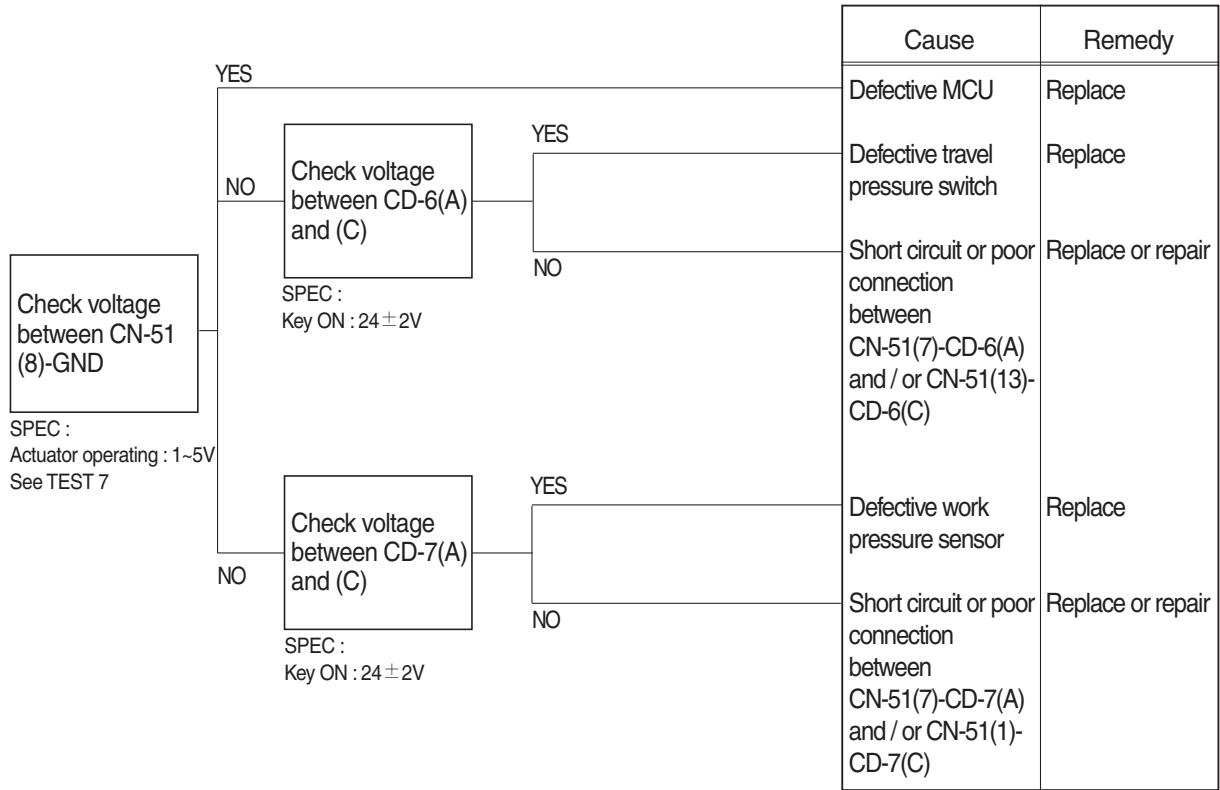

### Wiring diagram

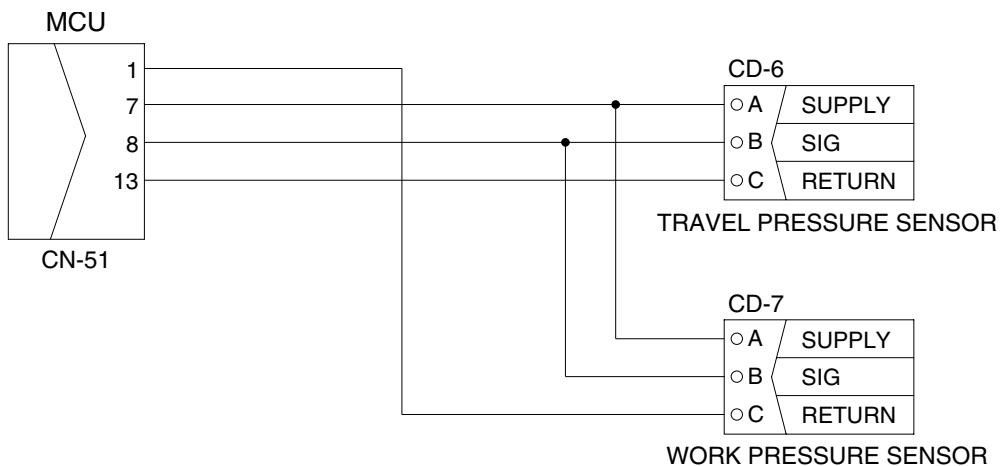

3009SH6MS34



## 2) TEST PROCEDURE

(1) **Test 7** : Check voltage at CN-51(8) and ground.

- ① Prepare 1 piece of thin sharp pin, steel or copper.
- ② Insert prepared pin to rear side of connectors : One pin to (8) of CN-51.
- ③ Starting key ON.
- ④ Check voltage as figure.

SPEC : Actuator operating : 1~5 V

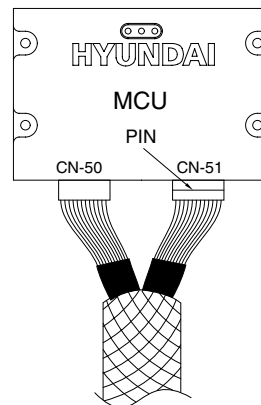

CN-51 Female

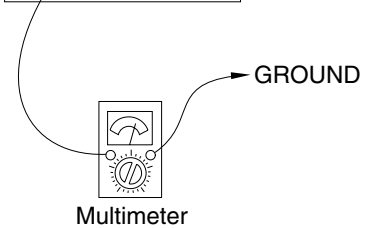
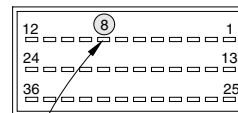

3009SH6MS35

## 6. MALFUNCTION OF PUMP 1 PRESSURE SENSOR

※ Before carrying out below procedure, check all the related connectors are properly inserted.

### 1) INSPECTION PROCEDURE

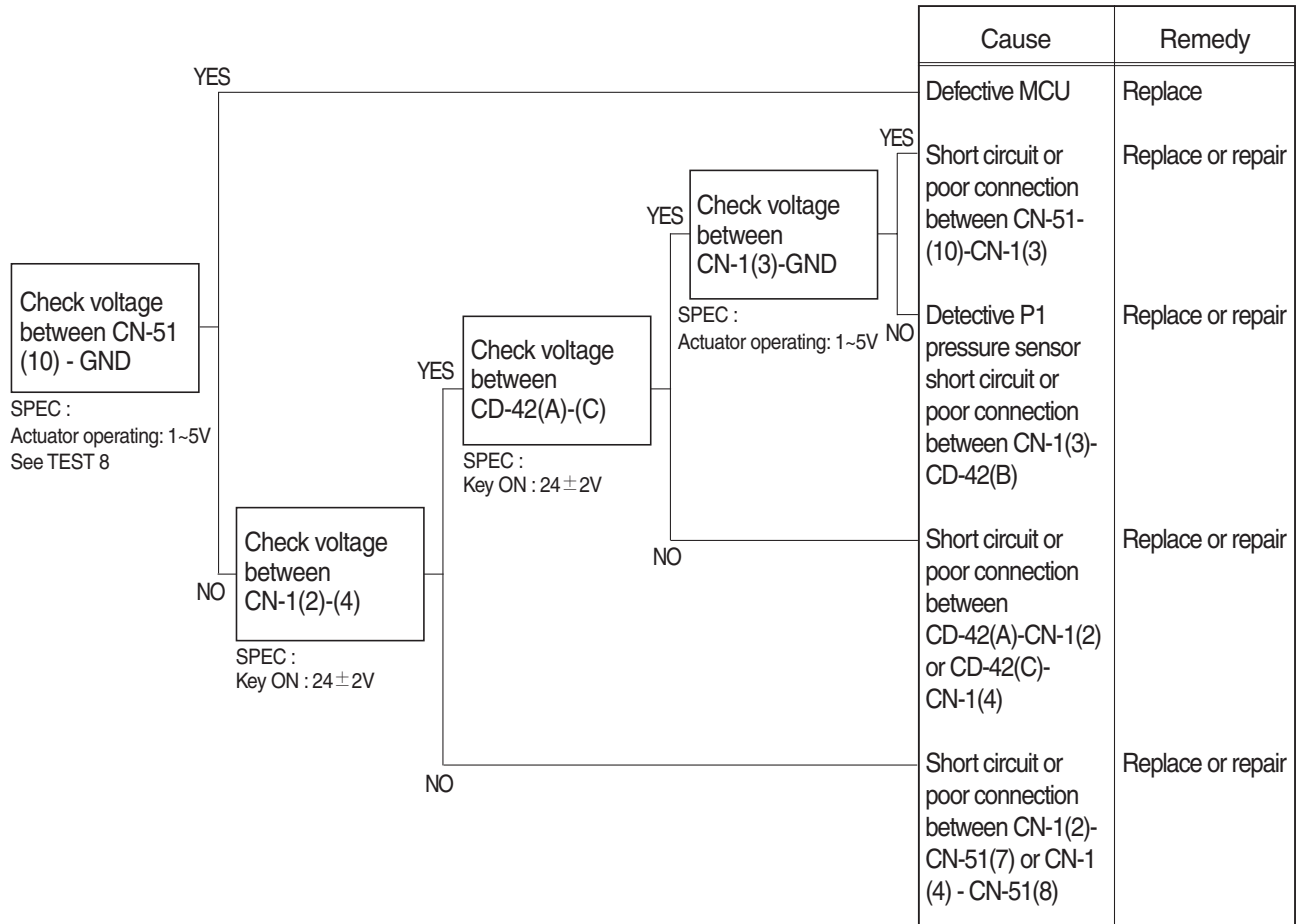

### Wiring diagram

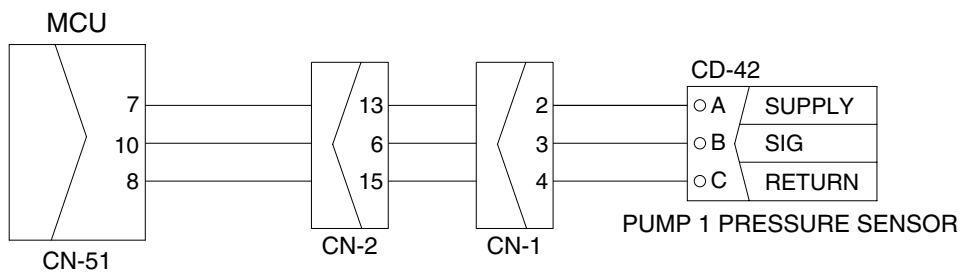

## 2) TEST PROCEDURE

(1) **Test 8** : Check voltage at CN-51(10) and ground.

- ① Prepare 1 piece of thin sharp pin, steel or copper.
- ② Insert prepared pin to rear side of connectors : One pin to (10) of CN-51.
- ③ Starting key ON.
- ④ Check voltage as figure.

SPEC : Actuator operating : 1~5 V

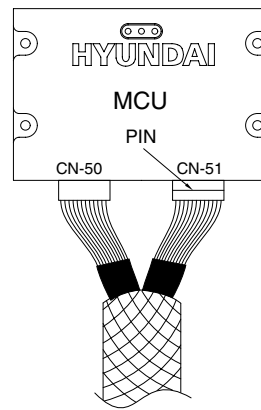

CN-51 Female

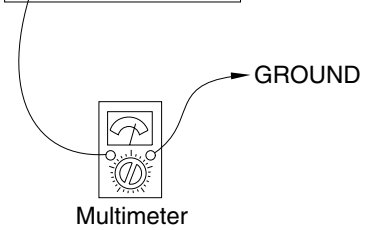
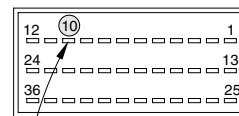

3009SH6MS37

## 7. MALFUNCTION OF PUMP 2 PRESSURE SENSOR

※ Before carrying out below procedure, check all the related connectors are properly inserted.

### 1) INSPECTION PROCEDURE

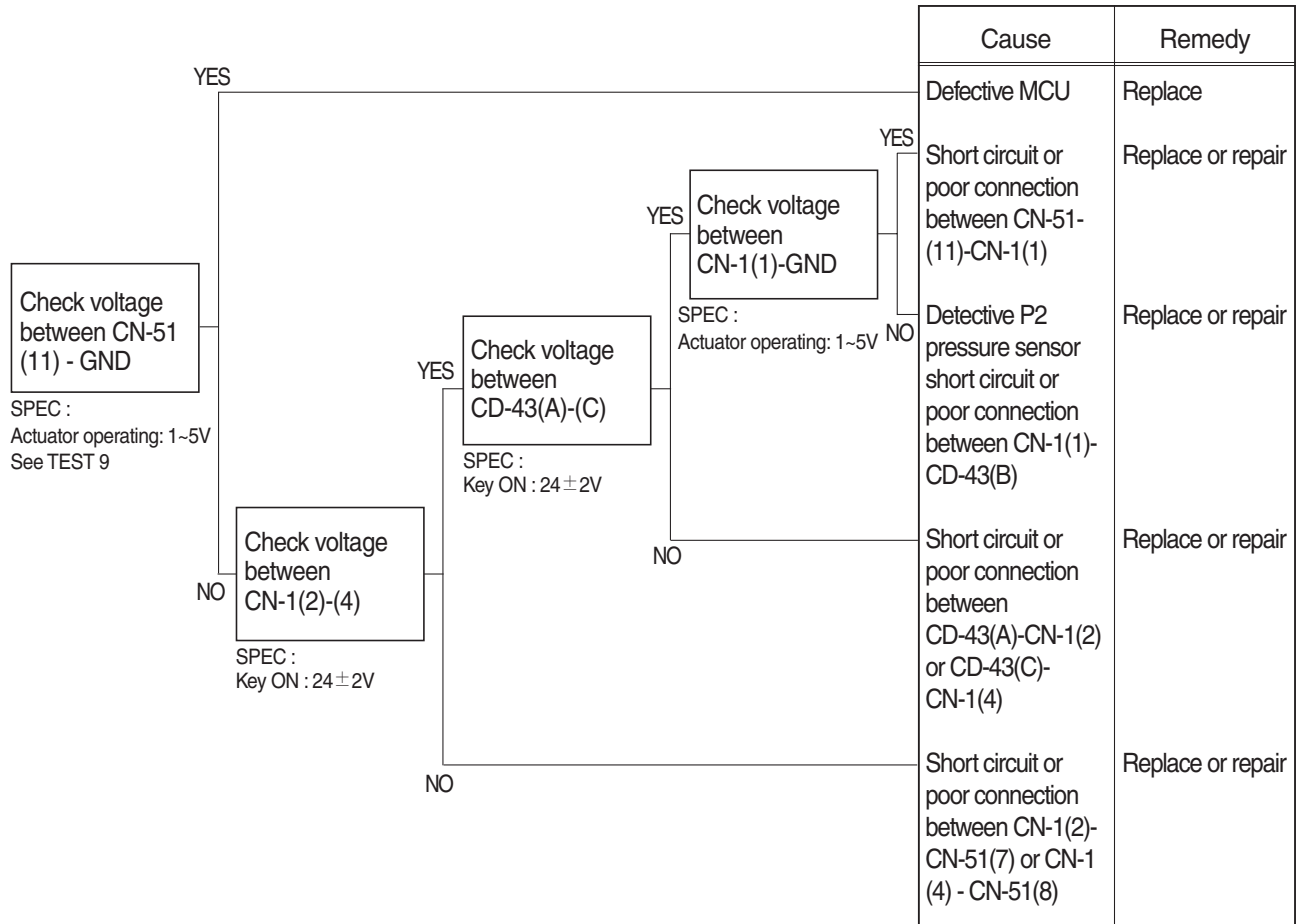

### Wiring diagram

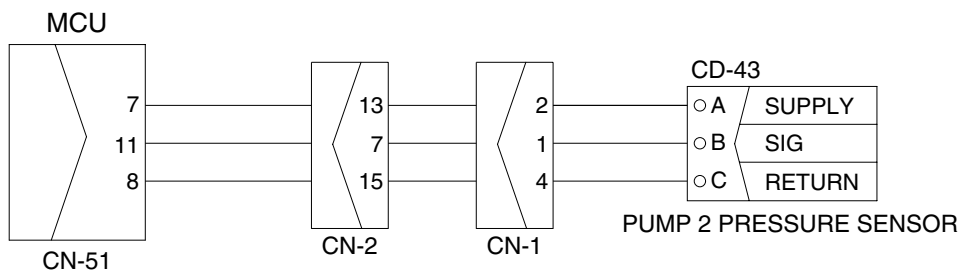

## 2) TEST PROCEDURE

(1) Test 9 : Check voltage at CN-51(11) and ground.

- ① Prepare 1 piece of thin sharp pin, steel or copper.
- ② Insert prepared pin to rear side of connectors : One pin to (11) of CN-51.
- ③ Starting key ON.
- ④ Check voltage as figure.

SPEC : Actuator operating : 1~5 V

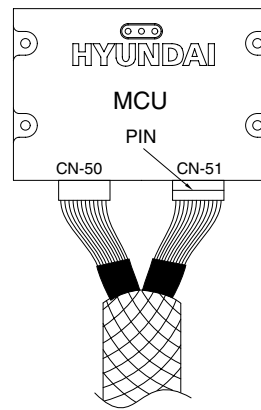

CN-51 Female

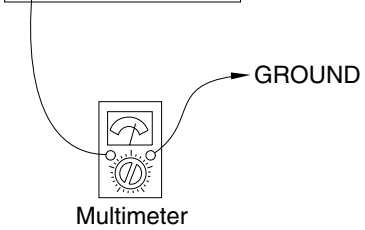
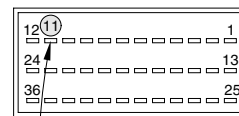

3009SH6MS39

## 8. MALFUNCTION OF PUMP 3 PRESSURE SENSOR

※ Before carrying out below procedure, check all the related connectors are properly inserted.

### 1) INSPECTION PROCEDURE

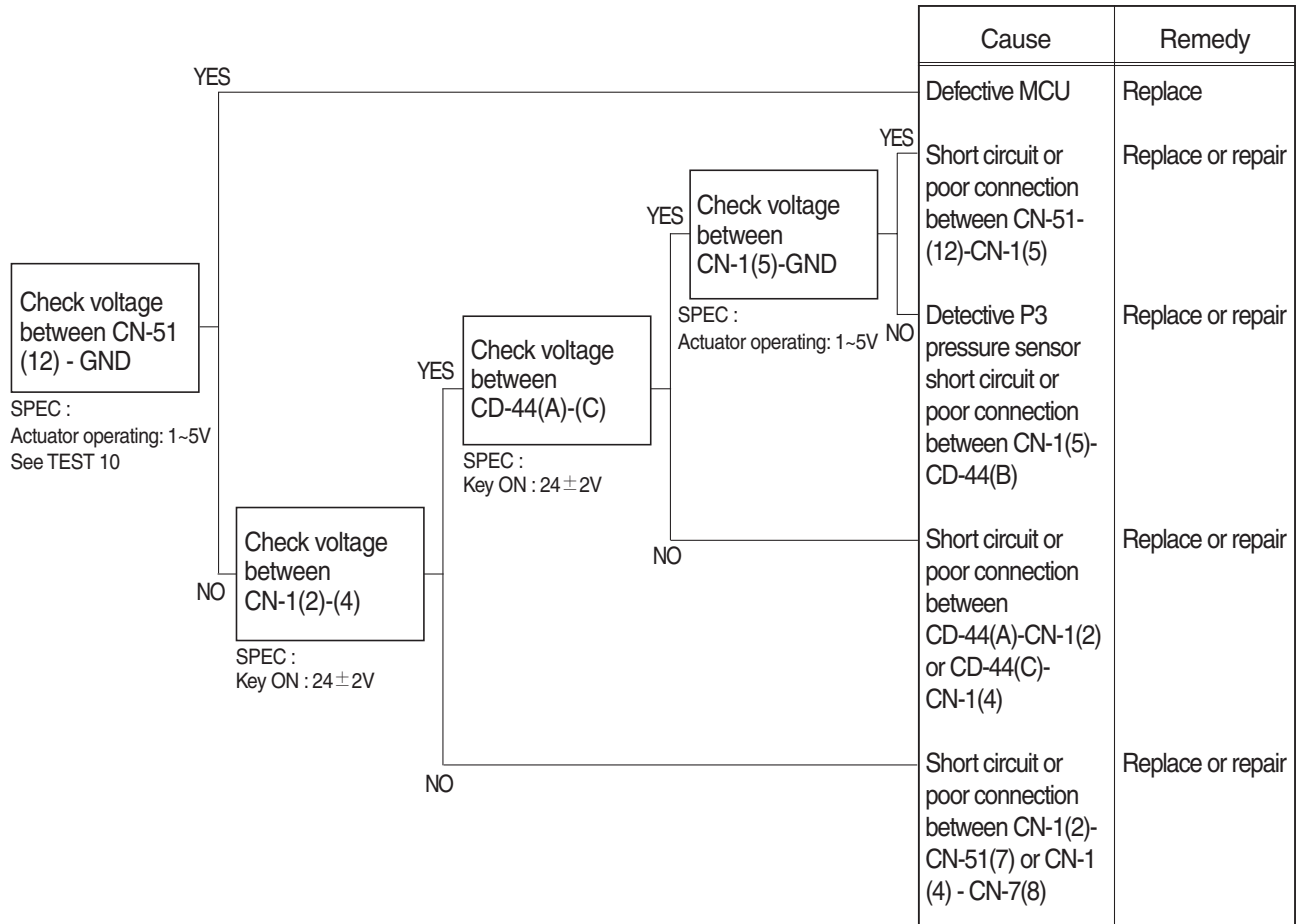

### Wiring diagram

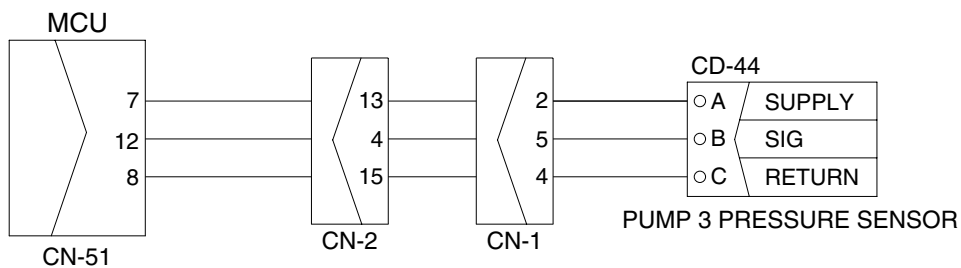

## 2) TEST PROCEDURE

(1) **Test 10** : Check voltage at CN-51(12) and ground.

- ① Prepare 1 piece of thin sharp pin, steel or copper.
- ② Insert prepared pin to rear side of connectors : One pin to (12) of CN-51.
- ③ Starting key ON.
- ④ Check voltage as figure.

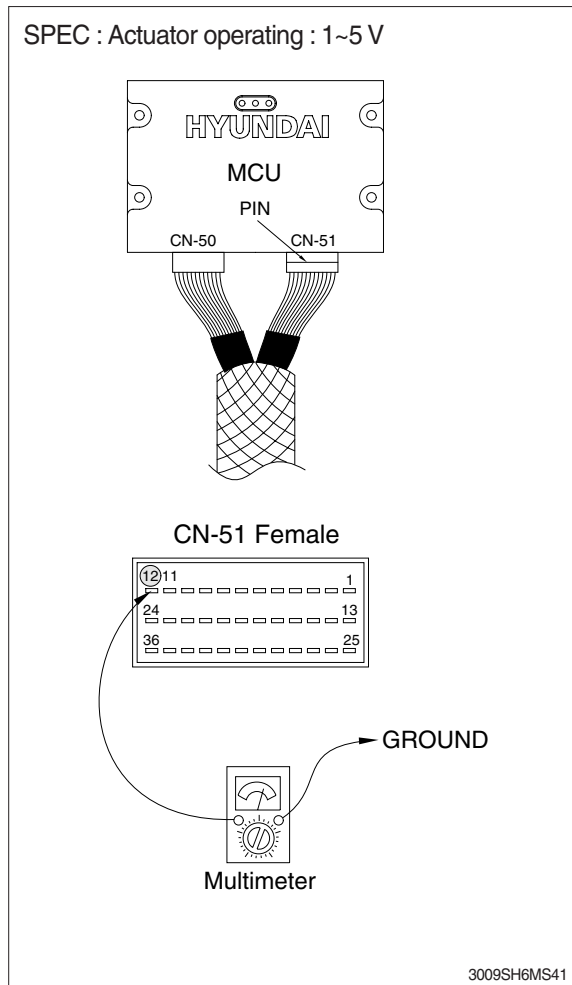

## 9. MALFUNCTION OF POWER MAX

※ Before carrying out below procedure, check all the related connectors are properly inserted.

### 1) INSPECTION PROCEDURE

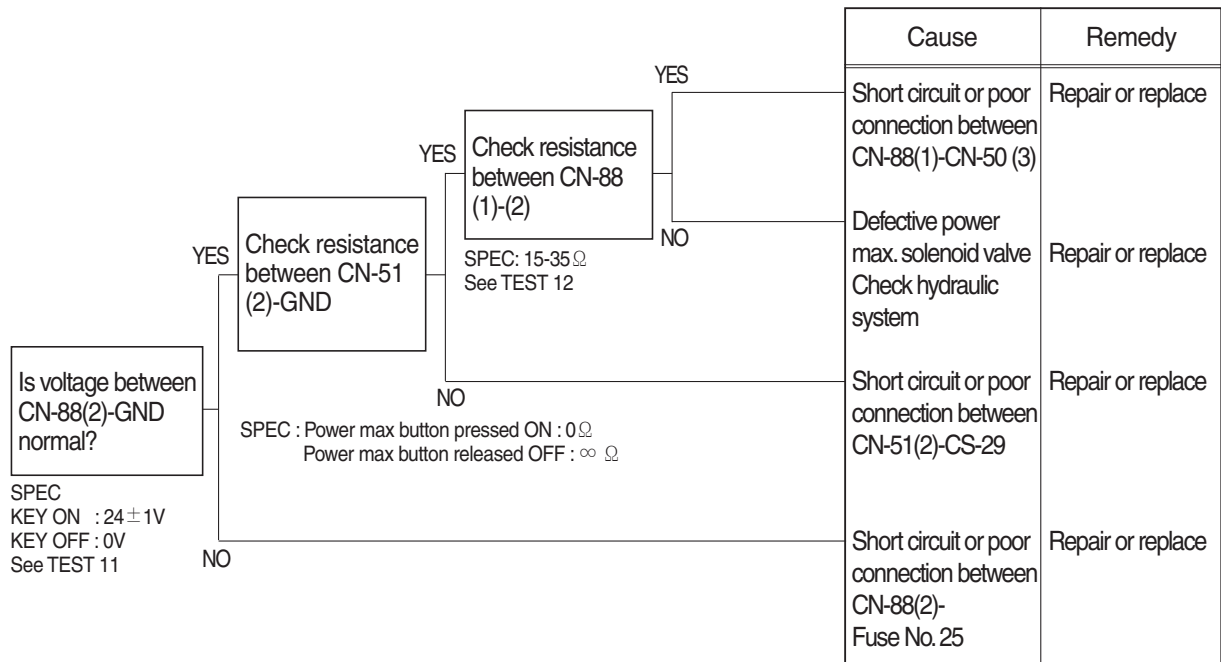

### Wiring diagram

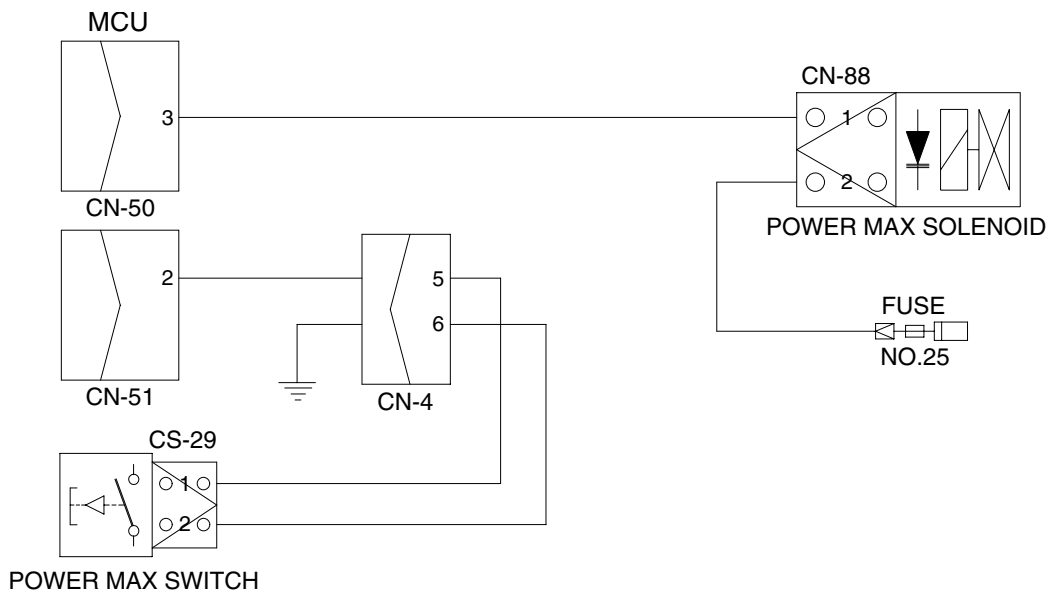

3009SH6MS42



## 2) TEST PROCEDURE

(1) **Test 11:** Check voltage between connector CN-88(2) - GND.

- ① Disconnect connector CN-88 from power max solenoid valve.
- ② Start key ON.
- ③ Check voltage as figure.

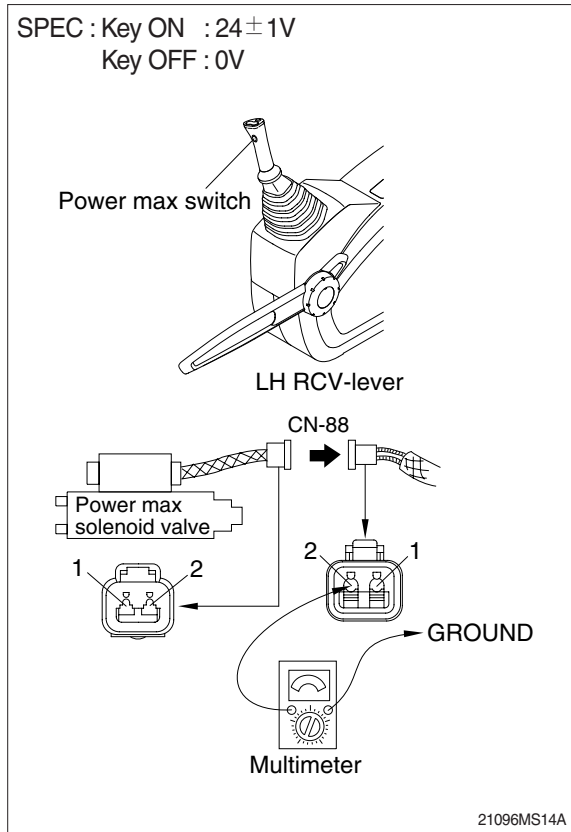

(2) **Test 12:** Check resistance of the solenoid valve between CN-88(1)-(2).

- ① Starting key OFF.
- ② Disconnect connector CN-88 from power max solenoid valve.
- ③ Check resistance as figure.

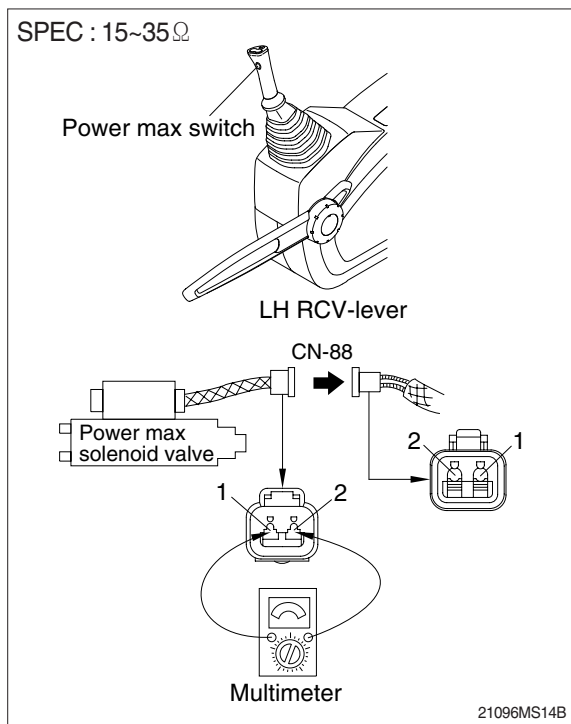

## 10. MALFUNCTION OF BOOM PRIORITY EPPR VALVE

※ Before carrying out below procedure, check all the related connectors are properly inserted.

### 1) INSPECTION PROCEDURE

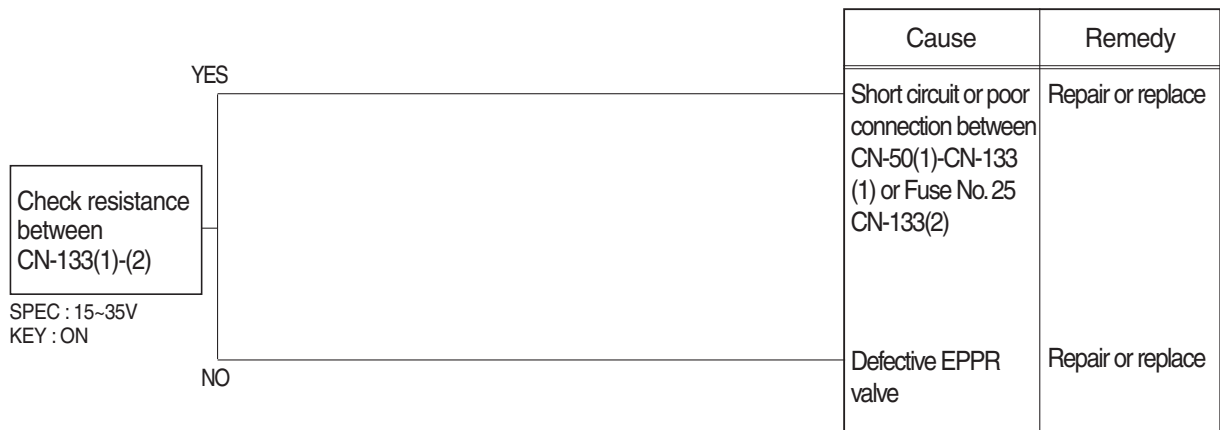

### Wiring diagram

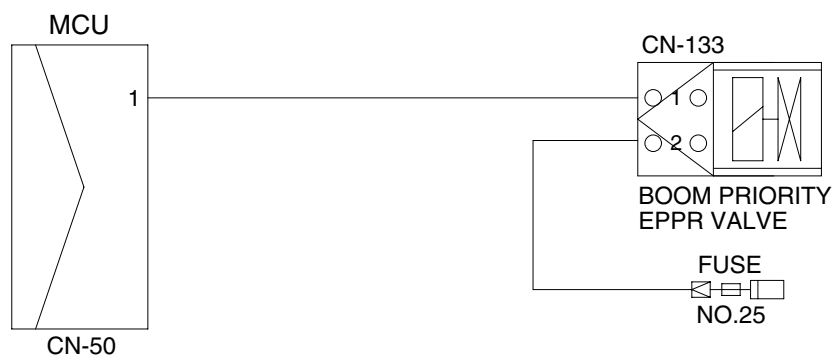

3009SH6MS43