

ELECTRICAL CIRCUIT (2/2, CLUSTER TYPE 1)

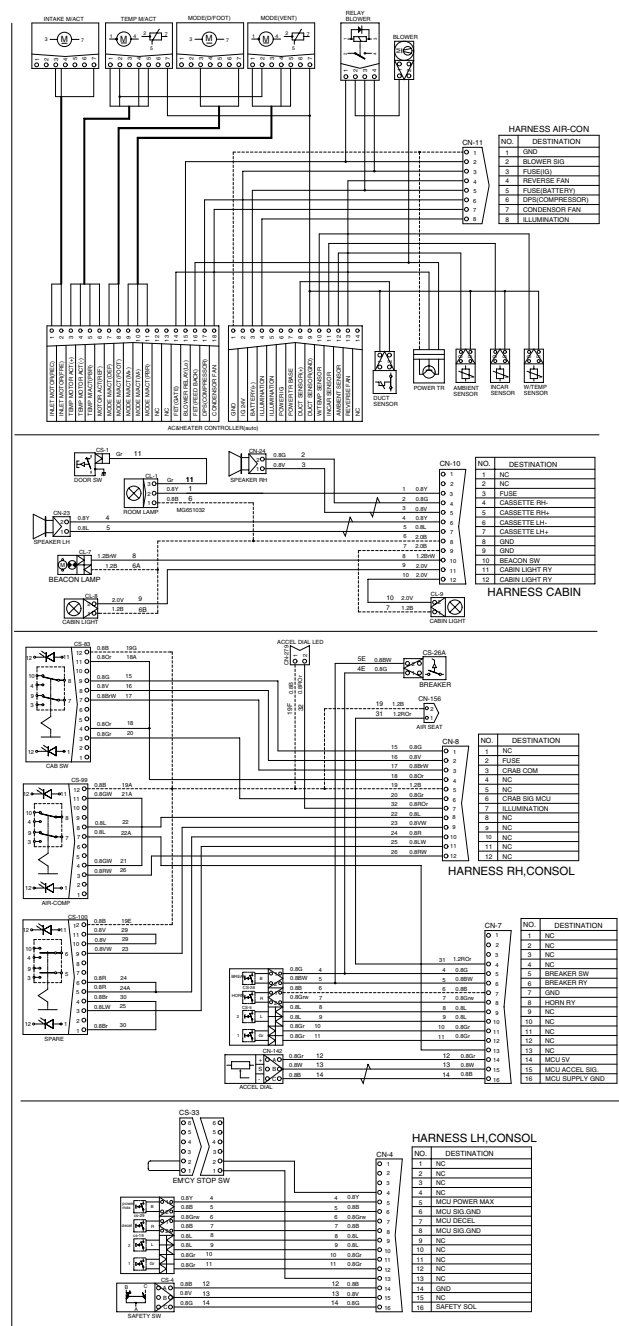

■ ELECTRICAL CIRCUIT (1/2, CLUSTER TYPE 2)

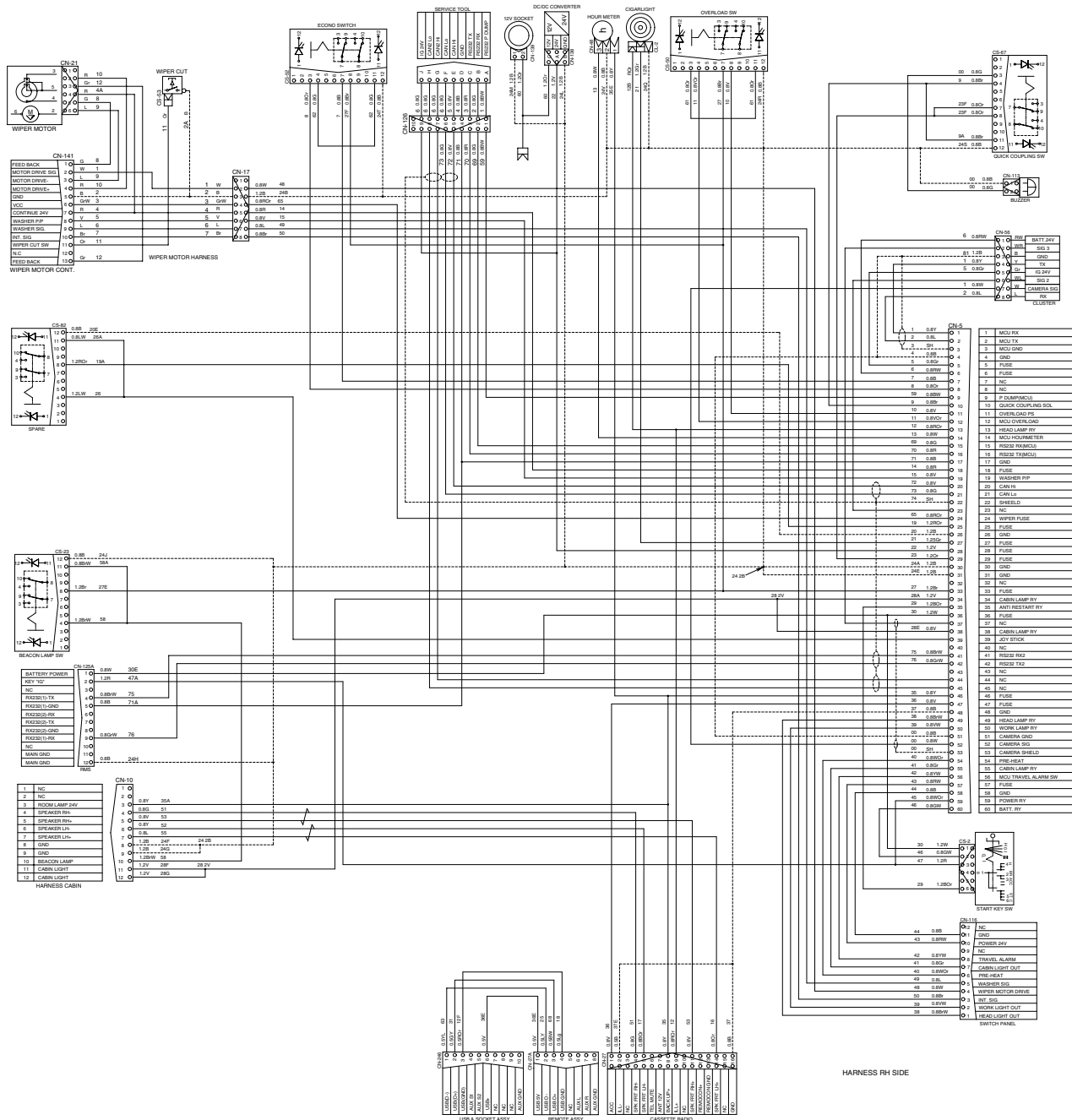
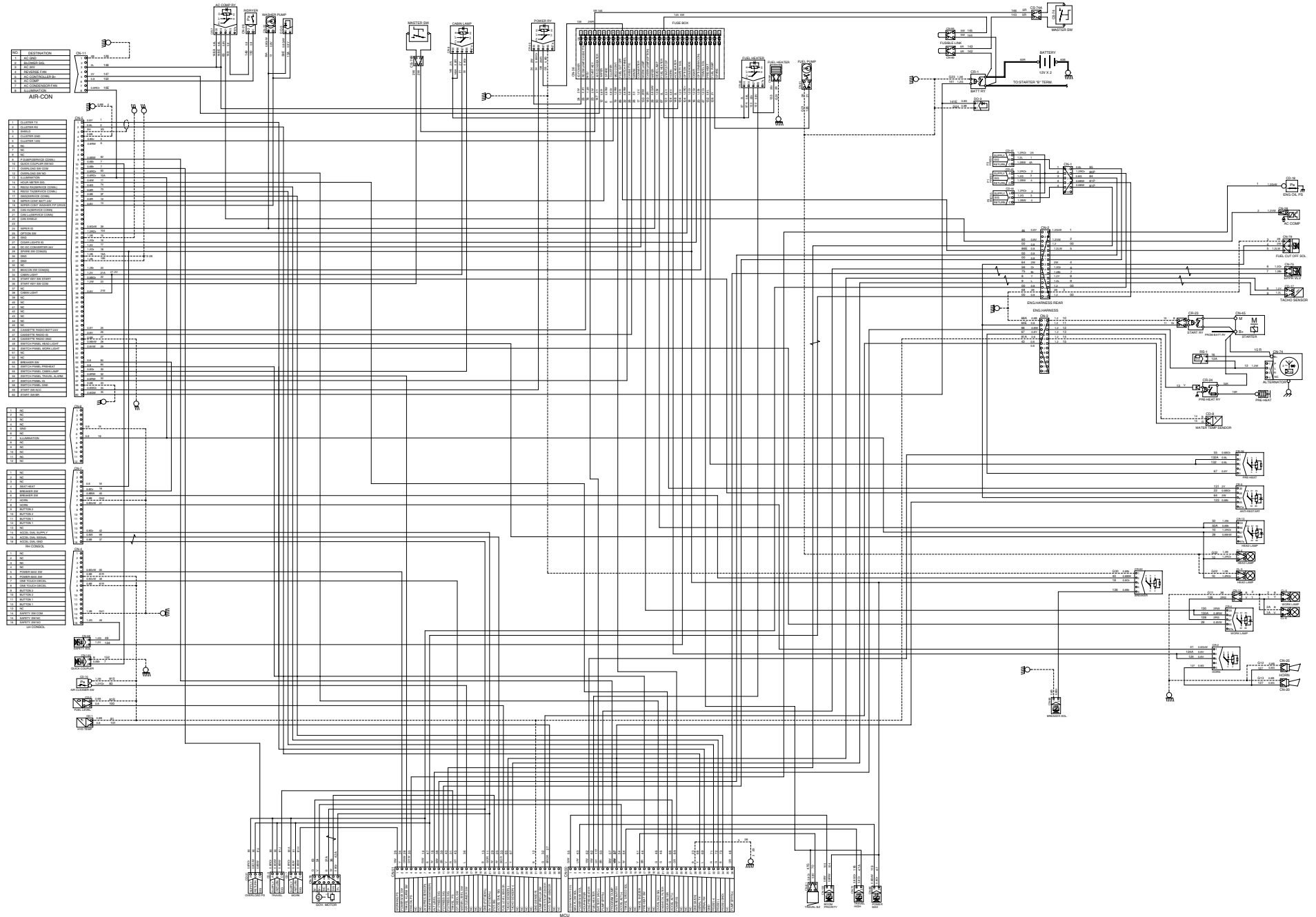

ELECTRICAL CIRCUIT (2/2, CLUSTER TYPE 2)

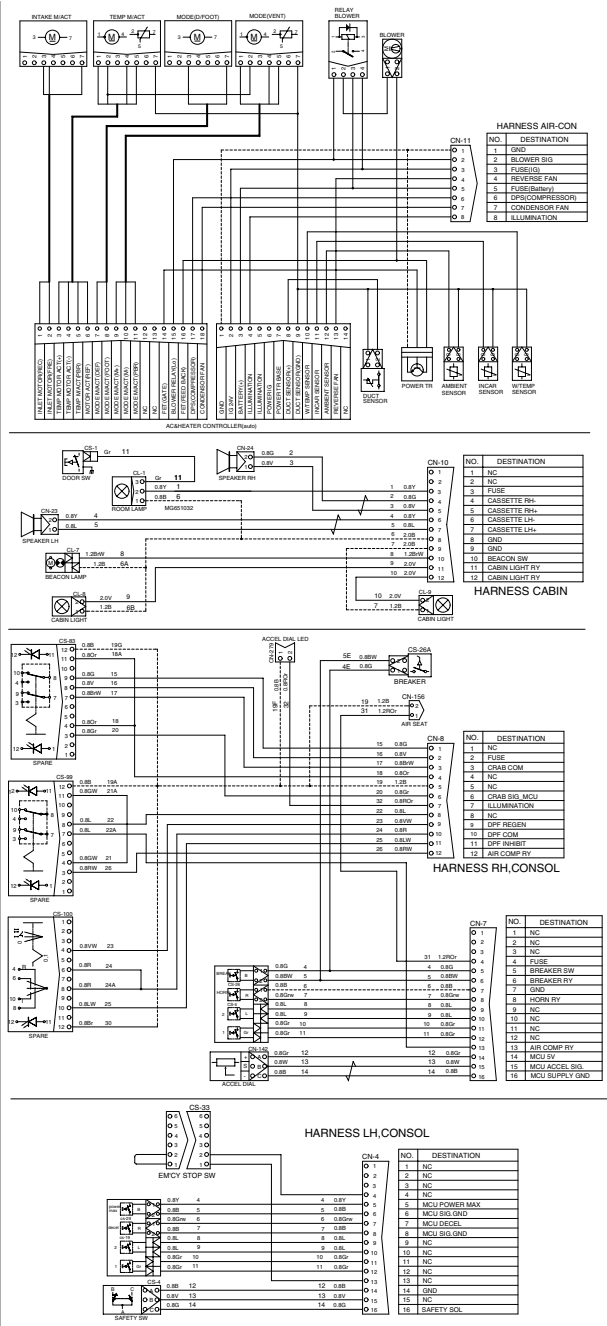
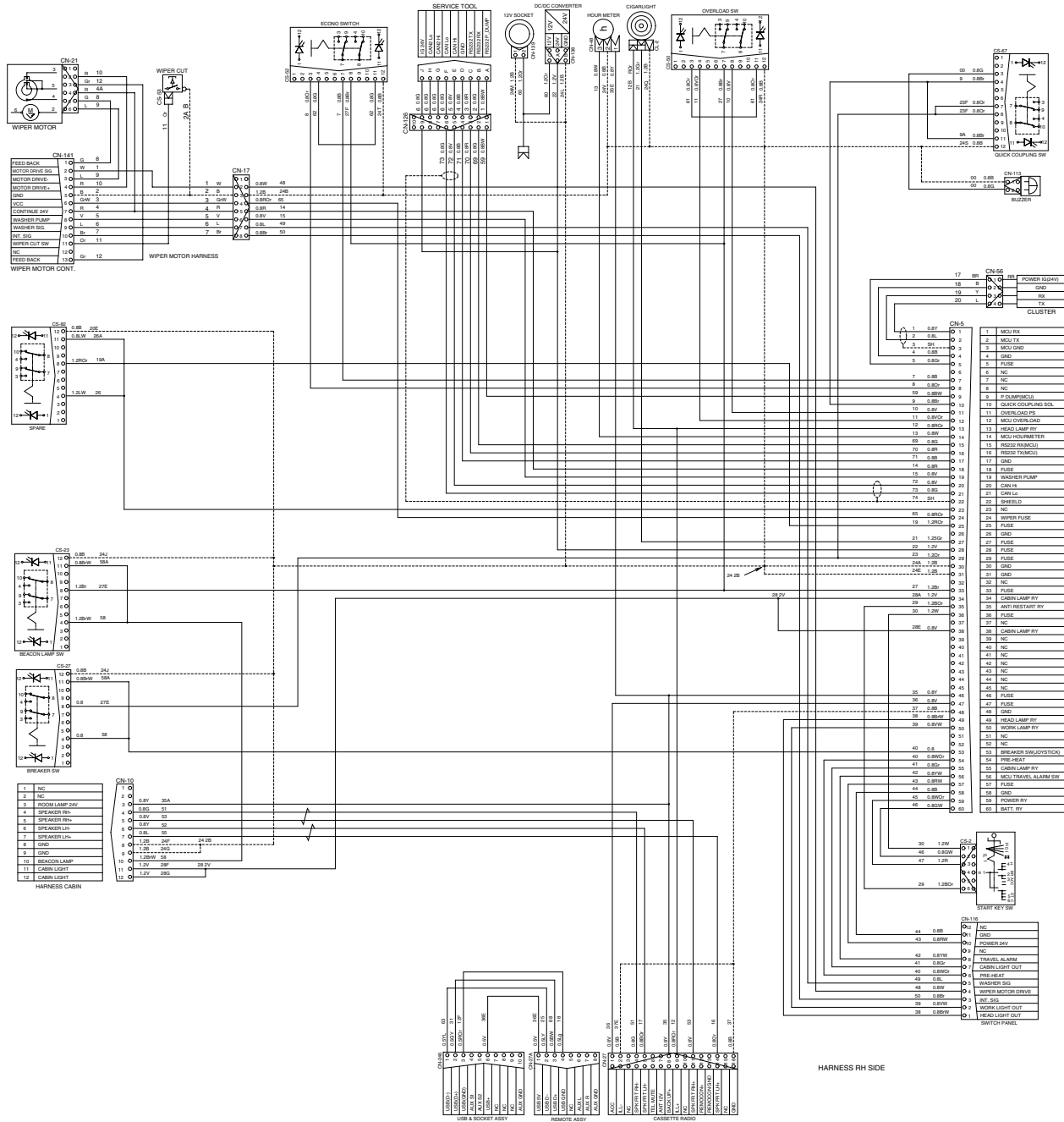

MEMORANDUM

HYUNDAI HEAVY INDUSTRIES CO., LTD  
CONSTRUCTION EQUIPMENT DIV.

## 1. POWER CIRCUIT (CLUSTER TYPE 1)

The negative terminal of battery is grounded to the machine chassis through master switch.  
When the start switch is in the OFF position, the current flows from the positive battery terminal as shown below.

### 1) OPERATING FLOW

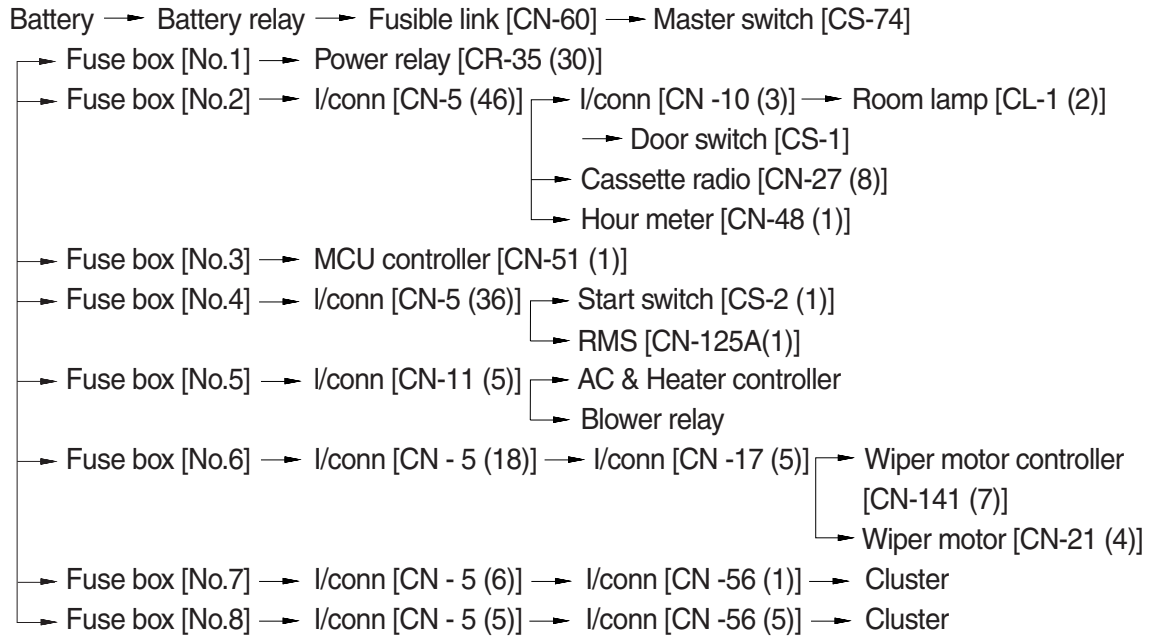

※ I/conn : Intermediate connector

### 2) CHECK POINT

Engine	Start switch	Check point	Voltage
OFF	OFF	① - GND (battery 1EA)	10~12.5V
		② - GND (battery 2EA)	20~25V
		③ - GND (battery 2EA)	20~25V
		④ - GND (fusible link)	20~25V

※ GND : Ground

# POWER CIRCUIT (CLUSTER TYPE 1)

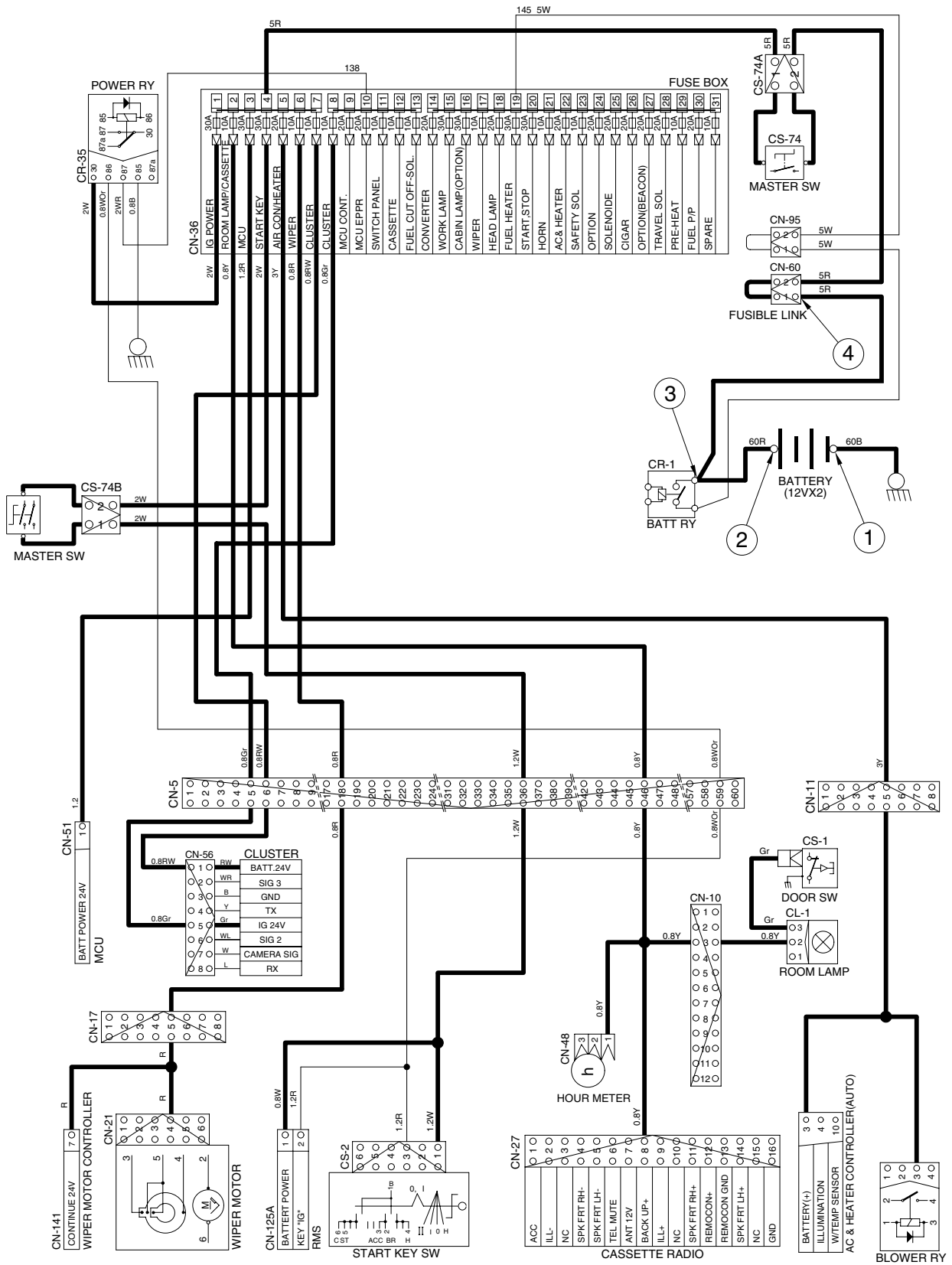

3009S4EL07

## ■ POWER CIRCUIT (CLUSTER TYPE 2)

The negative terminal of battery is grounded to the machine chassis through master switch.  
When the start switch is in the OFF position, the current flows from the positive battery terminal as shown below.

### 1) OPERATING FLOW

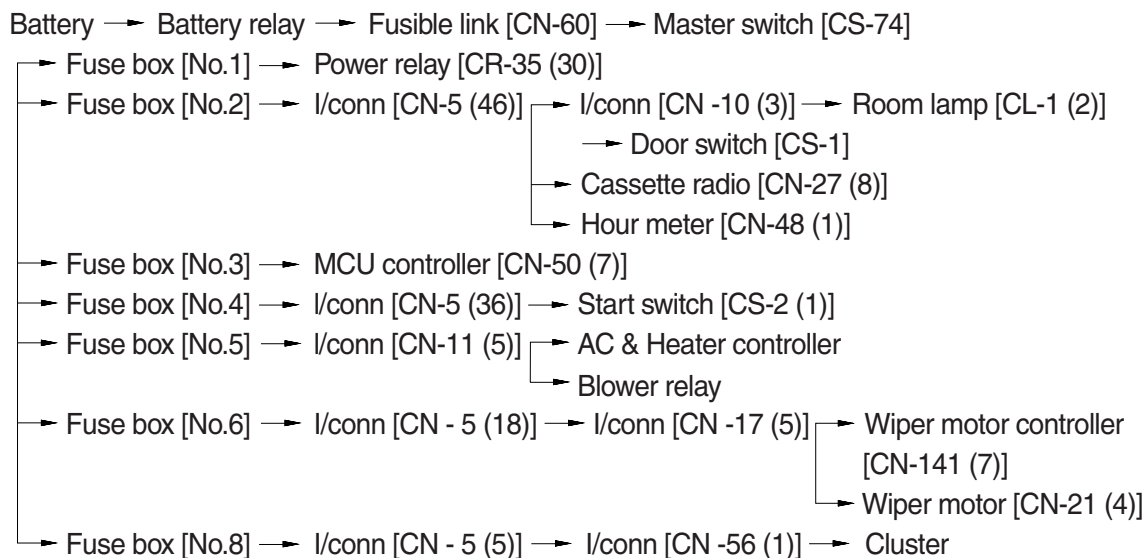

※ I/conn : Intermediate connector

### 2) CHECK POINT

Engine	Start switch	Check point	Voltage
OFF	OFF	① - GND (battery 1EA) ② - GND (battery 2EA) ③ - GND (battery 2EA) ④ - GND (fusible link)	10~12.5V 20~25V 20~25V 20~25V

※ GND : Ground



# POWER CIRCUIT (CLUSTER TYPE 2)

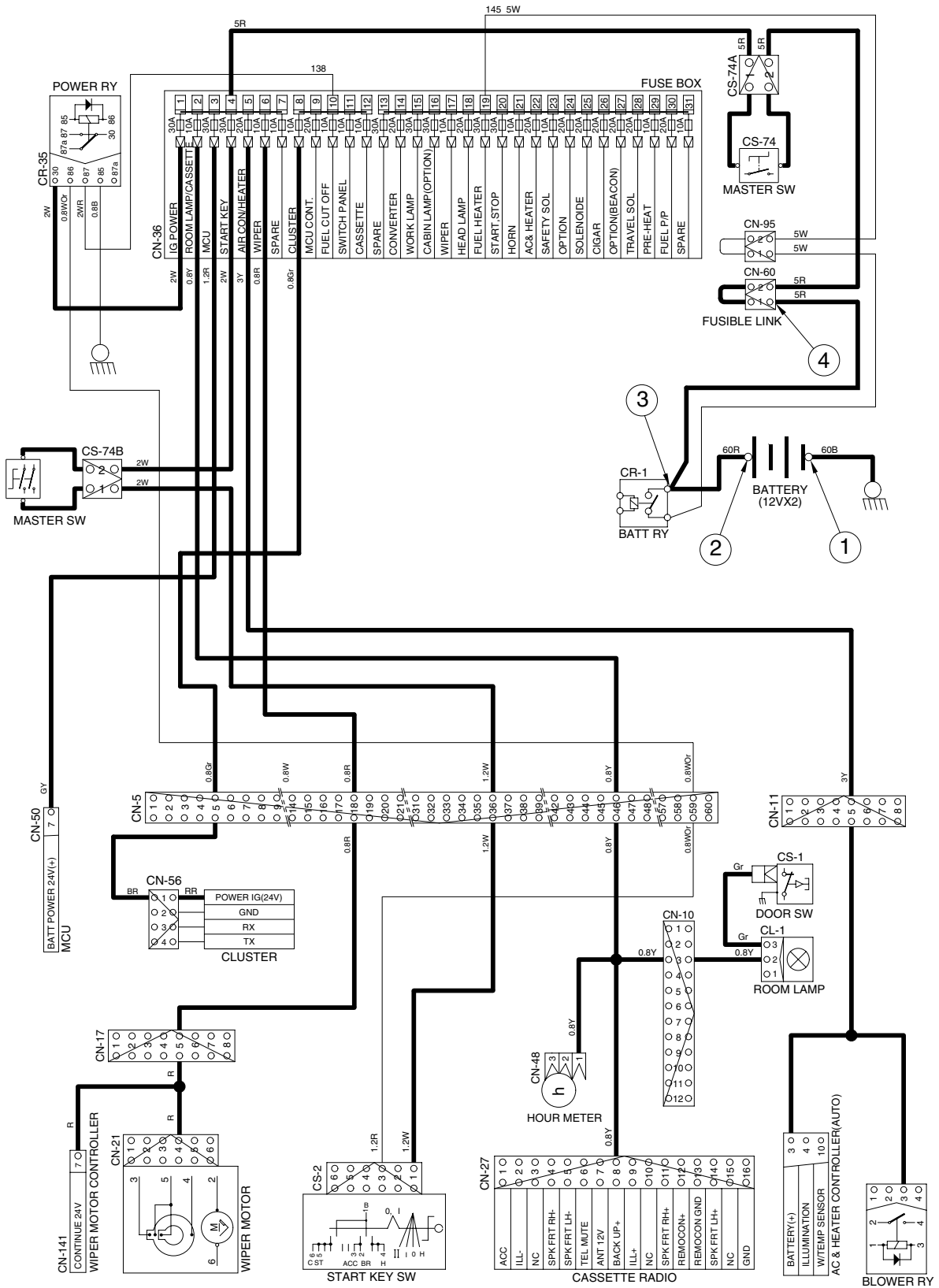

3009S4EL08

## 2. STARTING CIRCUIT (CLUSTER TYPE 1)

### 1) OPERATING FLOW

Battery(+) terminal → Battery relay [CR-1] → Fusible link [CN-60] → Master switch [CS-74]  
 → Fuse box [No.4] → Master switch [CS-74B] → I/conn [CN-5(36)] → Start switch [CS-2(1)]

#### (1) When start key switch is in ON position

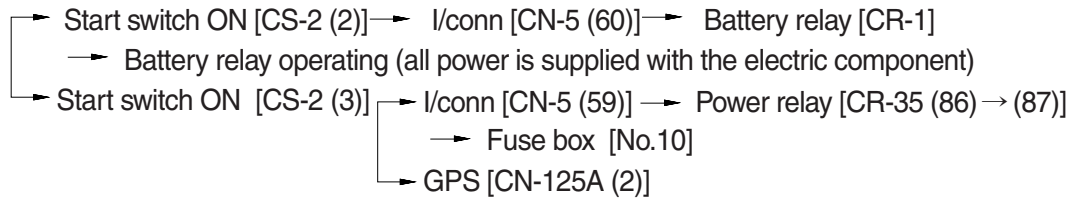

#### (2) When start key switch is in START position

Start switch START [CS-2 (6)] → I/conn [CN-5 (35)] → Anti-restart relay [CR-5 (86) → (87)]  
 → I/conn [CN-3 (2)] → Start relay [CR-23]  
 → I/conn [CN-2 (8)] → Fuel cut off solenoid

### 2) CHECK POINT

Engine	Start switch	Check point	Voltage
OPERATING	START	① - GND (battery) ② - GND (start key) ③ - GND (battery relay M4) ④ - GND (starter B <sup>+</sup> ) ⑤ - GND (starter M) ⑥ - GND (start relay) ⑦ - GND (battery relay M8)	20~25V

※ GND : Ground

# STARTING CIRCUIT (CLUSTER TYPE 1)

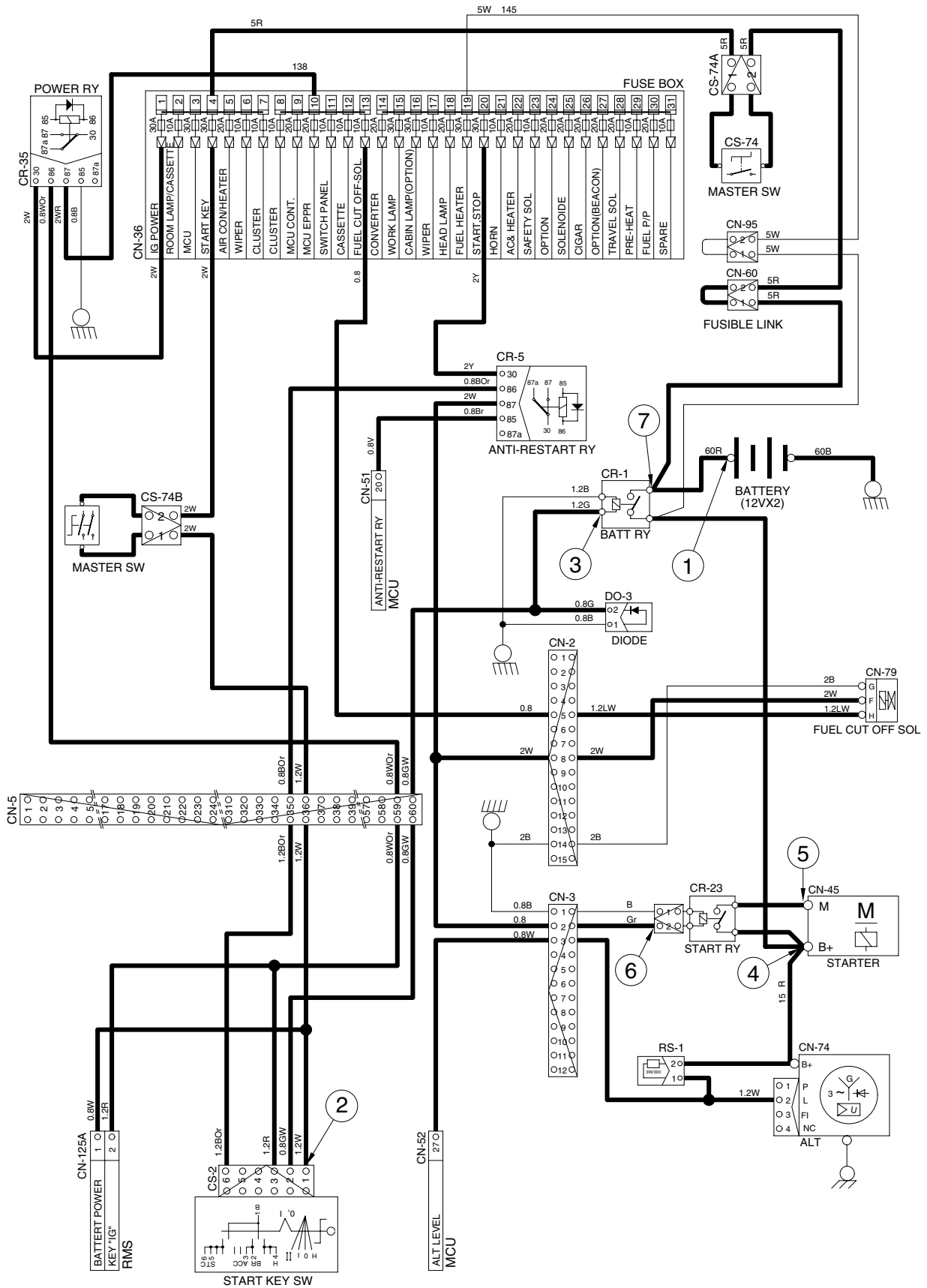

3009S4EL09

## ■ STARTING CIRCUIT (CLUSTER TYPE 2)

### 1) OPERATING FLOW

Battery(+) terminal → Battery relay [CR-1] → Fusible link [CN-60] → Master switch [CS-74]  
 → Fuse box [No.4] → Master switch [CS-74B] → I/conn [CN-5(36)] → Start switch [CS-2(1)]

#### (1) When start key switch is in ON position

→ Start switch ON [CS-2 (2)] → I/conn [CN-5 (60)] → Battery relay [CR-1]  
 → Battery relay operating (all power is supplied with the electric component)  
 → Start switch ON [CS-2 (3)] → I/conn [CN-5 (59)] → Power relay [CR-35 (86) → (87)]  
 → Fuse box [No.10]

#### (2) When start key switch is in START position

Start switch START [CS-2 (6)] → I/conn [CN-5 (35)] → Anti-restart relay [CR-5 (86) → (87)]  
 → I/conn [CN-3 (2)] → Start relay [CR-23]  
 → I/conn [CN-2 (8)] → Fuel cut off solenoid

### 2) CHECK POINT

Engine	Start switch	Check point	Voltage
OPERATING	START	① - GND (battery) ② - GND (start key) ③ - GND (battery relay M4) ④ - GND (starter B <sup>+</sup> ) ⑤ - GND (starter M) ⑥ - GND (start relay) ⑦ - GND (battery relay M8)	20~25V

※ GND : Ground



### 3. CHARGING CIRCUIT (CLUSTER TYPE 1)

When the starter is activated and the engine is started, the operator releases the key switch to the ON position.

Charging current generated by operating alternator flows into the battery through the battery relay [CR-1].

The current also flows from alternator to each electrical component and controller through the fuse box.

#### 1) OPERATING FLOW

##### (1) Warning flow

Alternator "I" terminal → I/conn [CN-3 (3)] → MCU alternator level [CN-52 (27)]

Cluster charging warning lamp (Via serial interface)

##### (2) Charging flow

Alternator "B+" terminal → Battery relay (M8) → Battery (+) terminal  
 → Fusible link [CN-60] → Master switch [CS-74]  
 → Fuse box

#### 2) CHECK POINT

Engine	Start switch	Check point	Voltage
Run	ON	① - GND (battery voltage) ② - GND (battery relay) ③ - GND (alternator B <sup>+</sup> terminal) ④ - GND (alternator I terminal) ⑤ - GND (MCU)	20~30V

※ GND : Ground

# CHARGING CIRCUIT (CLUSTER TYPE 1)

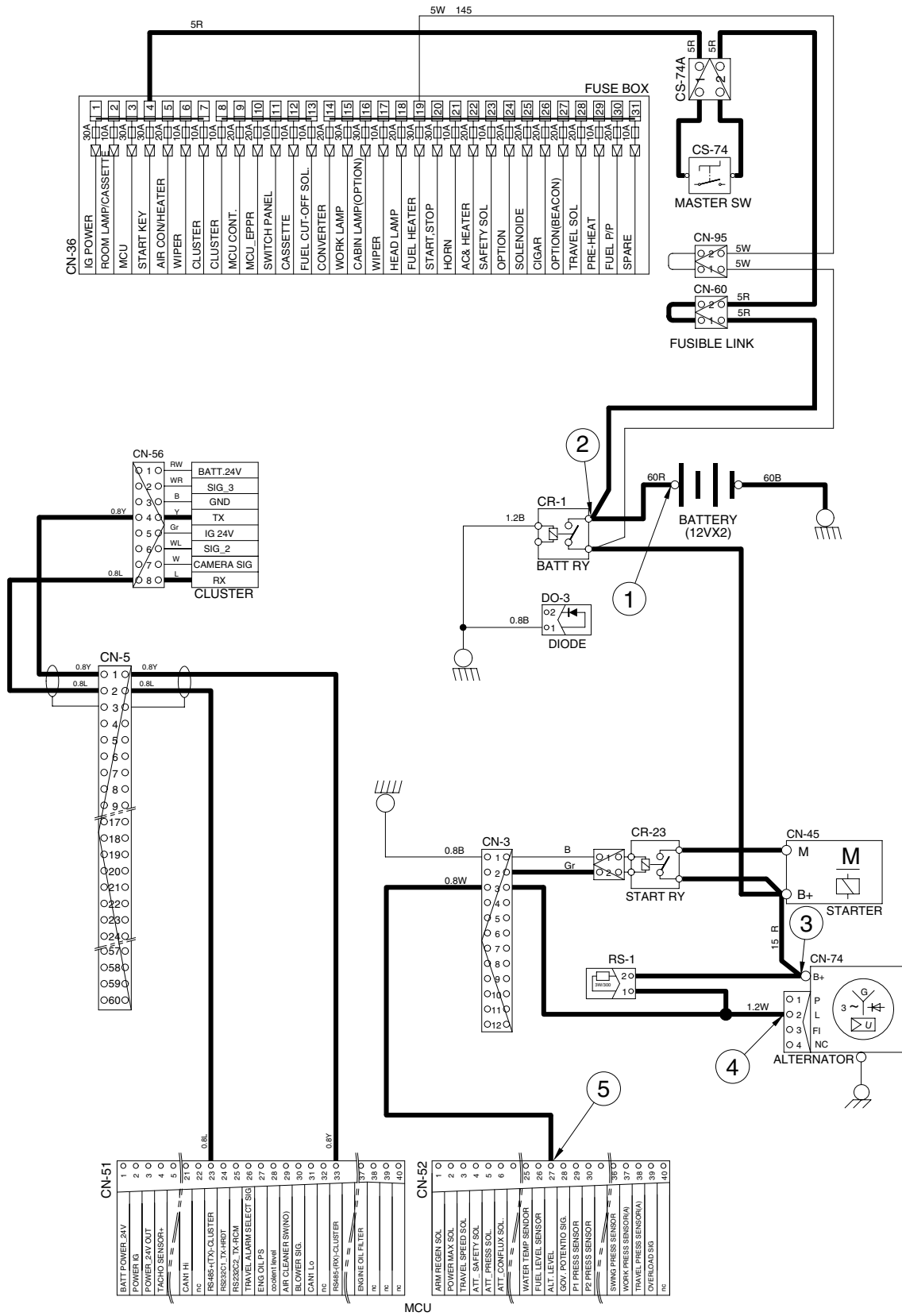

## ■ CHARGING CIRCUIT (CLUSTER TYPE 2)

When the starter is activated and the engine is started, the operator releases the key switch to the ON position.

Charging current generated by operating alternator flows into the battery through the battery relay [CR-1].

The current also flows from alternator to each electrical component and controller through the fuse box.

### 1) OPERATING FLOW

#### (1) Warning flow

Alternator "I" terminal → I/conn [CN-3 (3)] → MCU alternator level [CN-51 (9)]

Cluster charging warning lamp (Via serial interface)

#### (2) Charging flow

Alternator "B+" terminal → Battery relay (M8) → Battery (+) terminal  
 → Fusible link [CN-60] → Master switch [CS-74]  
 → Fuse box

### 2) CHECK POINT

Engine	Start switch	Check point	Voltage
Run	ON	① - GND (battery voltage) ② - GND (battery relay) ③ - GND (alternator B <sup>+</sup> terminal) ④ - GND (alternator I terminal) ⑤ - GND (MCU)	20~30V

※ GND : Ground



# CHARGING CIRCUIT (CLUSTER TYPE 2)

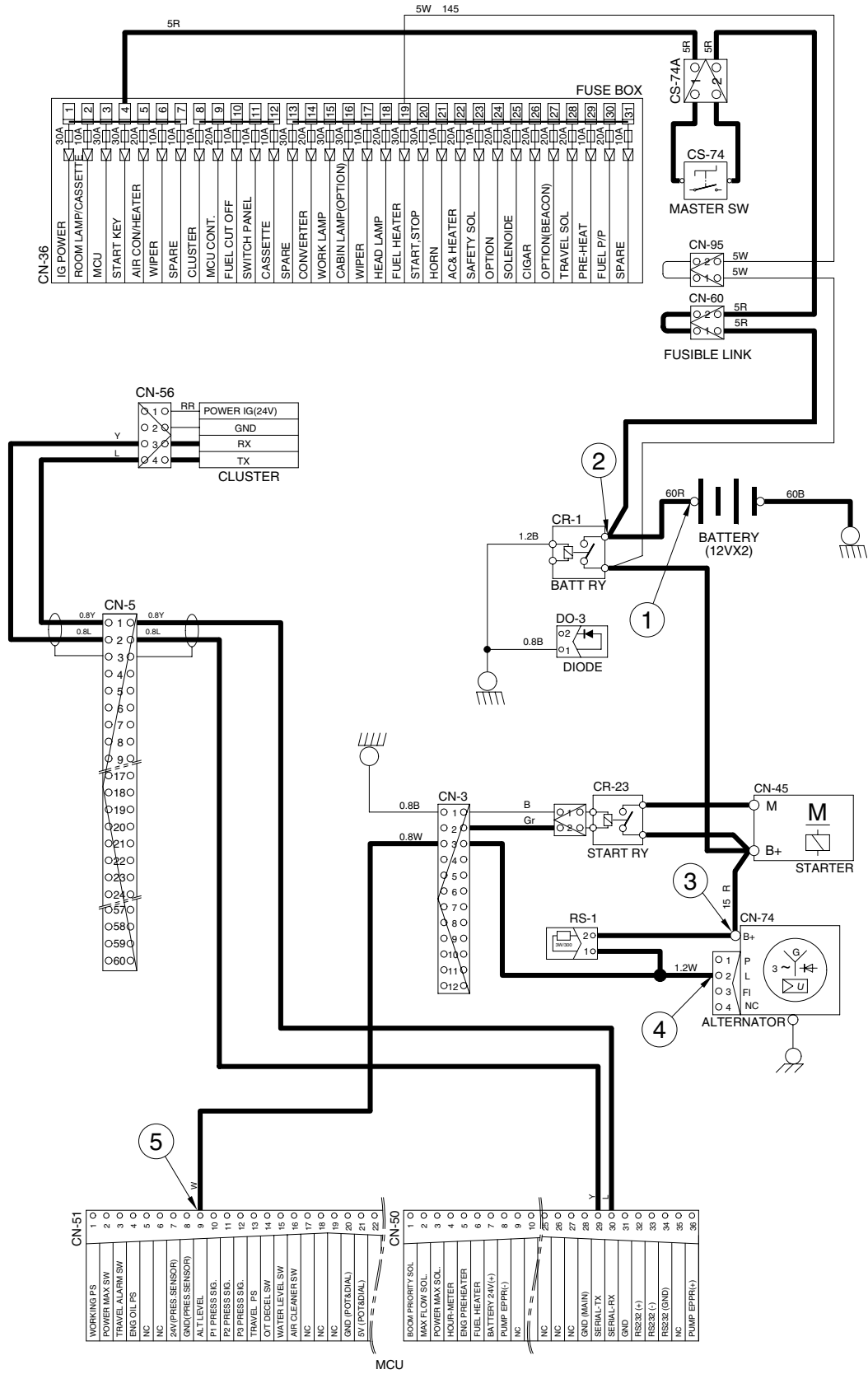

## 4. HEAD AND WORK LIGHT CIRCUIT (CLUSTER TYPE 1)

### 1) OPERATING FLOW

Fuse box (No.15) → Work light relay [CR-4 (30, 86)]

Fuse box (No.18) → Head light relay [CR-13 (30, 86)]

#### (1) Head light switch ON

Head light switch ON [CN-116 (1)] → I/conn [CN-5 (49)] → Head light relay [CR-13 (85) → (87)]

→ Head light ON [CL-3 (1), CL-4 (1)]

→ I/conn [CN-11 (8)] → AC & Heater controller illumination ON [4]

→ I/conn [CN-5 (13)] → Cassette radio illumination ON [CN-27 (9)]

→ Cigar light [CL-2]

→ I/conn [CN-8 (7)] → Accel dial LED ON

#### (2) Work light switch ON

Work light switch ON [CN-116 (2)] → I/conn [CN-5 (50)] → Work light relay [CR-4 (85) → (87)]

→ I/conn [CN-12 (1)] → Work light ON [CL-5 (2), CL-6 (2)]

### 2) CHECK POINT

Engine	Start switch	Check point	Voltage
STOP	ON	① - GND (fuse box) ② - GND (switch power output) ③ - GND (head light relay) ④ - GND (head light) ⑤ - GND (fuse box) ⑥ - GND (switch power output) ⑦ - GND (work light relay) ⑧ - GND (work light)	20~25V

※ GND : Ground

# HEAD AND WORK LIGHT CIRCUIT (CLUSTER TYPE 1)

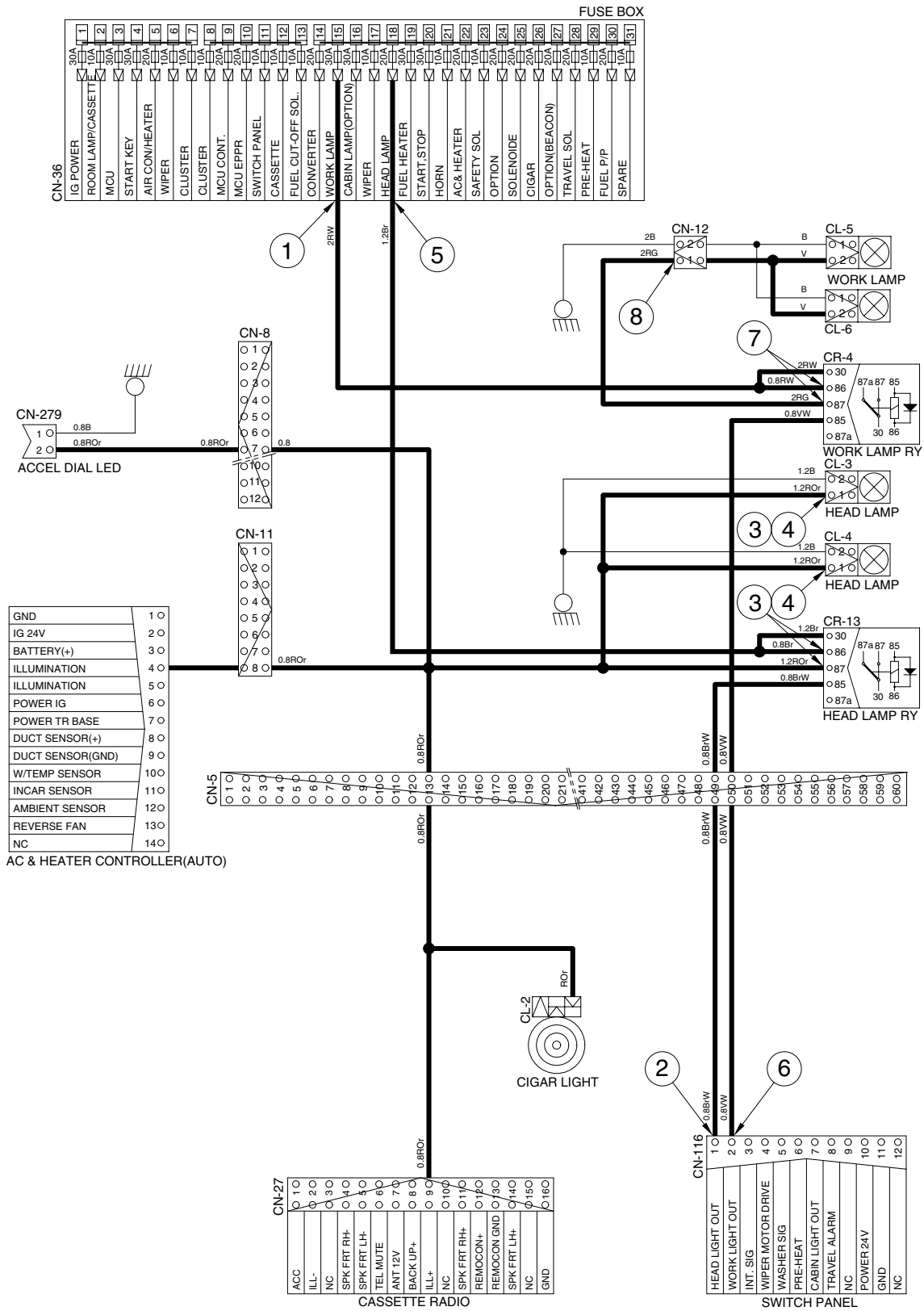

## ■ HEAD AND WORK LIGHT CIRCUIT (CLUSTER TYPE 2)

### 1) OPERATING FLOW

Fuse box (No.15) → Work light relay [CR-4 (30, 86)]

Fuse box (No.18) → Head light relay [CR-13 (30, 86)]

#### (1) Head light switch ON

Head light switch ON [CN-116 (1)] → I/conn [CN-5 (49)] → Head light relay [CR-13 (85) → (87)]

→ Head light ON [CL-3 (1), CL-4 (1)]

→ I/conn [CN-11 (8)] → AC & Heater controller illumination ON [4]

→ I/conn [CN-5 (13)] → Cassette radio illumination ON [CN-27 (9)]

→ I/conn [CN-8 (7)] → Accel dial LED ON

→ I/conn [CN-5 (13)] → Cigar light [CL-2]

#### (2) Work light switch ON

Work light switch ON [CN-116 (2)] → I/conn [CN-5 (50)] → Work light relay [CR-4 (85) → (87)]

→ I/conn [CN-12 (1)] → Work light ON [CL-5 (2), CL-6 (2)]

### 2) CHECK POINT

Engine	Start switch	Check point	Voltage
STOP	ON	① - GND (fuse box) ② - GND (switch power output) ③ - GND (head light relay) ④ - GND (head light) ⑤ - GND (fuse box) ⑥ - GND (switch power output) ⑦ - GND (work light relay) ⑧ - GND (work light)	20~25V

※ GND : Ground

# HEAD AND WORK LIGHT CIRCUIT (CLUSTER TYPE 2)

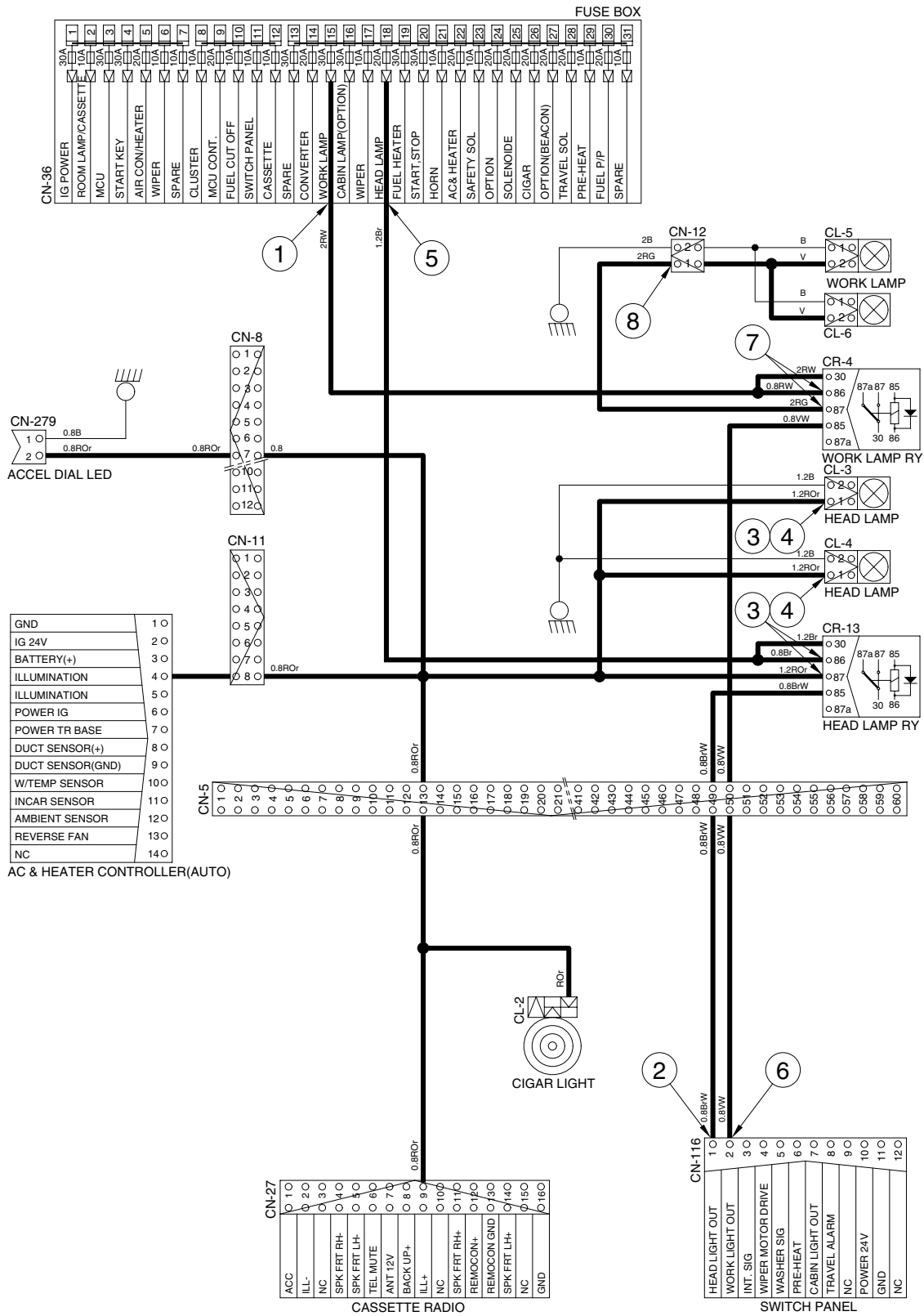

## 5. BEACON LAMP AND CAB LIGHT CIRCUIT (CLUSTER TYPE 1)

### 1) OPERATING FLOW

Fuse box (No. 27) → I/conn [CN-5 (33)] → Beacon lamp switch [CN-23 (8)]

Fuse box (No.16) → Cab light relay [CR-9 (30, 86)]

#### (1) Beacon lamp switch ON

Beacon lamp switch ON [CS-23 (4)] → Switch indicator lamp ON [CS-23 (11)]  
 → I/conn [CN-10 (10)] → Beacon lamp ON [CL-7]

#### (2) Cab light switch ON

Cab light switch ON [CN-116 (7)] → I/conn [CN-5 (55)] → Cabin light relay [CR-9 (85) → (87)]  
 → I/conn [CN-5 (34)] → I/conn [CN-10 (11, 12)] → Cab light ON [CL-8 (2), CL-9 (2)]

### 2) CHECK POINT

Engine	Start switch	Check point	Voltage
STOP	ON	① - GND (fuse box) ② - GND (switch power input) ③ - GND (switch power output) ④ - GND (beacon lamp) ⑤ - GND (fuse box) ⑥ - GND (cab light relay) ⑦ - GND (switch power output) ⑧ - GND (cab light)	20~25V

※ GND : Ground

# BEACON LIGHT AND CAB LIGHT CIRCUIT (CLUSTER TYPE 1)

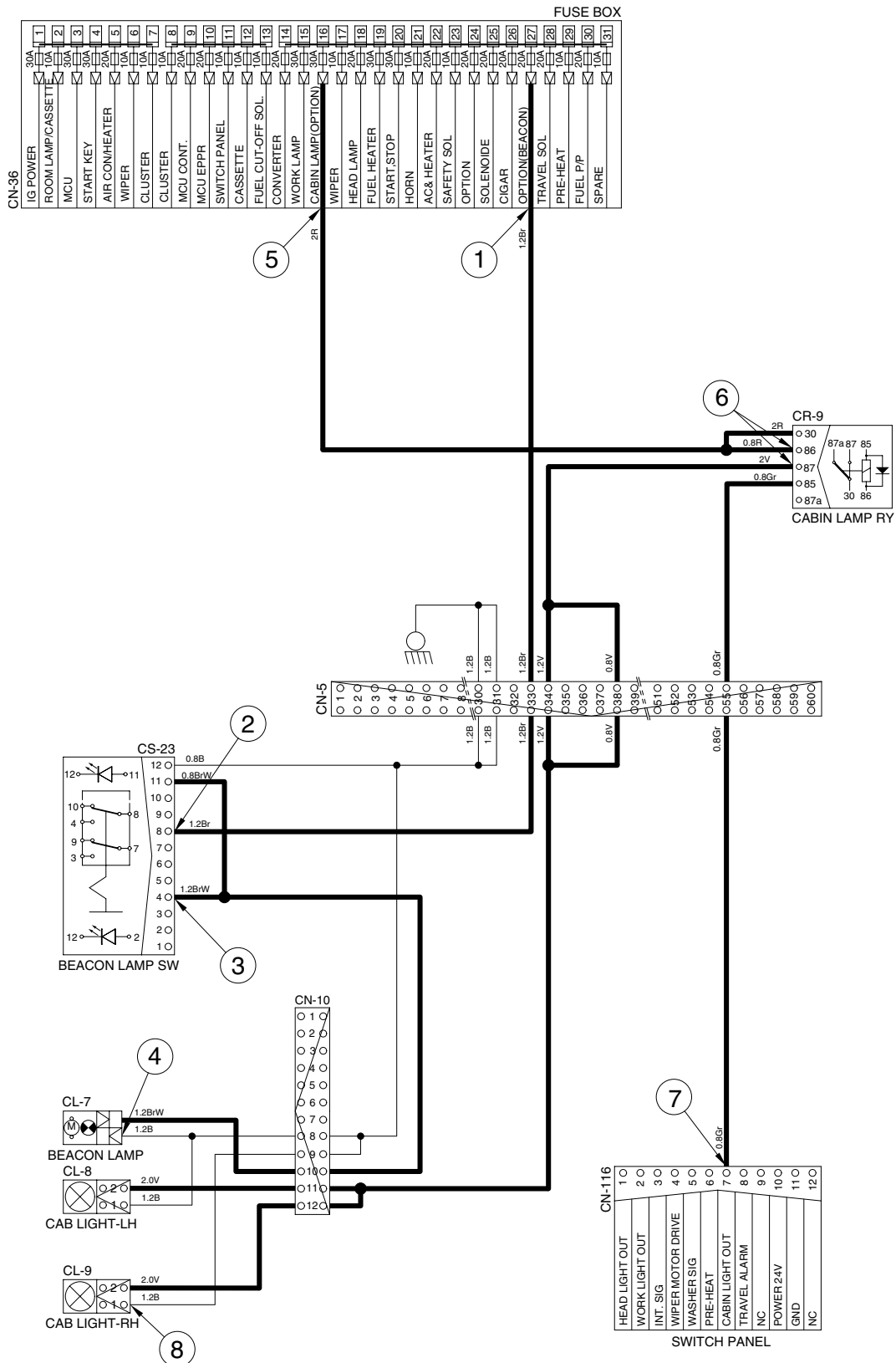

## ■ BEACON LAMP AND CAB LIGHT CIRCUIT (CLUSTER TYPE 2)

### 1) OPERATING FLOW

Fuse box (No. 27) → I/conn [CN-5 (33)] → Beacon lamp switch [CN-23 (8)]

Fuse box (No.16) → Cab light relay [CR-9 (30, 86)]

#### (1) Beacon lamp switch ON

Beacon lamp switch ON [CS-23 (4)] → Switch indicator lamp ON [CS-23 (11)]  
 → I/conn [CN-10 (10)] → Beacon lamp ON [CL-7]

#### (2) Cab light switch ON

Cab light switch ON [CN-116 (7)] → I/conn [CN-5 (55)] → Cabin light relay [CR-9 (85) → (87)]  
 → I/conn [CN-5 (34)] → I/conn [CN-10 (11, 12)] → Cab light ON [CL-8 (2), CL-9 (2)]

### 2) CHECK POINT

Engine	Start switch	Check point	Voltage
STOP	ON	① - GND (fuse box) ② - GND (switch power input) ③ - GND (switch power output) ④ - GND (beacon lamp) ⑤ - GND (fuse box) ⑥ - GND (cab light relay) ⑦ - GND (switch power output) ⑧ - GND (cab light)	20~25V

※ GND : Ground



# BEACON LAMP AND CAB LIGHT CIRCUIT (CLUSTER TYPE 2)

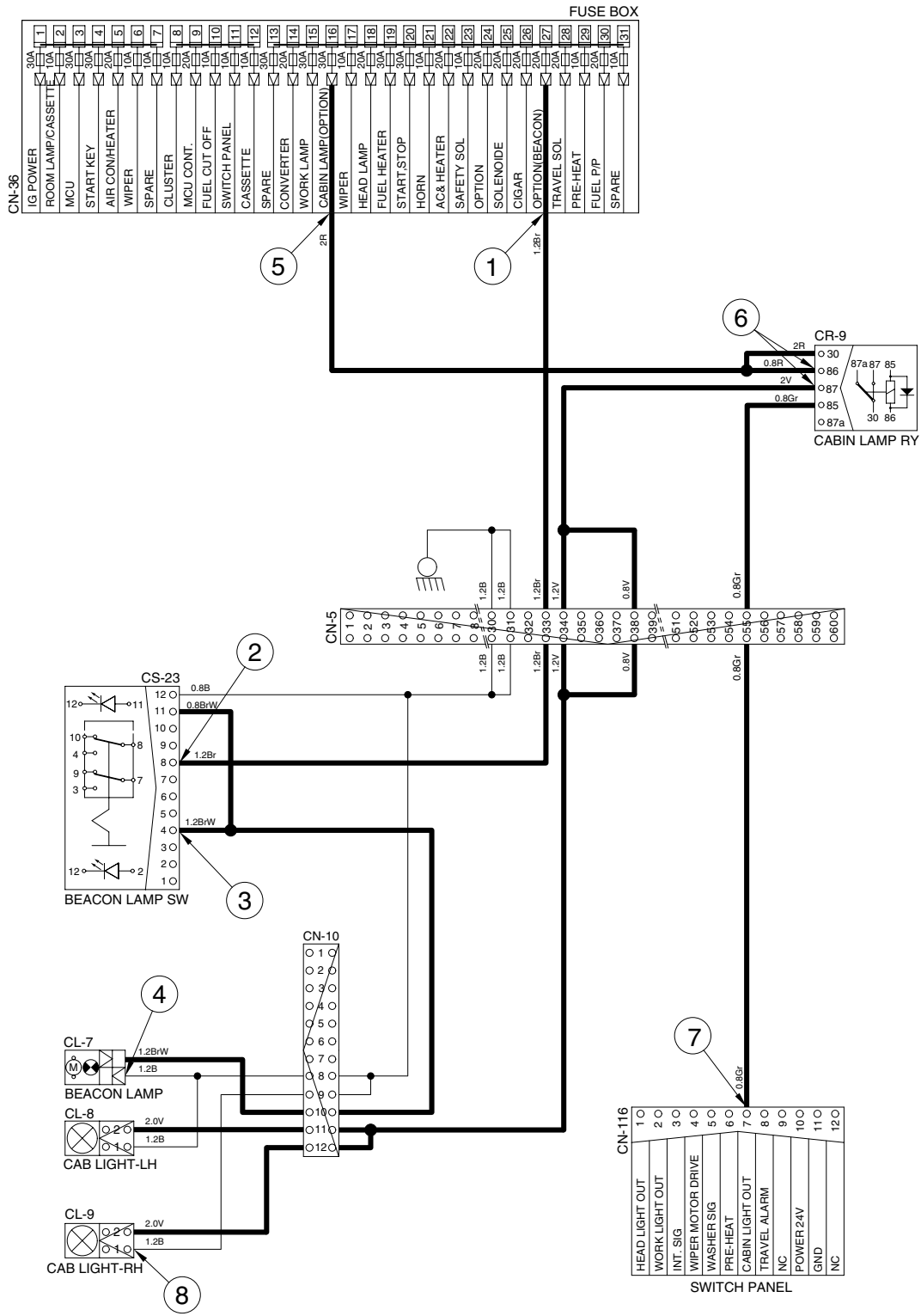

## 6. WIPER AND WASHER CIRCUIT (CLUSTER TYPE 1)

### 1) OPERATING FLOW

#### (1) Key switch ON

Fuse box (No.11) → I/conn [CN-5 (57)] → Switch panel [CN-116 (10)]

Fuse box (No.6) → I/conn [CN-5 (18)] → I/conn [CN-17 (5)] → Wiper motor controller [CN-141(7)]  
 → Wiper motor [CN-21(4)]

Fuse box (No.17) → I/conn [CN-5 (24)] → I/conn [CN-17 (4)] → Wiper motor controller [CN-141 (6)]  
 → Washer pump [CN-22 (2)]

#### (2) Wiper switch ON : 1st step (Intermittent)

Wiper switch ON [CN-116 (3)] → I/conn [CN-17 (8)] → Wiper motor controller [CN-141 (10) → (3)]  
 → Wiper motor intermittently operating [CN-21 (6)]

#### (3) Wiper switch ON : 2nd step (continual)

Wiper switch ON [CN-116(4)] → I/conn[CN-17(2)] → Wiper motor controller [CN-141(2) → (4)]  
 → Wiper motor operating [CN-21(2)]

#### (4) Washer switch ON

Washer switch ON [CN-116 (5)] → I/conn [CN-17 (7)] → Wiper motor controller [CN-141 (9) → (8)]  
 → I/conn [CN-17 (6)] → I/conn [CN-5 (19)] → Washer pump [CN-22 (1)] → Washer operating  
 Wiper switch ON [CN-116 (4)] → I/conn[CN-17 (2)] → Wiper motor controller [CN-141 (2) → (4)]  
 → Wiper motor operating [CN-21 (2)]

#### (5) Auto parking (when switch OFF)

Switch OFF [CN-116 (4)] → Wiper motor parking position by wiper motor controller

### 2) CHECK POINT

Engine	Start switch	Check point	Voltage
STOP	ON	① - GND (fuse box)	24V
		② - GND (switch power input)	
		③ - GND (switch power output)	0 ~ 5V
		④ - GND (wiper power input)	
		⑤ - GND (wiper power output)	24V
		⑥ - GND (wiper motor)	0 or 24V

※ GND : Ground

# WIPER AND WASHER CIRCUIT (CLUSTER TYPE 1)

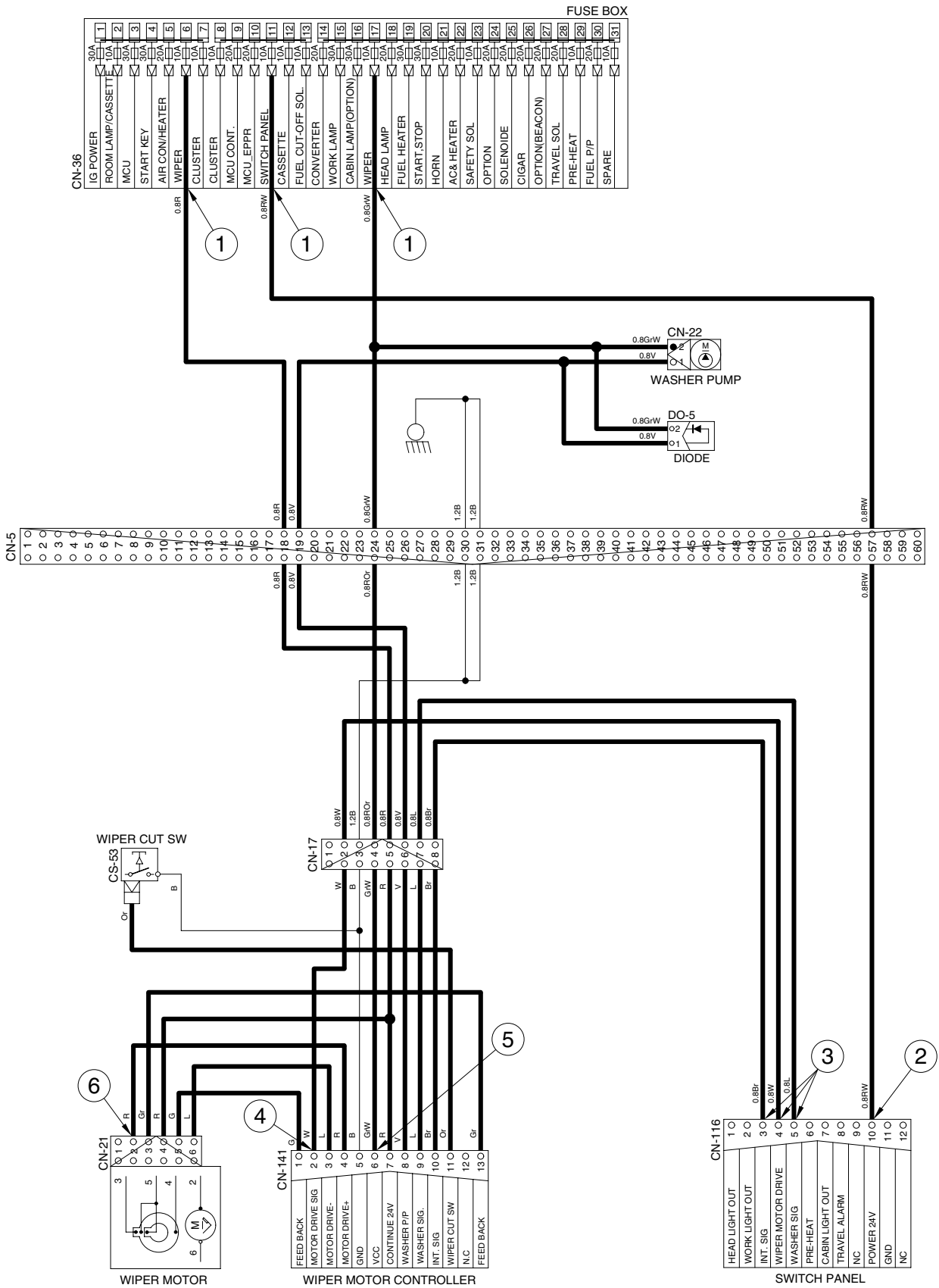

## ■ WIPER AND WASHER CIRCUIT (CLUSTER TYPE 2)

### 1) OPERATING FLOW

#### (1) Key switch ON

Fuse box (No.11) → I/conn [CN-5 (57)] → Switch panel [CN-116 (10)]

Fuse box (No.6) → I/conn [CN-5 (18)] → I/conn [CN-17 (5)] → Wiper motor controller [CN-141(7)]  
 → Wiper motor [CN-21(4)]

Fuse box (No.17) → I/conn [CN-5 (24)] → I/conn [CN-17 (4)] → Wiper motor controller [CN-141 (6)]  
 → Washer pump [CN-22 (2)]

#### (2) Wiper switch ON : 1st step (Intermittent)

Wiper switch ON [CN-116 (3)] → I/conn [CN-17 (8)] → Wiper motor controller [CN-141 (10) → (3)]  
 → Wiper motor intermittently operating [CN-21 (6)]

#### (3) Wiper switch ON : 2nd step (continual)

Wiper switch ON [CN-116(4)] → I/conn[CN-17(2)] → Wiper motor controller [CN-141(2) → (4)]  
 → Wiper motor operating [CN-21(2)]

#### (4) Washer switch ON

Washer switch ON [CN-116 (5)] → I/conn [CN-17 (7)] → Wiper motor controller [CN-141 (9) → (8)]  
 → I/conn [CN-17 (6)] → I/conn [CN-5 (19)] → Washer pump [CN-22 (1)] → Washer operating  
 Wiper switch ON [CN-116 (4)] → I/conn[CN-17 (2)] → Wiper motor controller [CN-141 (2) → (4)]  
 → Wiper motor operating [CN-21 (2)]

#### (5) Auto parking (when switch OFF)

Switch OFF [CN-116 (4)] → Wiper motor parking position by wiper motor controller

### 2) CHECK POINT

Engine	Start switch	Check point	Voltage
STOP	ON	① - GND (fuse box)	24V
		② - GND (switch power input)	
		③ - GND (switch power output)	0 ~ 5V
		④ - GND (wiper power input)	
		⑤ - GND (wiper power output)	
⑥ - GND (wiper motor)	0 or 24V		

※ GND : Ground

# WIPER AND WASHER CIRCUIT (CLUSTER TYPE 2)

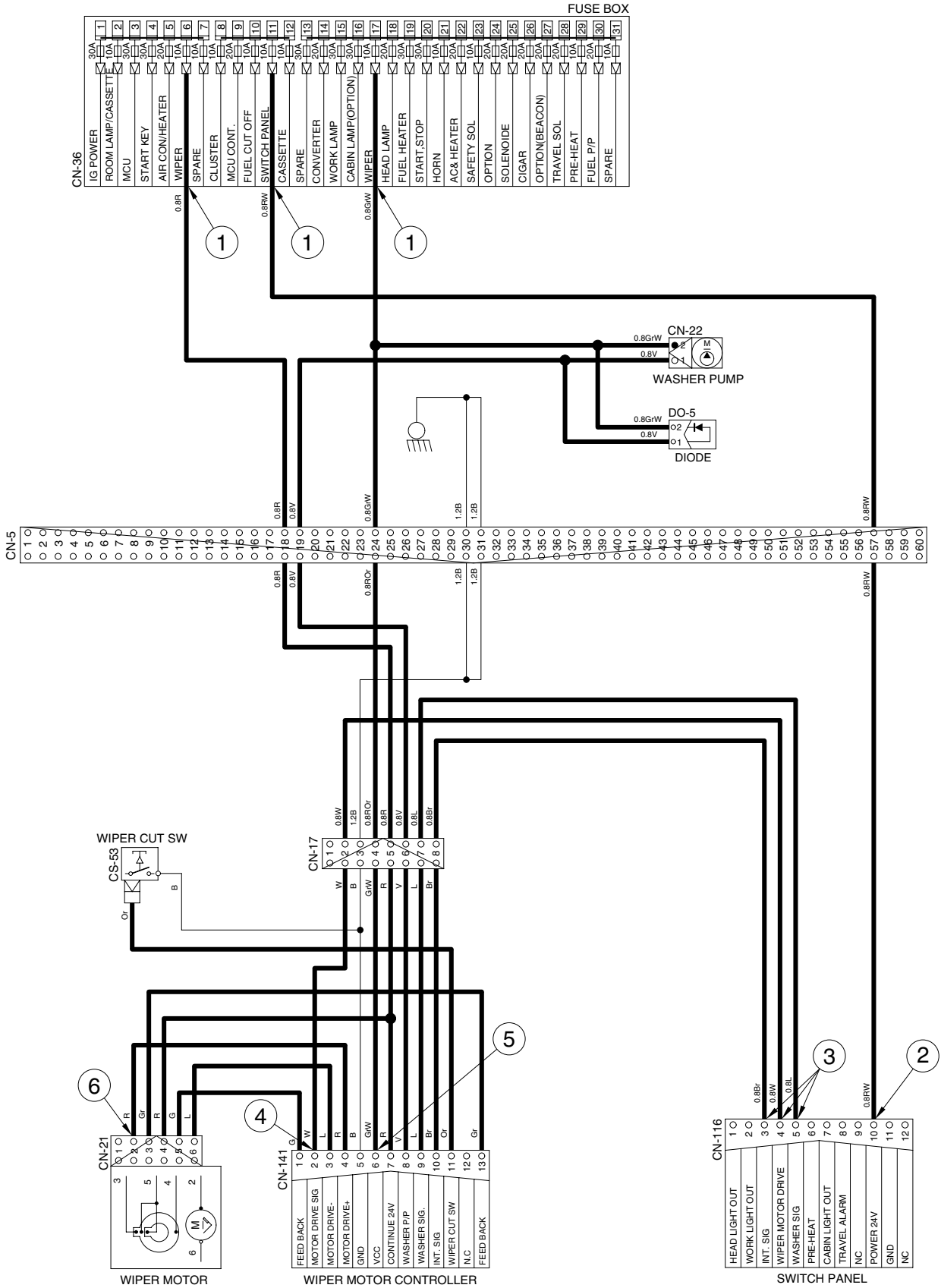

# CONTROLLER CIRCUIT (CLUSTER TYPE 1)

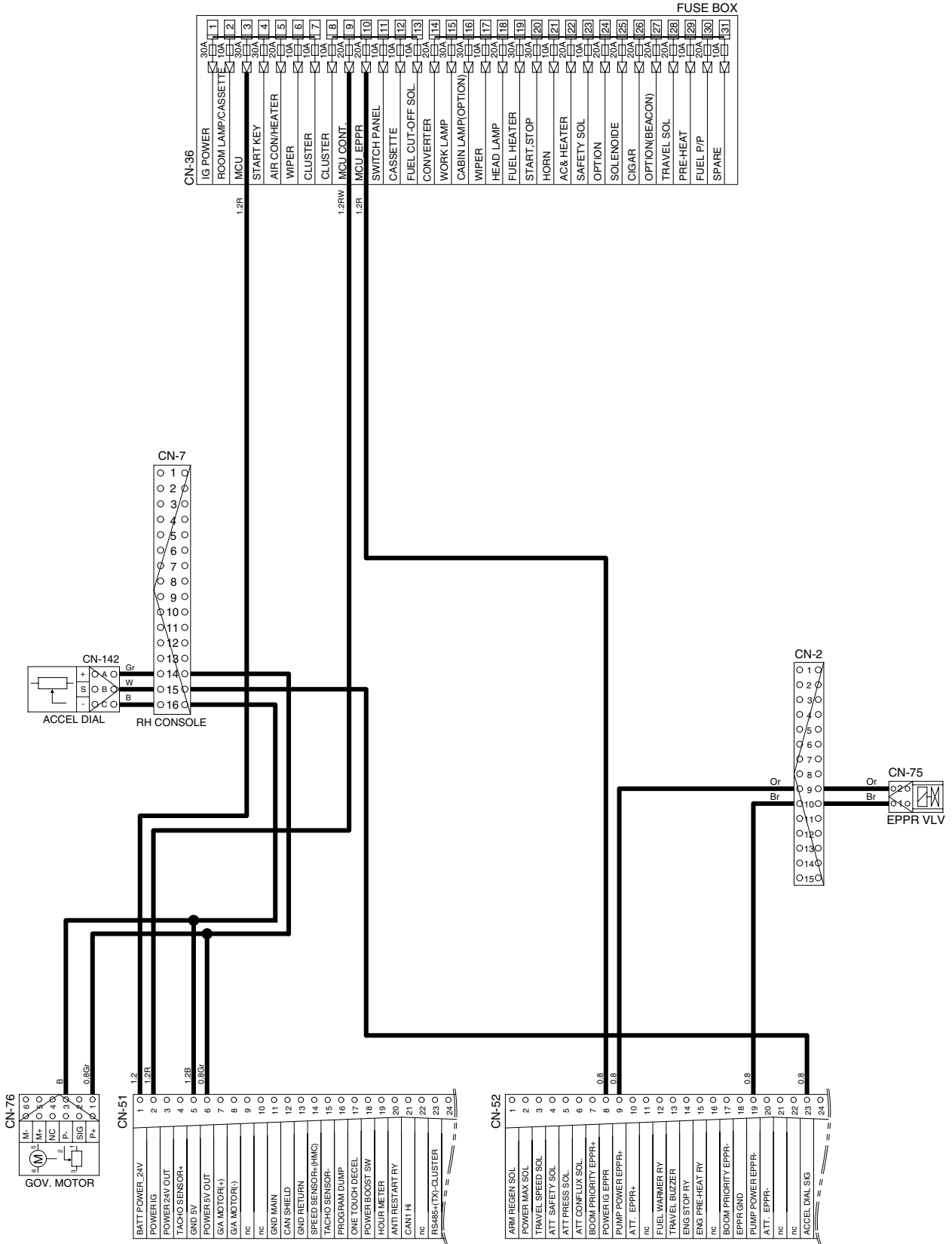

MCU

# CONTROLLER CIRCUIT (CLUSTER TYPE 2)

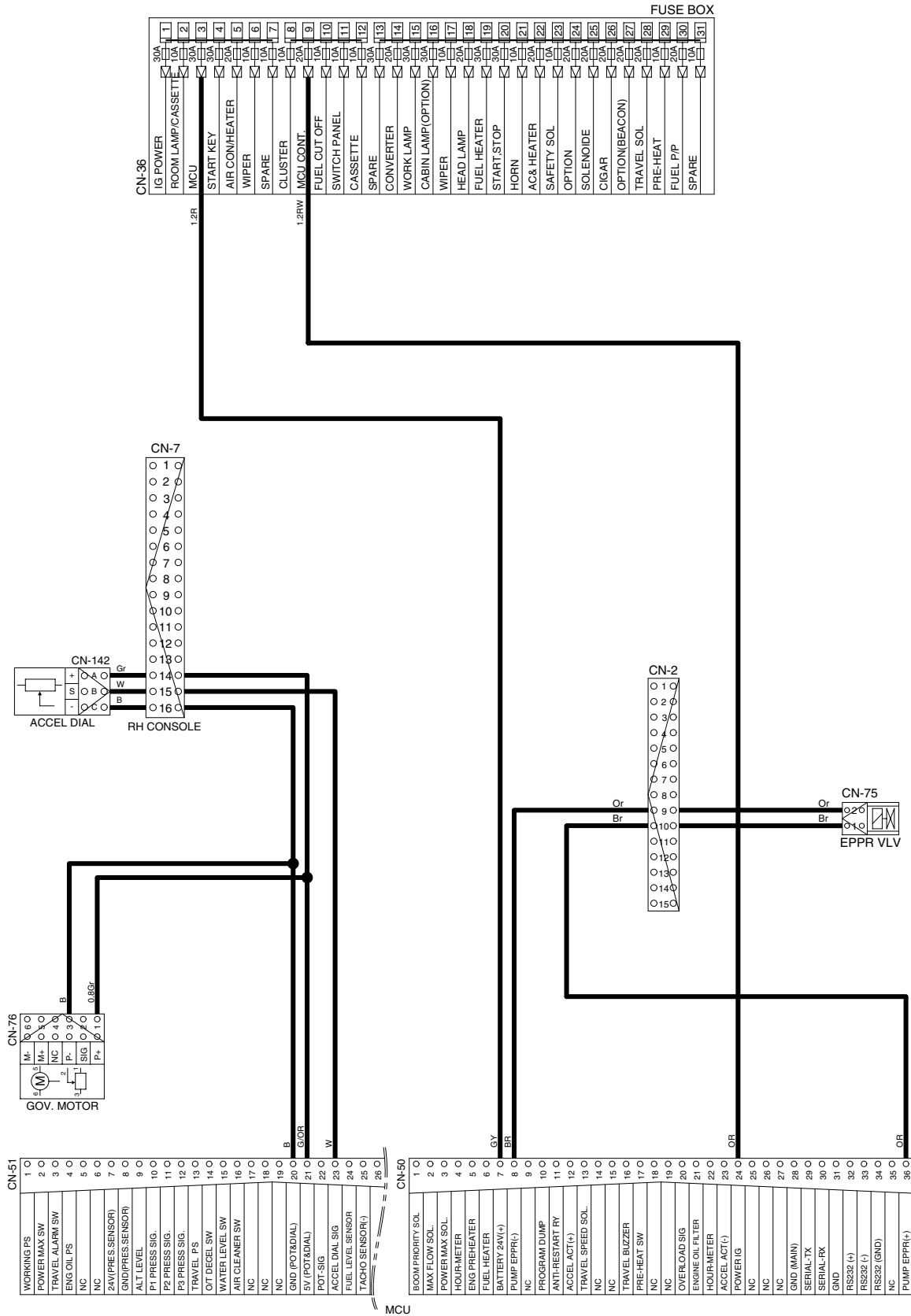

# MONITORING CIRCUIT (CLUSTER TYPE 1)

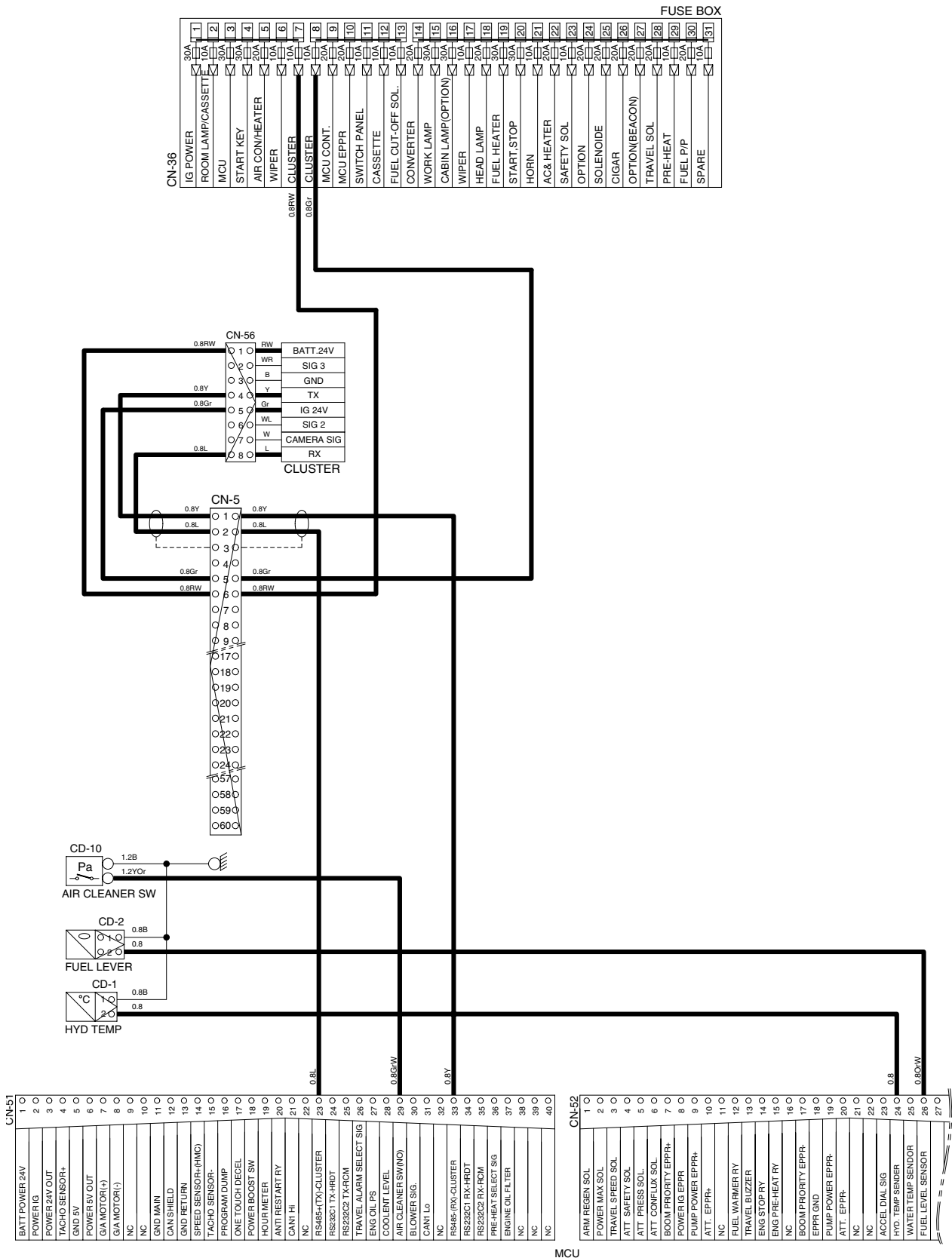

3009S4EL21



# MONITORING CIRCUIT (CLUSTER TYPE 2)

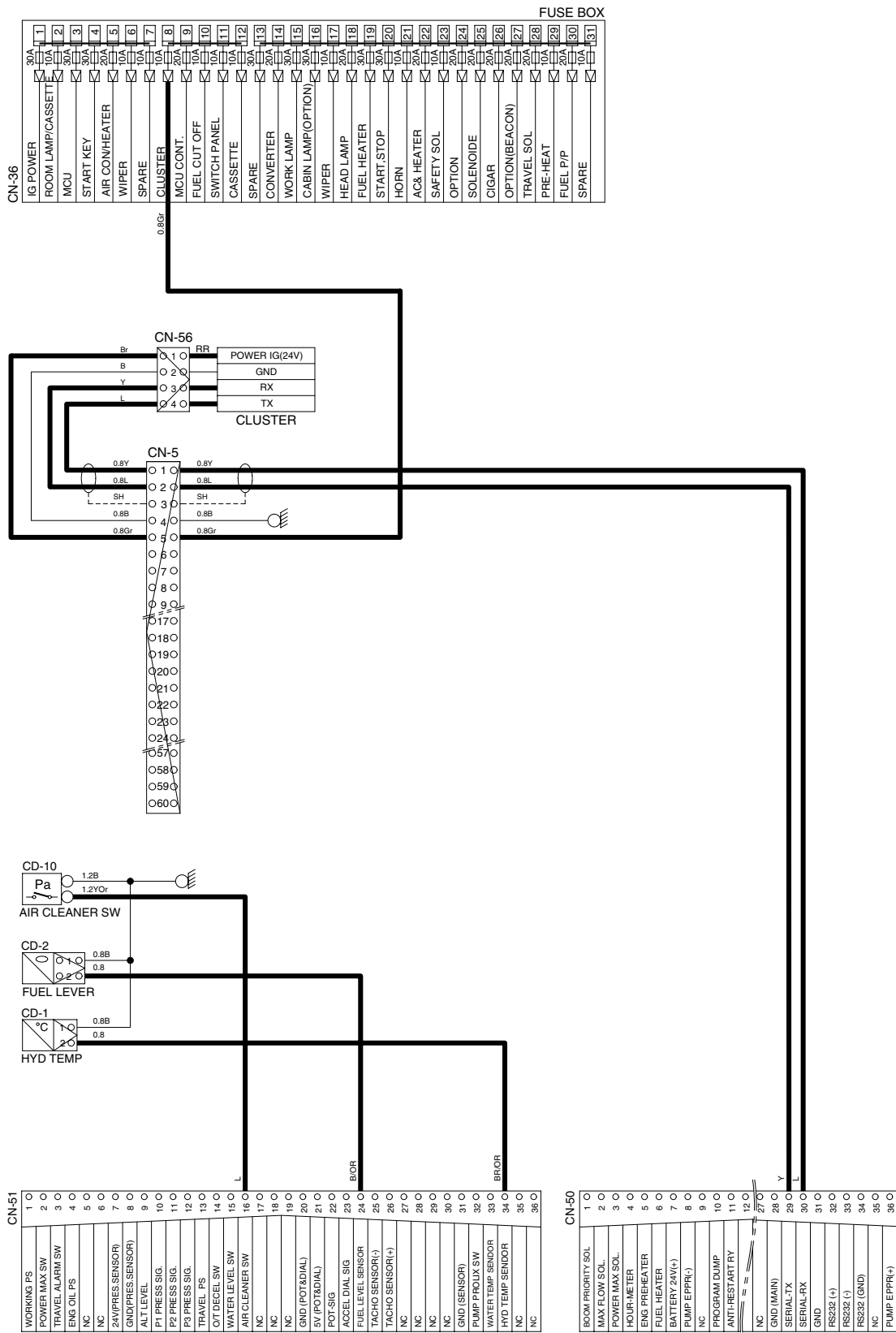

# ELECTRIC CIRCUIT FOR HYDRAULIC (CLUSTER TYPE 1)

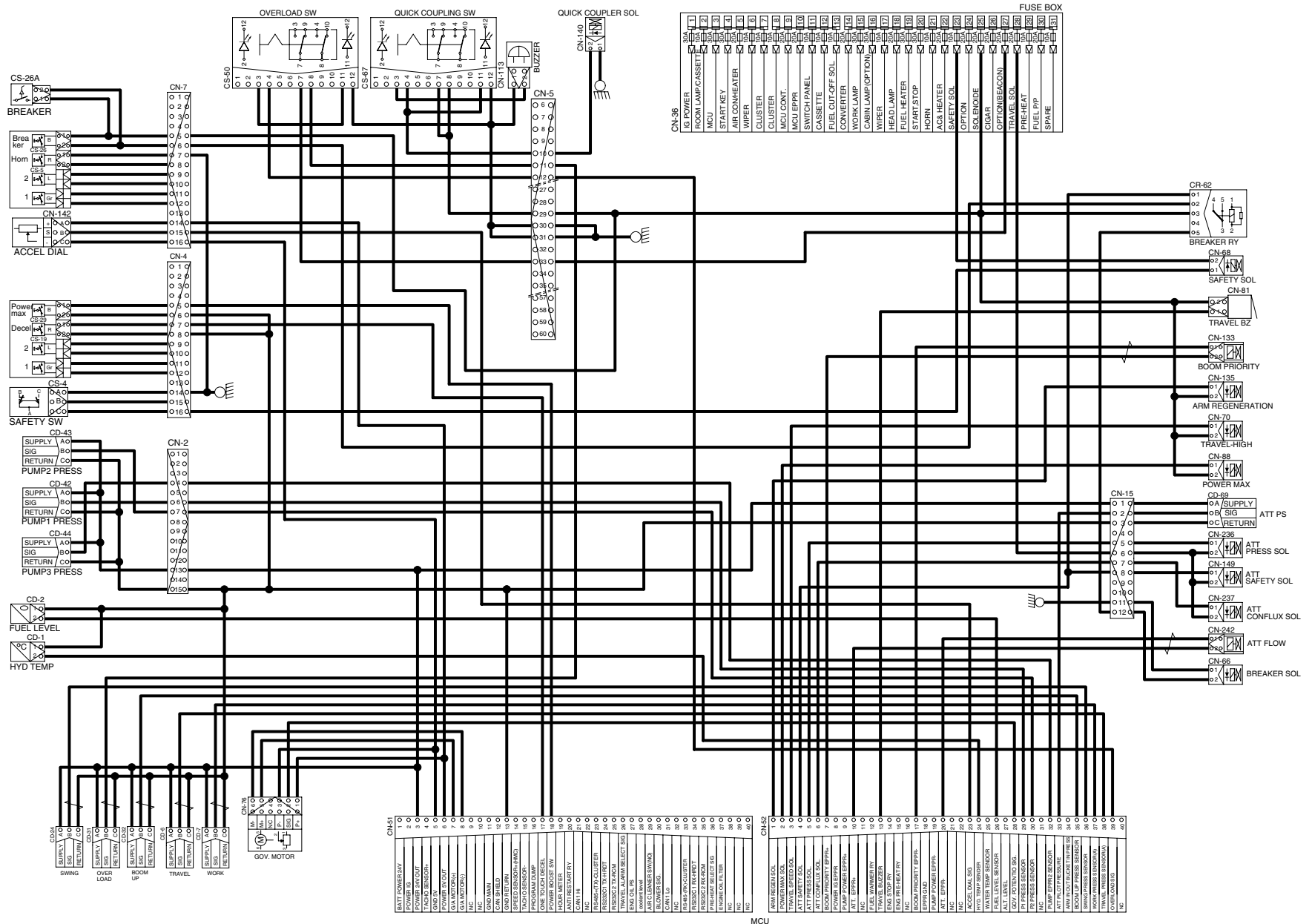

MCU

# ELECTRIC CIRCUIT FOR HYDRAULIC (CLUSTER TYPE 2)

