

GROUP 4 SINGLE OPERATION

1. BOOM UP OPERATION

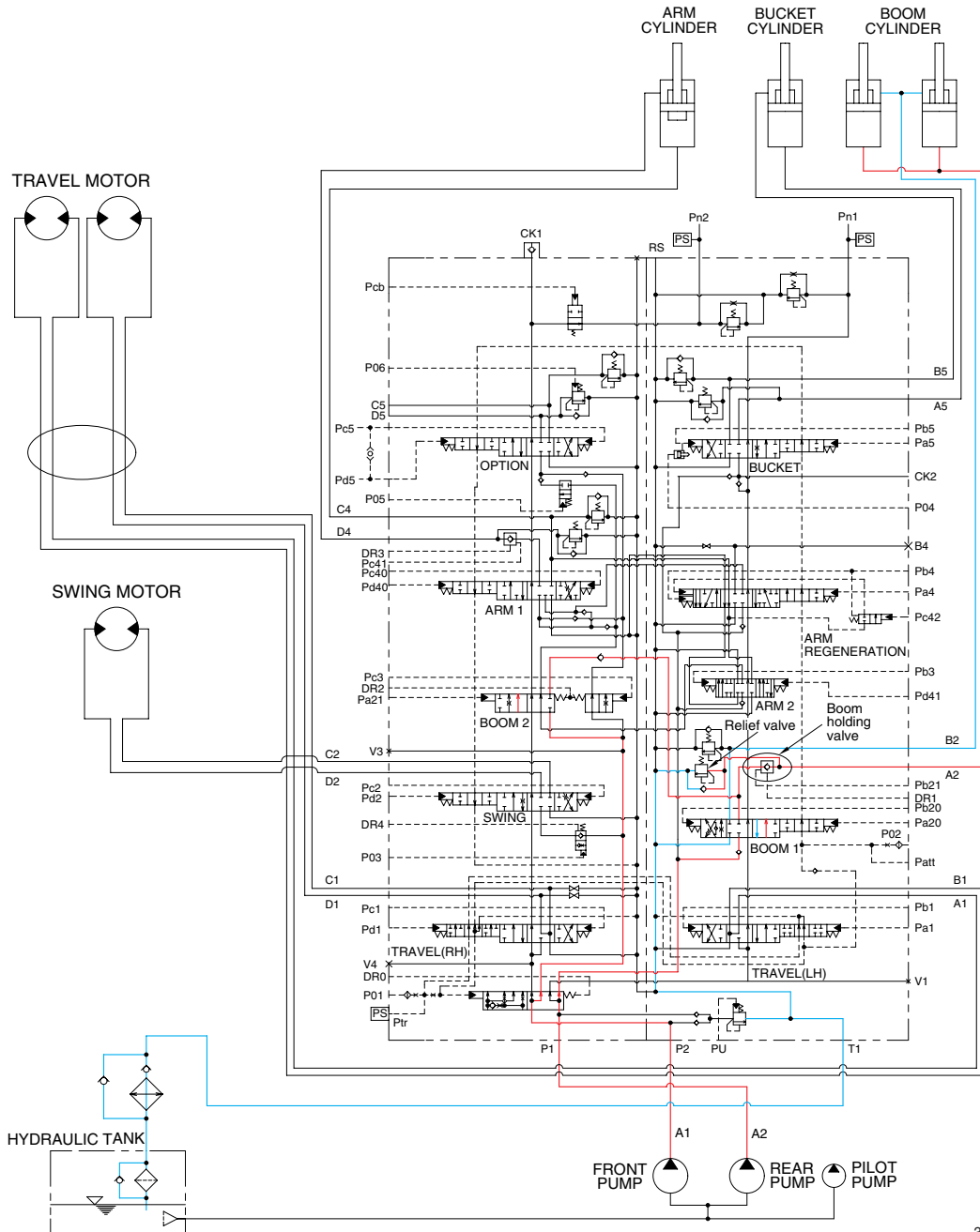

3009A3HC10

When the RH control lever is pulled back, the boom spools in the main control valve are moved to the up position by the pilot oil pressure from the remote control valve.

The oil from the A1 and A2 pump flows into the main control valve and then goes to the large chamber of boom cylinders.

At the same time, the oil from the small chamber of boom cylinders returns to the hydraulic oil tank through the boom spool in the main control valve. When this happens, the boom goes up.

The excessive pressure in the boom cylinder bottom end circuit is prevented by relief valve.

When the boom is up and the control lever is returned to neutral position, the circuit for the holding pressure at the bottom end of the boom cylinder is closed by the boom holding valve.

This prevents the hydraulic drift of boom cylinder.

2. BOOM DOWN OPERATION

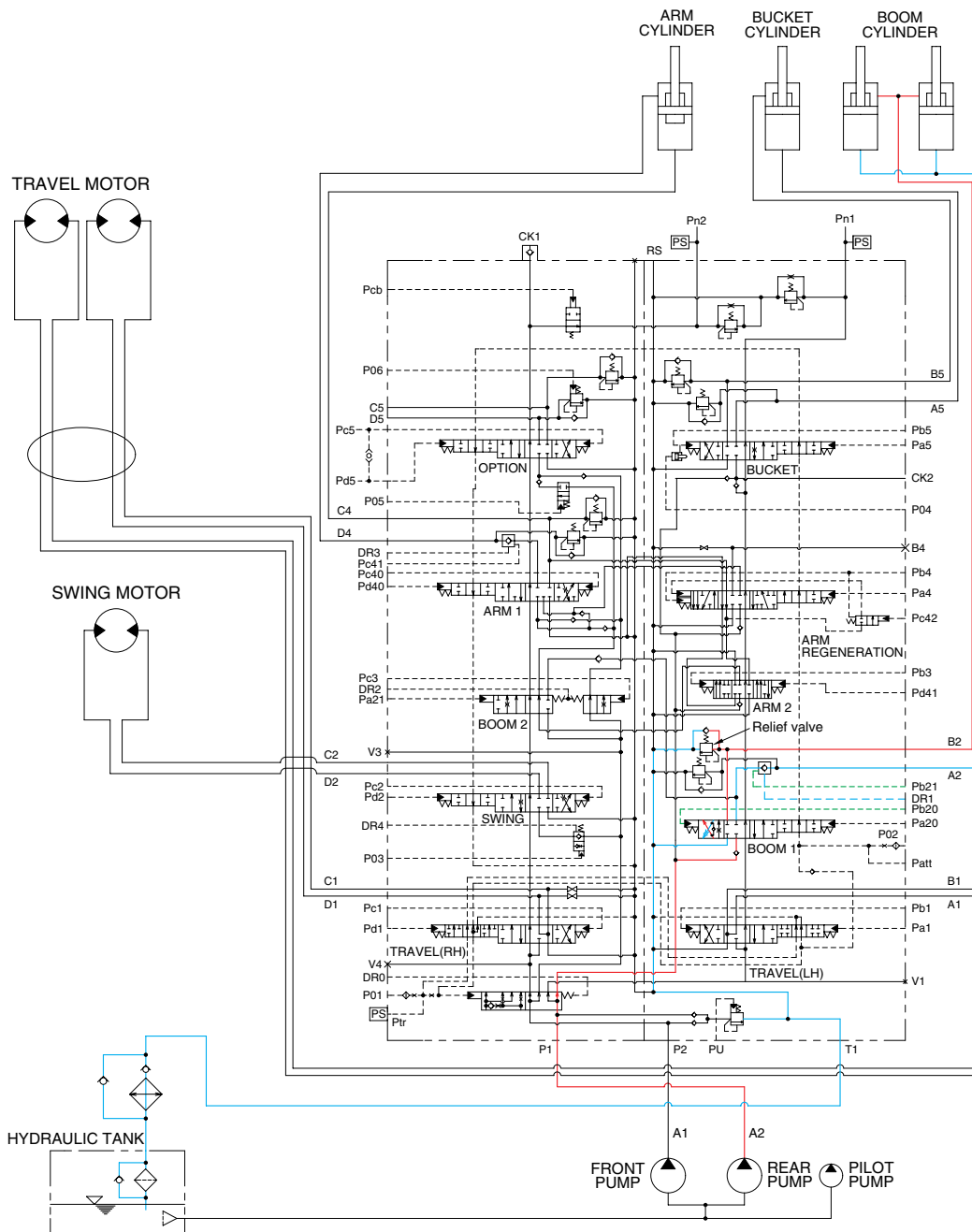

3009A3HC11

When the RH control lever is pushed forward, the boom spools in the main control valve are moved to the down position by the pilot oil pressure from the remote control valve.

The oil from the A2 pump flows into the main control valve and then goes to the small chamber of boom cylinders. At the same time, the oil from the large chamber of boom cylinders returns to the hydraulic tank through the boom spool in the main control valve.

When the down speed of boom is faster, the oil returned from the large chamber of boom cylinder combines with the oil from the rear pump, and flows into the small chamber of the boom cylinder.

This prevents cylinder cavitation by the negative pressure when the rear pump flow can not match the boom down speed. And the excessive pressure in the boom cylinder rod end circuit is prevented by the relief valve.

3. ARM IN OPERATION

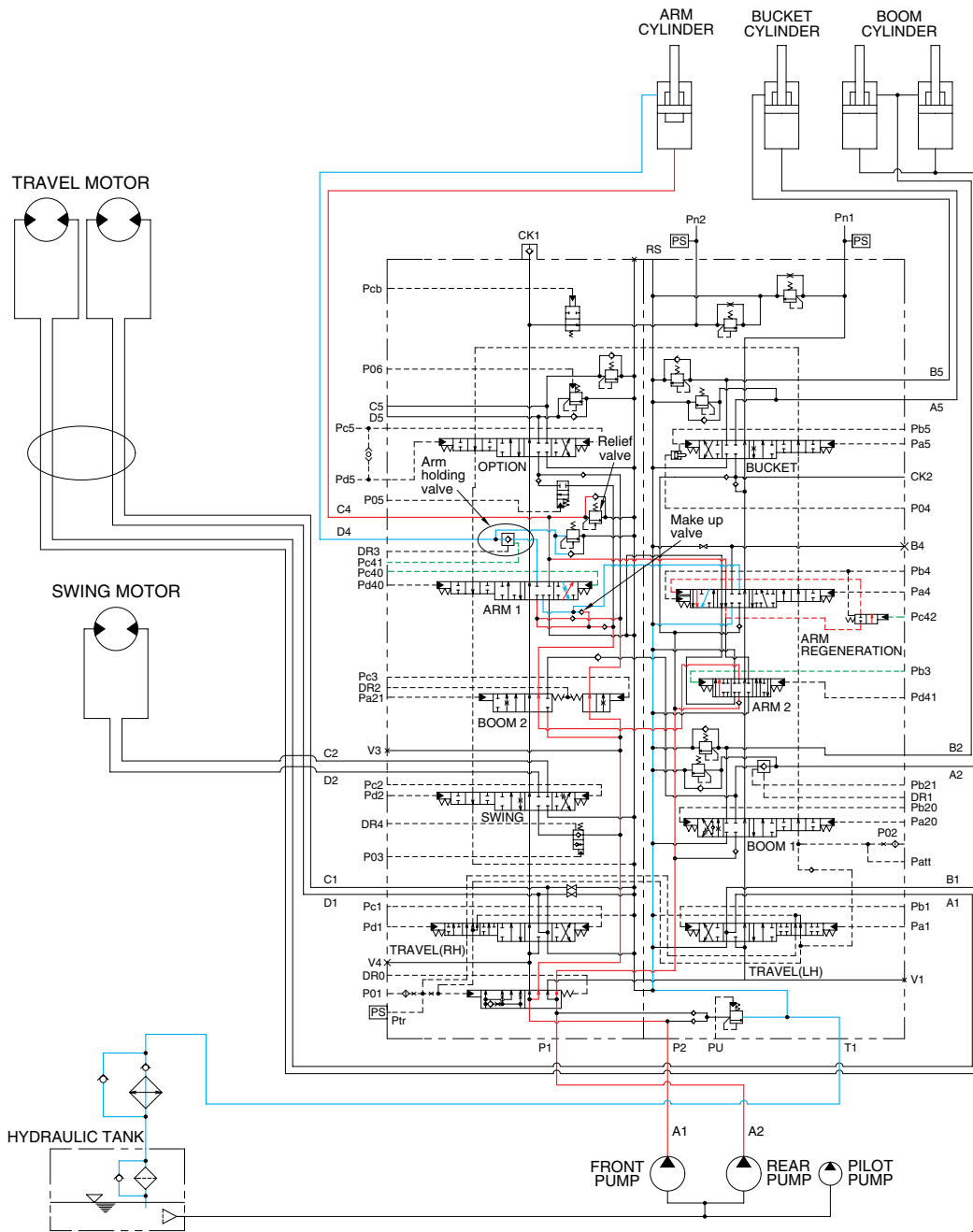

3009A3HC12

When the LH control lever is pulled back, the arm spools in the main control valve are moved to the roll in position by the pilot oil pressure from the remote control valve.

The oil from the A1 and A2 pump flows into the main control valve and then goes to the large chamber of arm cylinder.

At the same time, the oil from the small chamber of arm cylinder returns to the hydraulic oil tank through the arm spool in the main control valve. When this happens, the arm rolls in.

When the roll in speed of arm is faster, the oil returned from the small chamber of arm cylinder combines with the oil from both pump, and flows into the large chamber of the arm cylinder by a make up valve.

The excessive pressure in the arm cylinder bottom end circuit is prevented by relief valve.

Refer to page 3-11 for the arm regeneration.

4. ARM OUT OPERATION

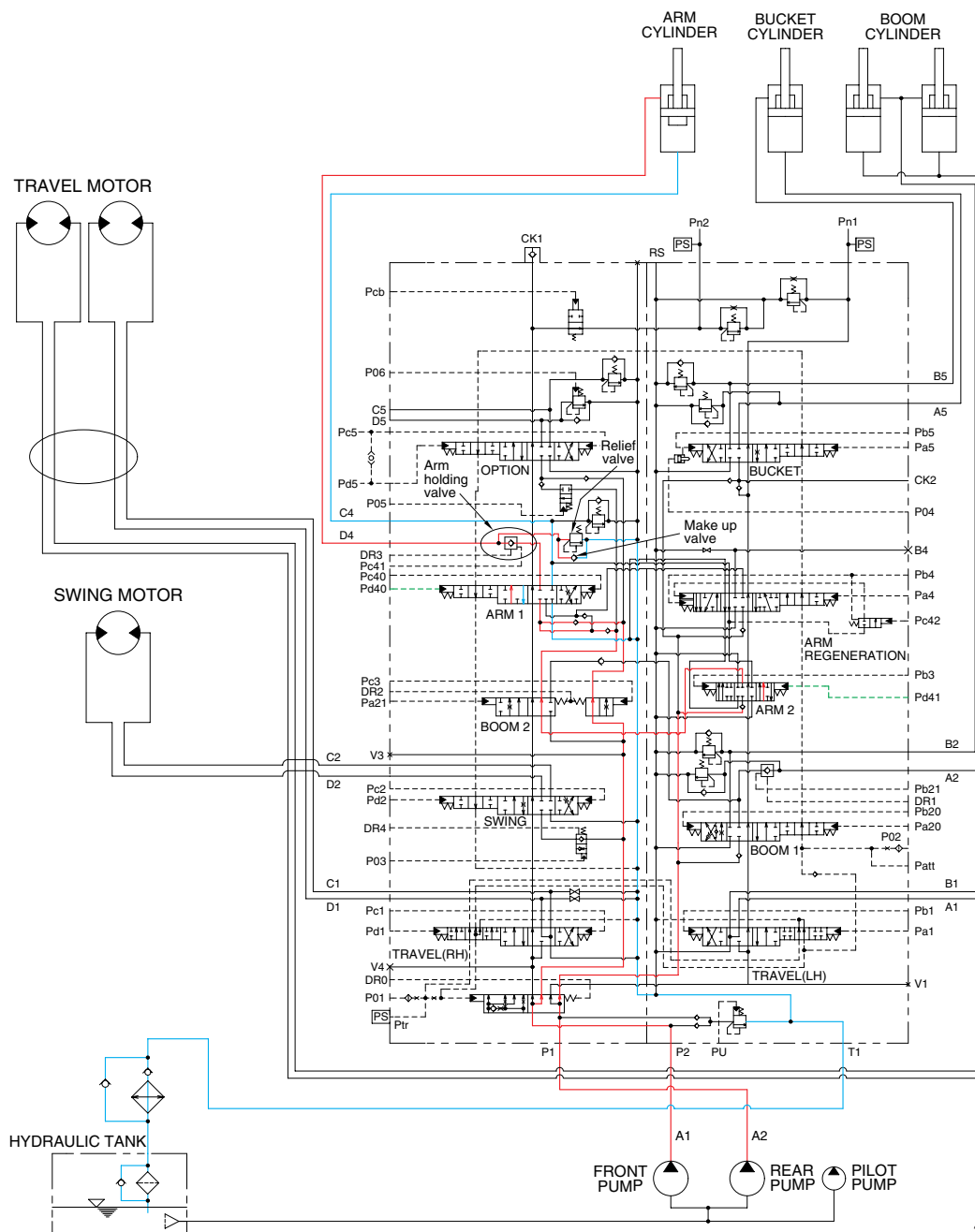

3009A3HC13

When the LH control lever is pushed forward, the arm spools in the main control valve are moved to the roll out position by the pilot oil pressure from the remote control valve.

The oil from the A1 and A2 pump flows into the main control valve and then goes to the small chamber of arm cylinder. At the same time, the oil from the large chamber of arm cylinder returns to the hydraulic oil tank through the arm spool in the main control valve.

When this happens, the arm roll out. When the roll out speed of arm is faster, the oil returned from the large chamber of arm cylinder combines with the oil from both pump, and flows into the small chamber of the arm cylinder by a make up valve.

The excessive pressure in the arm cylinder rod end circuit is prevented by relief valve.

When the arm is rolled out and the control lever is returned to neutral position, the circuit for the holding pressure at the rod end of the arm cylinder is closed by the arm holding valve.

This prevents the hydraulic drift of arm cylinder.

5. BUCKET IN OPERATION

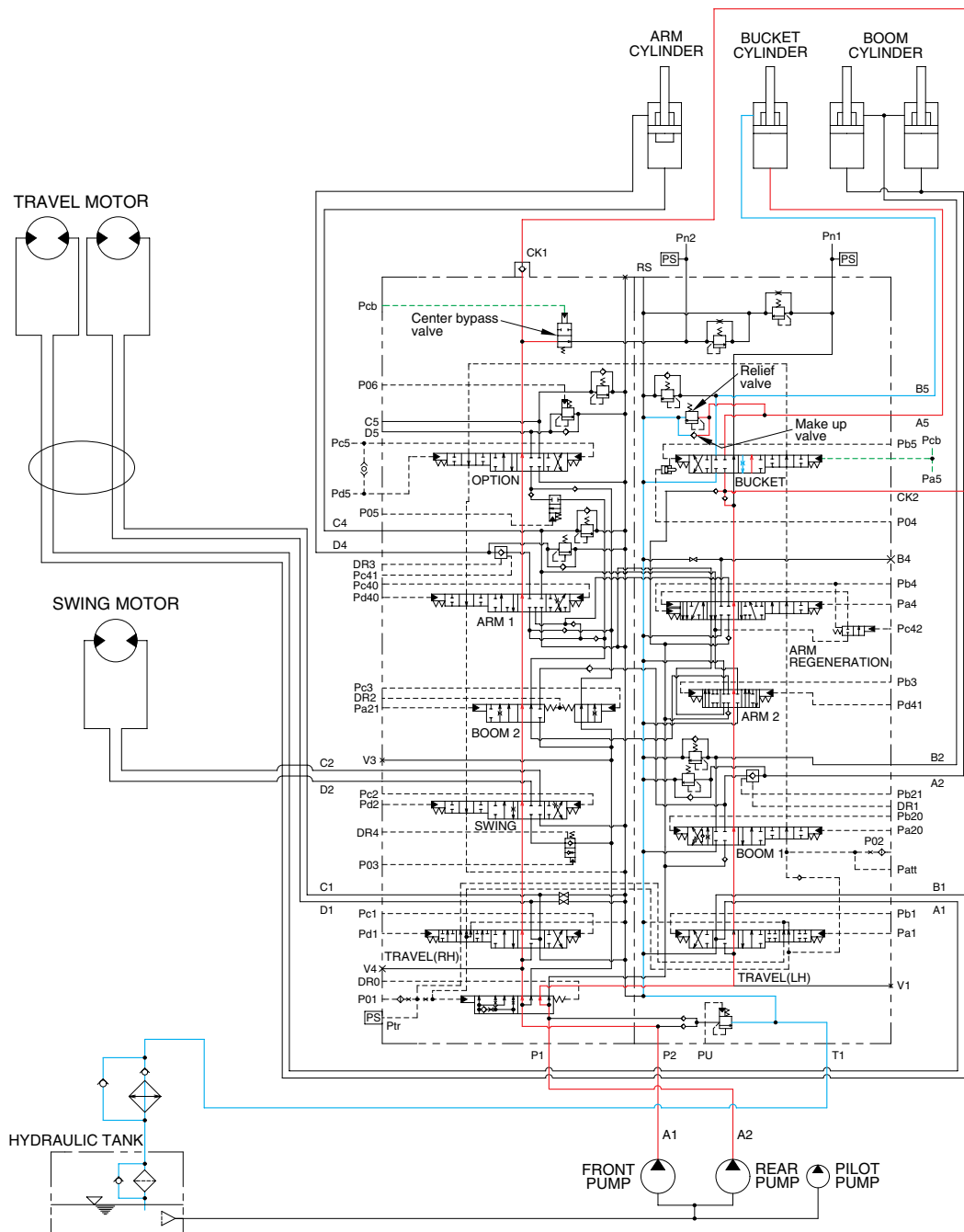

3009A3HC14

When the RH control lever is manually placed in the bucket roll in position. Then the oil flows from pilot pump through the pilot valve to bucket section of the main control valve. Here the spool position is moved to bucket roll in position.

The center bypass valve is change over by the pilot pressure (Pcb) and then the oil from A2 pump is joint to the flow of A1 pump via check 1 and external piping.

The oil flows from both pump through rod end of the cylinder through the bucket section returned to the hydraulic tank.

The cavitation which will happen to the bottom of the bucket cylinder is prevented by a make up valve, on other hand. The excessive pressure is also prevented by an overload relief valve in the main control valve.

6. BUCKET OUT OPERATION

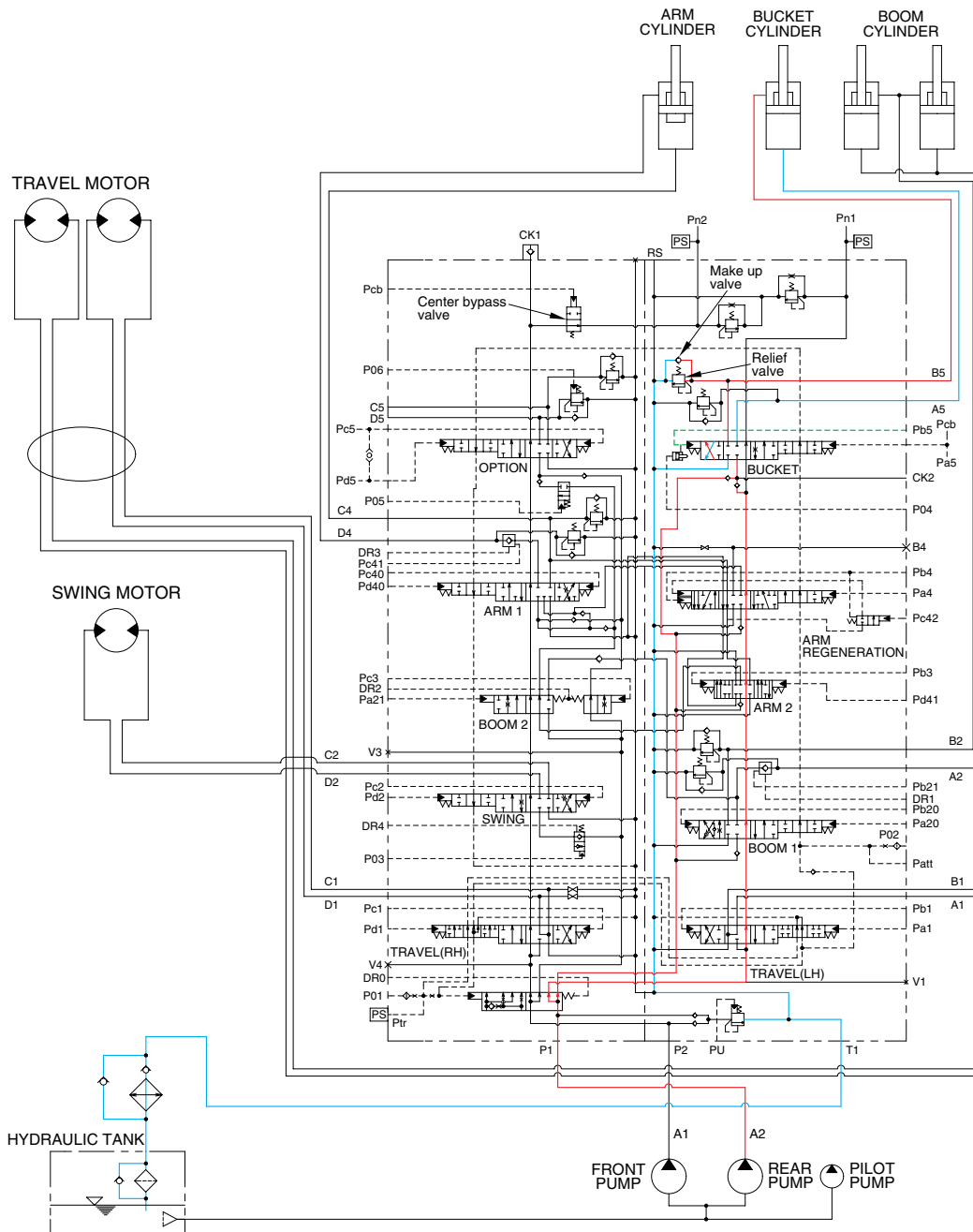

3009A3HC15

When the RH control lever is manually placed in the bucket roll out position. Then the oil flows from pilot pump through the pilot valve to bucket section of the main control valve. Here the spool position is moved to bucket roll out position.

The oil flows from A2 pump through bucket section of main control valve to the rod end of the bucket cylinder, and to roll out bucket.

The return oil flows from the bottom end of the cylinder through the bucket section returned to the hydraulic tank.

The cavitation which will happen to the rod of the bucket cylinder is prevented by a make up valve, on other hand. The excessive pressure is also prevented by an overload relief valve in the main control valve.

7. SWING OPERATION

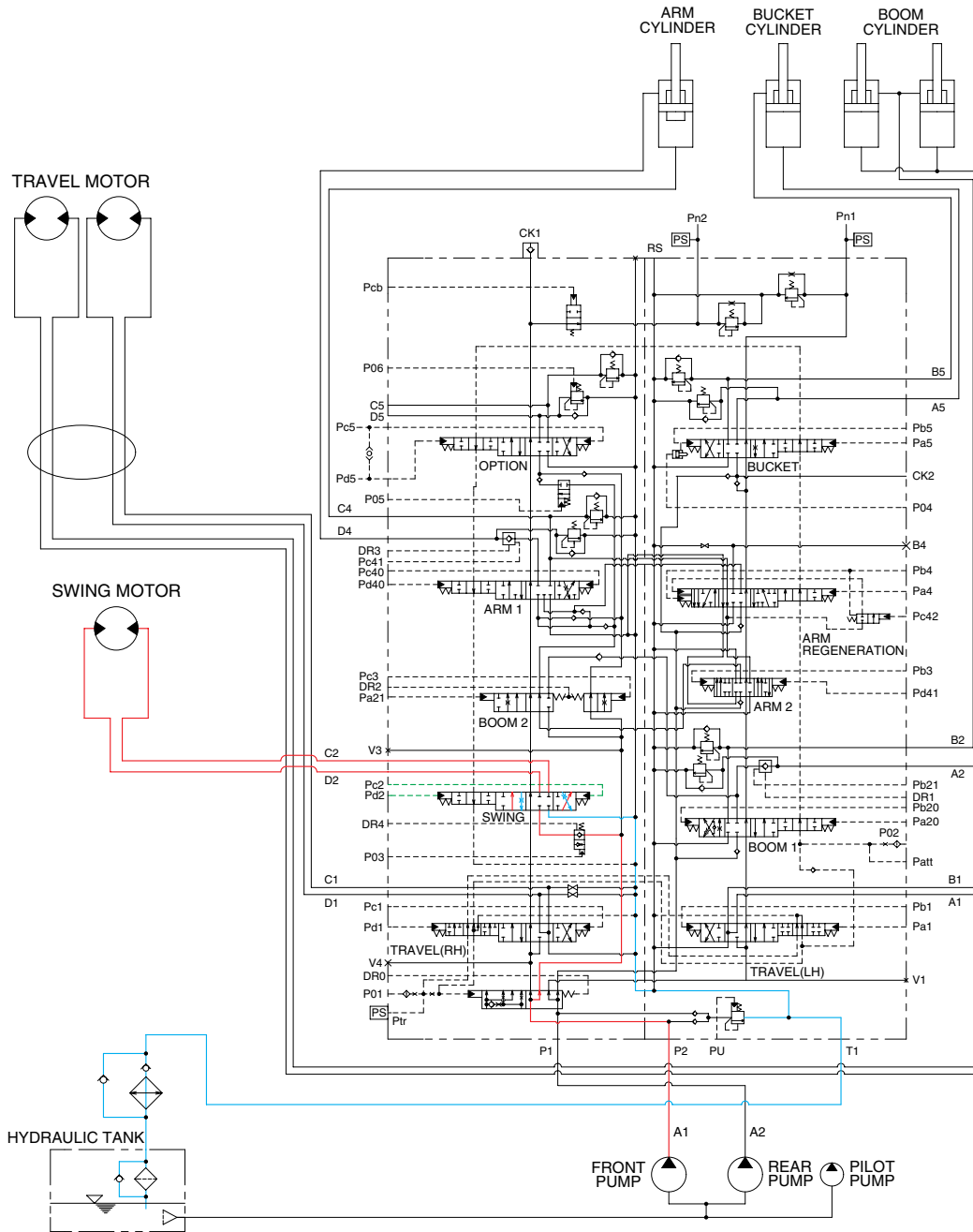

3009A3HC16

When the LH control lever is manually placed in the left (right) swing position. Then the oil flows from A1 pump through the swing section of the main control valve to swing motor to left (right) swing the superstructure. The return oil flows from swing motor through the swing section of the main control valve returned to the tank.

When the control lever placed in the neutral position, the pressure of the pilot oil passage down.

Then the brake release valve returned to the neutral position and the oil is returned from the brake piston to the tank. And the brake is set to "ON". The swing parking brake, make up valve and the overload relief valve are provide in the swing motors. The cavitation which will happen to the swing motor is prevented by the make up valve in the swing motor itself.

SWING CIRCUIT OPERATION

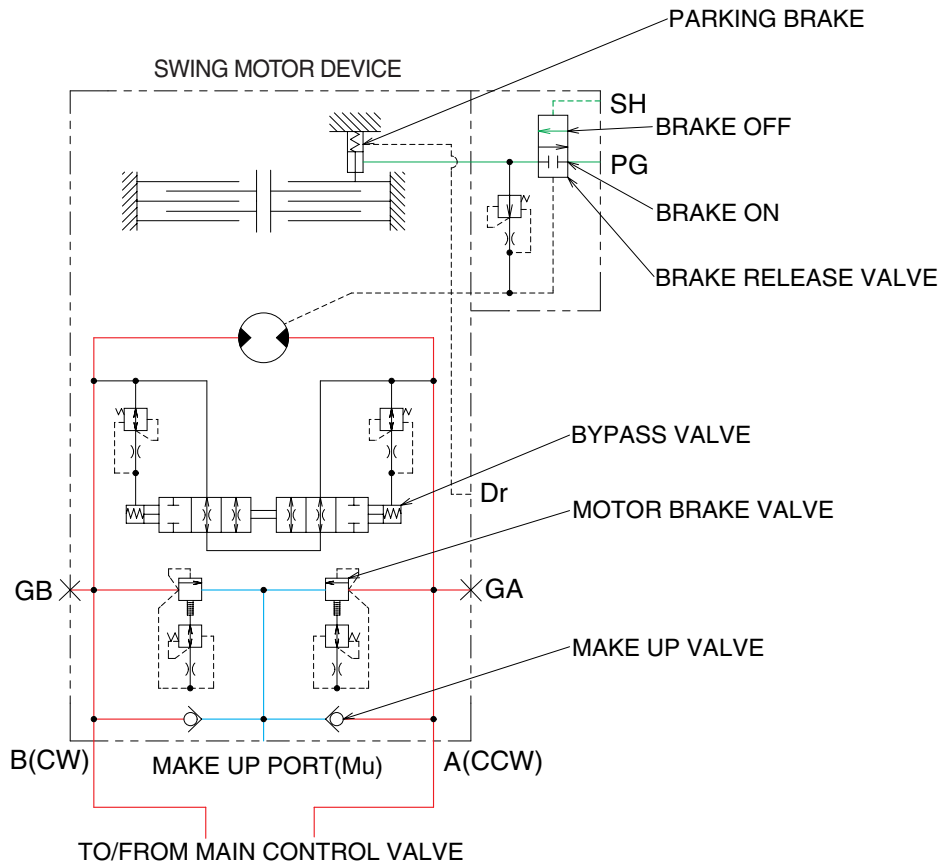

3009SH3HC17

1) MOTOR BRAKE VALVE

Motor brake valve for the swing motor limits to cushion the starting and stopping pressure of swing operation.

2) MAKE UP VALVE

The make up valves prevent cavitation by supplying return oil to the vacuum side of the motor.

3) PARKING BRAKE

In case that the parking, of the machine at slope is required during operation, there is the danger of involuntary swing caused by the self weight of the machine. The brake is connected to prevent this involuntary swing.

PARKING BRAKE "OFF" OPERATION

The parking brake is released by the pilot pressure oil from the pilot pump.

When the left control lever placed in the swing position, the pilot pressure at the shuttle valve is transferred to the brake release valve and the brake release valve is change over. Then the pilot pressure lift the brake piston and release the parking brake.

PARKING BRAKE "ON" OPERATION

When the control lever placed in the neutral position, the pressure of the pilot oil passage down.

Then the brake release valve returned to the neutral position and the oil is returned from the brake piston to the tank. And the brake is set to 'ON'.

4) BYPASS VALVE

This bypass valve absorbs shocks produced as swing motion stops and reduced oscillation cause by swing motion.

8. TRAVEL FORWARD AND REVERSE OPERATION

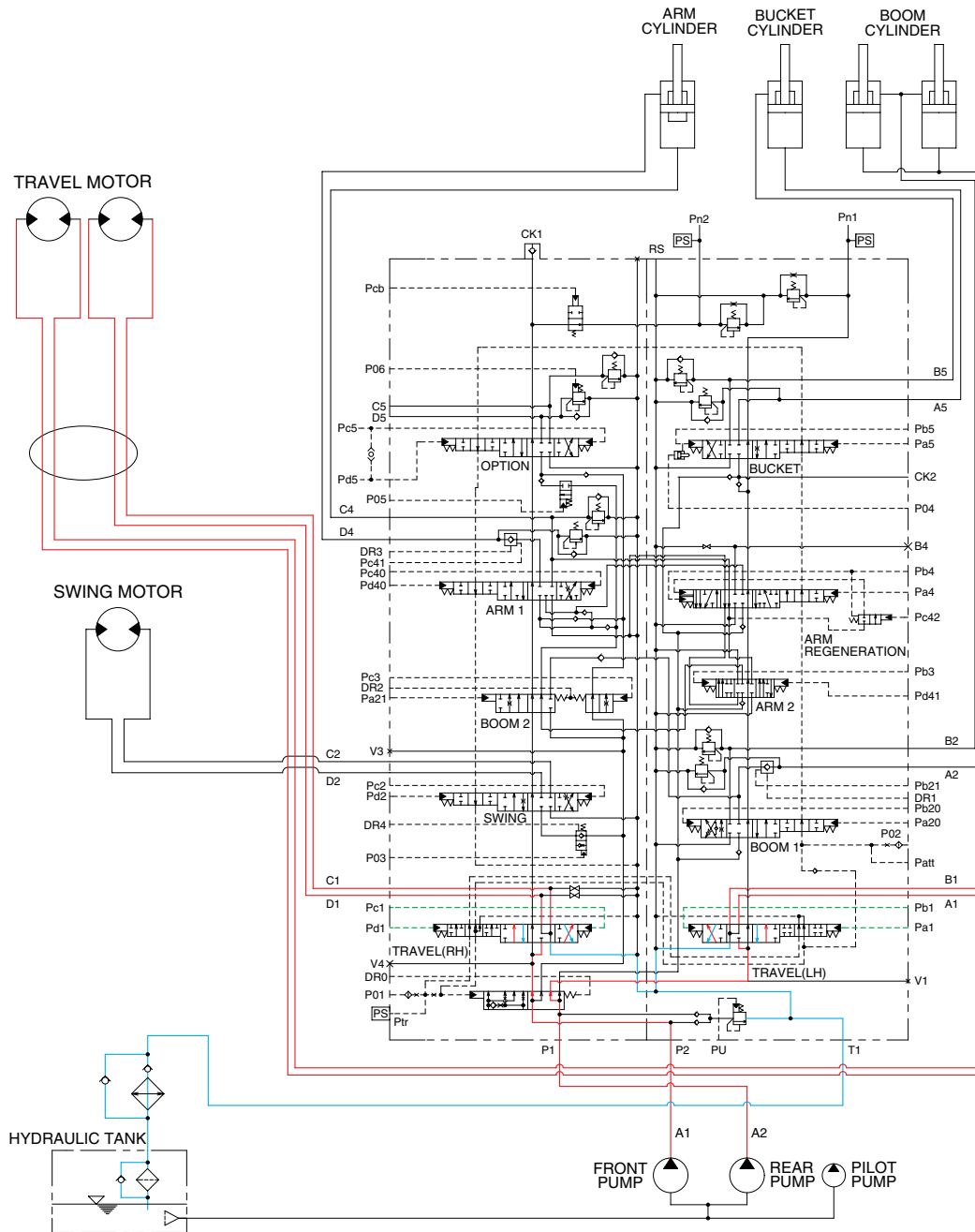

3009A3HC18

When the right and left travel levers are manually placed to the forward or reverse position, the oil flows from pilot pump through the pilot valve to travel sections of the main control valve.

Here, spool position is moved to forward and reverse position. The oil flows from A2 pump through the travel (RH) section of the main control valve and turning joint to the right travel motor and oil flows from A1 pump through the travel (LH) section of the main control valve and turning joint to the left travel motor and move the machine forward or reverse.

The return oil flows from both travel motor through the turning joint and travel (RH, LH) sections returned to the tank.

TRAVEL CIRCUIT OPERATION

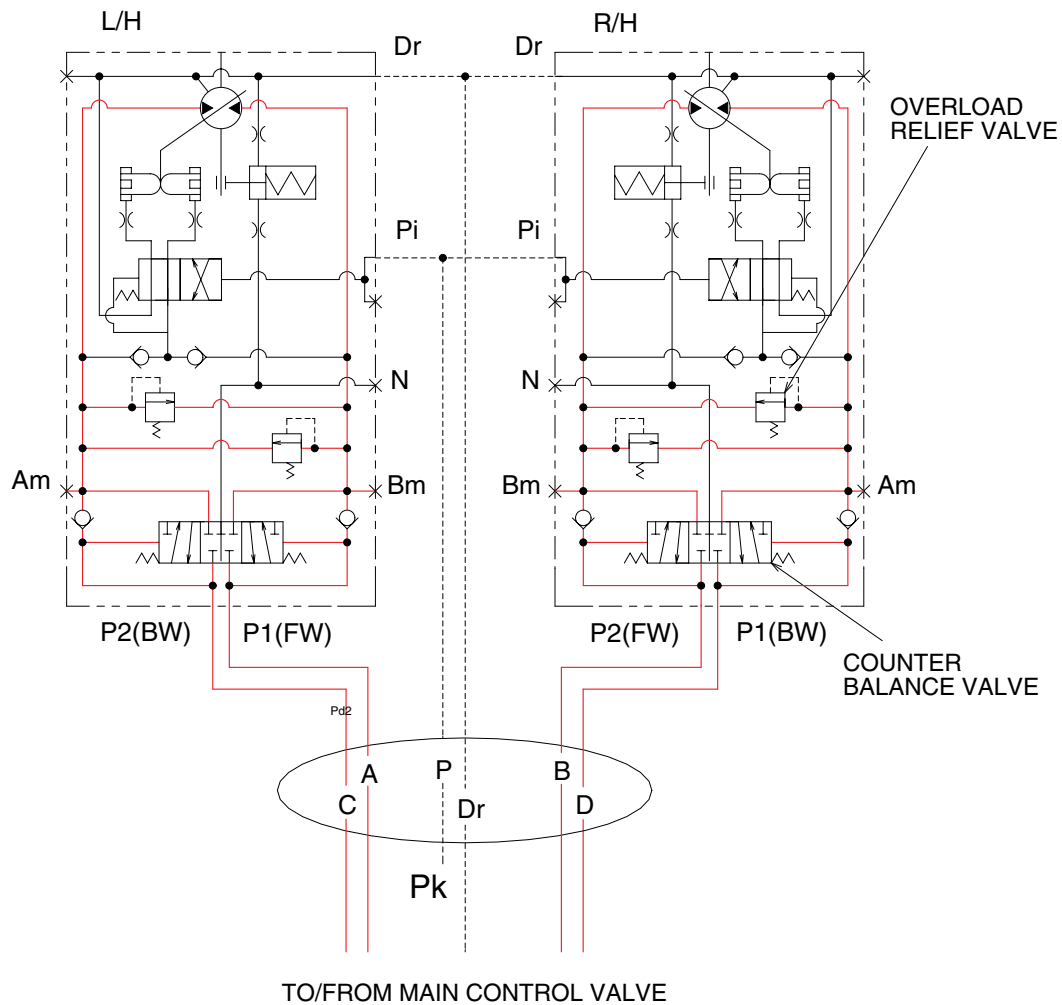

3009SH3HC19

Valves are provided on travel motors to offer the following functions.

1) COUNTER BALANCE VALVE

When stopping the motor of slope descending, this valve to prevent the motor over run.

2) OVERLOAD RELIEF VALVE

Relief valve limit the circuit pressure below 380 kgf/cm^2 to prevent high pressure generated at a time of stopping the machine. Stopping the motor, this valve sucks the oil from lower pressure passage for preventing the negative pressure and the cavitation of the motor.