

# GROUP 4 HYDRAULIC SYSTEM

## HYDRAULIC COMPONENTS MOUNTING 1

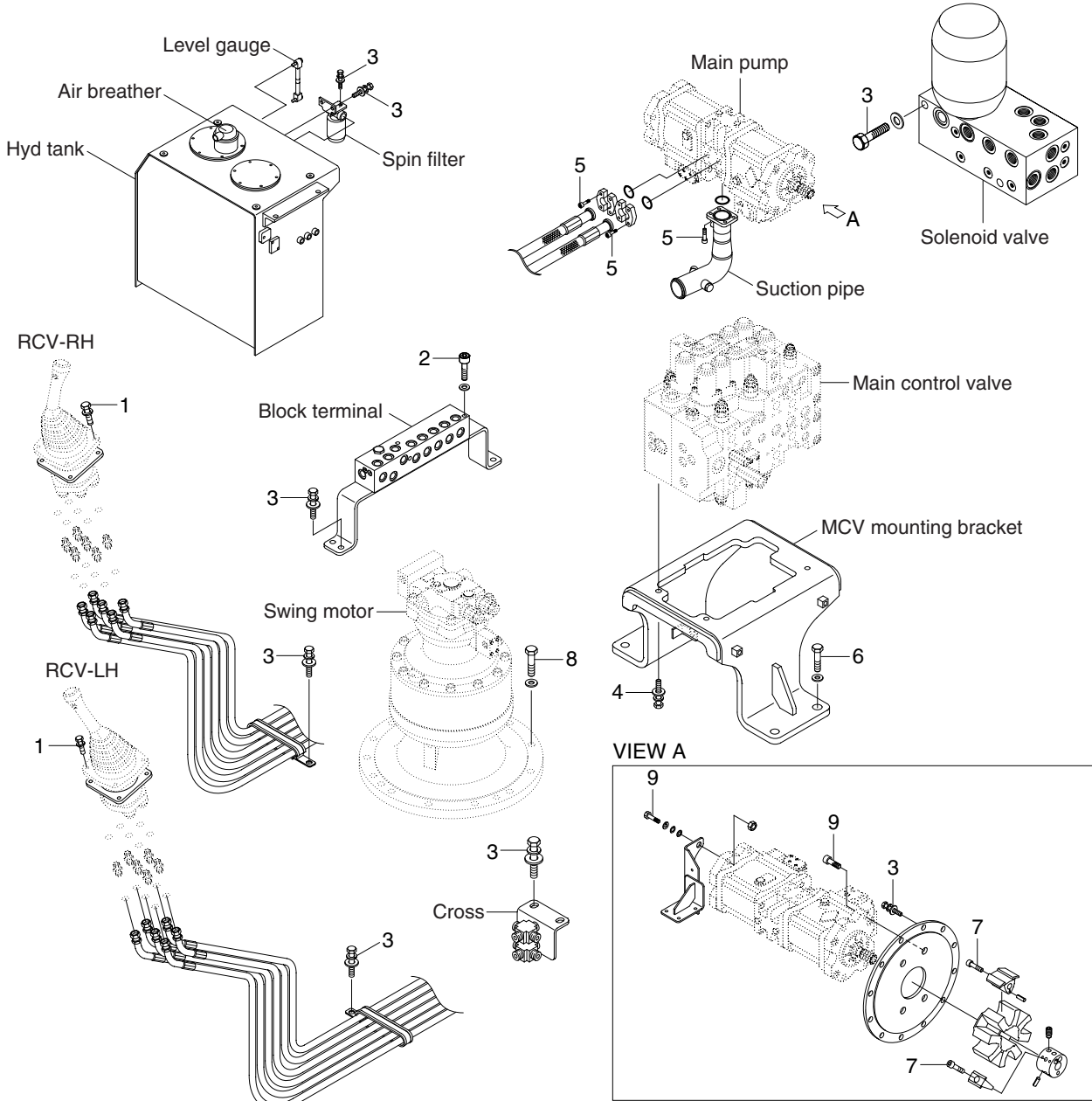

3009A9CM05

### · Tightening torque

Item	Size	kgf · m	lbf · ft
1	M 6×1.0	1.05±0.2	7.6±1.45
2	M 8×1.25	4.05±0.8	29.3±5.8
3	M10×1.5	6.9±1.4	49.9±10.1
4	M12×1.75	12.3±1.3	88.9±9.4
5	M12×1.75	12.8±3.0	92.5±21.6

Item	Size	kgf · m	lbf · ft
6	M20×2.5	46±5.1	333±36.9
7	M20×2.5	46.5±2.5	336±18.1
8	M20×2.5	58.4±6.4	422±46.2
9	M20×2.5	57.9±8.7	419±62.9
-	-	-	-

# HYDRAULIC COMPONENTS MOUNTING 2

Double acting attachment piping

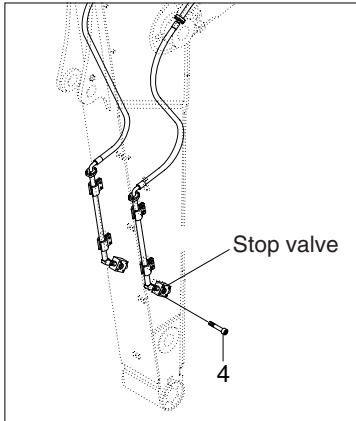

Travel motor(RH)

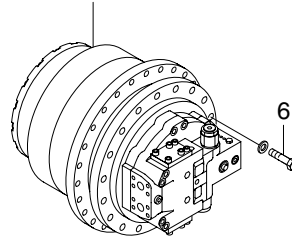

Travel motor type 2

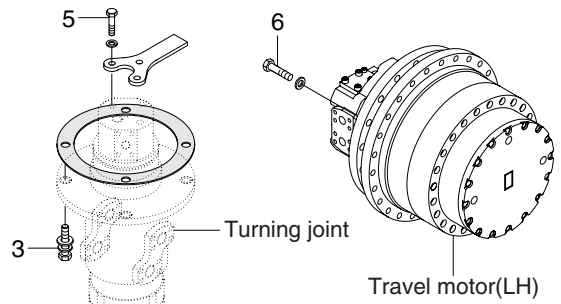
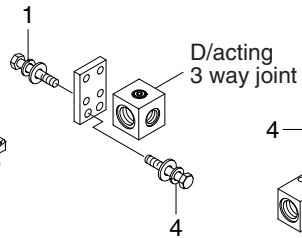
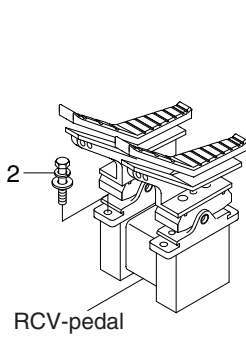
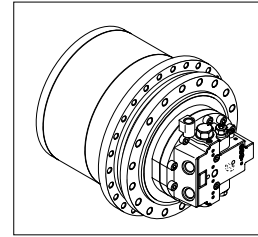

D/acting single pedal

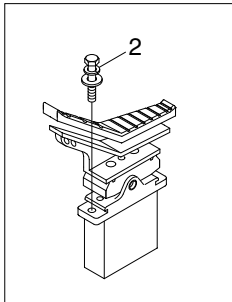

Boom safety lock system

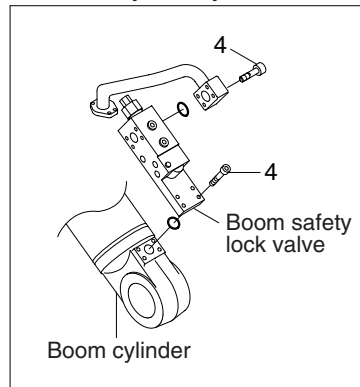

Arm safety lock system

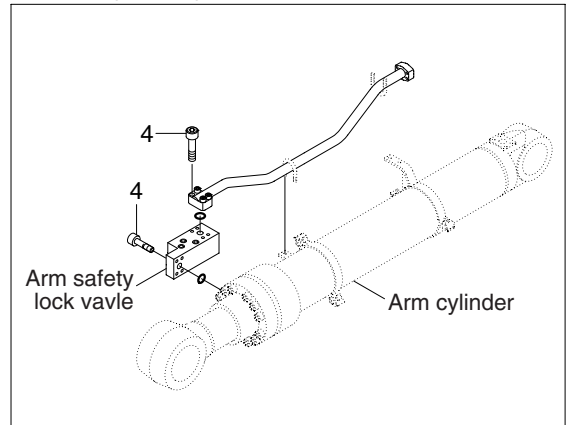

3009A9CM06

· Tightening torque

Item	Size	kgf · m	lbf · ft
1	M 8×1.25	4.05±0.8	29.3±5.8
2	M10×1.5	6.9±1.4	49.9±10.1
3	M12×1.75	12.3±1.3	88.9±9.4

Item	Size	kgf · m	lbf · ft
4	M12×1.75	12.8±3.0	92.6±21.7
5	M14×2.0	19.6±2.9	142±20.9
6	M24×3.0	84±8.0	608±57.8

## HYDRAULIC COMPONENTS MOUNTING 3

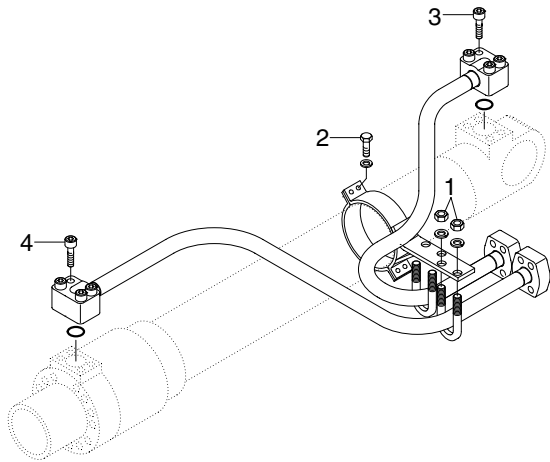

BOOM CYLINDER

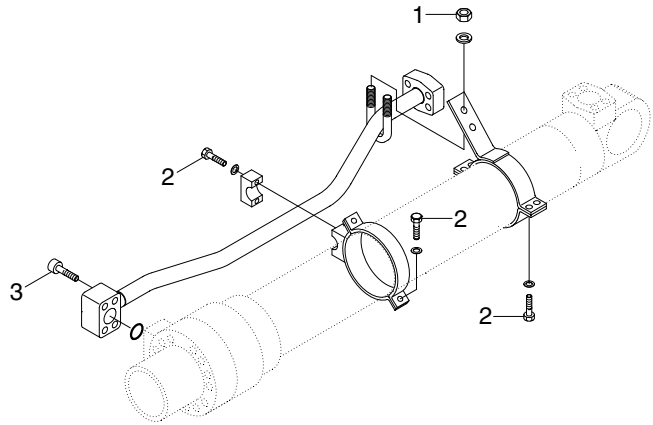

ARM CYLINDER

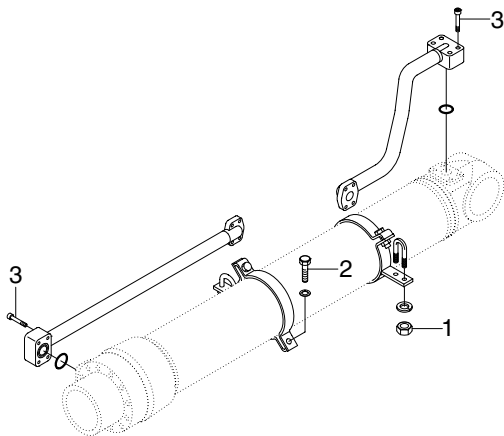

BUCKET CYLINDER

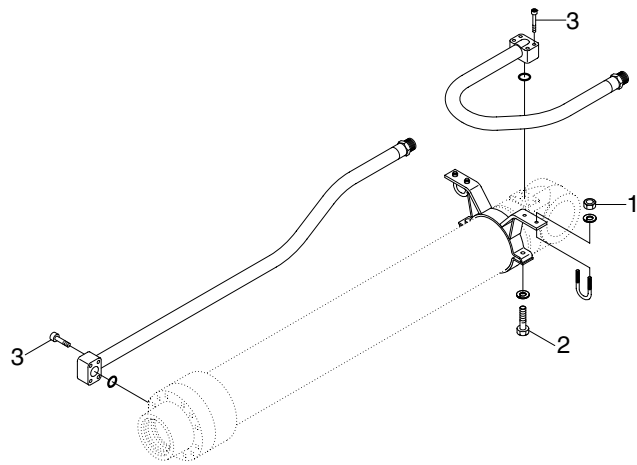

BUCKET CYLINDER (LONG REACH)

3009S9CM07

### · Tightening torque

Item	Size	kgf · m	lbf · ft
1	M10×1.5	3.2±0.3	23.1±2.2
2	M 8×1.25	2.7±0.3	19.5±2.2
3	M12×1.75	5.5±0.6	39.8±4.3
4	M12×1.75	9.4±1.0	68.0±7.2

Item	Size	kgf · m	lbf · ft
5	M16×2.0	23±2.0	166±14.5
6	M18×2.5	32±3.0	232±21.7
7	M20×2.5	46±5.0	333±36.2