

GROUP 5 COMBINED OPERATION

1. OUTLINE

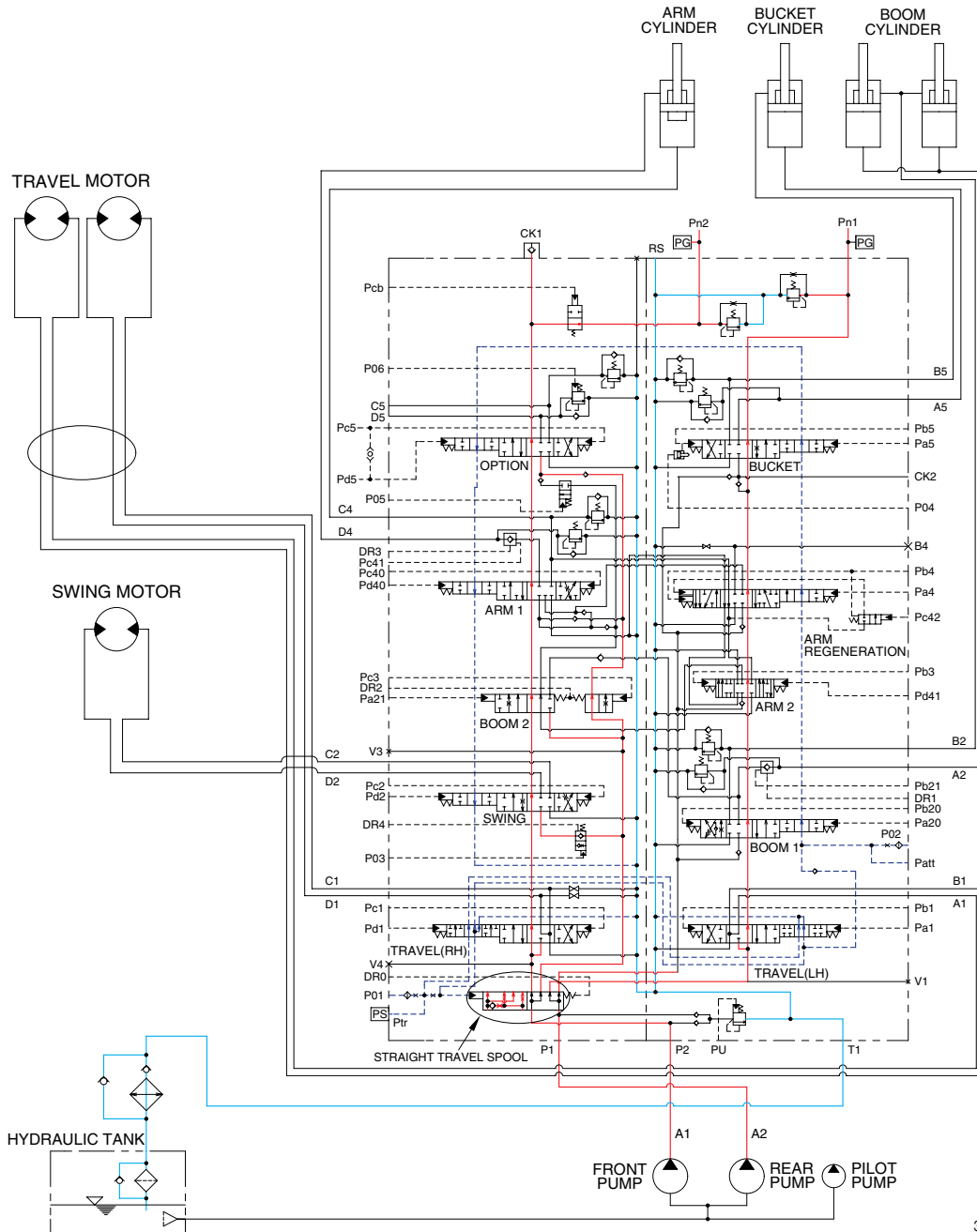

3009A3HC20

The oil from the A1 and A2 pump flows through the neutral oil passage, bypass oil passage and confluence oil passage in the main control valve. Then the oil goes to each actuator and operates them. Check valves and orifices are located on these oil passage in the main control valve. These control the oil from the main pumps so as to correspond to the operation of each actuator and smooth the combined operation.

STRAIGHT TRAVEL SPOOL

This straight travel spool is provided in the main control valve.

If any actuator is operated when traveling, the straight travel spool is pushed to the right by the pilot oil pressure from the pilot pump.

Consequently, the left and right travel oil supply passage are connected, and equivalent amount of oil flows into the left and right travel motors. This keeps the straight travel.

2. COMBINED SWING AND BOOM UP OPERATION

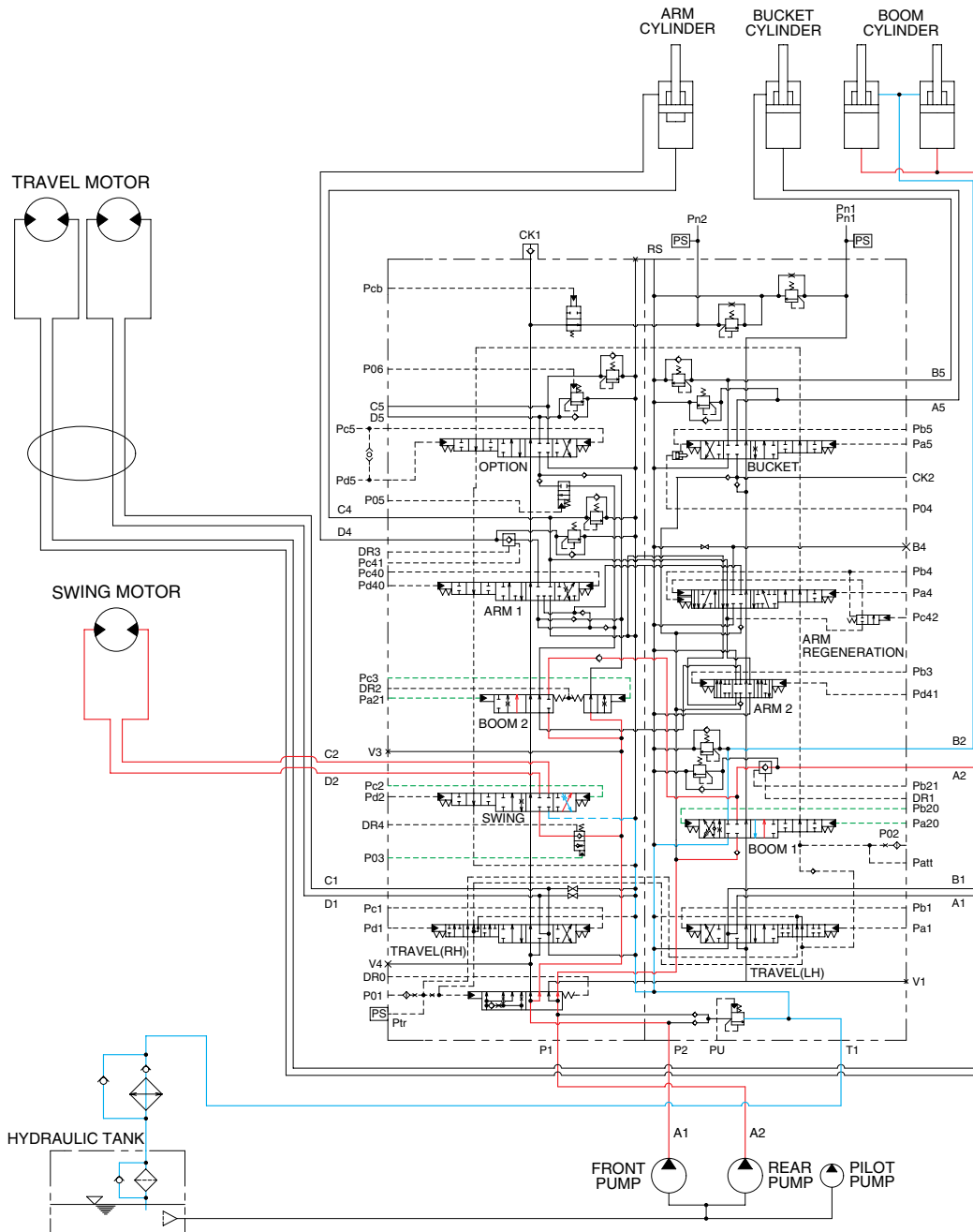

3009A3HC21

When the swing and boom up functions are operated, simultaneously the swing spool and boom spools changed. The oil flows from the A2 pump through boom 1 section of the main control valve to boom cylinders and the boom functions.

The oil flows from A1 pump flow into swing motor through swing spool and the boom cylinder through boom 2 spool.

The upper structure swing and the boom is up.

Refer to page 3-8 for the boom priority system.

3. COMBINED SWING AND ARM OPERATION

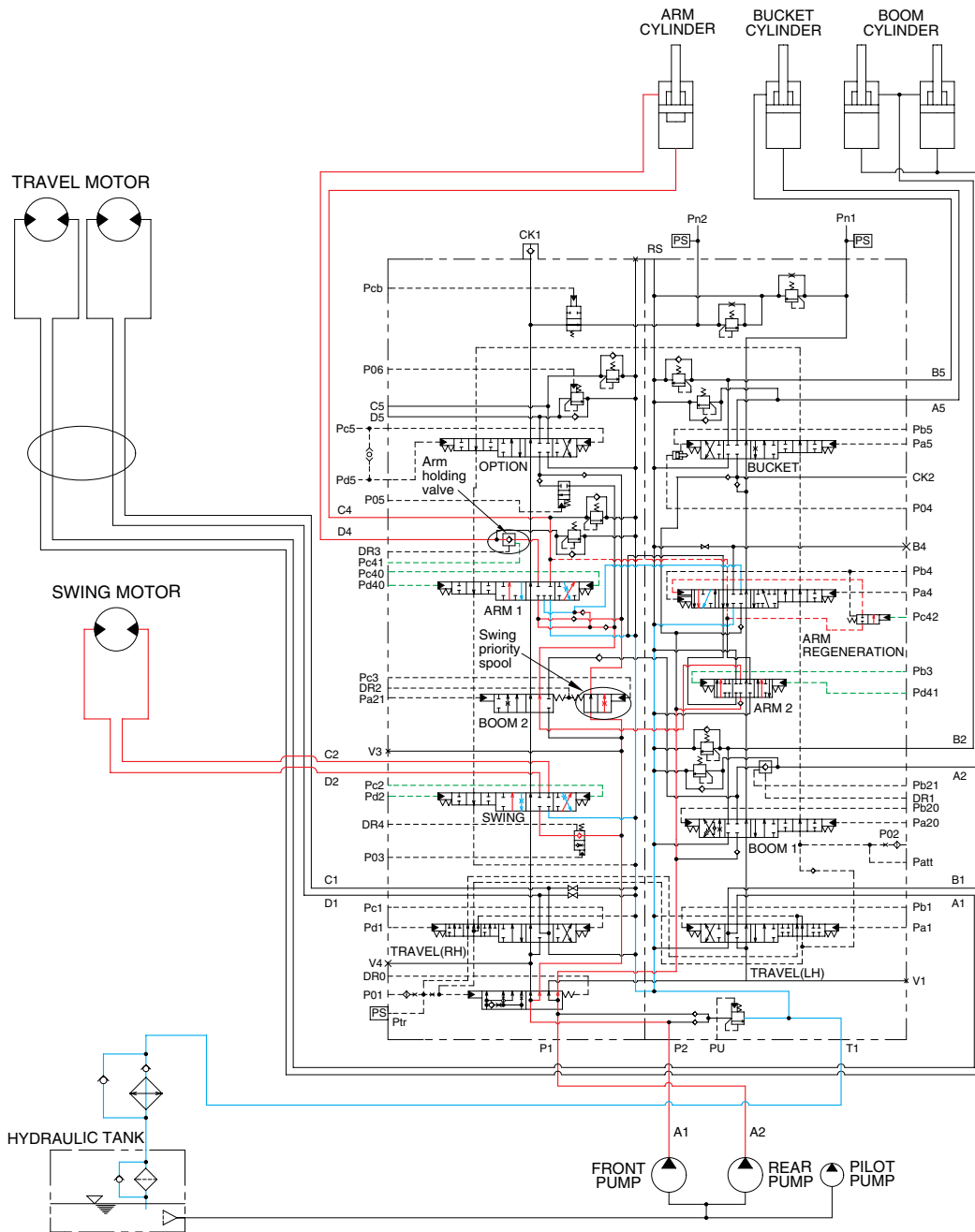

3009A3HC22

When the swing and arm functions are operated, simultaneously the swing spool and arm spools in the main control valve are moved to the functional position by the pilot oil pressure from the remote control valve.

The oil from the A1 pump flows into the swing motor through swing spool and the arm cylinder through arm 1 spool.

The oil from the A2 pump flows into the arm cylinder through the arm 2 spool of the right control valve. The upper structure swings and the arm is operated.

4. COMBINED SWING AND BUCKET OPERATION

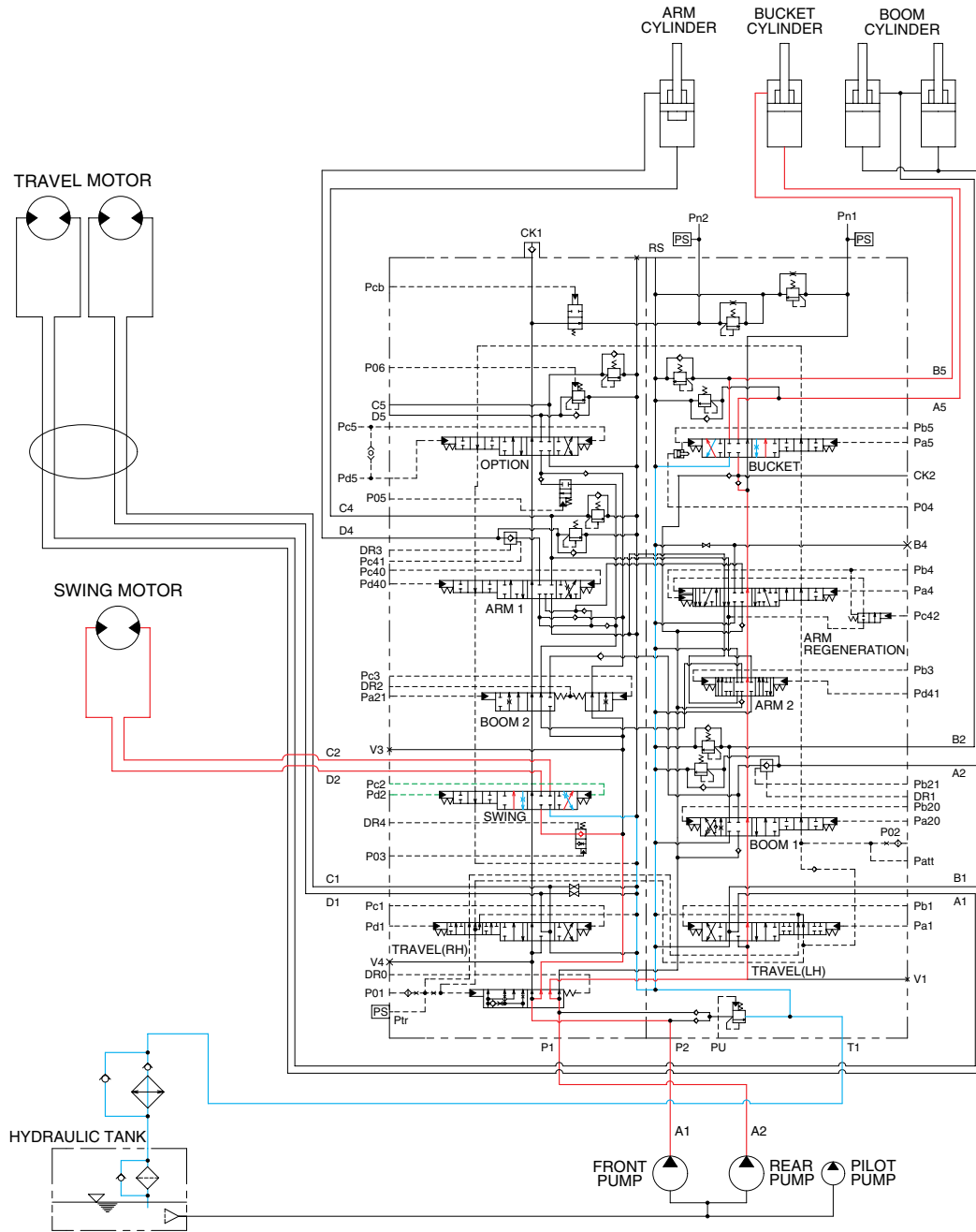

3009A3HC23

When the swing and bucket functions are operated, the swing and bucket spools changed. The oil flows from the A2 pump through the bucket section of the main control valve to the bucket cylinder and the bucket functions. The oil flows from A1 pump through swing section of the main control valve to the swing motor and swing the superstructure.

5. COMBINED SWING AND TRAVEL OPERATION

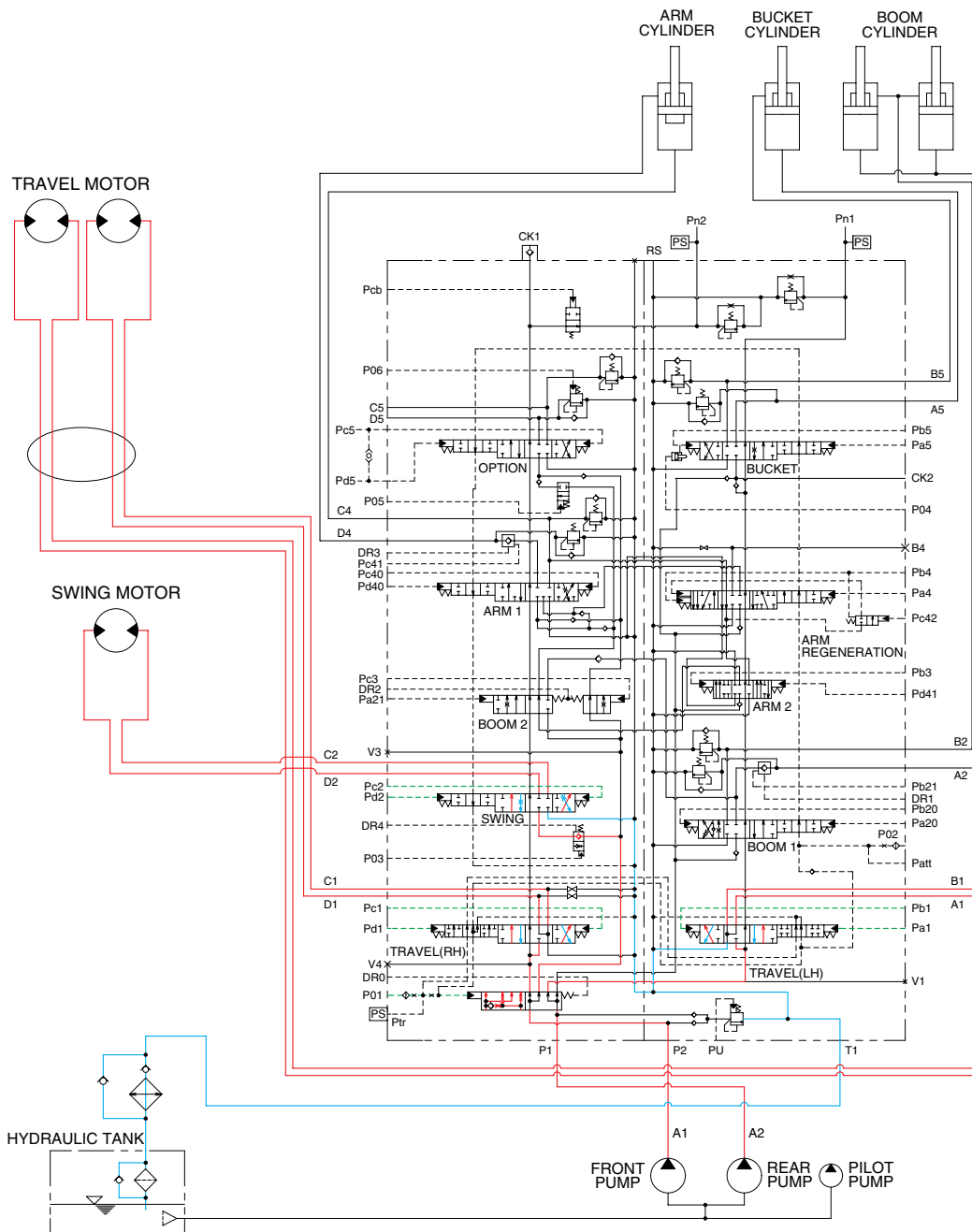

3009A3HC25

When the swing and travel functions are operated, simultaneously the swing spool and travel spools in the main control valve are moved to the functional position by the pilot oil pressure from the remote control valve. At the same time, the straight travel spool is pushed to the right by the pilot oil pressure from the pilot pump.

The oil from the A2 pump flows into the swing motor through the swing spool. The oil from the A1 pump flows into the travel motor through the RH travel spool of the right control valve and the LH travel spool of the left control valve via the straight travel spool.

The superstructure swings and the machine travels straight.

6. COMBINED BOOM AND TRAVEL OPERATION

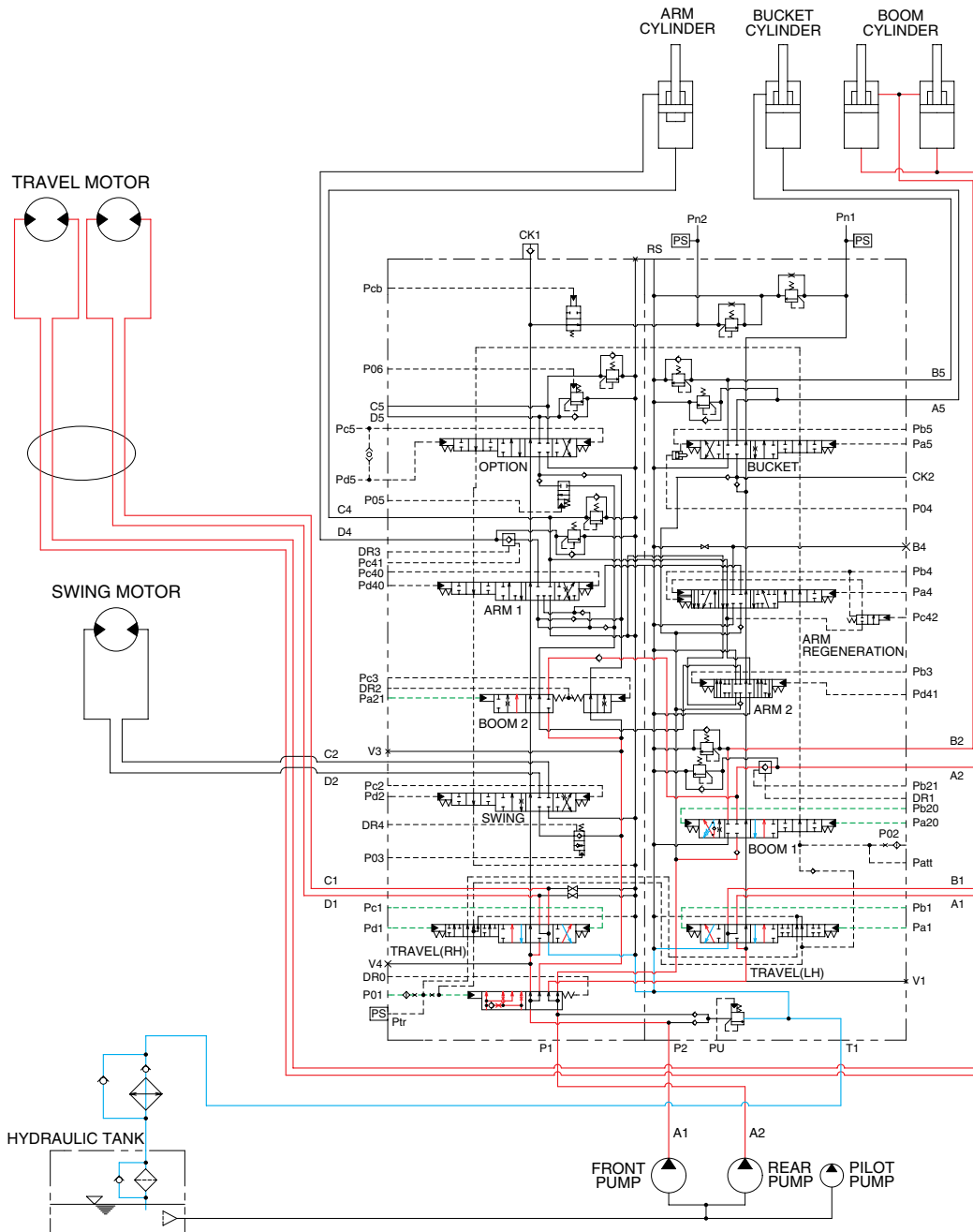

3009A3HC26

When the boom and travel functions are operated, simultaneously the boom spools and travel spools in the main control valve are moved to the functional position by the pilot oil pressure from the remote control valve. At the same time, the straight travel spool is pushed to the right by the pilot oil pressure from the pilot pump. The oil from the A2 pump flows into the boom cylinders through the boom 2 spool and boom 1 spool via the parallel and confluence passage in case boom up operation. The oil from the A1 pump flows into the travel motors through the RH travel spool of the right control valve and the LH travel spool of the left control valve via the straight travel spool.

7. COMBINED ARM AND TRAVEL OPERATION

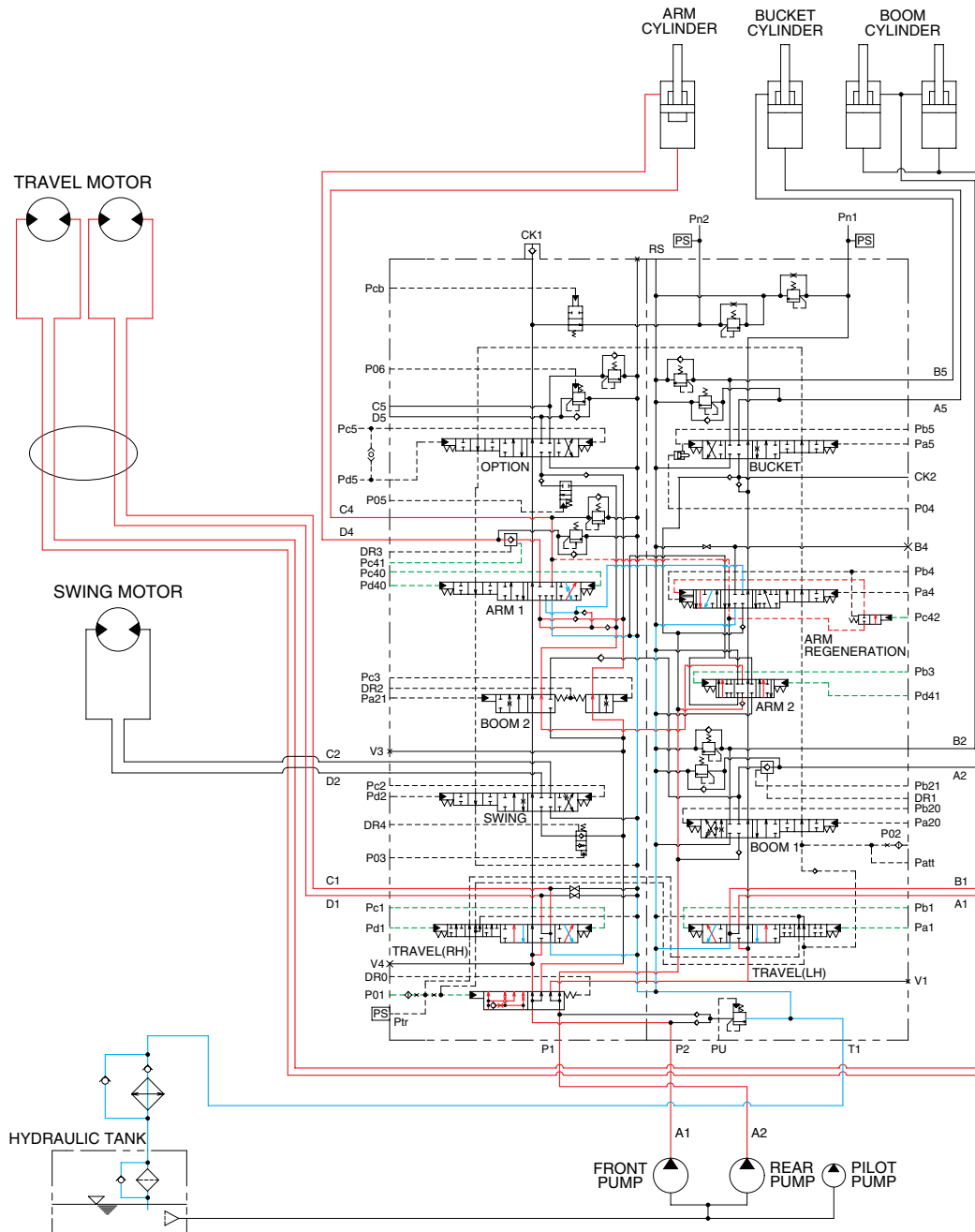

3009A3HC27

When the arm and travel functions are operated, simultaneously the arm spools and travel spools in the main control valve are moved to the functional position by the pilot oil pressure from the remote control valve. At the same time, the straight travel spool is pushed to the right by the pilot oil pressure from the pilot pump. The oil from the A2 pump flows into the arm cylinders through the arm 1 spool and arm 2 spool via the parallel and confluence oil passage. The oil from the A1 pump flows into the travel motors through the RH travel spool of the right control valve and the LH travel spool of the left control valve via the straight travel spool.

8. COMBINED BUCKET AND TRAVEL OPERATION

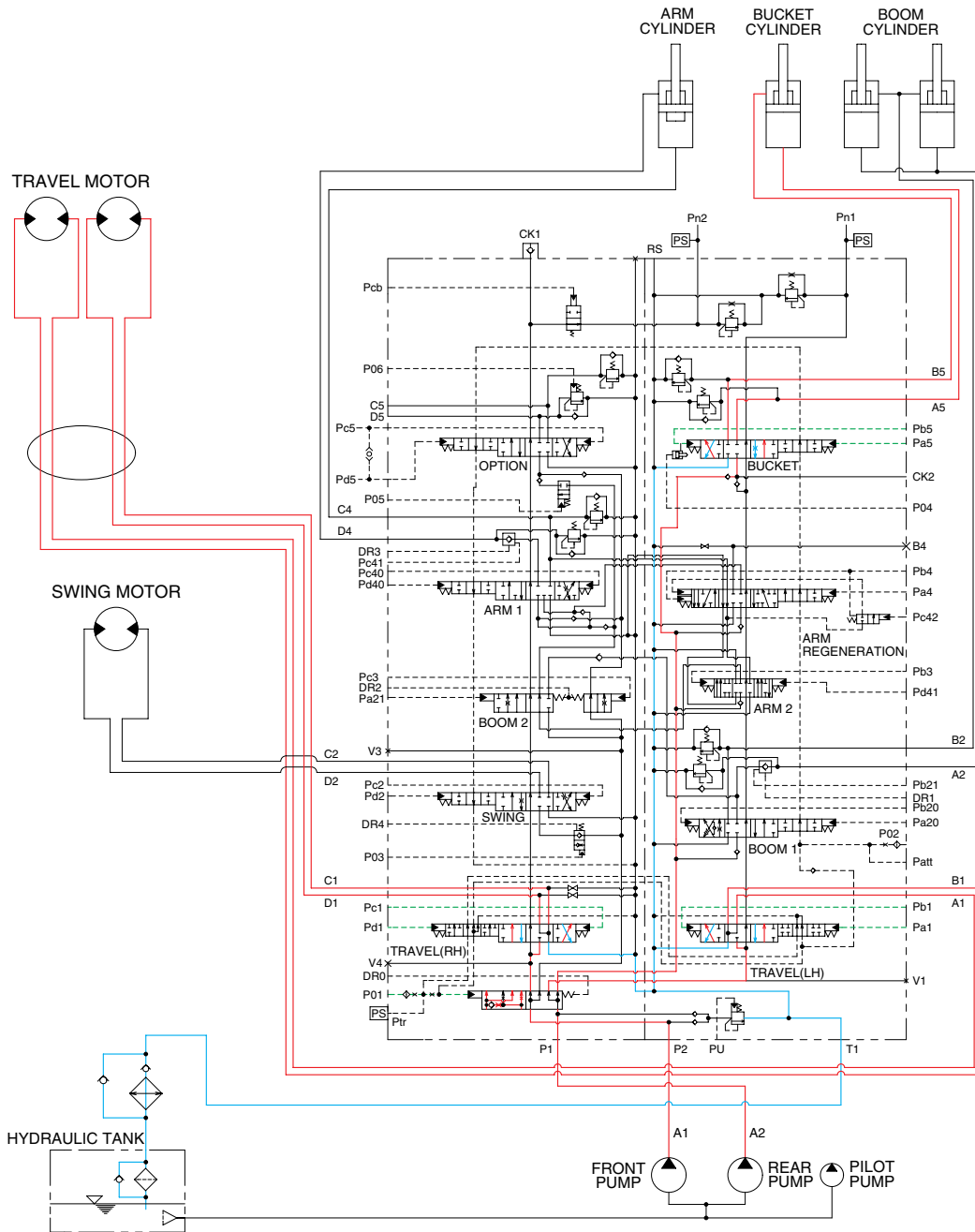

3009A3HC28

When the bucket and travel functions are operated, simultaneously the bucket spool and travel spools in the main control valve are moved to the functional position by the pilot oil pressure from the remote control valve. At the same time, the straight travel spool is pushed to the right by the pilot oil pressure from the pilot pump. The oil from the A2 pump flows into the bucket cylinder through the bucket spool via the confluence oil passage. The oil from the A1 pump flows into the travel motors through the RH travel spool of the right control valve and the LH travel spool of the left control valve via the straight travel spool of the control valve.