

GROUP 9 BOOM, ARM AND BUCKET CYLINDER

1. REMOVAL AND INSTALL

1) BUCKET CYLINDER

(1) Removal

※ Expand the arm and bucket fully, lower the work equipment to the ground and stop the engine.

※ Operate the control levers and pedals several times to release the remaining pressure in the hydraulic piping.

▲ **Loosen the breather slowly to release the pressure inside the hydraulic tank.**

※ Escaping fluid under pressure can penetrate the skin causing serious injury. Fit blind plugs in the hoses after disconnecting them, to prevent dirt or dust from entering.

① Set block between bucket cylinder and arm.

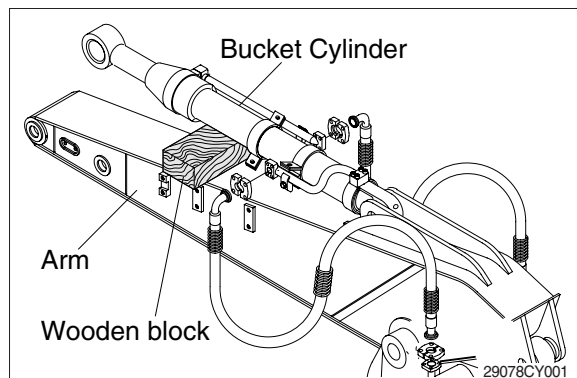

② Remove bolt (2), nut (3) and pull out pin (1).

※ Tie the rod with wire to prevent it from coming out.

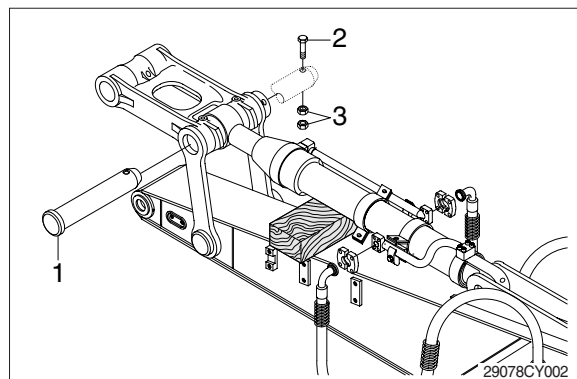

③ Disconnect bucket cylinder hoses (4) and put plugs (5) on cylinder pipe.

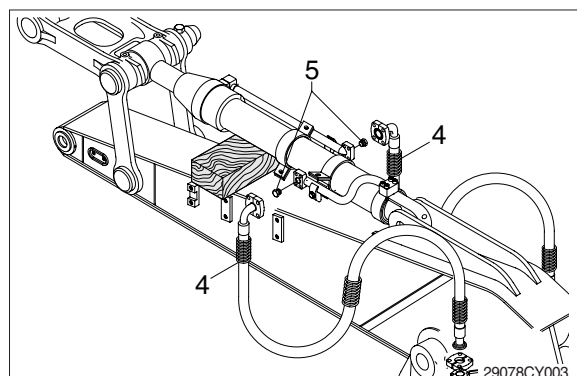

- ④ Sling bucket cylinder assembly (8) and remove bolt (6) then pull out pin (5).
- ⑤ Remove bucket cylinder assembly (8).
 - Weight : 220 kg (485 lb)

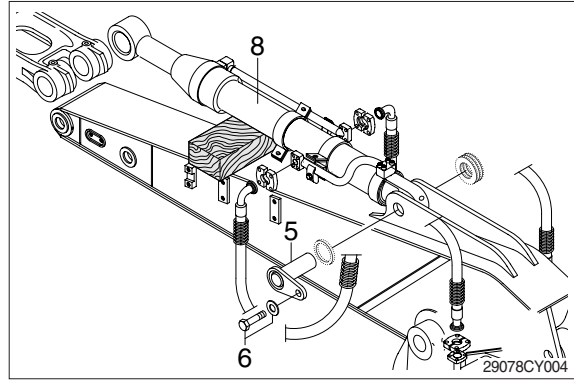

(2) Install

- ① Carry out installation in the reverse order to removal.
- ▲ When aligning the mounting position of the pin, do not insert your fingers in the pin hole.**
- ※ Bleed the air from the bucket cylinder.
 - ※ Confirm the hydraulic oil level and check the hydraulic oil leak or not.

2) ARM CYLINDER

(1) Removal

- ※ Expand the arm and bucket fully, lower the work equipment to the ground and stop the engine.
- ※ Operate the control levers and pedals several times to release the remaining pressure in the hydraulic piping.

▲ Loosen the breather slowly to release the pressure inside the hydraulic tank.

- ※ Escaping fluid under pressure can penetrate the skin causing serious injury. Fit blind plugs in the hoses after disconnecting them, to prevent dirt or dust from entering.

① Set block between arm cylinder and boom.

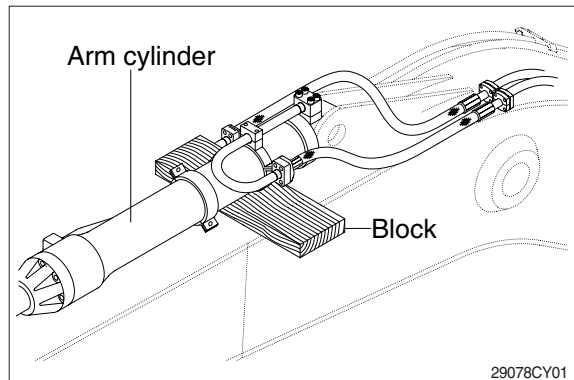

② Remove bolt (2) and pull out pin (1).

- ※ Tie the rod with wire to prevent it from coming out.

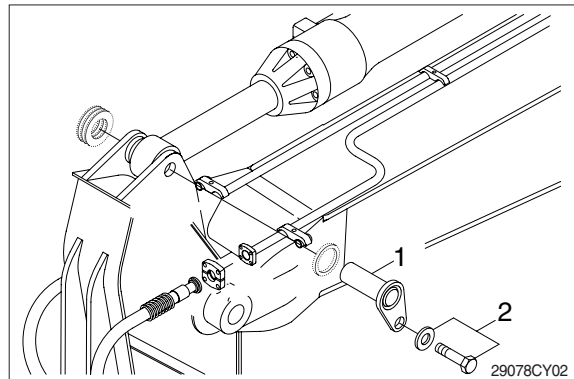

③ Disconnect arm cylinder hoses (4) and put plugs on cylinder pipe.

④ Disconnect greasing pipings (5).

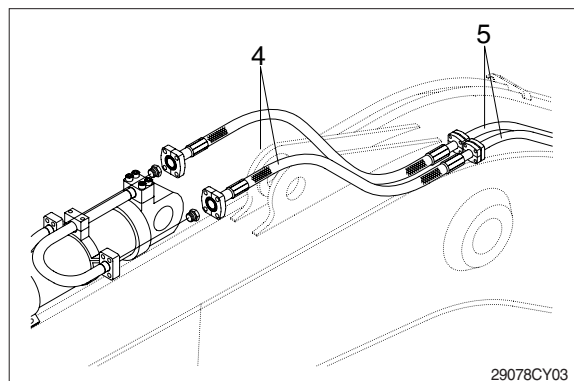

- ⑤ Sling arm assembly (8) and remove bolt (7) then pull out pin (6).
- ⑥ Remove arm cylinder assembly (8).
 - Weight : 360 kg (790 lb)

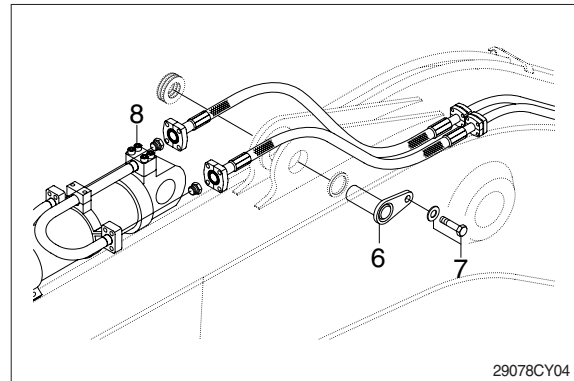

(2) Install

- ① Carry out installation in the reverse order to removal.
- ▲ When aligning the mounting position of the pin, do not insert your fingers in the pin hole.**
- ※ Bleed the air from the arm cylinder.
 - ※ Confirm the hydraulic oil level and check the hydraulic oil leak or not.

3) BOOM CYLINDER

(1) Removal

- ※ Expand the arm and bucket fully, lower the work equipment to the ground and stop the engine.
- ※ Operate the control levers and pedals several times to release the remaining pressure in the hydraulic piping.

▲ Loosen the breather slowly to release the pressure inside the hydraulic tank.

- ※ Escaping fluid under pressure can penetrate the skin causing serious injury. Fit blind plugs in the hoses after disconnecting them, to prevent dirt or dust from entering.

- ① Disconnect greasing hoses (1).
- ② Sling boom cylinder assembly.

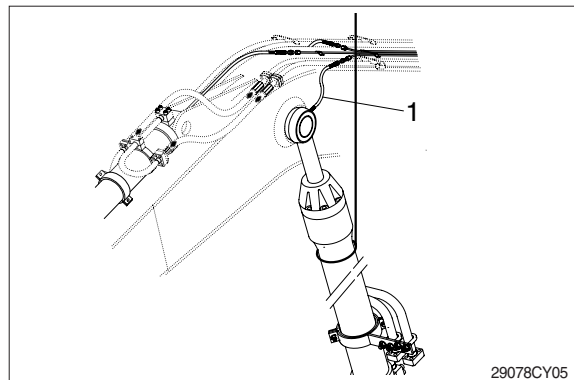

- ③ Remove bolt (4), pin stopper (5) and pull out pin (2).
- ※ Tie the rod with wire to prevent it from coming out.

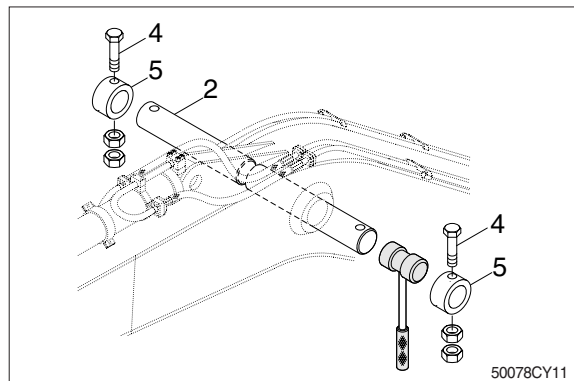

- ④ Lower the boom cylinder assembly (6) on a stand.

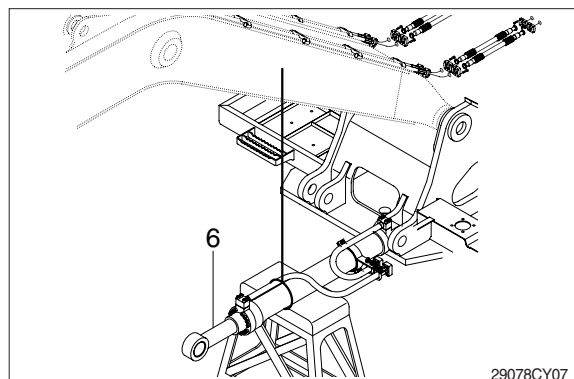

- ⑤ Disconnect boom cylinder hoses (7) and put plugs on cylinder pipe.

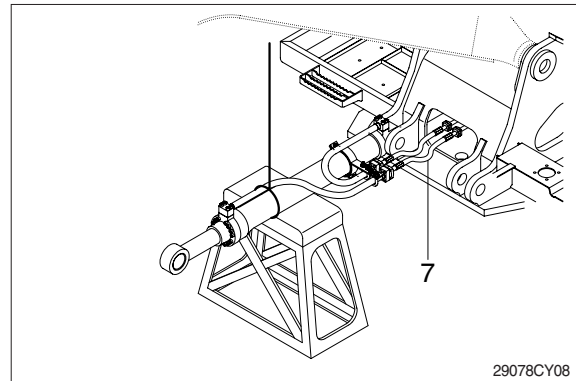

- ⑥ Remove bolt (9) and pull out pin (8).
⑦ Remove boom cylinder assembly (6).
· Weight : 270 kg (600 lb)

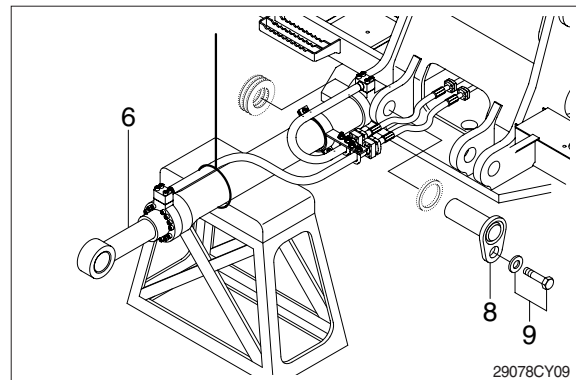

(2) Install

- ① Carry out installation in the reverse order to removal.
- ▲ When aligning the mounting position of the pin, do not insert your fingers in the pin hole.**
- ※ Bleed the air from the boom cylinder.
 - ※ Confirmed the hydraulic oil level and check the hydraulic oil leak or not.

2. DISASSEMBLY AND ASSEMBLY

1) STRUCTURE

(1) Bucket cylinder

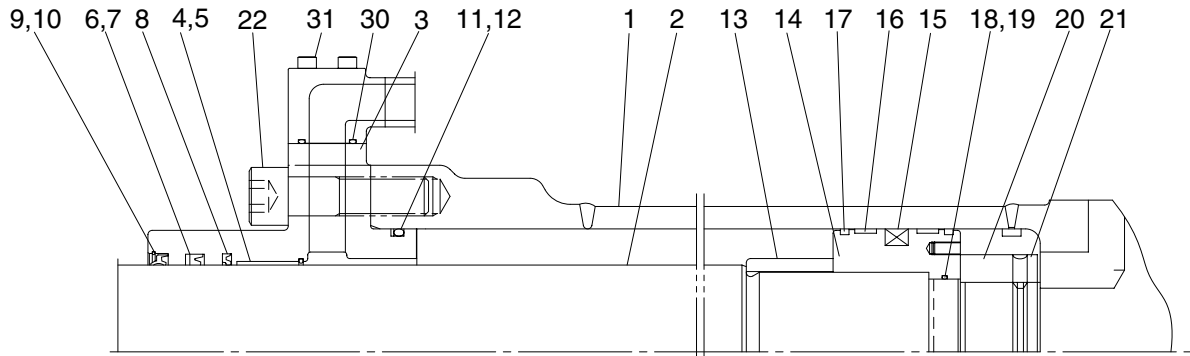

Internal detail

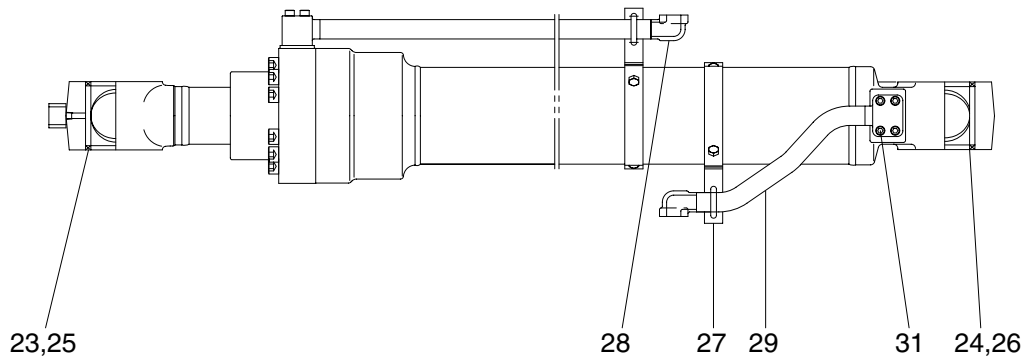

2907A8BY01

1	Tube assembly	12	Back up ring	23	Pin bushing
2	Rod assembly	13	Cushion ring	24	Pin bushing
3	Gland	14	Piston	25	Dust seal
4	DD2 bushing	15	Piston seal	26	Dust seal
5	Snap ring	16	Wear ring	27	Band assembly
6	Rod seal	17	Dust ring	28	Pipe assembly
7	Back up ring	18	O-ring	29	Pipe assembly
8	Buffer ring	19	Back up ring	30	O-ring
9	Dust wiper	20	Lock nut	31	Hexagon socket head bolt
10	Snap ring	21	Hexagon socket set screw		
11	O-ring	22	Hexagon socket head bolt		

(2) Arm cylinder

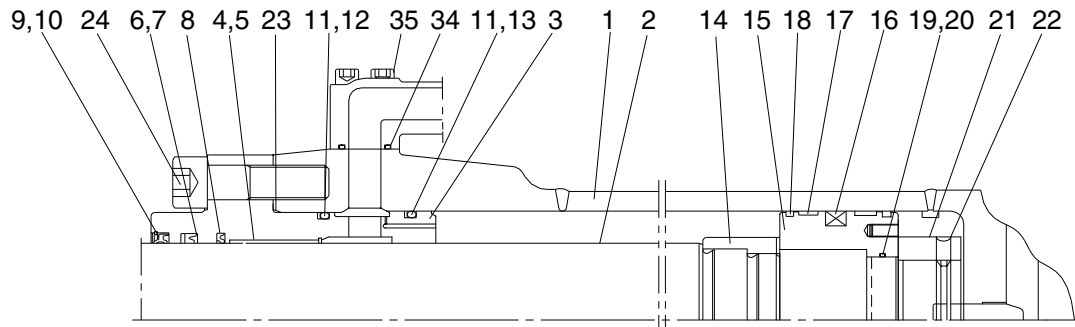

Internal detail

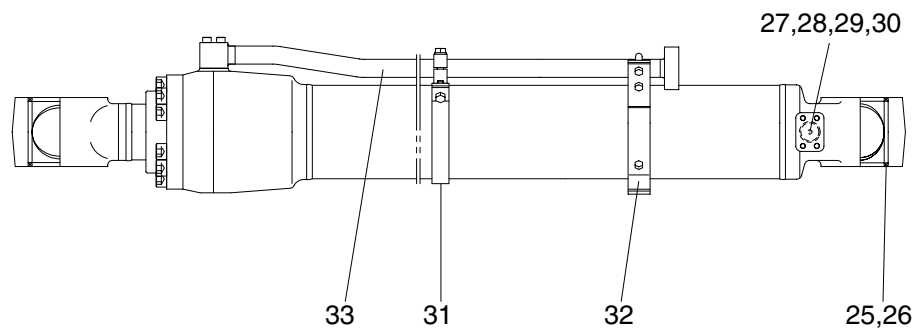

29098AM01

1	Tube assembly	13	Back up ring	25	Pin bushing
2	Rod assembly	14	Cushion ring	26	Dust seal
3	Gland	15	Piston	27	Check valve
4	DD2 bushing	16	Piston seal	28	Coil spring
5	Snap ring	17	Wear ring	29	O-ring
6	Rod seal	18	Dust ring	30	Plug
7	Back up ring	19	O-ring	31	Band assembly
8	Buffer ring	20	Back up ring	32	Band assembly
9	Dust wiper	21	Lock nut	33	Pipe assembly
10	Snap ring	22	Hexagon socket set screw	34	O-ring
11	O-ring	23	O-ring	35	Hexagon socket head bolt
12	Back up ring	24	Hexagon socket head bolt		

(3) Boom cylinder

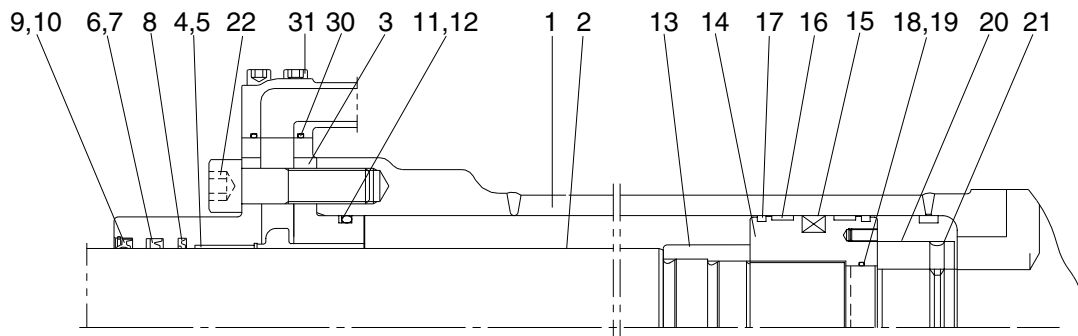

Internal detail

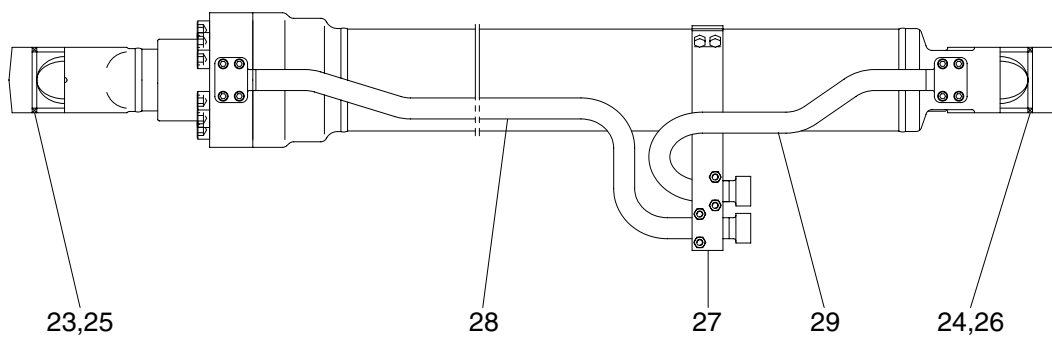

2907A8B001

- | | | | | | |
|----|---------------|----|--------------------------|----|--------------------------|
| 1 | Tube assembly | 12 | Back up ring | 23 | Pin bushing |
| 2 | Rod assembly | 13 | Cushion ring | 24 | Pin bushing |
| 3 | Gland | 14 | Piston | 25 | Dust seal |
| 4 | DD2 bushing | 15 | Piston seal | 26 | Dust seal |
| 5 | Snap ring | 16 | Wear ring | 27 | Band assembly |
| 6 | Rod seal | 17 | Dust ring | 28 | Pipe assembly |
| 7 | Back up ring | 18 | O-ring | 29 | Pipe assembly |
| 8 | Buffer ring | 19 | Back up ring | 30 | O-ring |
| 9 | Dust wiper | 20 | Lock nut | 31 | Hexagon socket head bolt |
| 10 | Snap ring | 21 | Hexagon socket set screw | | |
| 11 | O-ring | 22 | Hexagon socket head bolt | | |

2) TOOLS AND TIGHTENING TORQUE

(1) Tools

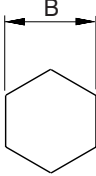
Tools	Remark		
Allen wrench	6		
	8		
	14		
	17		
Spanner	7		
	8		
(-) Driver	Small and large sizes		
Torque wrench	Capable of tightening with the specified torques		

(2) Tightening torque

Part name		Item	Size	Torque	
				kgf · m	lbf · ft
Socket head bolt	Bucket cylinder	22	M18	32.0 ± 3.0	232 ± 21.7
		31	M12	9.4 ± 1.0	68.0 ± 7.2
	Boom cylinder	22	M18	32.0 ± 3.0	232 ± 21.7
		31	M12	9.4 ± 1.0	68.0 ± 7.2
	Arm cylinder	24	M18	32.0 ± 3.0	232 ± 21.7
		35	M12	9.4 ± 1.0	68.0 ± 7.2
Lock nut	Bucket cylinder	20	-	200 ± 10.0	1447 ± 72.3
	Boom cylinder	20	-	200 ± 10.0	1447 ± 72.3
	Arm cylinder	21	-	150 ± 15.0	1085 ± 108
Piston	Bucket cylinder	14	-	100 ± 10.0	723 ± 72.3
	Boom cylinder	14	-	100 ± 10.0	723 ± 72.3
	Arm cylinder	15	-	200 ± 20.0	1447 ± 145

3) DISASSEMBLY

(1) Remove cylinder head and piston rod

※ Procedures are based on the bucket cylinder.

① Hold the clevis section of the tube in a vise.

※ Use mouth pieces so as not to damage the machined surface of the cylinder tube. Do not make use of the outside piping as a locking means.

② Pull out rod assembly (2) about 200 mm (7.1 in). Because the rod assembly is rather heavy, finish extending it with air pressure after the oil draining operation.

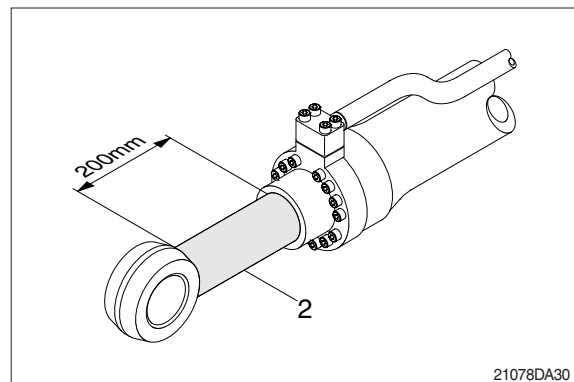

③ Loosen and remove socket bolts (22) of the gland in sequence.

※ Cover the extracted rod assembly (2) with rag to prevent it from being accidentally damaged during operation.

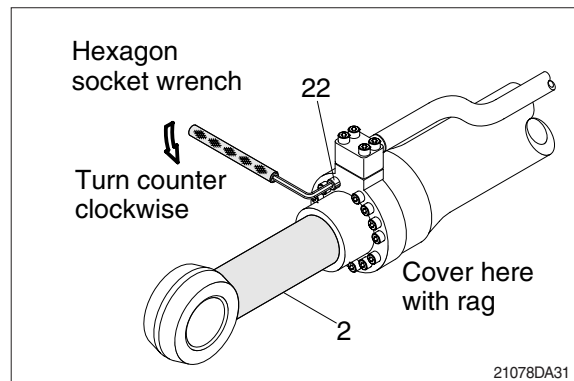

④ Draw out cylinder head and rod assembly together from tube assembly (1).

※ Since the rod assembly is heavy in this case, lift the tip of the rod assembly (2) with a crane or some means and draw it out. However, when rod assembly (2) has been drawn out to approximately two thirds of its length, lift it in its center to draw it completely.

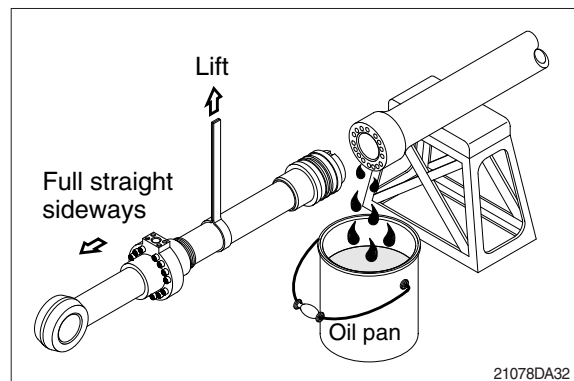

Note that the plated surface of rod assembly (2) is to be lifted. For this reason, do not use a wire sling and others that may damage it, but use a strong cloth belt or a rope.

- ⑤ Place the removed rod assembly on a wooden V-block that is set level.
- ※ Cover a V-block with soft rag.

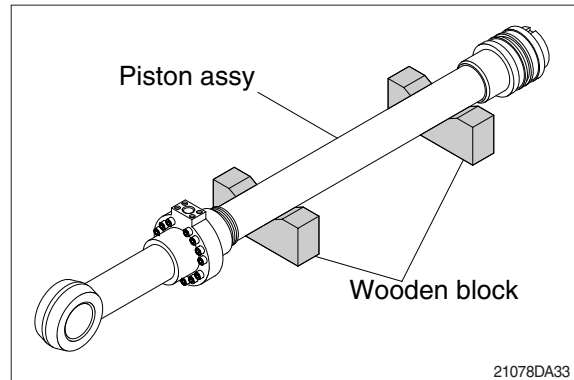

(2) Remove piston and cylinder head

- ① Remove lock nut (20).
- ※ Since lock nut (20) is tightened to a high torque, use a hydraulic and power wrench that utilizes a hydraulic cylinder, to remove the lock nut (20).
- ② Remove piston assembly (14), back up ring (19), and O-ring (18).

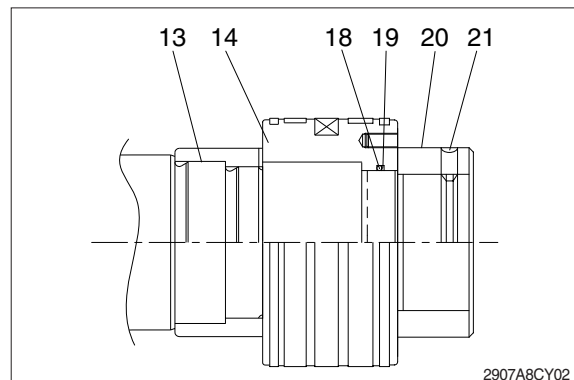

- ③ Remove the cylinder head assembly from rod assembly (2).
- ※ If it is too heavy to move, move it by striking the flanged part of cylinder head with a plastic hammer.
- ※ Pull it straight with cylinder head assembly lifted with a crane. Exercise care so as not to damage the lip of rod bushing (4) and packing (5,6,7,8,9,10) by the threads of rod assembly (2).

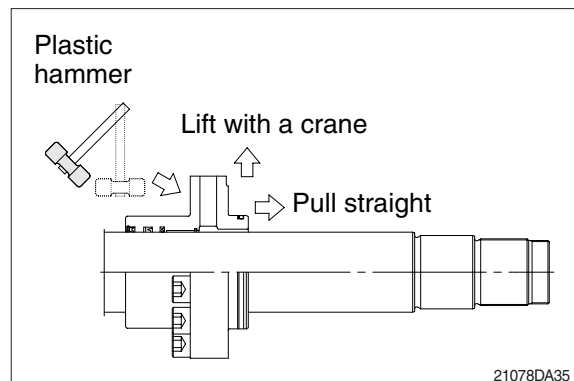

(3) Disassemble the piston assembly

- ① Remove wear ring (16).
 - ② Remove dust ring (17) and piston seal (15).
- ※ Exercise care in this operation not to damage the grooves.

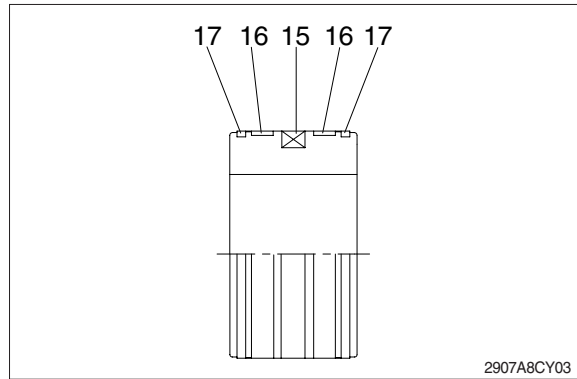

(4) Disassemble cylinder head assembly

- ① Remove back up ring (12) and O-ring (11).
 - ② Remove snap ring (10), dust wiper (9).
 - ③ Remove back up ring (7), rod seal (6) and buffer ring (8).
- ※ Exercise care in this operation not to damage the grooves.
- ※ Do not remove seal and ring, if does not damaged.

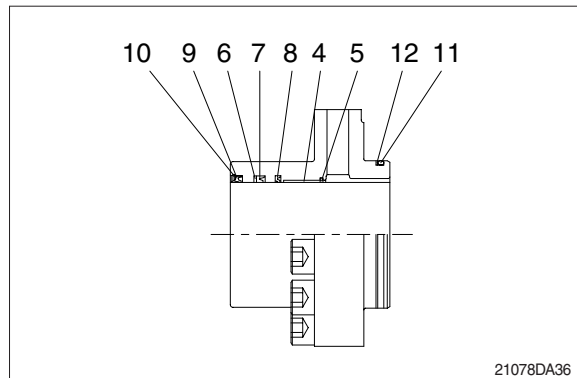

3) ASSEMBLY

(1) Assemble cylinder head assembly

- ※ Check for scratches or rough surfaces if found smooth with an oil stone.
- ① Coat the inner face of gland (3) with hydraulic oil.

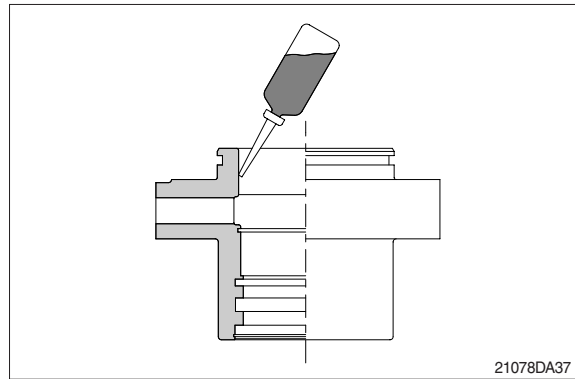

- ② Coat dust wiper (9) with grease and fit dust wiper (9) to the bottom of the hole of dust seal.
At this time, press a pad metal to the metal ring of dust seal.
- ③ Fit snap ring (10) to the stop face.

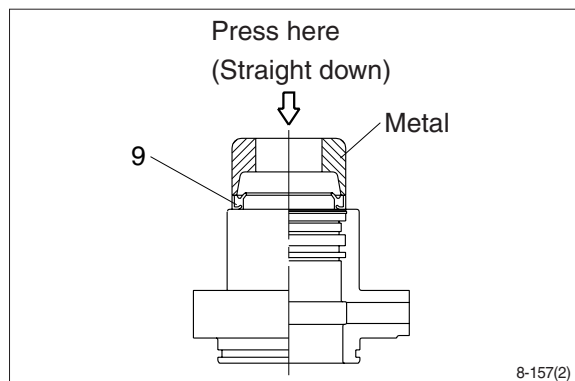

- ④ Fit back up ring (7), rod seal (6) and buffer ring (8) to corresponding grooves, in that order.
 - ※ Coat each packing with hydraulic oil before fitting it.
 - ※ Insert the backup ring until one side of it is inserted into groove.

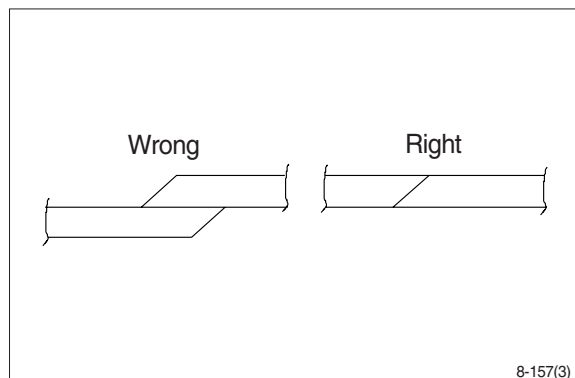

- ※ Rod seal (6) has its own fitting direction. Therefore, confirm it before fitting them.
- ※ Fitting rod seal (6) upside down may damage its lip. Therefore check the correct direction that is shown in fig.

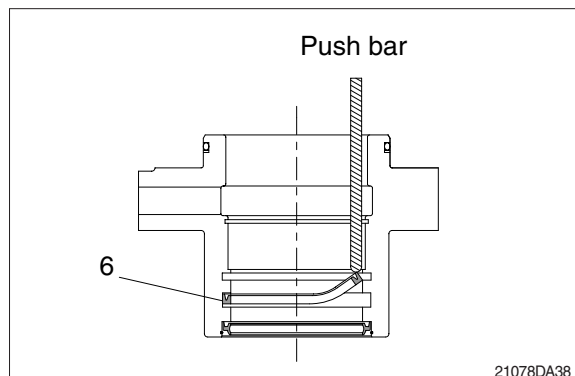

- ⑤ Fit back up ring (12) to gland (3).
- ※ Put the backup ring in the warm water of 30~50°C.
- ⑥ Fit O-ring (11) to gland (3).

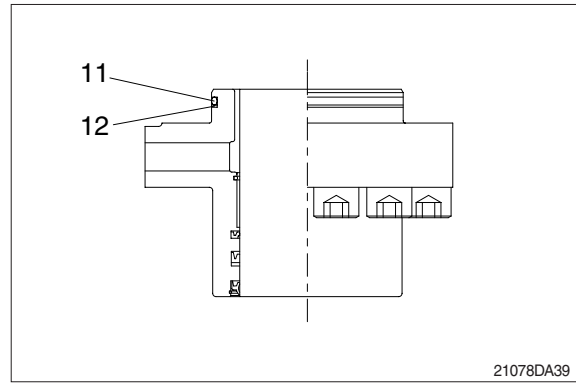

(2) Assemble piston assembly

- ※ Check for scratches or rough surfaces. If found smooth with an oil stone.
- ① Coat the outer face of piston (14) with hydraulic oil.

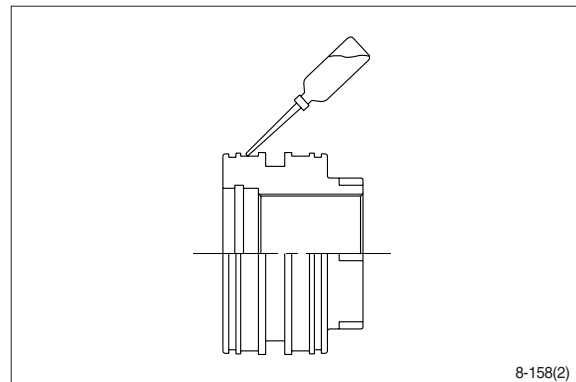

- ② Fit piston seal (15) to piston.
- ※ Put the piston seal in the warm water of 60~100°C for more than 5 minutes.
- ※ After assembling the piston seal, press its outer diameter to fit in.

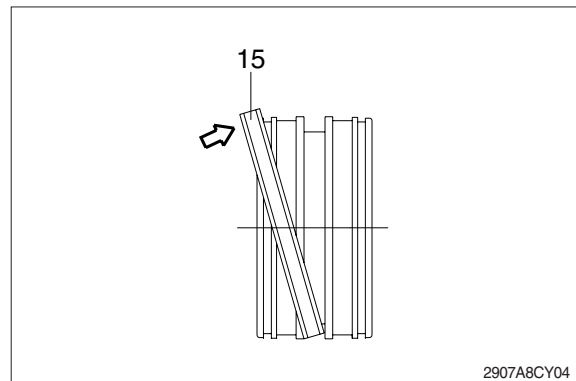

- ③ Fit wear ring (16) and dust ring (17) to piston (14).

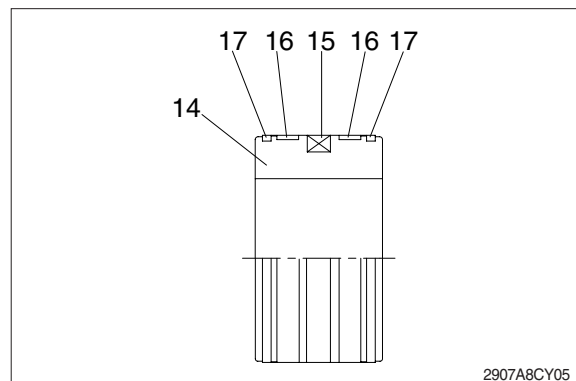

(3) Install piston and cylinder head

- ① Fix the rod assembly to the work bench.
- ② Apply hydraulic oil to the outer surface of rod assembly (2), the inner surface of piston and cylinder head.
- ③ Insert cylinder head assembly to rod assembly.

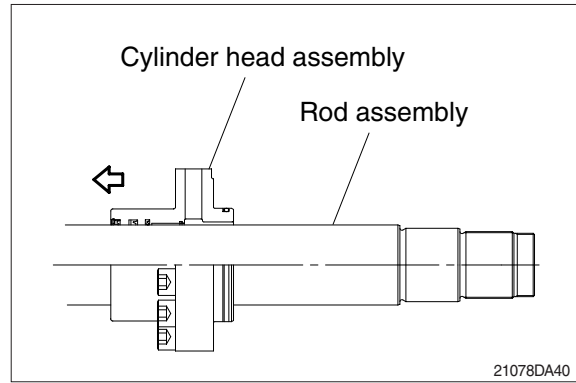

- ④ Insert cushion ring (13) to rod assembly.
- ※ Note that cushion ring (13) has a direction in which it should be fitted.

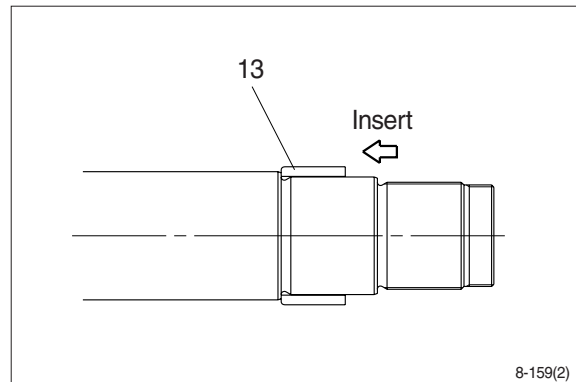

- ⑤ Fit piston assembly to rod assembly.
- Tightening torque : $100 \pm 10.0 \text{ kgf} \cdot \text{m}$
($723 \pm 72.3 \text{ lbf} \cdot \text{ft}$)

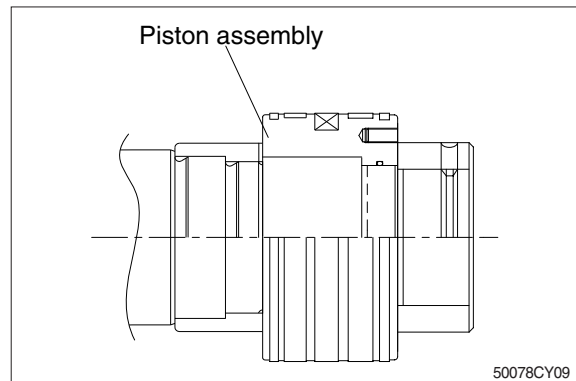

- ⑥ Fit lock nut (20) and tighten the screw (21).
- Tightening torque :

Item		kgf · m	lbf · ft
Bucket	20	200 ± 20	1447 ± 145
	21	5.4 ± 0.5	391 ± 3.6
Arm	21	150 ± 15	1085 ± 108
	22	5.4 ± 0.5	39.1 ± 3.6

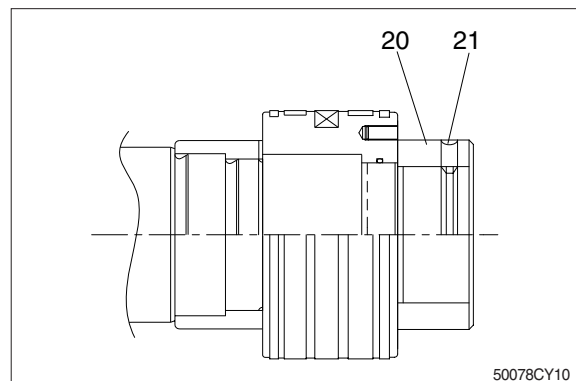

(3) Overall assemble

- ① Place a V-block on a rigid work bench.
Mount the tube assembly (1) on it and fix the assembly by passing a bar through the clevis pin hole to lock the assembly.
- ② Insert the rod assembly in to the tube assembly, while lifting and moving the rod assembly with a crane.
 - ※ Be careful not to damage piston seal by thread of tube assembly.
- ③ Match the bolt holes in the cylinder head flange to the tapped holes in the tube assembly and tighten socket bolts to a specified torque.
 - ※ Refer to the table of tightening torque.

