

GROUP 2 ELECTRICAL CIRCUIT

ELECTRICAL CIRCUIT(1/2)

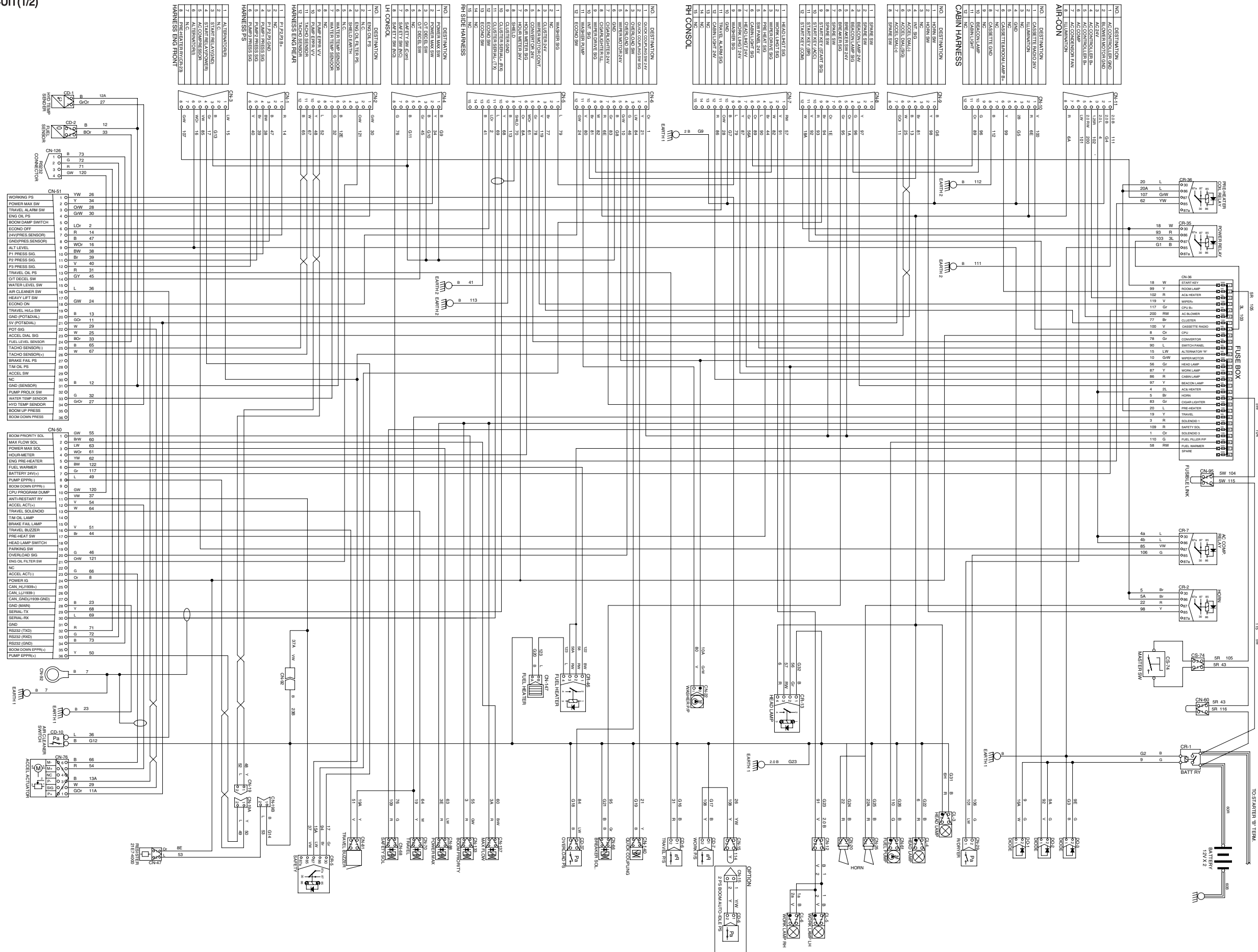

ENGINE FRONT HARNESS

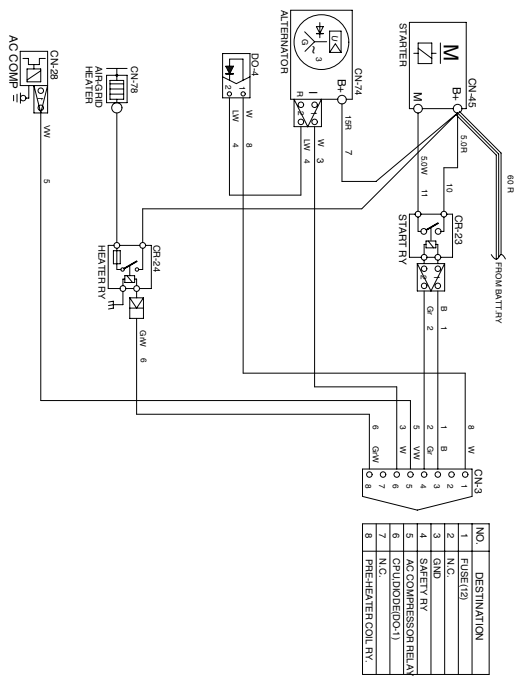

ENGINE HARNESS REAR

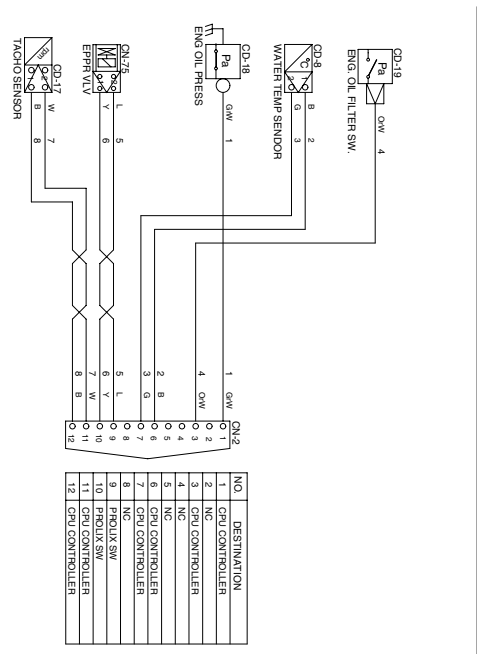

CABIN HARNESS

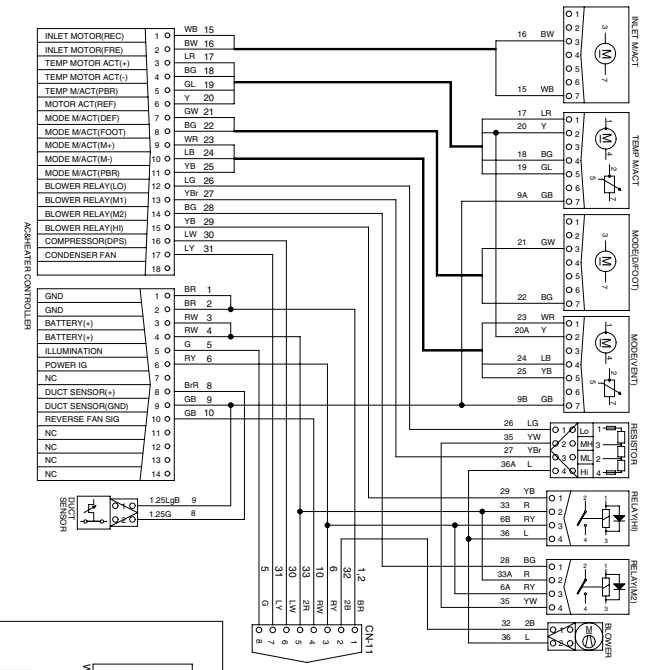
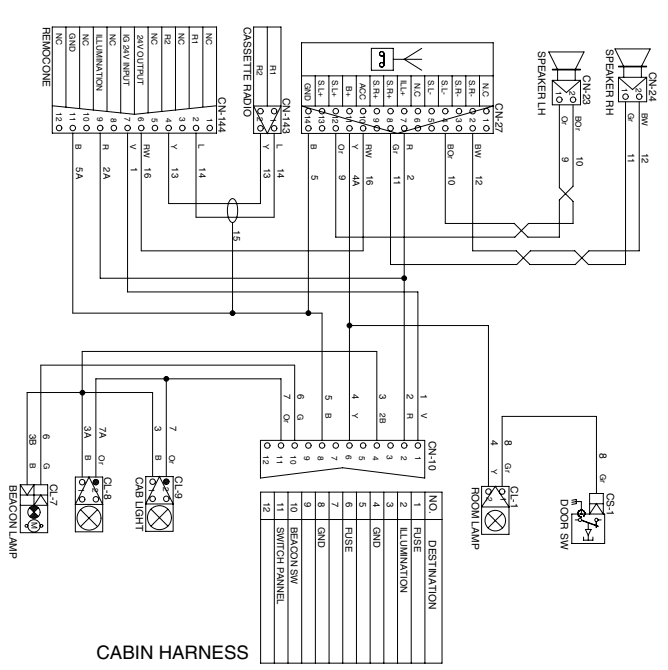

AIR CON

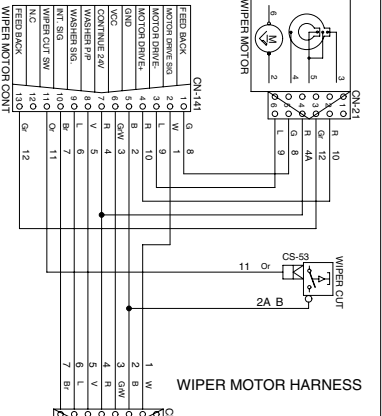

WIPER MOTOR HARNESS

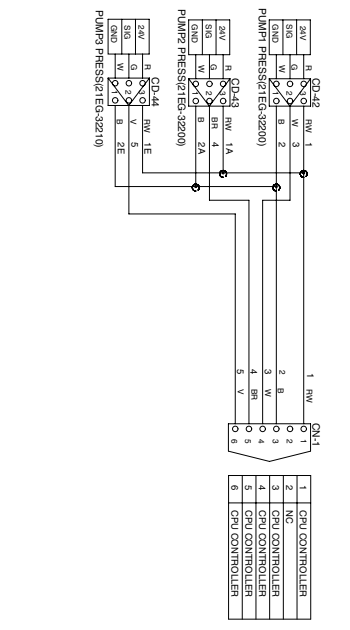

HARNESS PUMP PS

LH HARNESS

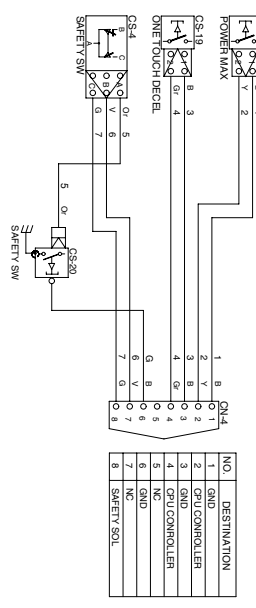

RH HARNESS

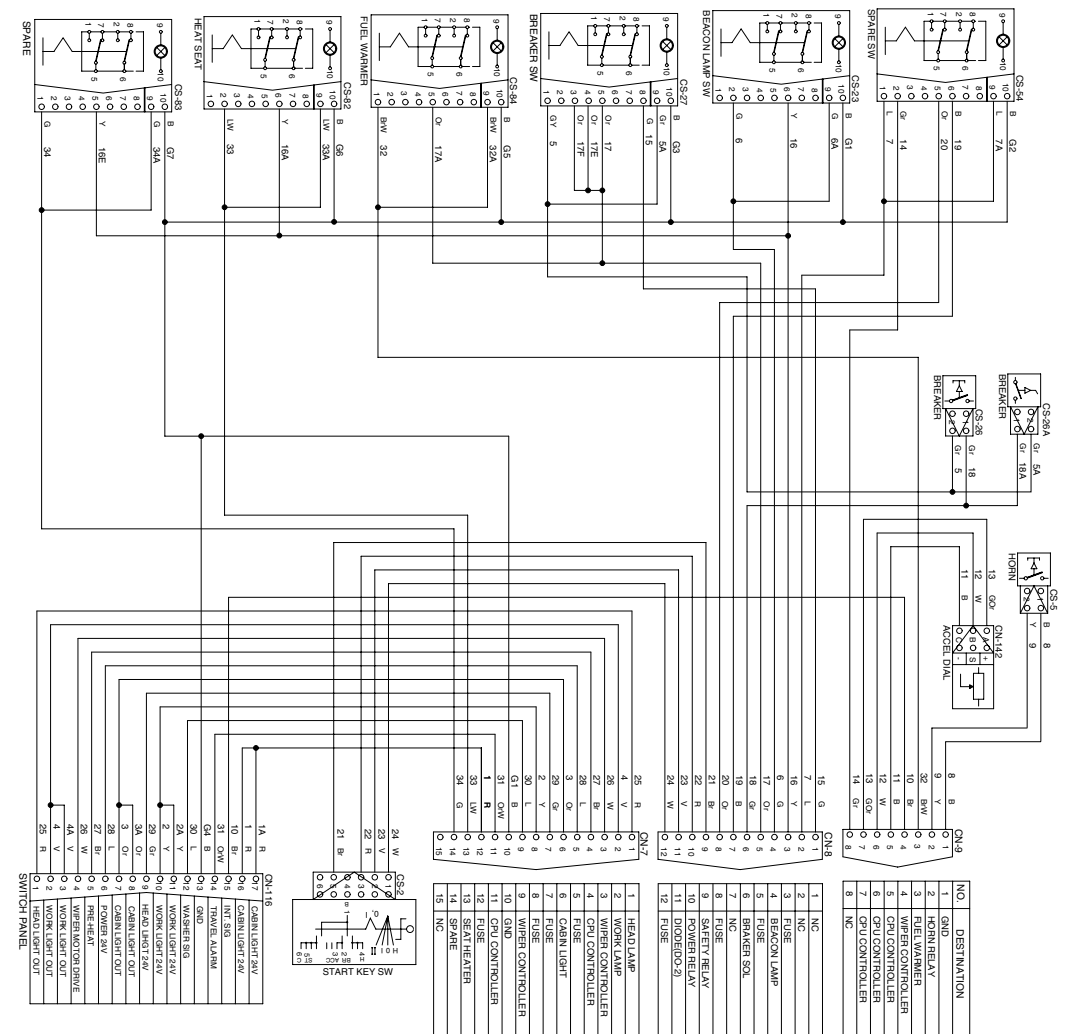

1. POWER CIRCUIT

The negative terminal of battery is grounded to the machine chassis through master switch.

When the start switch is in the OFF position, the current flows from the positive battery terminal as shown below.

1) OPERATING FLOW

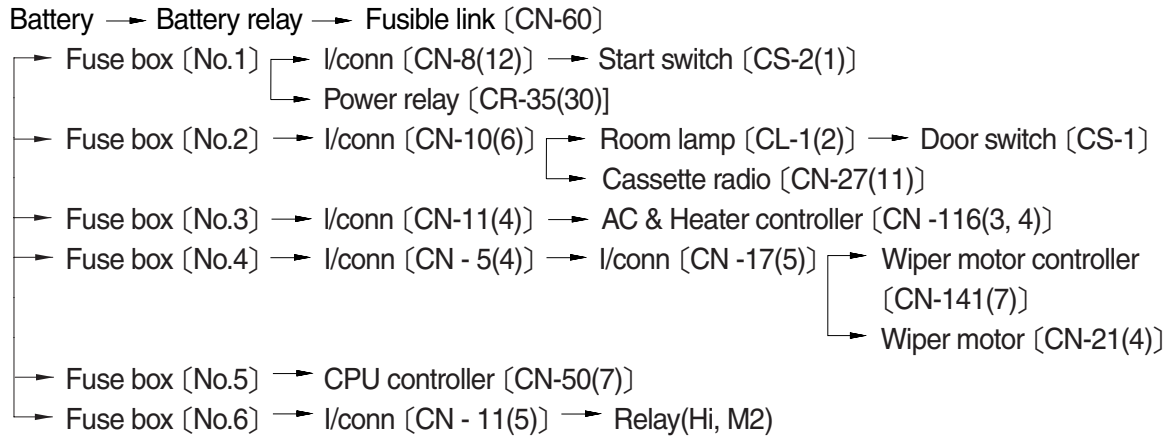

※ I/conn : Intermediate connector

2) CHECK POINT

Engine	Start switch	Check point	Voltage
OFF	OFF	① - GND (Battery 1EA)	10~12.5V
		② - GND (Battery 2EA)	20~25V
		③ - GND (Battery 2EA)	20~25V
		④ - GND (Fusible link)	20~25V

※ GND : Ground

POWER CIRCUIT

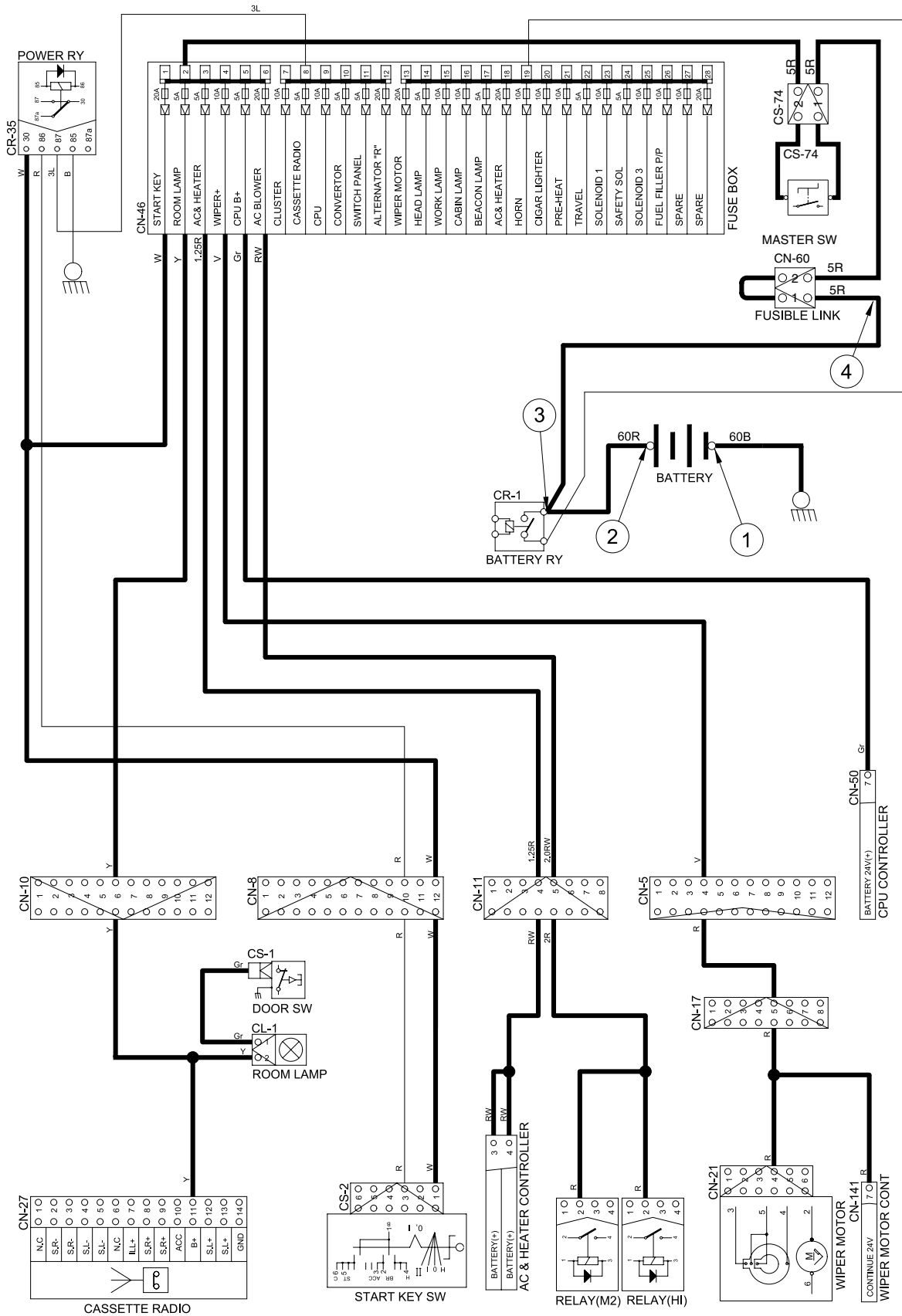

300074EL05

2. STARTING CIRCUIT

1) OPERATING FLOW

Battery(+) terminal → Battery relay〔CR-1〕 → Fusible link 〔CN-60〕
 → Fuse box 〔No.1〕 → I/conn 〔CN-8(12)〕 → Start switch 〔CS-2(1)〕

(1) When start key switch is in ON position

→ Start switch ON 〔CS-2(2)〕 → I/conn 〔CN-8(11)〕 → Battery relay 〔CR-1〕
 → Battery relay operating (All power is supplied with the electric component)
 → Start switch ON 〔CS-2(3)〕 → I/conn 〔CN-8(10)〕 → Power relay 〔CR-35(86) → (87)〕
 → Fuse box 〔No.12〕 → I/conn 〔CN-3(1)〕 → Alternator 〔CN-74(2)〕
 → Safety relay 〔CR-5(87)〕

(2) When start key switch is in START position

Start switch START 〔CS-2(5)〕 → I/conn 〔CN-8(9)〕 → Anti-restart relay 〔CR-5(86) → (30)〕
 → I/conn 〔CN-3(4)〕 → Start relay 〔CR-23〕

2) CHECK POINT

Engine	Start switch	Check point	Voltage
OPERATING	START	① - GND(Battery) ② - GND(Start key) ③ - GND(Battery relay M4) ④ - GND(Starter B ⁺) ⑤ - GND(Starter M) ⑥ - GND(Start relay) ⑦ - GND(Battery relay M8)	20~25V

※ GND : Ground

STARTING CIRCUIT

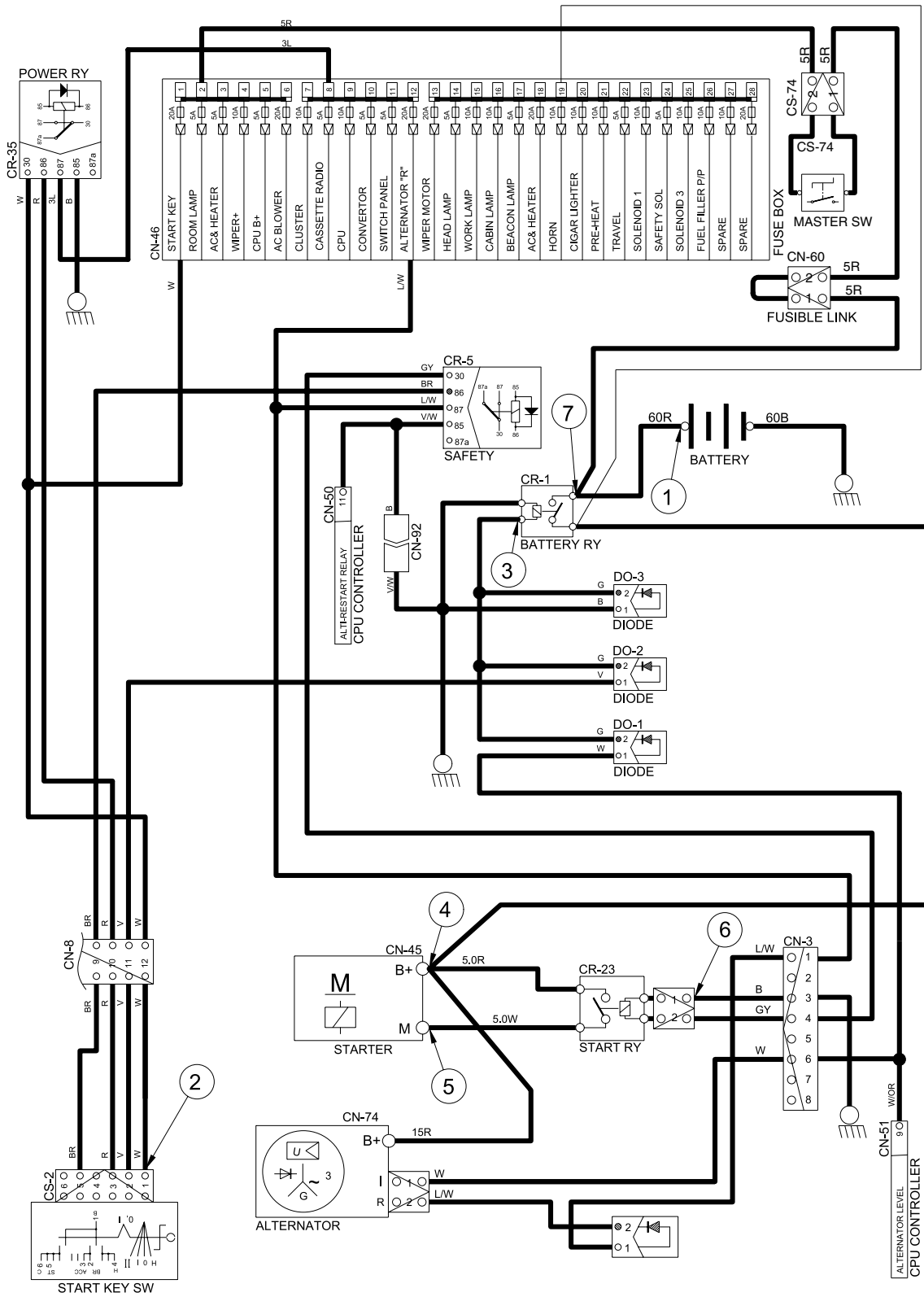

300074EL06

3. CHARGING CIRCUIT

When the starter is activated and the engine is started, the operator releases the key switch to the ON position.

Charging current generated by operating alternator flows into the battery through the battery relay (CR-1).

The current also flows from alternator to each electrical component and controller through the fuse box.

1) OPERATING FLOW

(1) Warning flow

Alternator "I" terminal → I/conn [CN-3(6)] → CPU alternator level [CN-51(95)]
Cluster charging warning lamp(Via serial interface)

(2) Charging flow

Alternator "B+" terminal → Battery relay(M8) → Battery(+) terminal
→ Fusible link [CS-60] → Fuse box

2) CHECK POINT

Engine	Start switch	Check point	Voltage
Run	ON	① - GND(Battery voltage) ② - GND(Battery relay) ③ - GND(Alternator B ⁺ terminal) ④ - GND(Alternator I terminal) ⑤ - GND(CPU)	20~30V

※ GND : Ground

5. BEACON LAMP AND CAB LIGHT CIRCUIT

1) OPERATING FLOW

Fuse box (No.17) → I/conn [CN-8(3)] → Beacon lamp switch [CN-23(6)]

Fuse box (No.16) → I/conn [CN-7(12)] → Switch panel [CN-116(16, 17)]

(1) Beacon lamp switch ON

Beacon lamp switch ON [CS-23(2)] → Switch Indicator lamp ON [CS-23(9)]
 → I/conn [CN-8(4)] → I/conn [CN-10(10)]
 → Beacon lamp ON [CL-7]

(2) Cab light switch ON

Cab light switch ON [CN-116(7, 8)] → I/conn [CN-7(6)] → I/conn [CN-10(11)]

→ Cab light ON [CL-8(2), CL-9(2)]

2) CHECK POINT

Engine	Start switch	Check point	Voltage
STOP	ON	① - GND(Fuse box) ② - GND(Switch power input) ③ - GND(Switch power output) ④ - GND(Beacon lamp)	20~25V
STOP	ON	⑤ - GND(Fuse box) ⑥ - GND(Switch power input) ⑦ - GND(Switch power output) ⑧ - GND(Cab light)	20~25V

※ GND : Ground

BEACON LAMP AND CAB LIGHT CIRCUIT

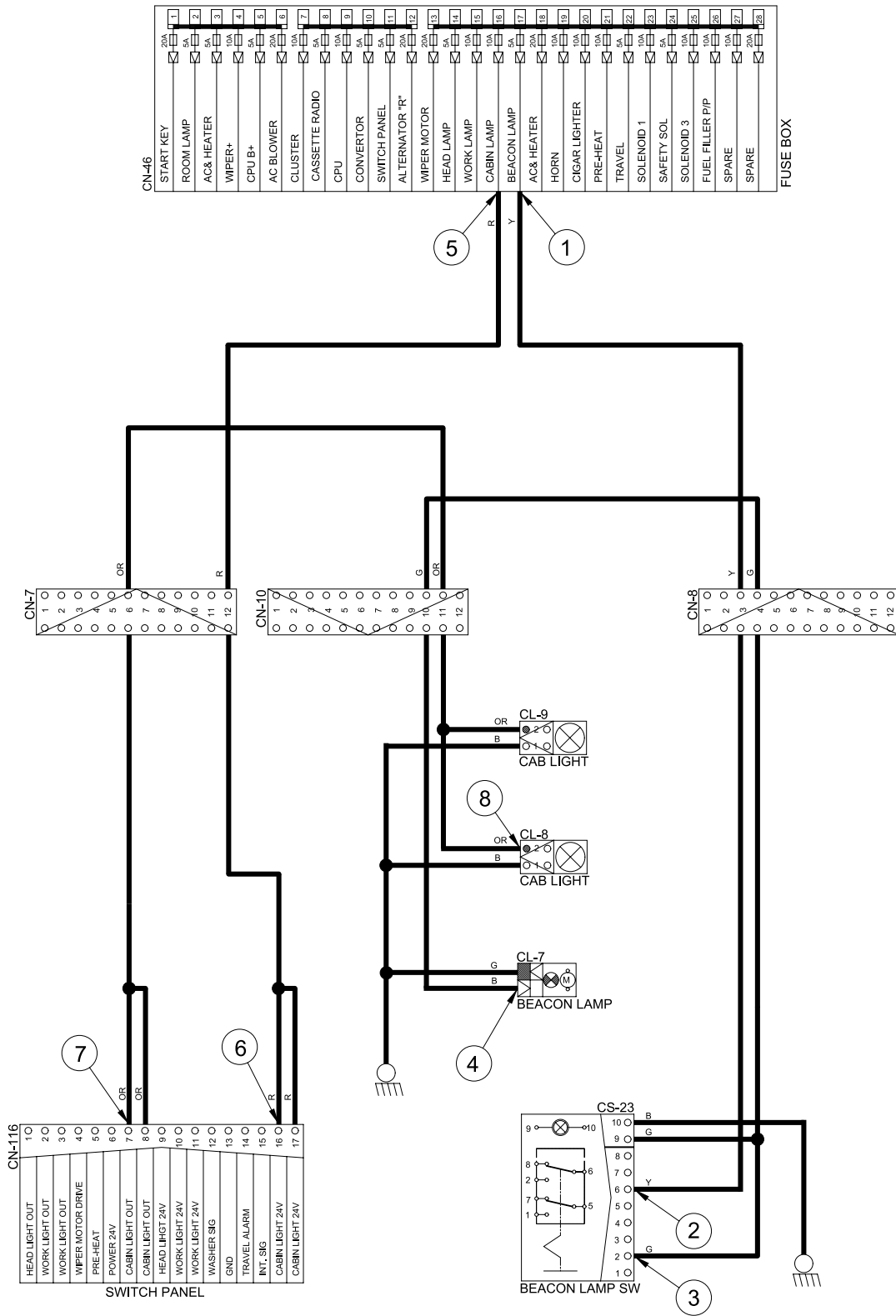

6. WIPER AND WASHER CIRCUIT

1) OPERATING FLOW

(1) Key switch ON

Fuse box (No.11) → I/conn [CN-7(5)] → Switch panel [CN-116(6)]

Fuse box (No.4) → I/conn [CN-5(4)] → I/conn [CN-17(5)] → Wiper motor controller [CN-141(7)]
 → Wiper motor [CN-21(4)]

Fuse box (No.13) → I/conn [CN-6(5)] → I/conn [CN-17(4)] → Wiper motor controller [CN-141(6)]
 → Washer pump [CN-22(2)]

(2) Wiper switch ON : 1st step(Intermittent)

Wiper switch ON [CN-116(15)] → I/conn[CN-9(4)] → I/conn[CN-6(10)] → I/conn[CN-17(8)]

→ Wiper motor controller [CN-141(10) → (3)] → Wiper motor intermittently operating [CN-21(6)]

(3) Wiper switch ON : 2nd step(Low speed)

Wiper switch ON [CN-116(4)] → I/conn [CN-7(3)] → I/conn [CN-6(9)] → I/conn[CN-17(2)]

Wiper motor controller [CN-141(2) → (4)] → Wiper motor operating [CN-21(2)]

(4) Washer switch ON

Washer switch ON [CN-116(12)] → I/conn [CN-7(9)] → I/conn [CN-5(1)] → I/conn [CN-17(7)]

→ Wiper motor controller [CN-141(9) → (8)] → I/conn [CN-17(6)] → I/conn [CN-6(11)]

→ Washer pump [CN-22(1)] → Washer operating

Wiper switch ON [CN-116(4)] → I/conn [CN-7(3)] → I/conn [CN-6(9)] → I/conn[CN-17(2)]

Wiper motor controller [CN-141(2) → (4)] → Wiper motor operating [CN-21(2)]

(5) Auto parking(When switch OFF)

Switch OFF [CN-116(15)] → Wiper motor parking position by wiper motor controller

2) CHECK POINT

Engine	Start switch	Check point	Voltage
STOP	ON	① - GND(Fuse box)	24V
		② - GND(Switch power input)	
		③ - GND(Switch power output)	0 ~ 5V
		④ - GND(Wiper Power input)	
		⑤ - GND(Wiper power output)	0 or 24V
		⑥ - GND(Wiper motor)	

※ GND : Ground

CONTROLLER CIRCUIT

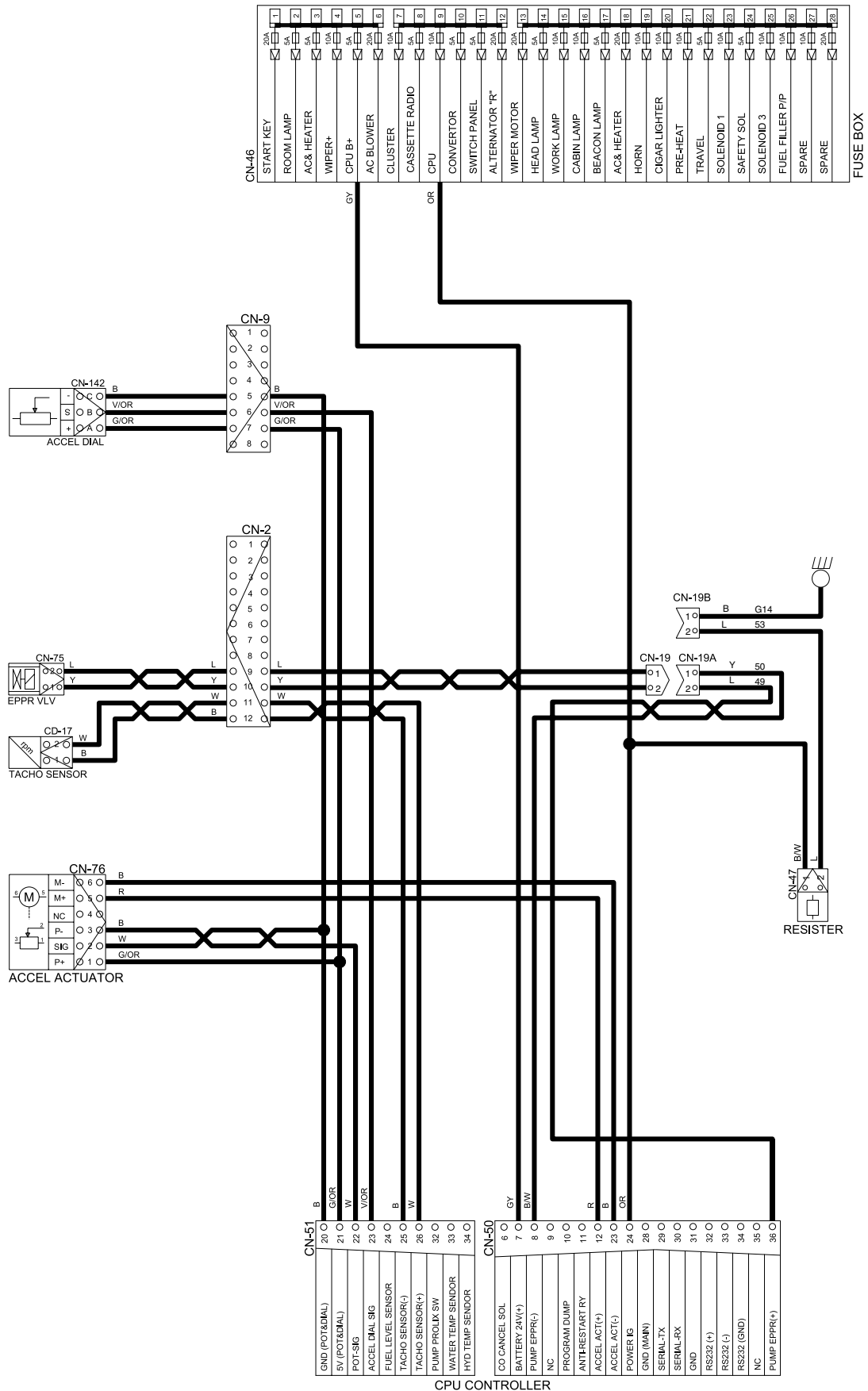

300074EL11