

# GROUP 4 MECHATRONICS SYSTEM

## 1. ALL ACTUATORS SPEED ARE SLOW

- ※ Boom, Arm, Grapple, Swing and travel speed are slow, but engine speed is good.
- ※ Spec : P-mode 1850 ± 50 rpm    S-mode 1750 ± 50 rpm    E-mode 1600 ± 50 rpm
- ※ Before carrying out below procedure, check all the related connectors are properly inserted and fault code on the cluster.

### 1) INSPECTION PROCEDURE

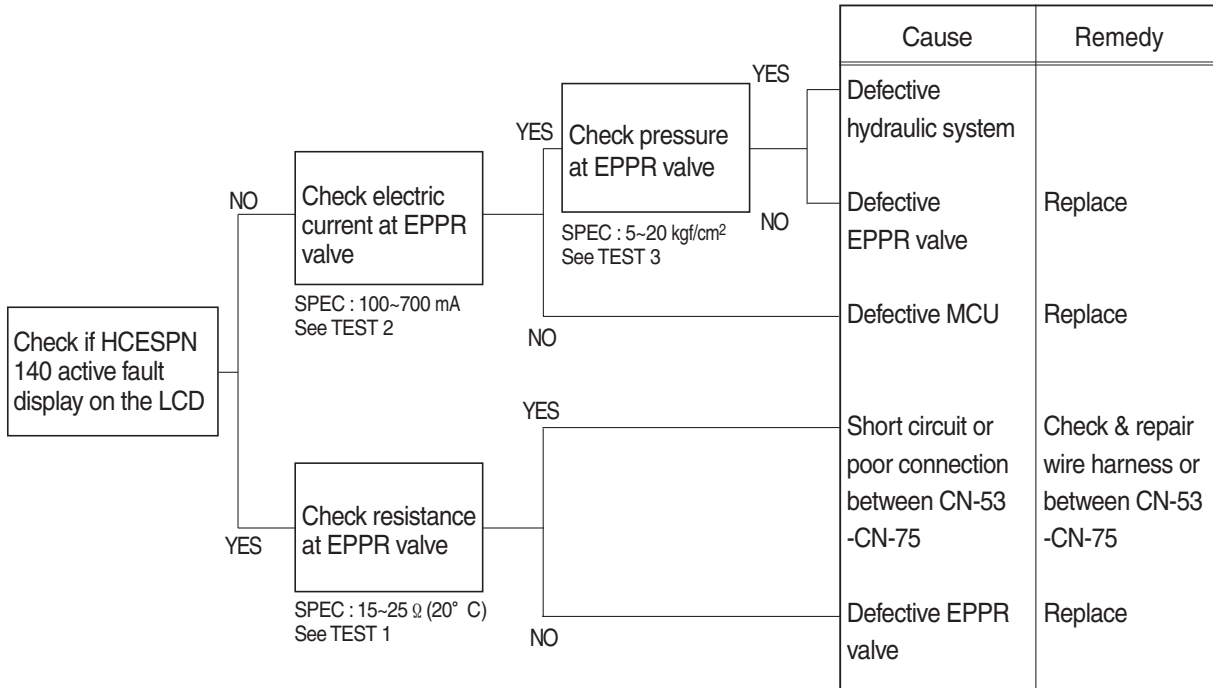

### Wiring diagram

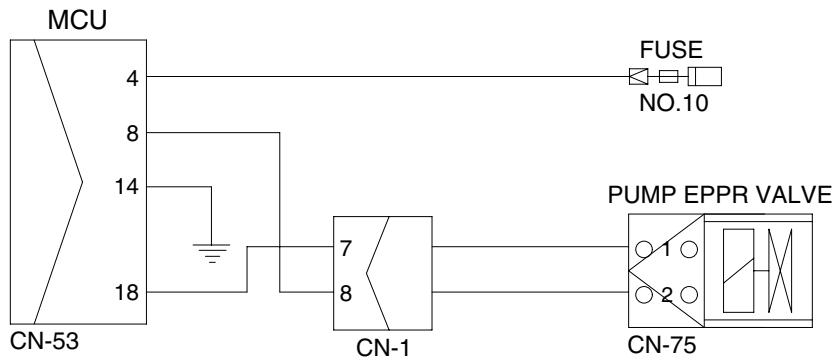

## 2) TEST PROCEDURE

(1) **Test 1** : Check resistance at connector CN-75.

- ① Starting key OFF.
- ② Disconnect connector CN-75 from EPPR valve at main hydraulic pump.
- ③ Check resistance between 2 lines as figure.

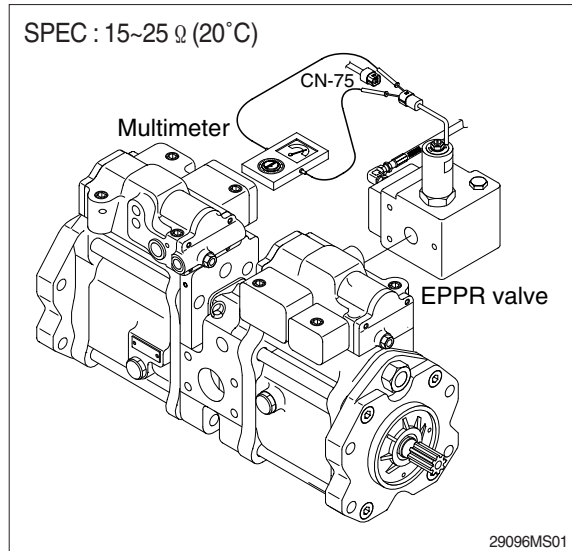

(2) **Test 2** : Check electric current at EPPR valve.

- ① Disconnect connector CN-75 from EPPR valve.
- ② Insert the adapter to CN-75 and install multimeter as figure.
- ③ Start engine.
- ④ Set S-mode and cancel auto decel mode.
- ⑤ Position the accel dial at 10.
- ⑥ If rpm show approx  $1750 \pm 50$  rpm disconnect one wire harness from EPPR valve.
- ⑦ Check electric current at arm circuit relief position.

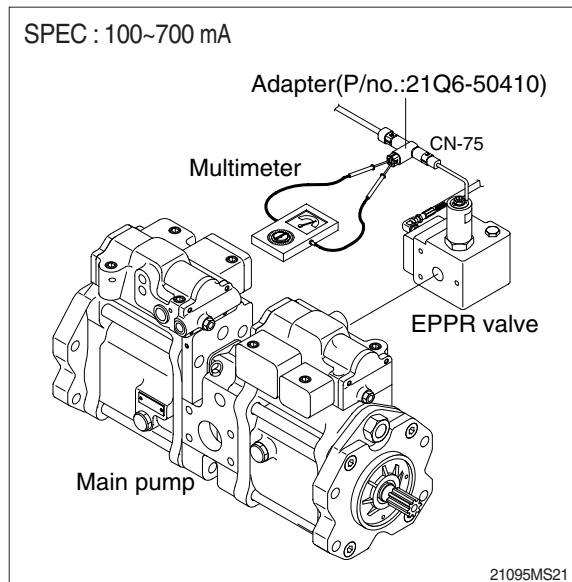

(3) **Test 3** : Check pressure at EPPR valve.

- ① Remove plug and connect pressure gauge as figure.
  - Gauge capacity : 0 to 50 kgf/cm<sup>2</sup>  
(0 to 710 psi)
- ② Start engine.
- ③ Set the accel dial at "10" (Max).
- ④ Set S-mode and cancel auto decel mode.
- ⑤ If rpm show approx  $1750 \pm 50$  rpm, check pressure at relief position of arm circuit by operating arm control lever.
- ⑥ If pressure is not correct, adjust it.
- ⑦ After adjust, test the machine.

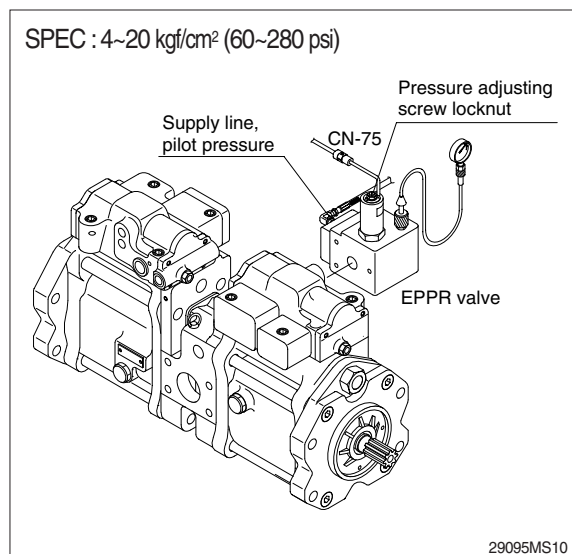

## 2. ENGINE STALL

※ Before carrying out below procedure, check all the related connectors are properly inserted.

### 1) INSPECTION PROCEDURE

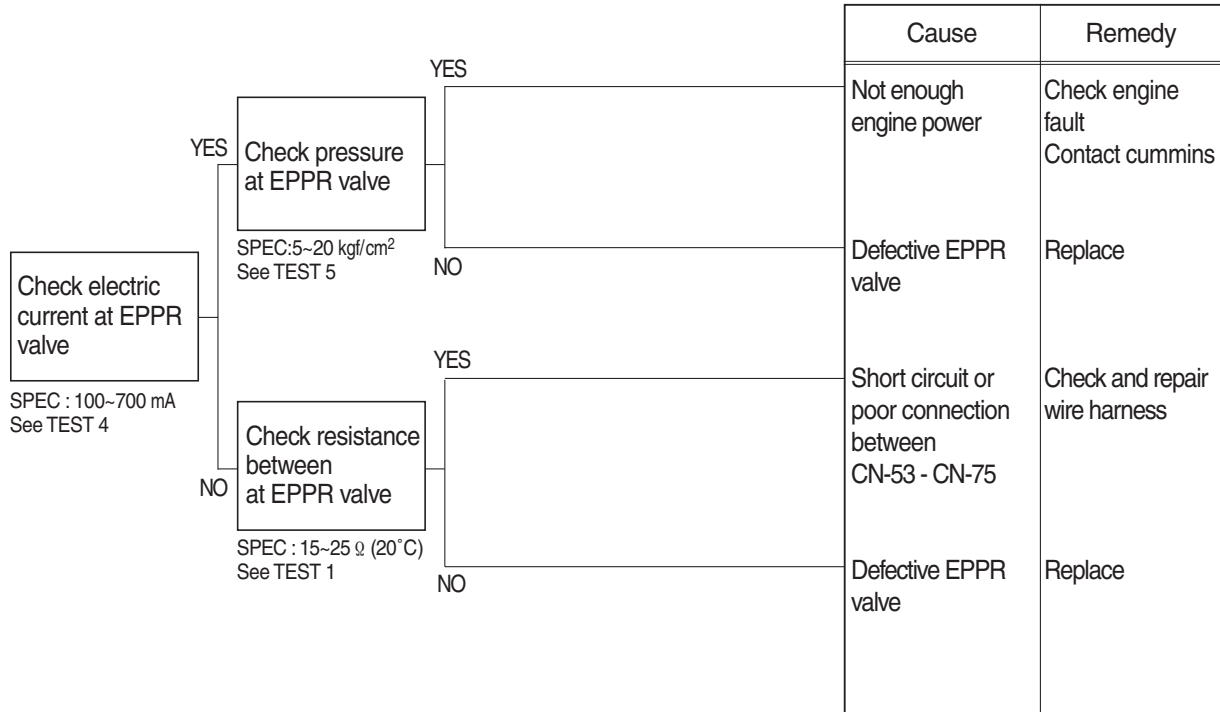

### Wiring diagram

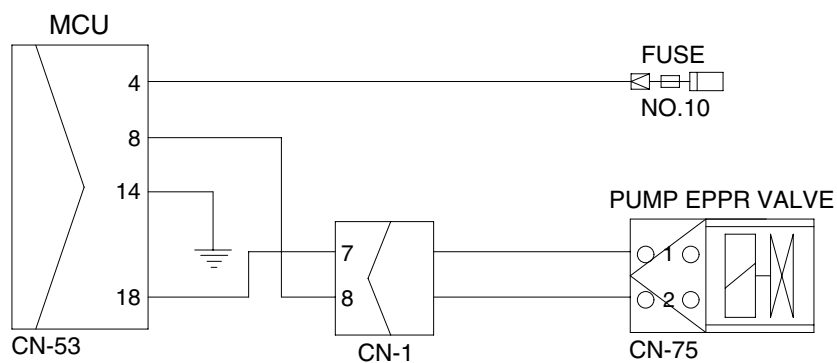

21096MS01

## 2) TEST PROCEDURE

### (1) Test 4 : Check electric current at EPPR valve.

- ① Disconnect connector CN-75 from EPPR valve.
- ② Insert the adapter to CN-75 and install multimeter as figure.
- ③ Start engine.
- ④ Set S-mode and cancel auto decel mode.
- ⑤ Position the accel dial at 10.
- ⑥ If rpm show approx  $1750 \pm 50$  rpm disconnect one wire harness from EPPR valve.
- ⑦ Check electric current at arm circuit relief position.

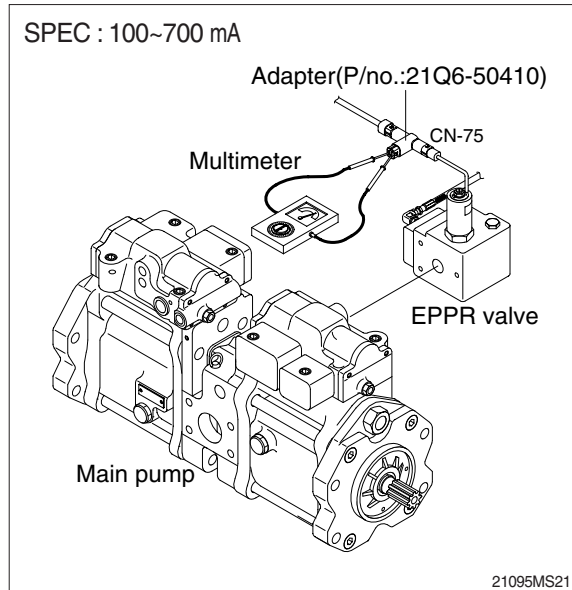

### (2) Test 5 : Check pressure at EPPR valve.

- ① Remove plug and connect pressure gauge as figure.
  - Gauge capacity : 0 to 50 kgf/cm<sup>2</sup>
- ② (0 to 725 psi)
- ③ Start engine.
- ④ Set S-mode and cancel auto decel mode.
- ⑤ Position the accel dial at 10.  
If rpm show approx  $1750 \pm 50$  rpm check pressure at relief position of arm circuit by operating arm control lever.
- ⑥ If pressure is not correct, adjust it.
- ⑦ After adjust, test the machine.

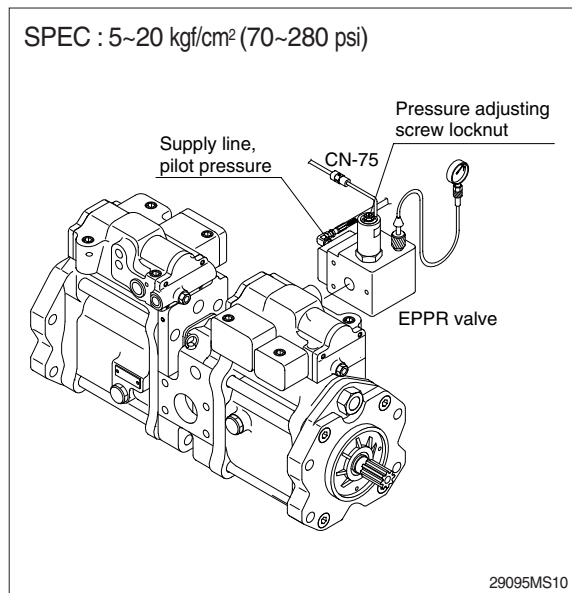

### 3. MALFUNCTION OF CLUSTER OR MODE SELECTION SYSTEM

※ Before carrying out below procedure, check all the related connectors are properly inserted.

#### 1) INSPECTION PROCEDURE

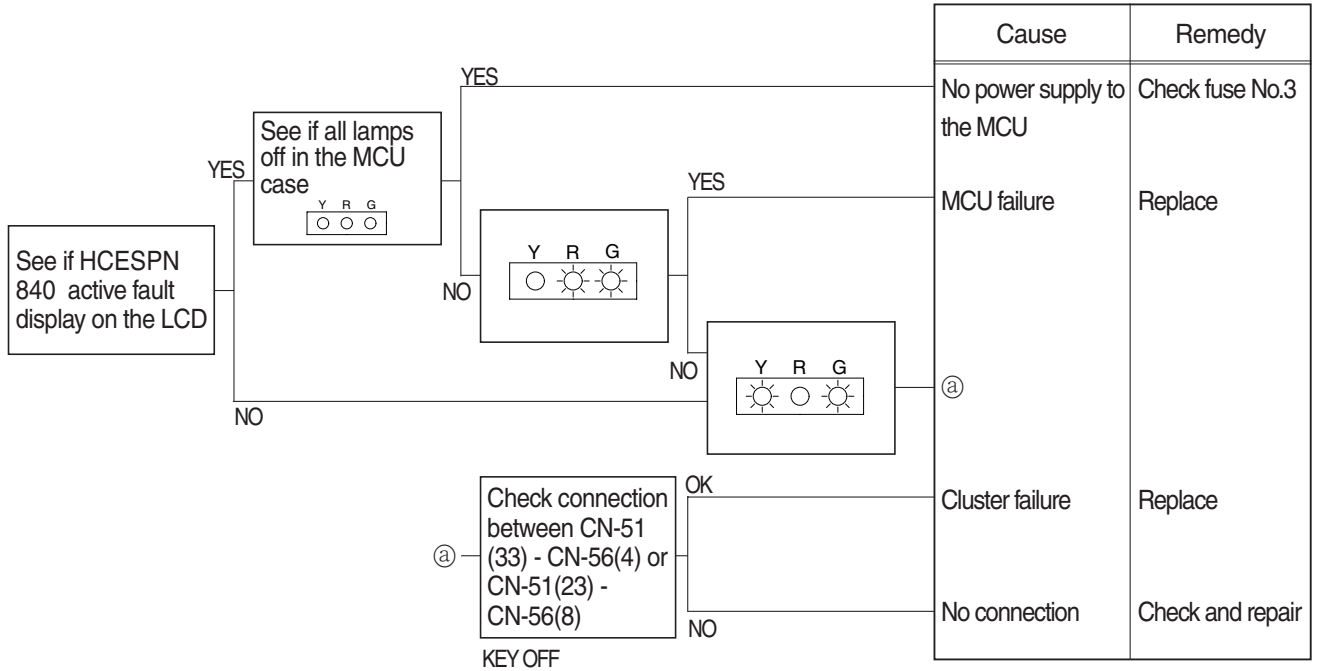

#### Wiring diagram

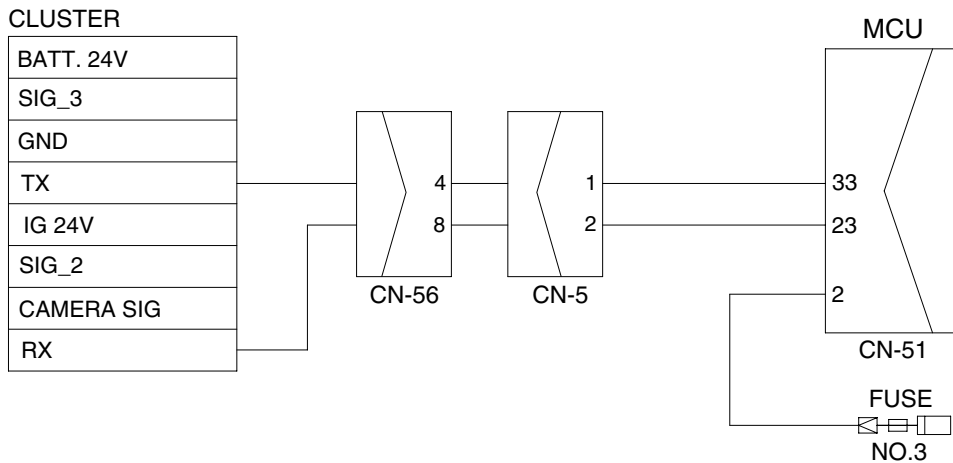

21096MS03

#### 4. MALFUNCTION OF ACCEL DIAL

※ Before carrying out below procedure, check all the related connectors are properly inserted.

##### 1) INSPECTION PROCEDURE

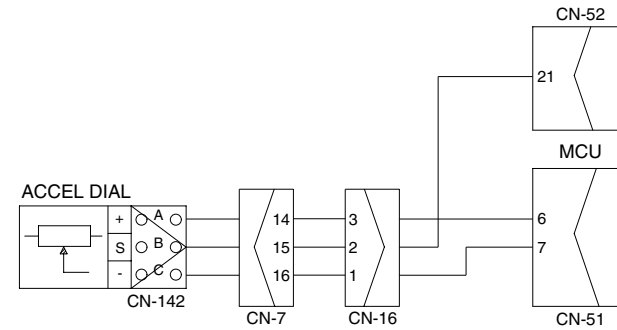
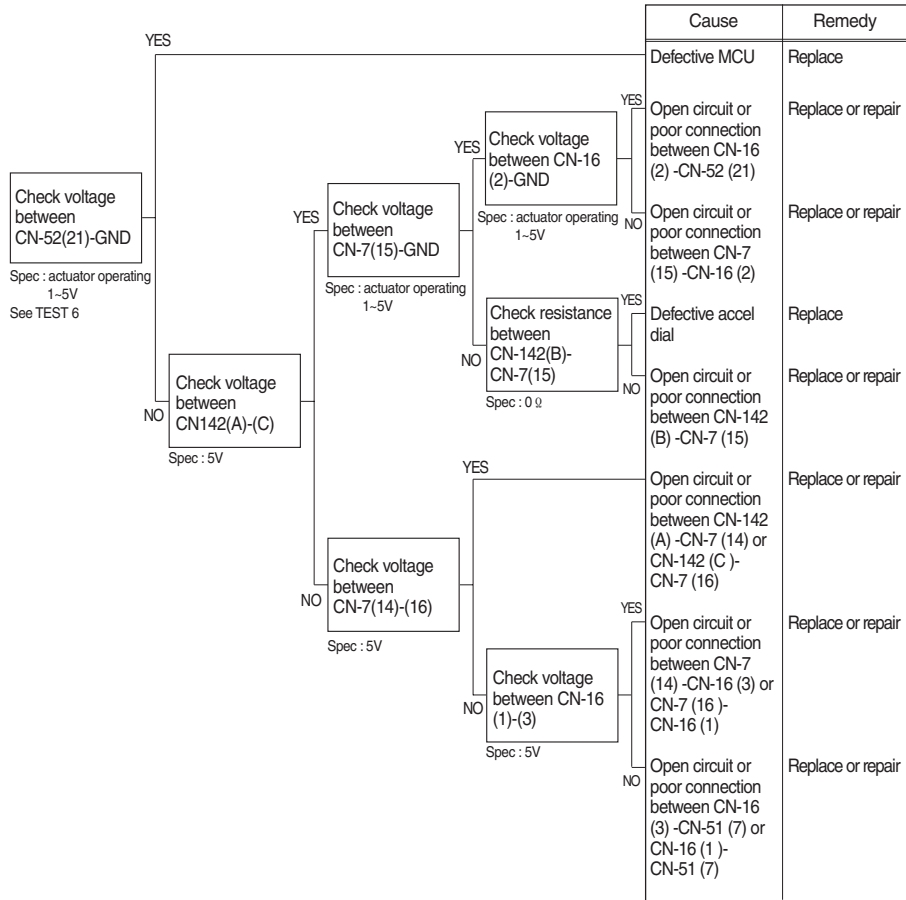

## 2) TEST PROCEDURE

(1) **Test 6** : Check voltage at CN-52(21) and ground.

- ① Prepare 1 piece of thin sharp pin, steel or copper.
- ② Insert prepared pin to rear side of connectors : One pin to (21) of CN-52.
- ③ Starting key ON.
- ④ Check voltage as figure.

SPEC : Actuator operating : 1~5 V

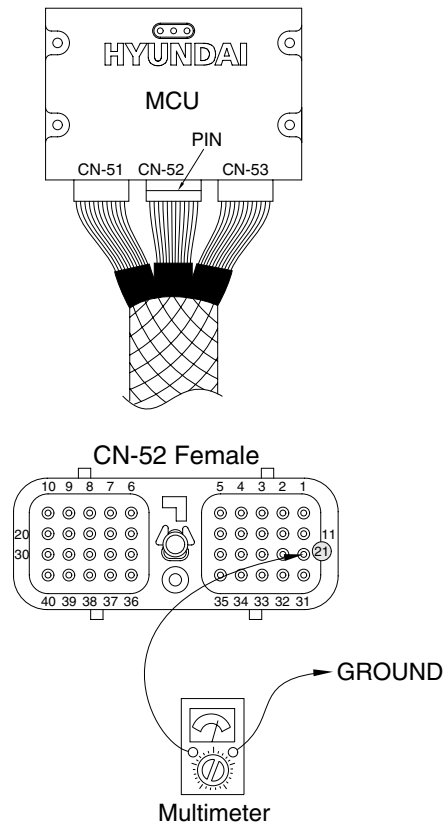

21096MS04A

## 5. AUTO DECEL SYSTEM DOES NOT WORK

- Fault code : HCESPN 105, FMI 0~4 (work pressure sensor)  
HCESPN 108, FMI 0~4 (travel oil pressure sensor)

※ Before carrying out below procedure, check all the related connectors are properly inserted.

### 1) INSPECTION PROCEDURE

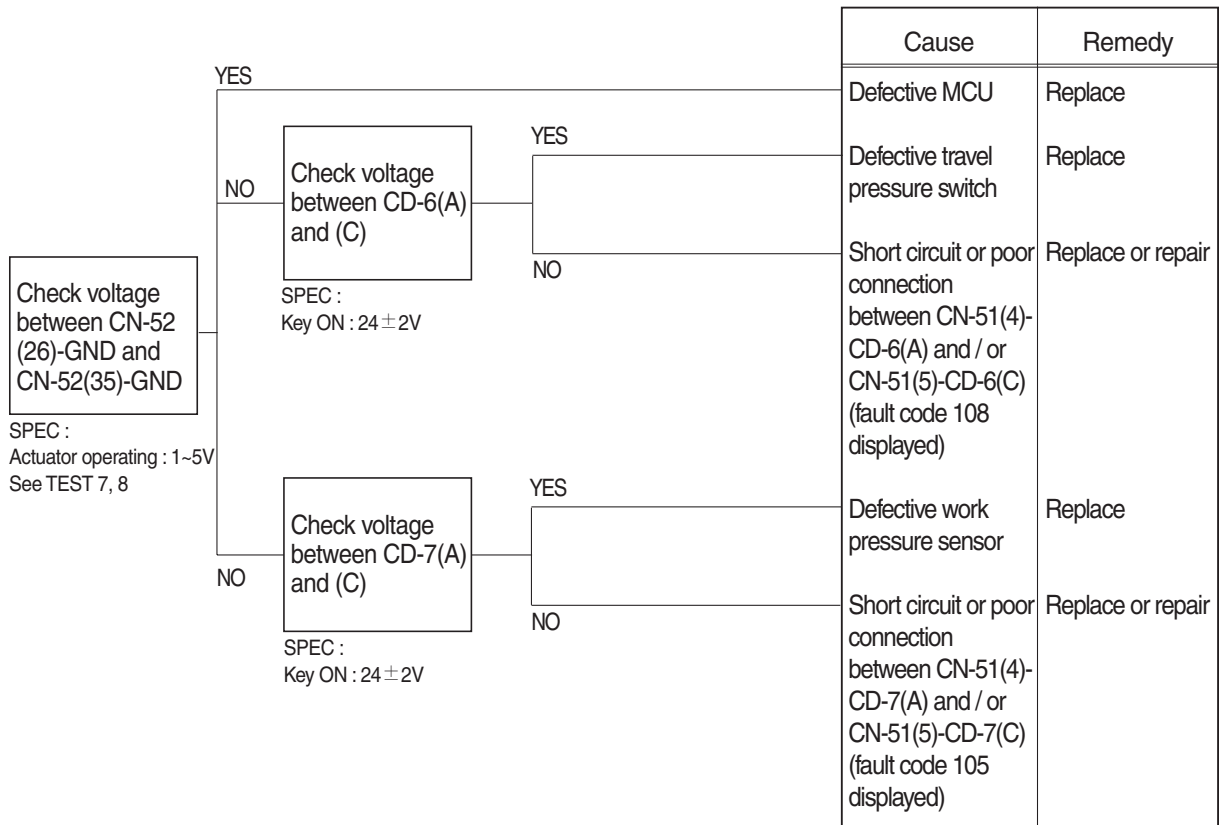

### Wiring diagram

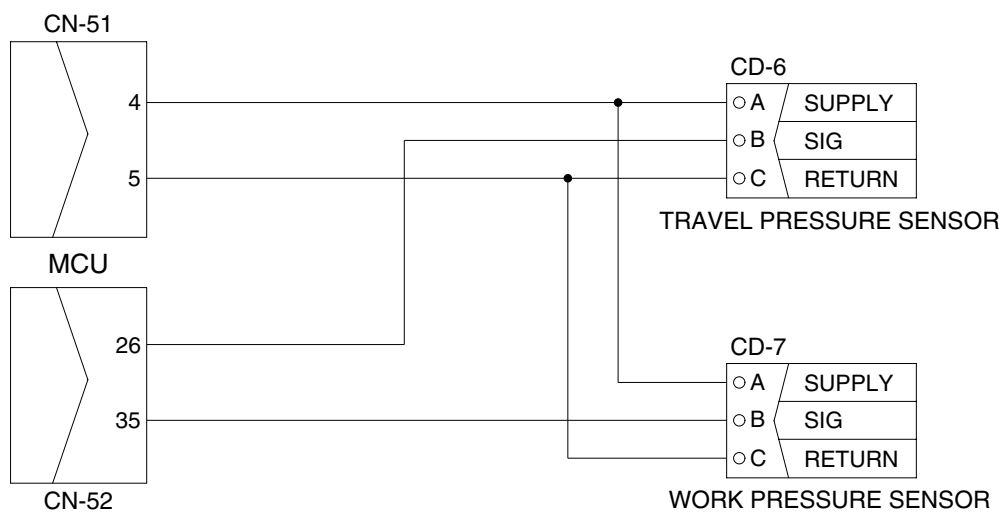

21096MS05



## 2) TEST PROCEDURE

(1) **Test 7** : Check voltage at CN-52(26) and ground.

- ① Prepare 1 piece of thin sharp pin, steel or copper.
- ② Insert prepared pin to rear side of connectors : One pin to (26) of CN-52.
- ③ Starting key ON.
- ④ Check voltage as figure.

(2) **Test 8** : Check voltage at CN-52(35) and ground.

- ① Prepare 1 piece of thin sharp pin, steel or copper
- ② Insert prepared pin to rear side of connectors : One pin to (35) of CN-52.
- ③ Starting key ON.
- ④ Check voltage as figure.

SPEC : Actuator operating : 1~5 V

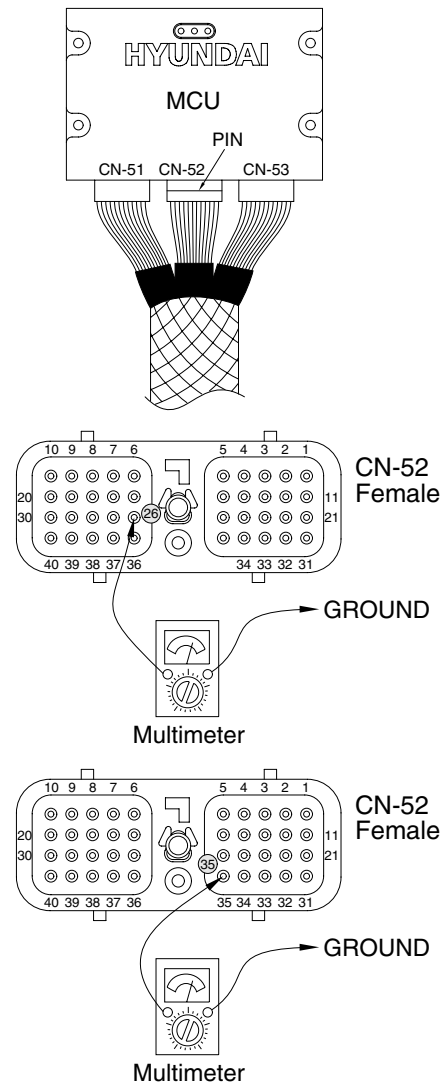

21096MS05A

## 6. MALFUNCTION OF PUMP 1 PRESSURE SENSOR

· Fault code : HCESPN 120, FMI 0~4

※ Before carrying out below procedure, check all the related connectors are properly inserted.

### 1) INSPECTION PROCEDURE

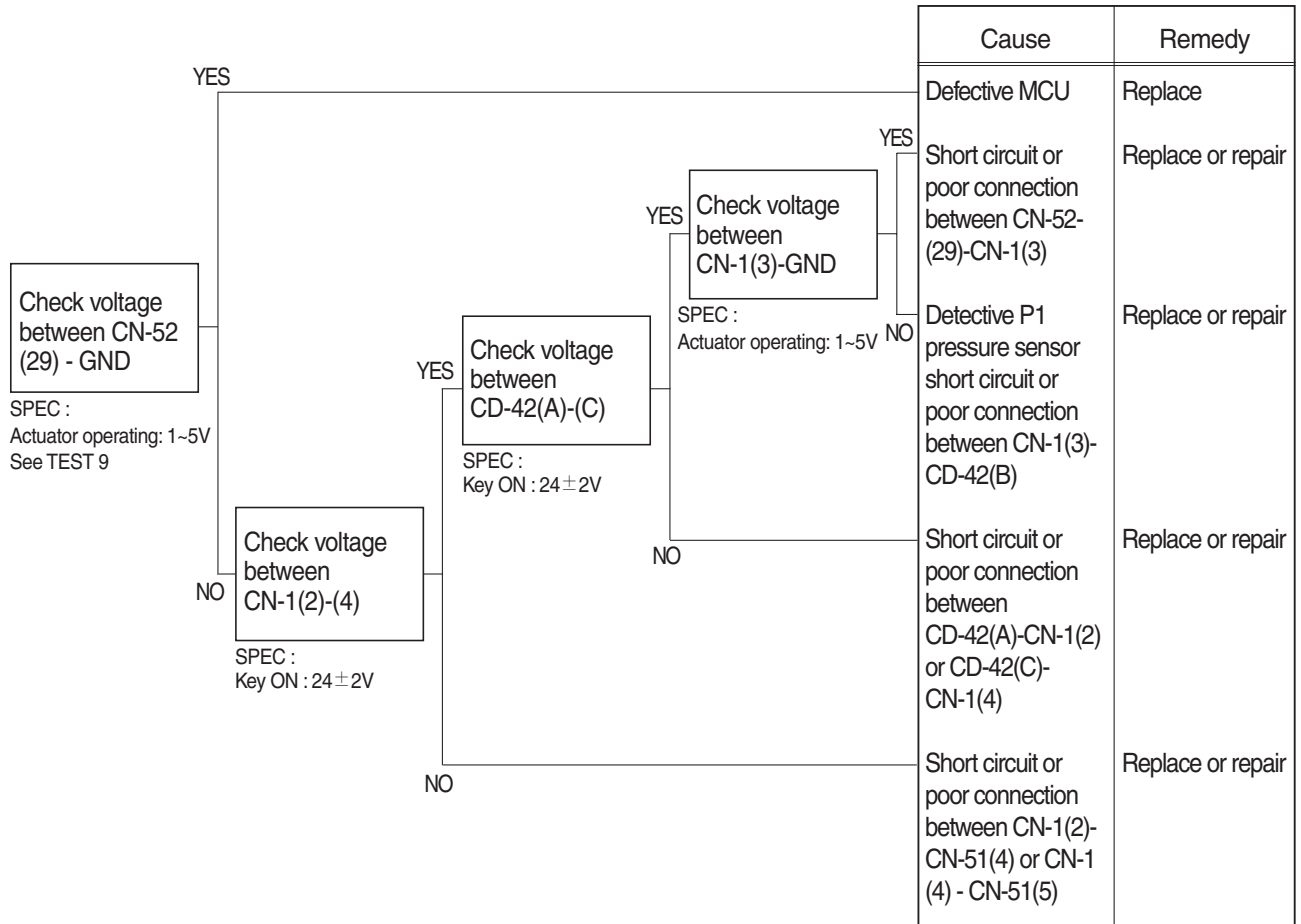

### Wiring diagram

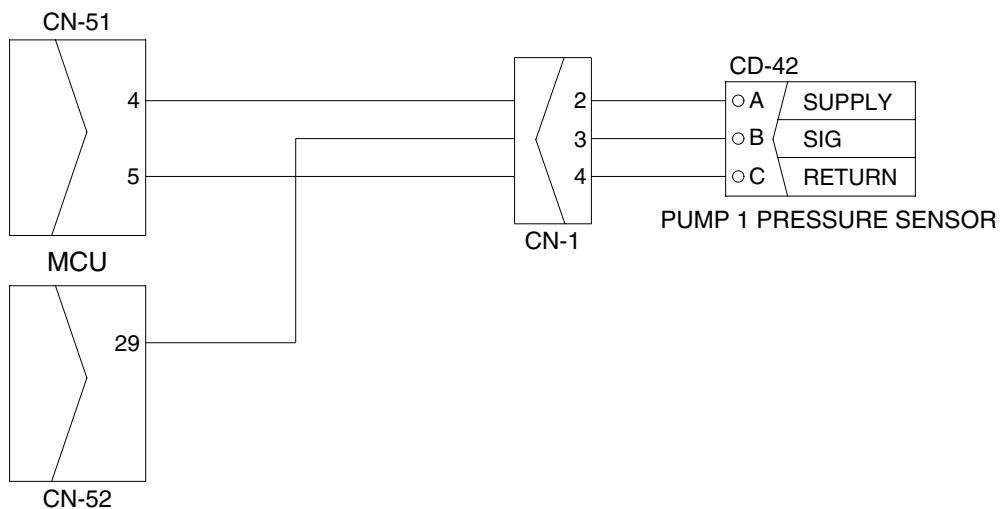

## 2) TEST PROCEDURE

(1) **Test 9** : Check voltage at CN-52(29) and ground.

- ① Prepare 1 piece of thin sharp pin, steel or copper.
- ② Insert prepared pin to rear side of connectors : One pin to (29) of CN-52.
- ③ Starting key ON.
- ④ Check voltage as figure.

SPEC : Actuator operating : 1~5 V

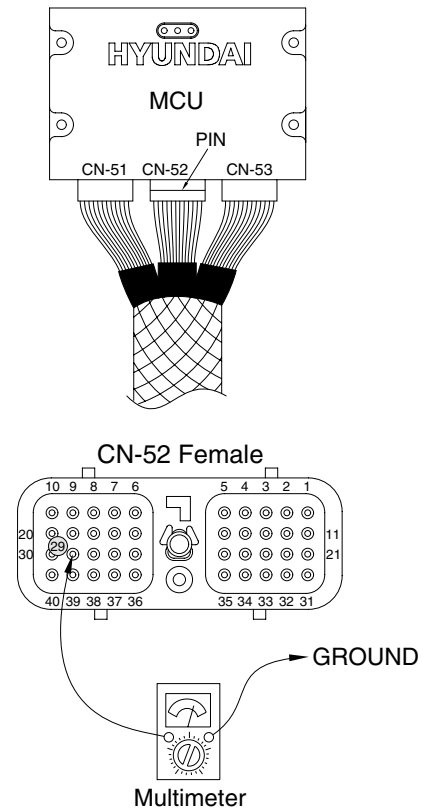

21096MS06A

## 7. MALFUNCTION OF PUMP 2 PRESSURE SENSOR

· Fault code : HCESPN 121, FMI 0~4

※ Before carrying out below procedure, check all the related connectors are properly inserted.

### 1) INSPECTION PROCEDURE

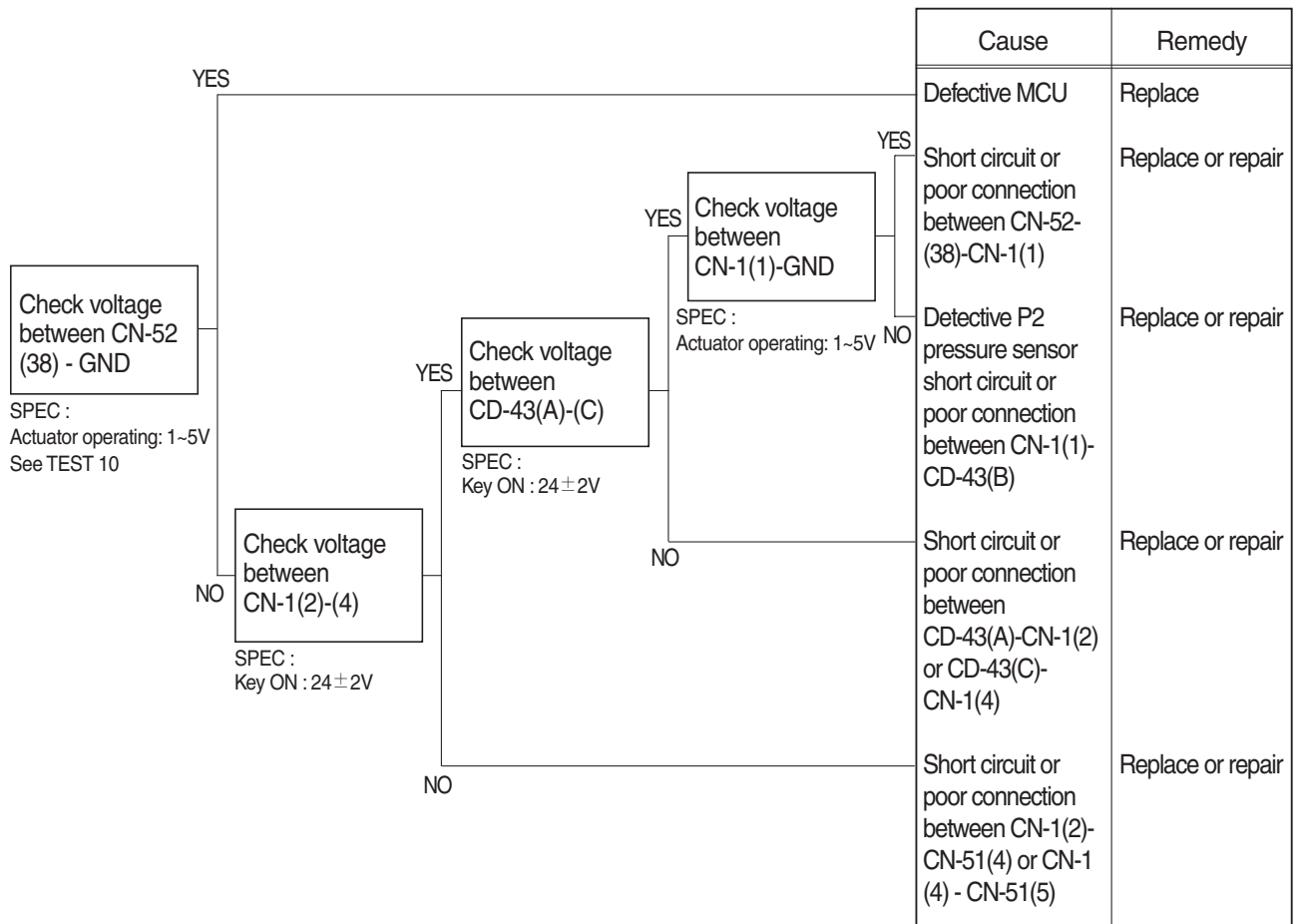

### Wiring diagram

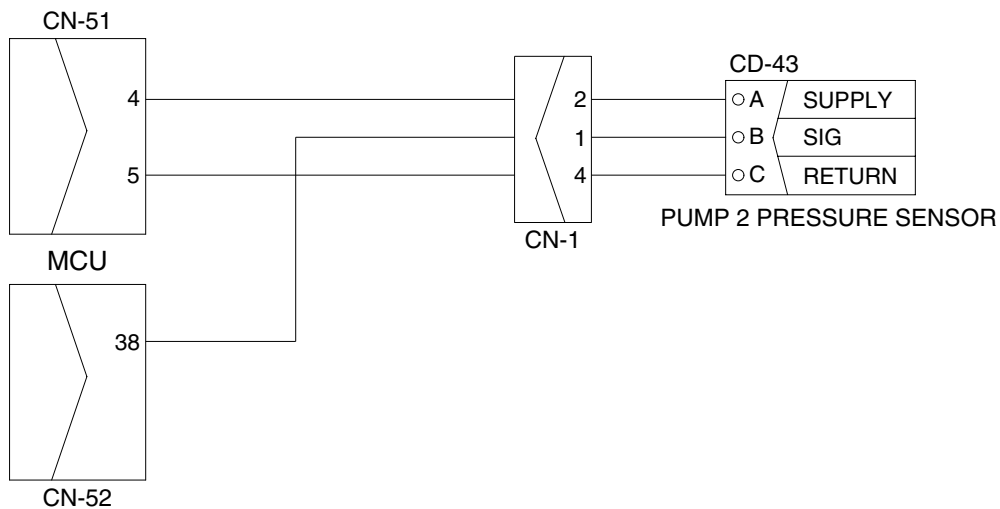

## 2) TEST PROCEDURE

(1) Test 10 : Check voltage at CN-52(38) and ground.

- ① Prepare 1 piece of thin sharp pin, steel or copper.
- ② Insert prepared pin to rear side of connectors : One pin to (38) of CN-52.
- ③ Starting key ON.
- ④ Check voltage as figure.

SPEC : Actuator operating : 1~5 V

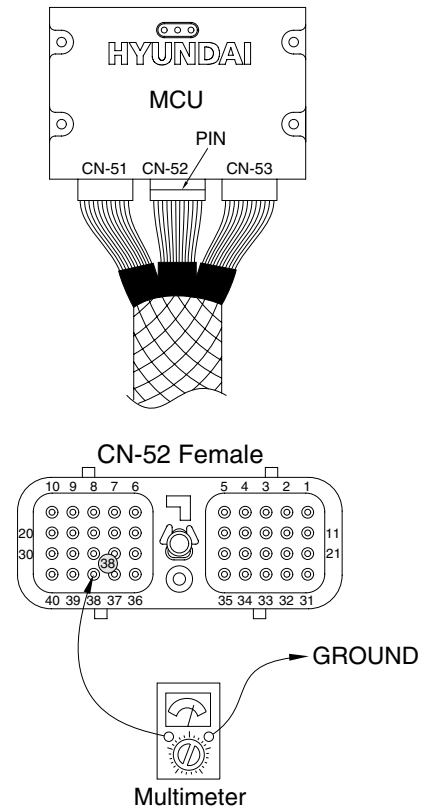

21096MS07A

## 8. MALFUNCTION OF PUMP 3 PRESSURE SENSOR

· Fault code : HCESPN 125, FMI 0~4

※ Before carrying out below procedure, check all the related connectors are properly inserted.

### 1) INSPECTION PROCEDURE

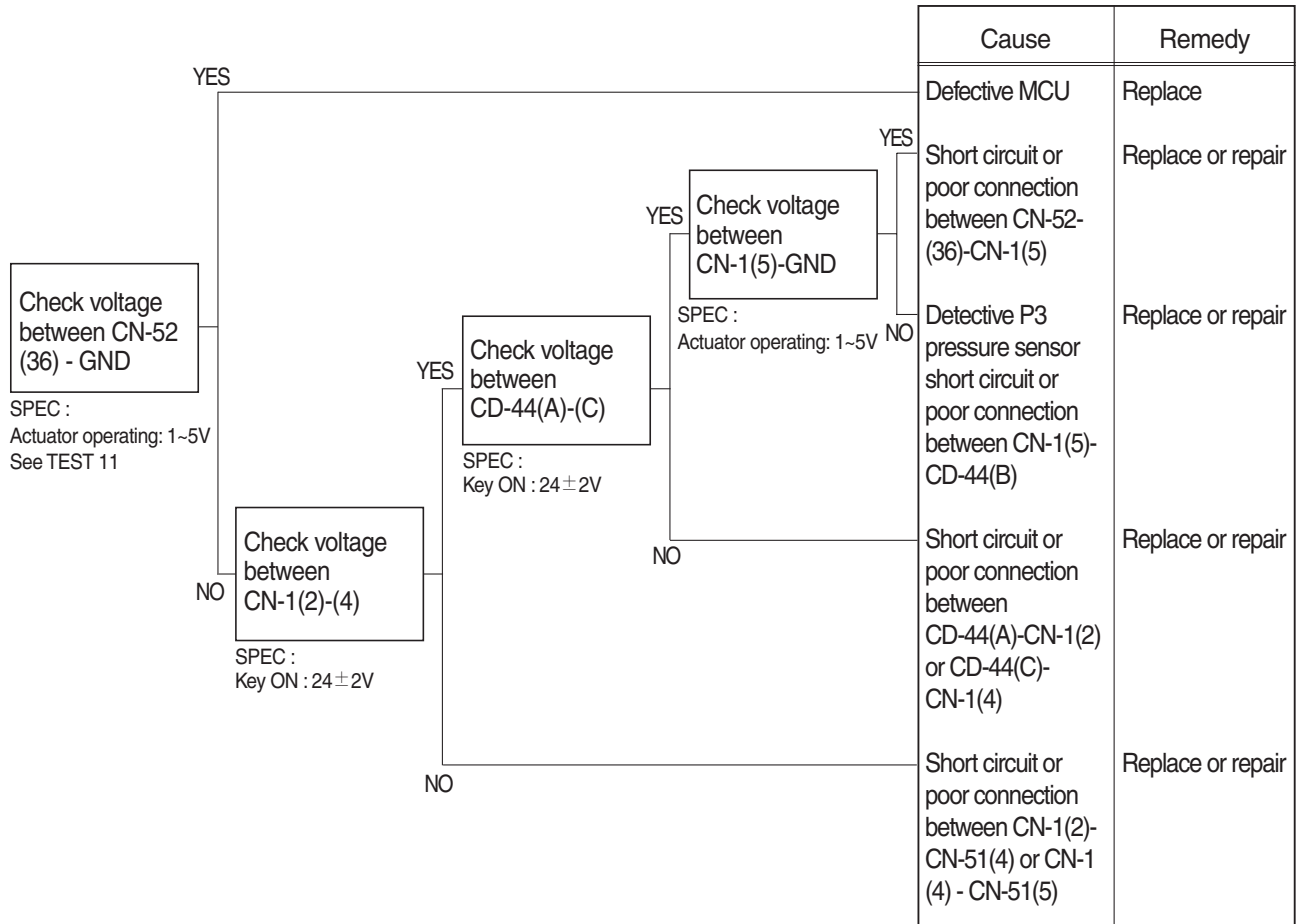

### Wiring diagram

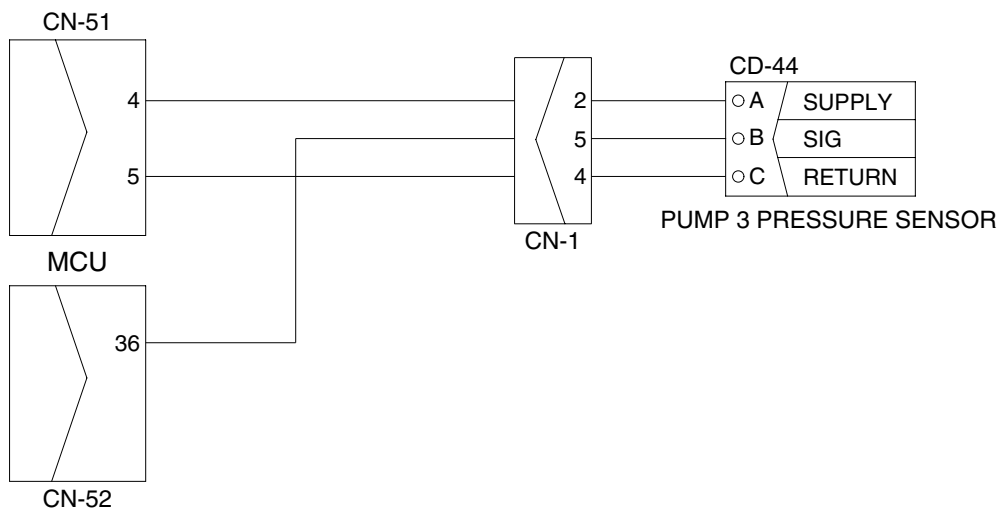

21096MS08

## 2) TEST PROCEDURE

(1) **Test 11** : Check voltage at CN-52(36) and ground.

- ① Prepare 1 piece of thin sharp pin, steel or copper.
- ② Insert prepared pin to rear side of connectors : One pin to (36) of CN-52.
- ③ Starting key ON.
- ④ Check voltage as figure.

SPEC : Actuator operating : 1~5 V

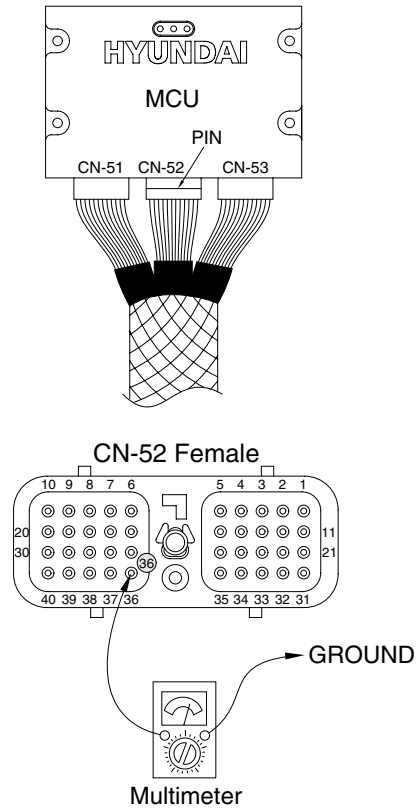

21096MS08A

## 9. MALFUNCTION OF NEGATIVE 1 PRESSURE SENSOR

· Fault code : HCESPN 123, FMI 0~4

※ Before carrying out below procedure, check all the related connectors are properly inserted.

### 1) INSPECTION PROCEDURE

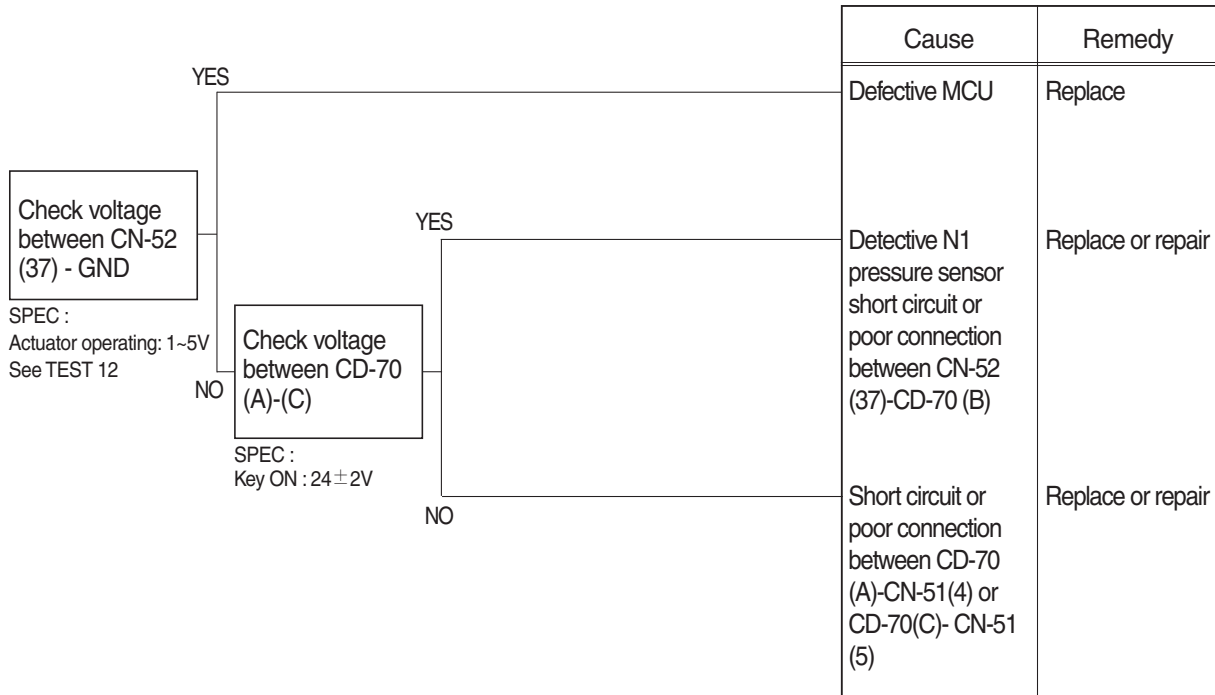

### Wiring diagram

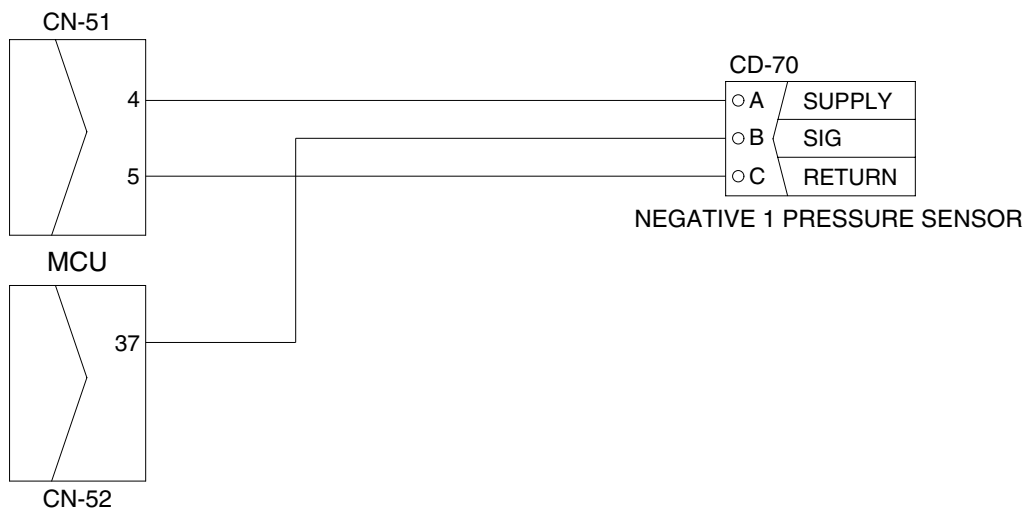

21096MS09



## 2) TEST PROCEDURE

(1) **Test 12** : Check voltage at CN-52(37) and ground.

- ① Prepare 1 piece of thin sharp pin, steel or copper.
- ② Insert prepared pin to rear side of connectors : One pin to (37) of CN-52.
- ③ Starting key ON.
- ④ Check voltage as figure.

SPEC : Actuator operating : 1~5 V

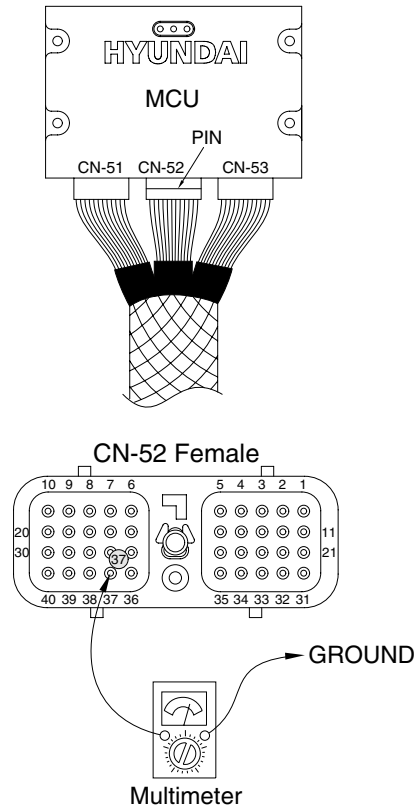

21096MS09A

## 10. MALFUNCTION OF NEGATIVE 2 PRESSURE SENSOR

· Fault code : HCESPN 124, FMI 0~4

※ Before carrying out below procedure, check all the related connectors are properly inserted.

### 1) INSPECTION PROCEDURE

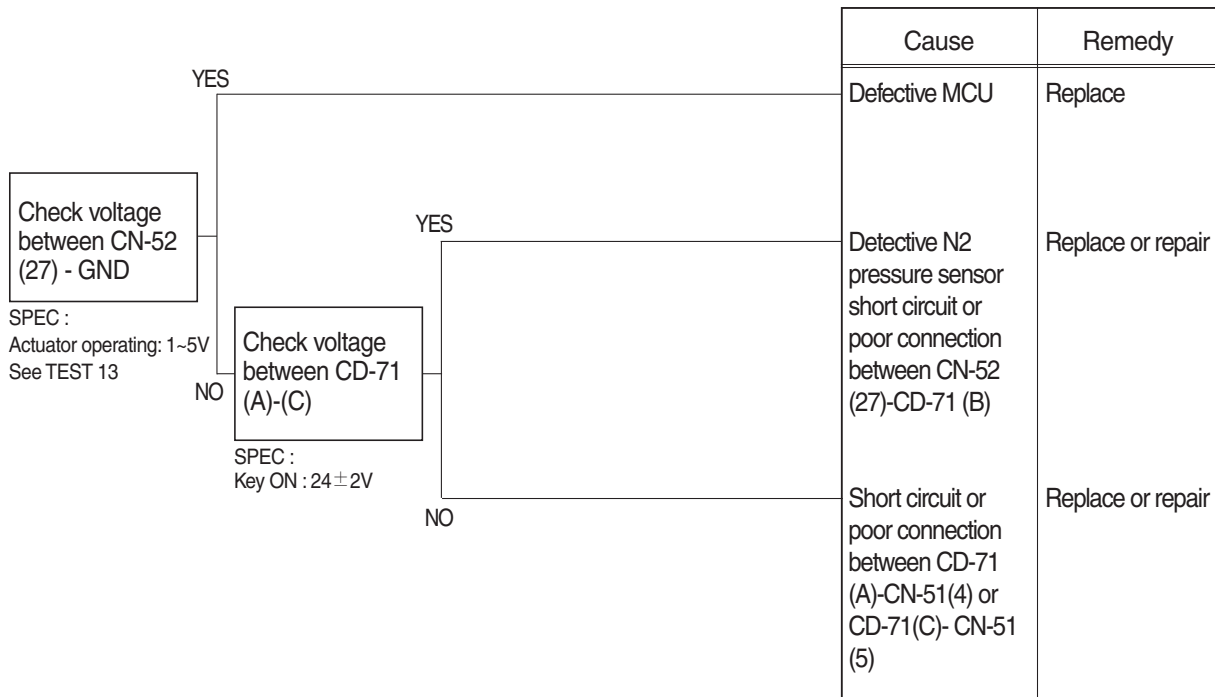

### Wiring diagram

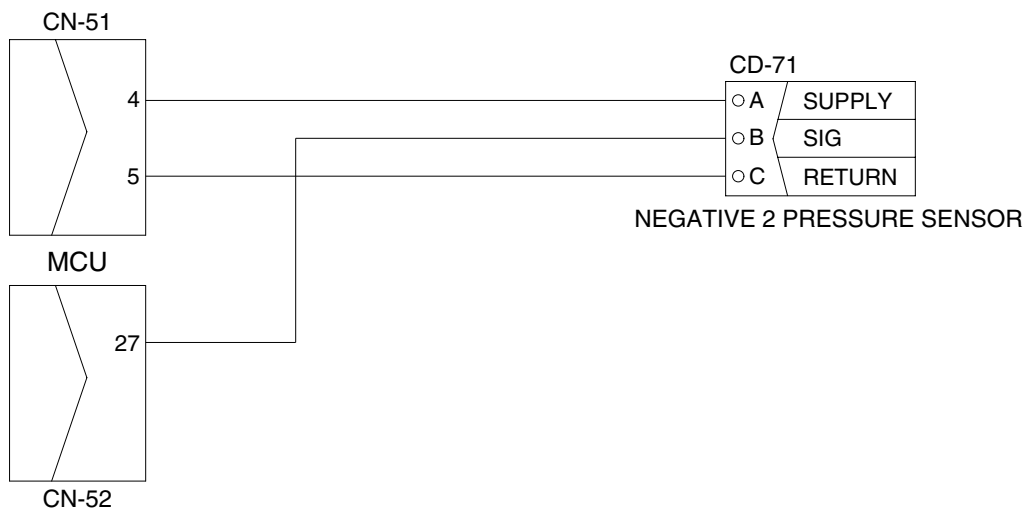

21096MS10

## 2) TEST PROCEDURE

(1) **Test 13** : Check voltage at CN-52(27) and ground.

- ① Prepare 1 piece of thin sharp pin, steel or copper.
- ② Insert prepared pin to rear side of connectors : One pin to (27) of CN-52.
- ③ Starting key ON.
- ④ Check voltage as figure.

SPEC : Actuator operating : 1~5 V

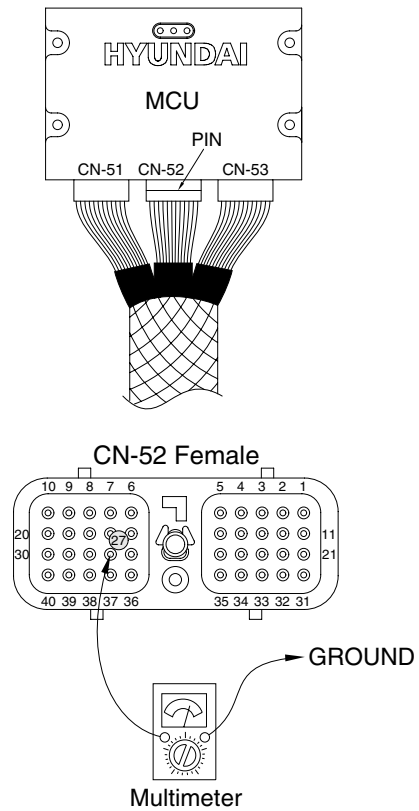

21096MS10A

## 11. MALFUNCTION OF SWING PRESSURE SENSOR

· Fault code : HCESPN 135, FMI 0~4

※ Before carrying out below procedure, check all the related connectors are properly inserted.

### 1) INSPECTION PROCEDURE

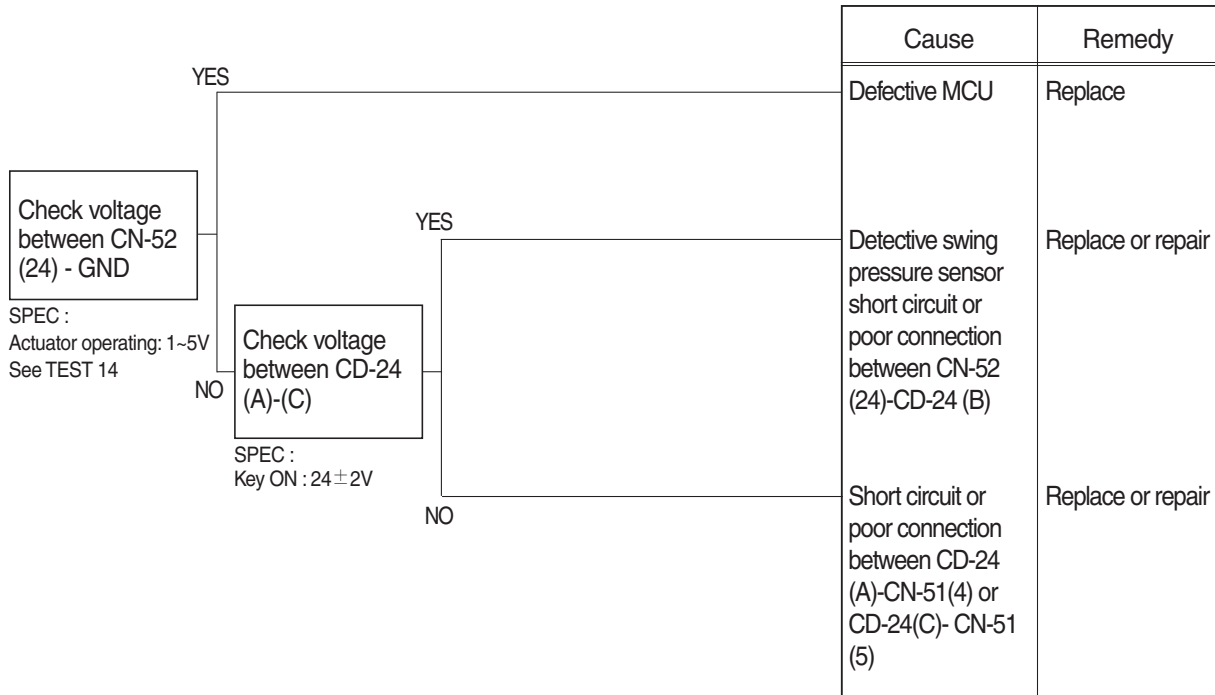

### Wiring diagram

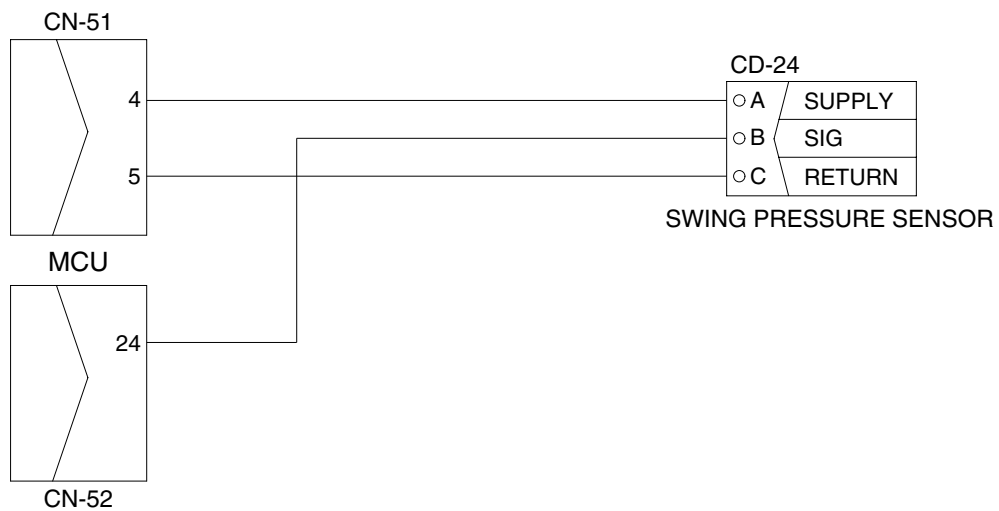

21096MS11

## 2) TEST PROCEDURE

(1) Test 14 : Check voltage at CN-52(24) and ground.

- ① Prepare 1 piece of thin sharp pin, steel or copper.
- ② Insert prepared pin to rear side of connectors : One pin to (24) of CN-52.
- ③ Starting key ON.
- ④ Check voltage as figure.

SPEC : Actuator operating : 1~5 V

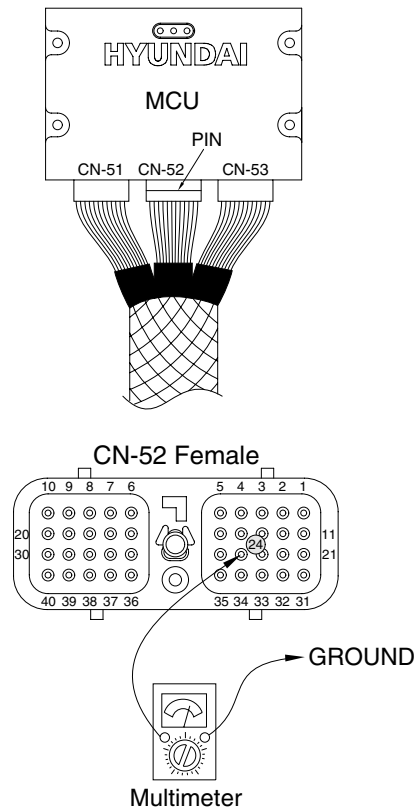

21096MS11A

## 12. MALFUNCTION OF ARM IN/OUT PRESSURE SENSOR

· Fault code : HCESPN 133, FMI 0~4

※ Before carrying out below procedure, check all the related connectors are properly inserted.

### 1) INSPECTION PROCEDURE

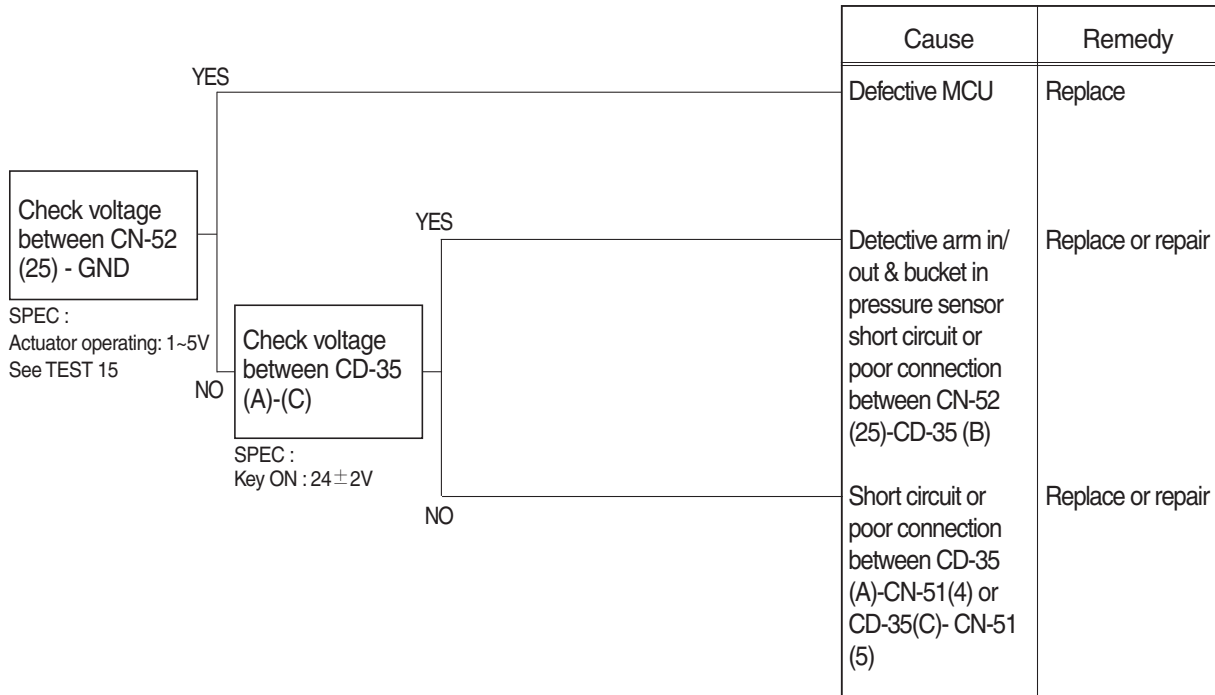

### Wiring diagram

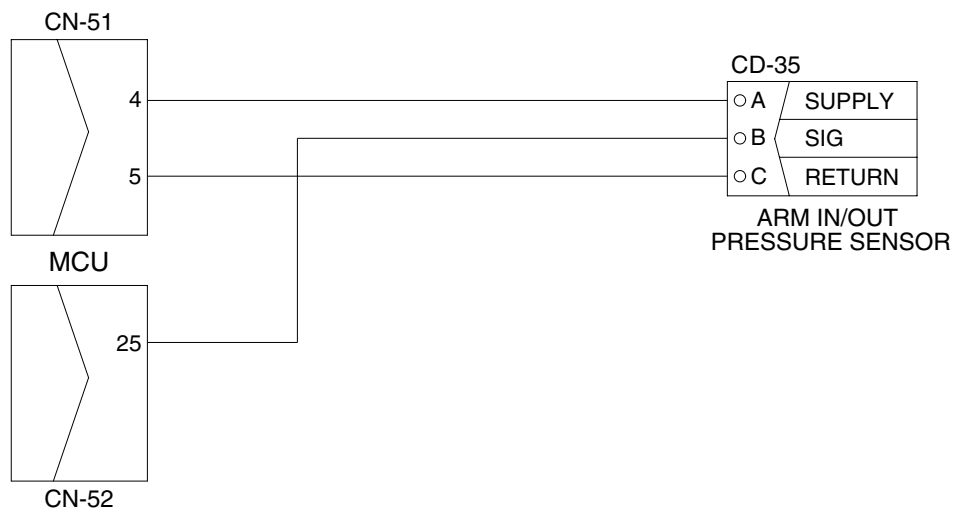

4809MH6MS02

## 2) TEST PROCEDURE

(1) **Test 15** : Check voltage at CN-52(25) and ground.

- ① Prepare 1 piece of thin sharp pin, steel or copper.
- ② Insert prepared pin to rear side of connectors : One pin to (25) of CN-52.
- ③ Starting key ON.
- ④ Check voltage as figure.

SPEC : Actuator operating : 1~5 V

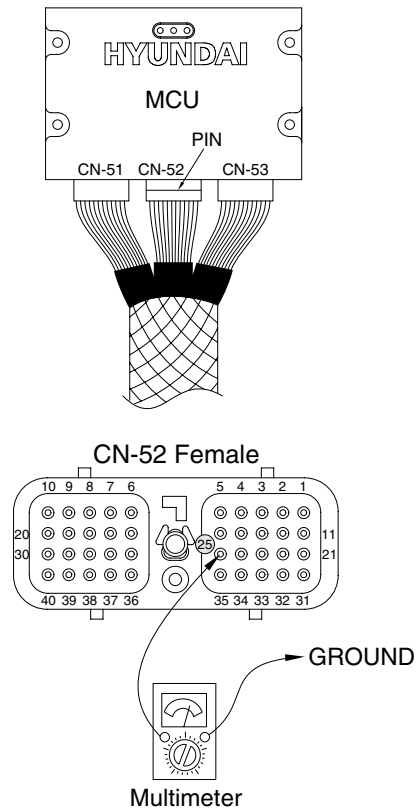

21096MS12A

### 13. MALFUNCTION OF BOOM UP PRESSURE SENSOR

· Fault code : HCESPN 127, FMI 0~4

※ Before carrying out below procedure, check all the related connectors are properly inserted.

#### 1) INSPECTION PROCEDURE

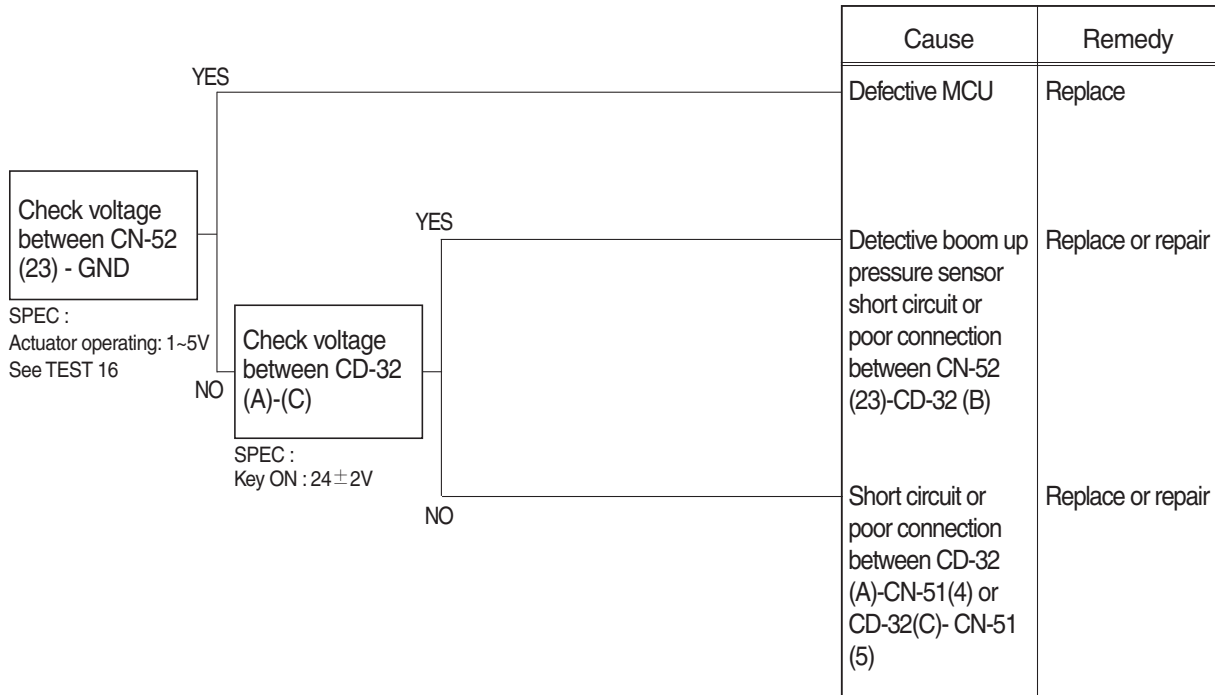

#### Wiring diagram

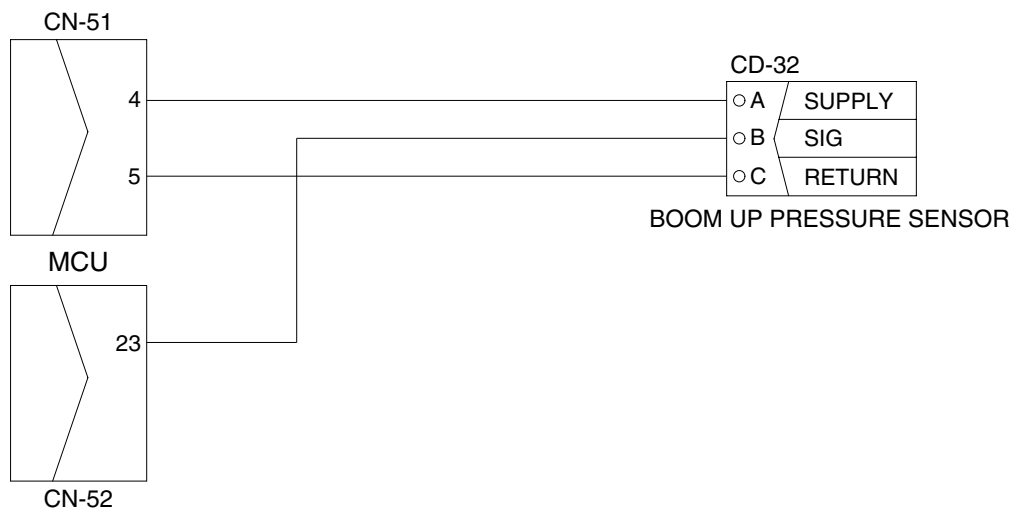

21096MS13



## 2) TEST PROCEDURE

(1) **Test 16** : Check voltage at CN-52(23) and ground.

- ① Prepare 1 piece of thin sharp pin, steel or copper.
- ② Insert prepared pin to rear side of connectors : One pin to (23) of CN-52.
- ③ Starting key ON.
- ④ Check voltage as figure.

SPEC : Actuator operating : 1~5 V

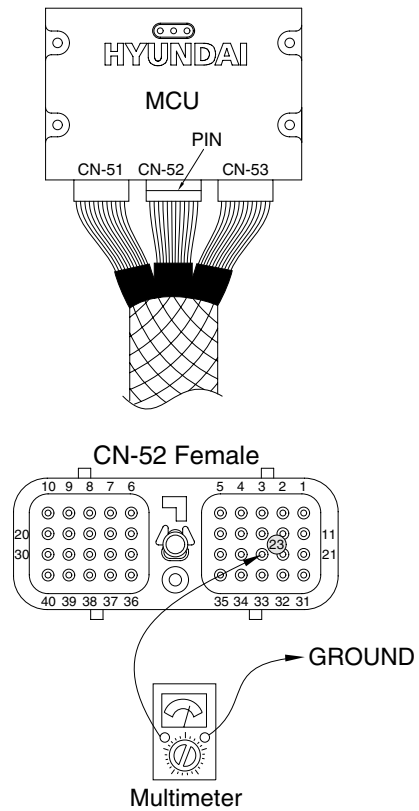

21096MS13A

## 14. MALFUNCTION OF BOOM PRIORITY EPPR VALVE

· Fault code : HCESPN 141, FMI 5 or 6

※ Before carrying out below procedure, check all the related connectors are properly inserted.

### 1) INSPECTION PROCEDURE



### Wiring diagram

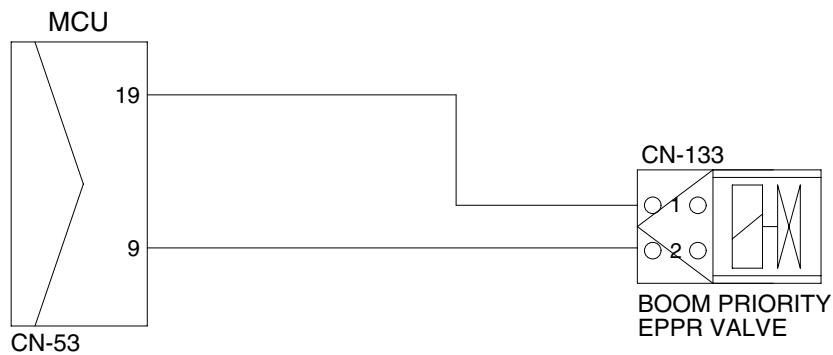

21096MS15