

GROUP 4 MAIN CONTROL VALVE

1. REMOVAL AND INSTALL OF MOTOR

1) REMOVAL

- (1) Lower the work equipment to the ground and stop the engine.
- (2) Operate the control levers and pedals several times to release the remaining pressure in the hydraulic piping.
- (3) Loosen the breather slowly to release the pressure inside the hydraulic tank.

▲ Escaping fluid under pressure can penetrate the skin causing serious injury.

- ※ When pipes and hoses are disconnected, the oil inside the piping will flow out, so catch it in oil pan.
- (4) Remove the wirings for the pressure sensor and so on.
 - (5) Remove bolts and disconnect pipe.
 - (6) Disconnect pilot line hoses.
 - (7) Disconnect pilot piping.
 - (8) Sling the control valve assembly and remove the control valve mounting bolt.
 - Weight : 200 kg (441lb)
 - (9) Remove the control valve assembly.
When removing the control valve assembly, check that all the piping have been disconnected.

2) INSTALL

- (1) Carry out installation in the reverse order to removal.
- (2) Bleed the air from below items.
 - ① Cylinder (boom, arm, bucket)
 - ② Swing motor
 - ③ Travel motor
- ※ See each item removal and install.
- (3) Confirm the hydraulic oil level and recheck the hydraulic oil leak or not.

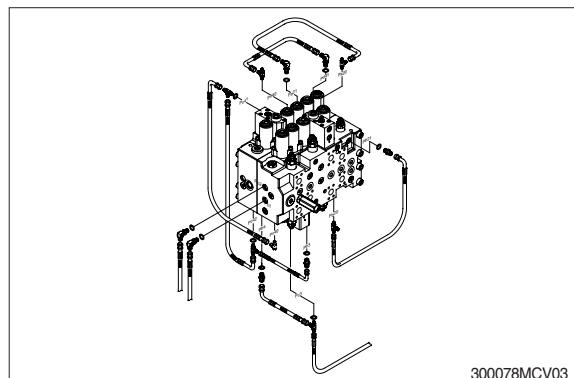
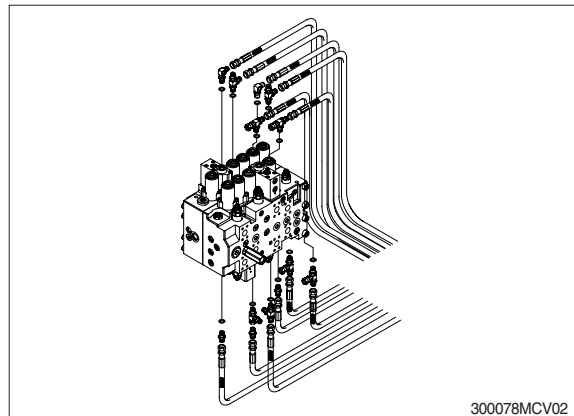
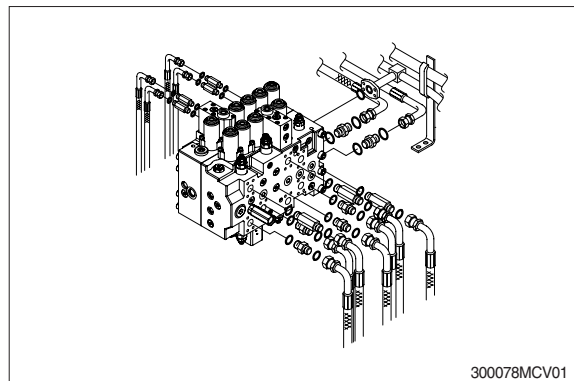

2. STRUCTURE

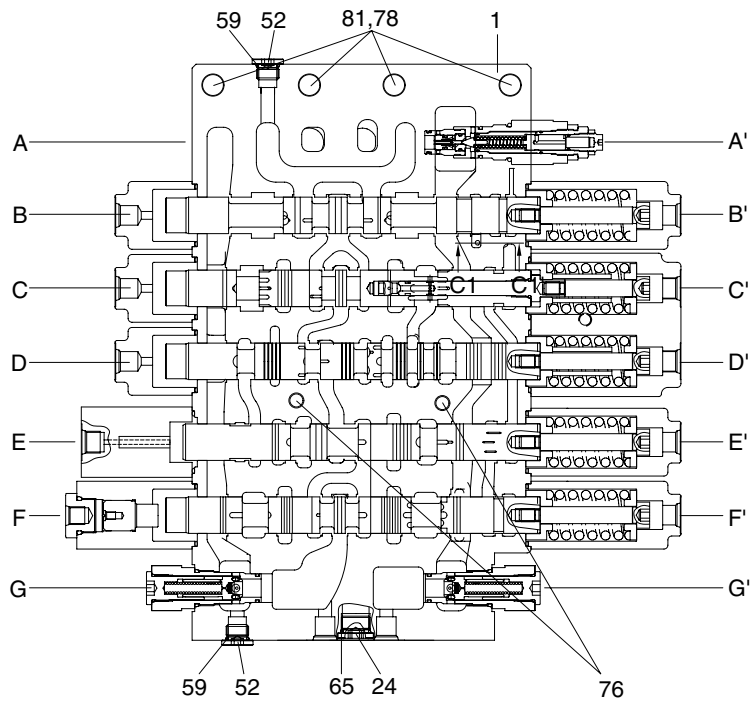

P1 BLOCK SPOOL SECTION

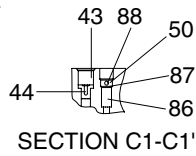

SECTION C1-C1'

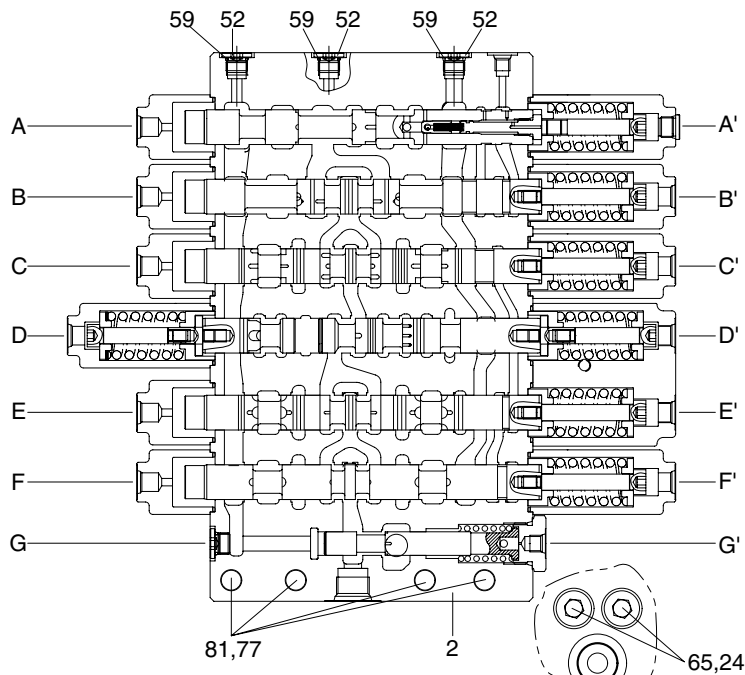

P2 BLOCK SPOOL SECTION

- 1 Housing (P1)
- 2 Housing (P2)
- 24 Plug
- 43 Orifice-signal
- 44 Coin type filter
- 50 O-ring
- 52 Plug
- 59 O-ring
- 65 O-ring
- 76 Socket bolt
- 77 Hex socket head bolt
- 78 Hex socket head bolt
- 81 Spring washer
- 86 Poppet
- 87 Spring check
- 88 Plug

2909MH2MC02

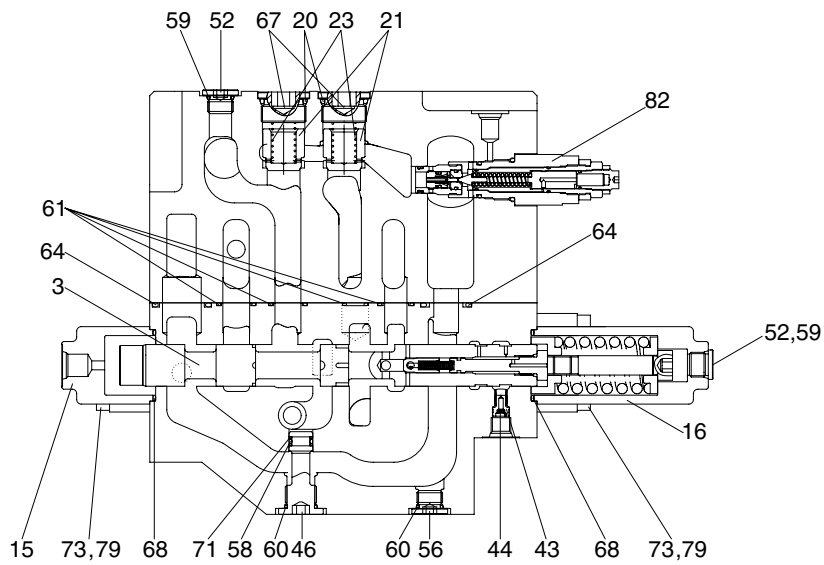

A-A' (STRAIGHT-TRAVEL & SUPPLY)

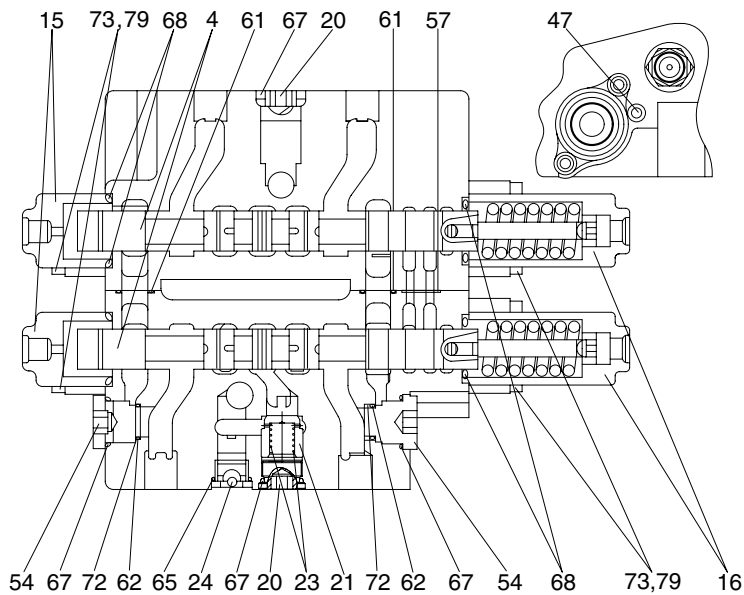

B-B' (TRAVEL RIGHT & LEFT)

- 3 Spool-straight
- 4 Spool-travel
- 15 Cover-pilot A
- 16 Cover-pilot B1
- 20 Plug
- 21 Poppet 1-check valve
- 23 Spring 1-check valve
- 24 Plug
- 43 Orifice-signal
- 44 Coin type filter
- 46 Plug
- 47 Plug
- 52 Plug
- 54 Plug
- 56 Plug
- 57 O-ring
- 58 O-ring
- 59 O-ring
- 60 O-ring
- 61 O-ring
- 62 O-ring
- 64 O-ring
- 65 O-ring
- 67 O-ring
- 68 O-ring
- 71 Back-up ring
- 72 Back-up ring
- 73 Hex socket head bolt
- 79 Washer
- 82 Main relief valve

2909MH2MC03

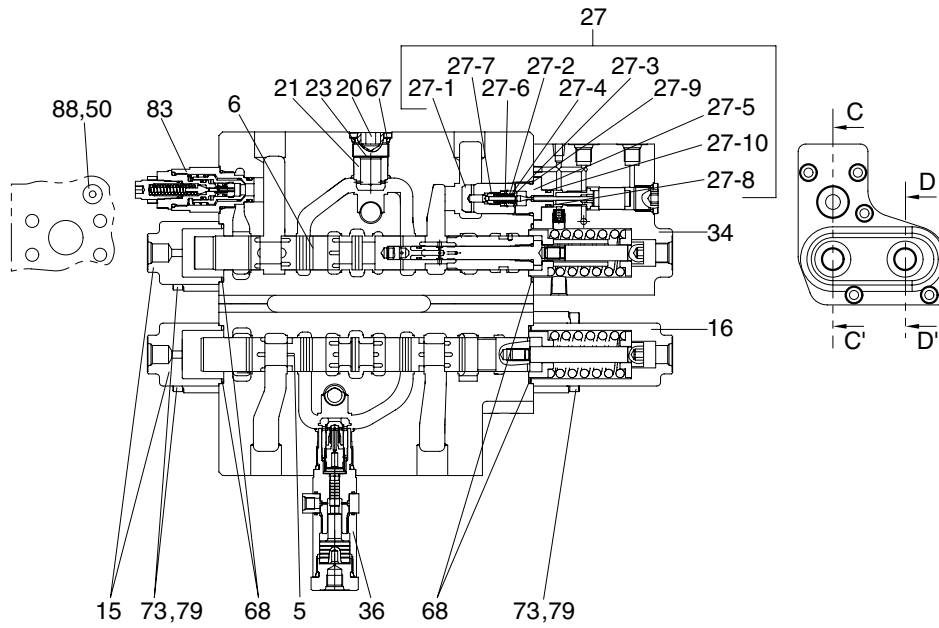

C-C' (SWING & BOOM1)

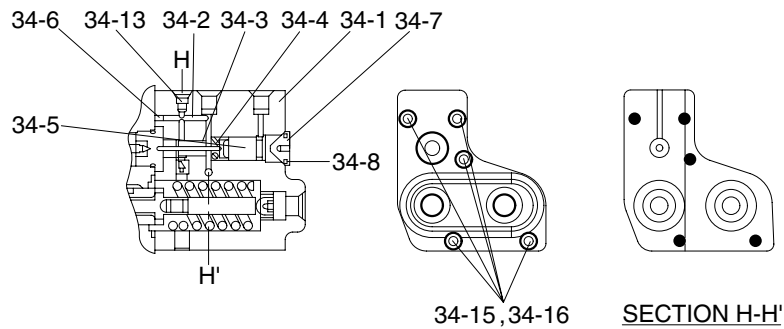

34 DETAIL (HOLDING ASSY)

2909MH2MC04

5	Spool-swing	27-6	C-ring	34-8	Plug
6	Spool-boom	27-7	Restrictor-lock valve	34-13	Plug
15	Cover-pilot A	27-8	O-ring	34-15	Socket bolt
16	Cover-pilot B1	27-9	O-ring	34-16	Spring washer
20	Plug	27-10	Back up ring	36	Logic valve
21	Poppet 1-check valve	34	Holding kit-A1	50	O-ring
23	Spring 1-check valve	34-1	Block-H/D P1	67	O-ring
27	Holding kit-B	34-2	Piston 1-holding	68	O-ring
27-1	Poppet	34-3	Guide piston-holding	73	Hex socket head bolt
27-2	Spring	34-4	Spring 1-lock valve	79	Washer
27-3	Poppet guide	34-5	Piston 2-holding	83	Overload relief valve
27-4	Pilot poppet	34-6	Plug	88	Plug
27-5	Poppet seat	34-7	Plug		

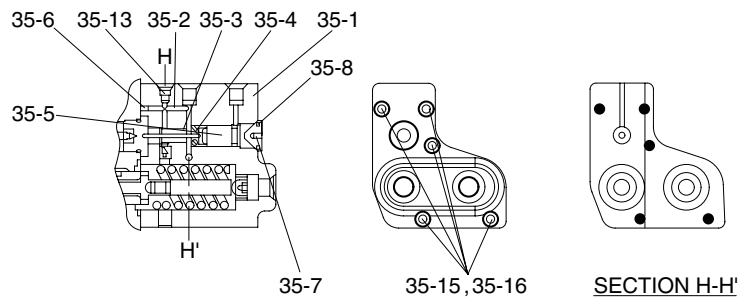
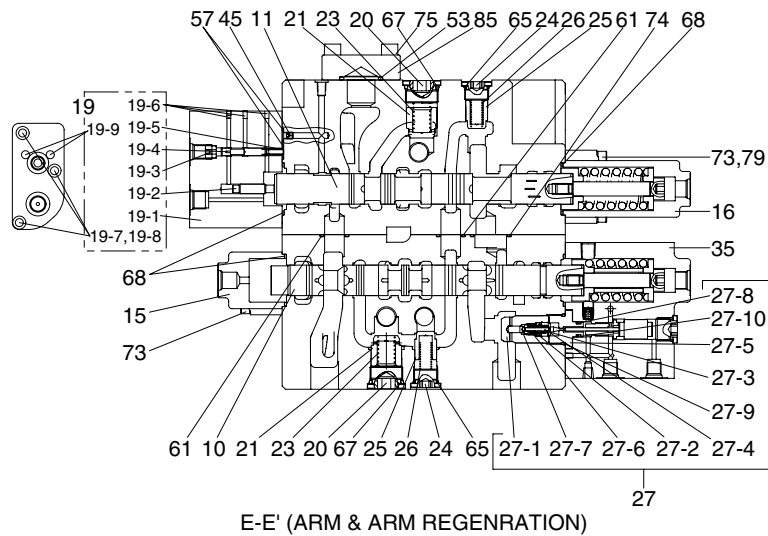

35 DETAIL (HOLDING ASSY)

2909MH2MC05

10	Spool-arm	26	Spring 2-check valve	35-7	Plug
11	Spool-arm regeneration	27	Poppet-lock valve	35-8	Plug
15	Cover-pilot A	27-1	Poppet	35-13	Plug
16	Cover-pilot B1	27-2	Spring	35-15	Socket bolt
19	Arm-regeneration	27-3	Poppet guide	35-16	Spring washer
19-1	Block-regeneration	27-4	Pilot poppet	45	Orifice-plug
19-2	Piston-cut off	27-5	Poppet seat	53	Flange
19-3	Stopper-regeneration	27-6	C-ring	57	O-ring
19-4	Spool-regeneration	27-7	Restrictor-lock valve	61	O-ring
19-5	Spring-regeneration	27-8	O-ring	65	O-ring
19-6	Plug	27-9	O-ring	67	O-ring
19-7	Socket bolt	27-10	Back up ring	68	O-ring
19-8	Spring wahser	35	Holding kit-A2	73	Hex socket head bolt
19-9	Pin-regeneration	35-1	Block-H/D P2	74	O-ring
20	Plug	35-2	Piston 1-holding	75	Socket bolt
21	Poppet 1-check valve	35-3	Guide piston-holding	79	Washer
23	Spring 1-check valve	35-4	Spring 1-lock valve	85	O-ring
24	Plug	35-5	Piston 2-holding		
25	Poppet 2-check valve	35-6	Plug		

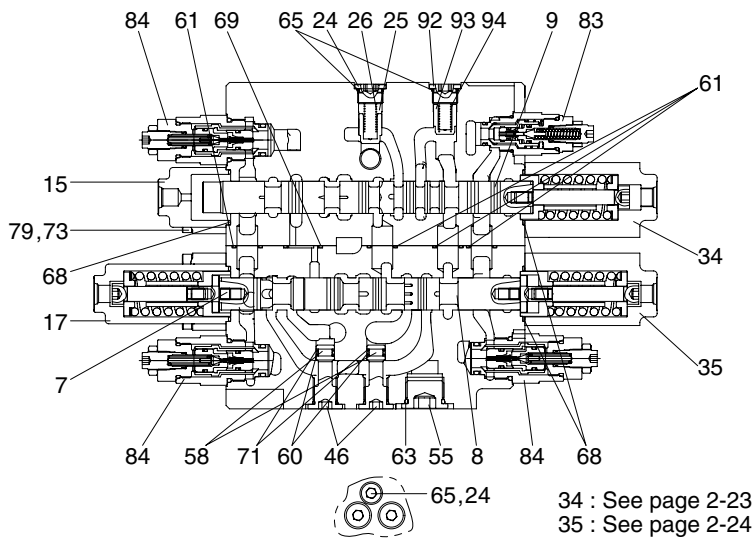

D-D' (SWING PRIORITY-BOOM2 & ARM2)

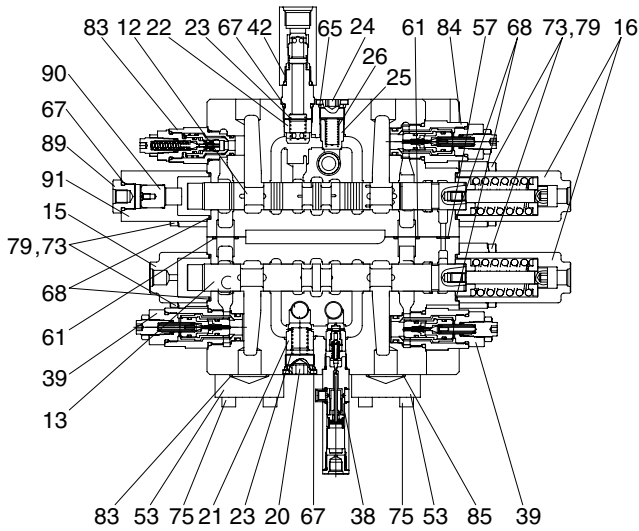

F-F' (SERVICE & GRAPPLE)

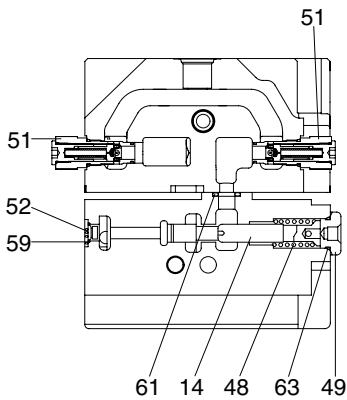

G-G' (CENTER BYPASS CUT-OFF
& NEGATIVE CONTROL)

- 7 Spool-swing priority
- 8 Spool-boom 2
- 9 Spool-arm 2
- 12 Spool-grapple
- 13 Spool-option
- 14 BC spool
- 15 Cover-pilot A
- 16 Cover-pilot B1
- 17 Cover-pilot B2
- 20 Plug
- 21 Poppet 1-check valve
- 22 Poppet L/C-bucket
- 23 Spring 1-check valve
- 24 Plug
- 25 Poppet 2-check valve
- 26 Spring 2-check valve
- 38 Load check valve assy
- 39 Overload relief valve
- 42 Check valve
- 46 Plug
- 48 Spring-BC spool
- 49 Plug-BC spool
- 51 Negative control valve
- 52 Plug
- 53 Flange
- 55 Plug
- 57 O-ring
- 58 O-ring
- 59 O-ring
- 60 O-ring
- 61 O-ring
- 63 O-ring
- 65 O-ring
- 67 O-ring
- 68 O-ring
- 69 O-ring
- 71 Back-up ring
- 73 Hex socket head bolt
- 75 Socket bolt
- 79 Washer
- 83 Overload relief valve
- 84 Overload relief valve
- 85 O-ring
- 89 Plug
- 90 Piston
- 91 Pilot cover C1
- 92 Plug
- 93 Poppet
- 94 Spring

2909MH2MC06

3. DISASSEMBLY AND ASSEMBLY

1) GENERAL PRECAUTIONS

- (1) As hydraulic equipments, not only this valve are constructed precisely with very small clearances, disassembling and assembling must be carefully done in a clean place with preventing dusts and contaminants from entering.
- (2) Prepare the section drawing and study the structure of MCV and then start disassembly work.
- (3) When removing the control valve from the machine, install caps on every ports, and wash the outside of the assembly with confirming the existence of caps before disassembling.
Prepare a suitable table and some clean papers or rubber mat on the table for disassembling.
- (4) If the components are left disassembled, they may get rust. Make sure to measure the greasing and sealing.
- (5) For carrying the control valve, never hold with pilot cover or relief valve and overload relief valve and carefully treat the valves.
- (6) Do not tap the valve even if the spool movement is not smooth.
- (7) Several tests for such as relief characteristics, leakage, overload relief valve setting and flow resistance are required after re-assembling, and the hydraulic test equipments for those tests are needed.
Therefore, do not disassemble what cannot perform test adjustment, even if it can disassemble.

※ Be sure to observe the mark (※) description in the disassembly and assembly procedures.

2) TOOLS

Before disassembling the control valve, prepare the following tools beforehand.

Name of tool	Quantity	Size (mm)
Vice mounted on bench (soft jaws)	1 unit	
Hexagon wrench	Each 1 piece	5, 6, 10, 12 and 14
Socket wrench	Each 1 piece	27 and 32
Spanner	Each 1 piece	26 and 32 (main relief valve)

3) DISASSEMBLY

(1) Removing spool

① The case of the section without holding valve

Instruction for removing the travel spool (for instance) is follows :

Remove two hex socket bolts by 5 mm allen key wrench, then remove pilot cover.

- ※ Pay attention not to lose the O-ring under the pilot cover.

As the return spring portion of travel spool comes out, pull the spring straight slowly, by which spool assembly is removed.

- ※ The spools have to remove from the spring side.

Other spools (no lock valve type) can be removed in the same manner but the swing priority spool is reversed.

- ※ When spool replace, do not disassemble of a spool by any cases. Please replace by spool assembly.

- ※ Please attach using a tag etc. in the case of two or more kinds of spool replace, and understand a position.

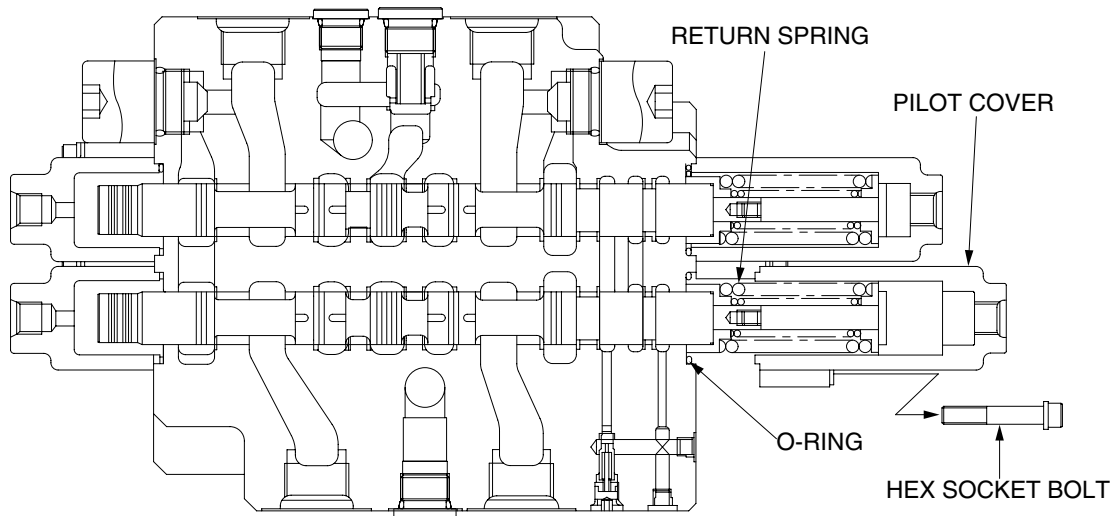

29098MC01

② **The case of the section with holding valve**

Instruction for removing the boom spool (for instance) is follows :

Remove five hex socket bolts with washer by 5 mm allen key wrench. Then remove pilot cover with internal parts below figure.

- ※ Be careful not to separate O-ring and poppet under pilot cover.
- ※ Pay attention not to damage the exposed piston A under pilot cover.

As the return spring portion of boom 1 spool comes out, pull the spring straight slowly, by which spool assembly is removed.

- ※ The spools have to remove form the spring side.
- ※ When spool replace, do not disassemble of a spool by any cases, please replace by spool assembly.

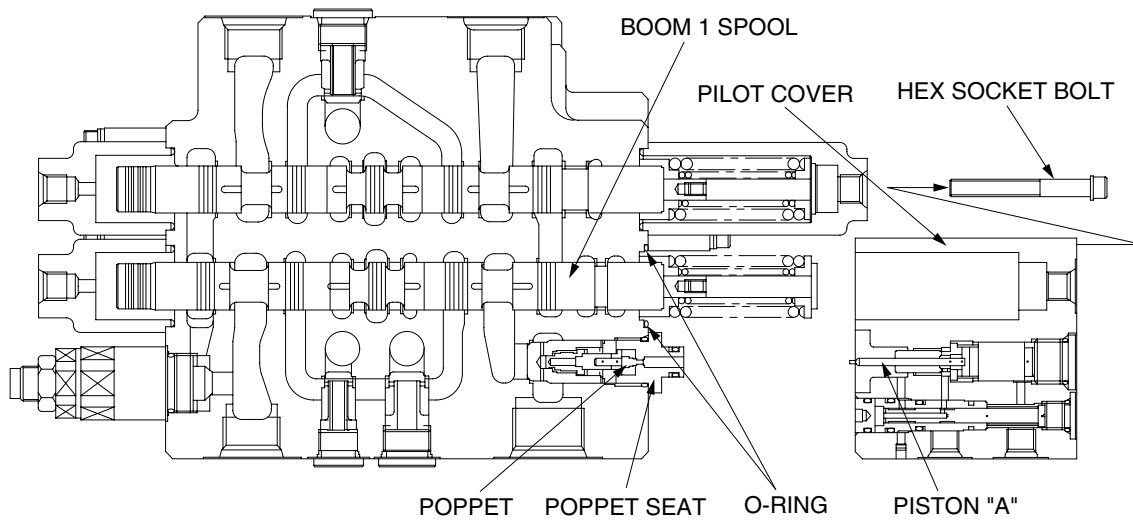

29098MC02

(2) Removing holding valve

Remove the pilot cover with the holding valve as described on previous page.

- ※ Do not disassembled internal parts of the pilot cover.

Loosen the poppet seat by 26 mm spanner and remove the poppet, the spring seat, the spring and the check in order.

- ※ Pay attention not to lose the poppet.
- ※ Do not disassembled internal parts of the check because the plug, functioning orifice, can damage easily.

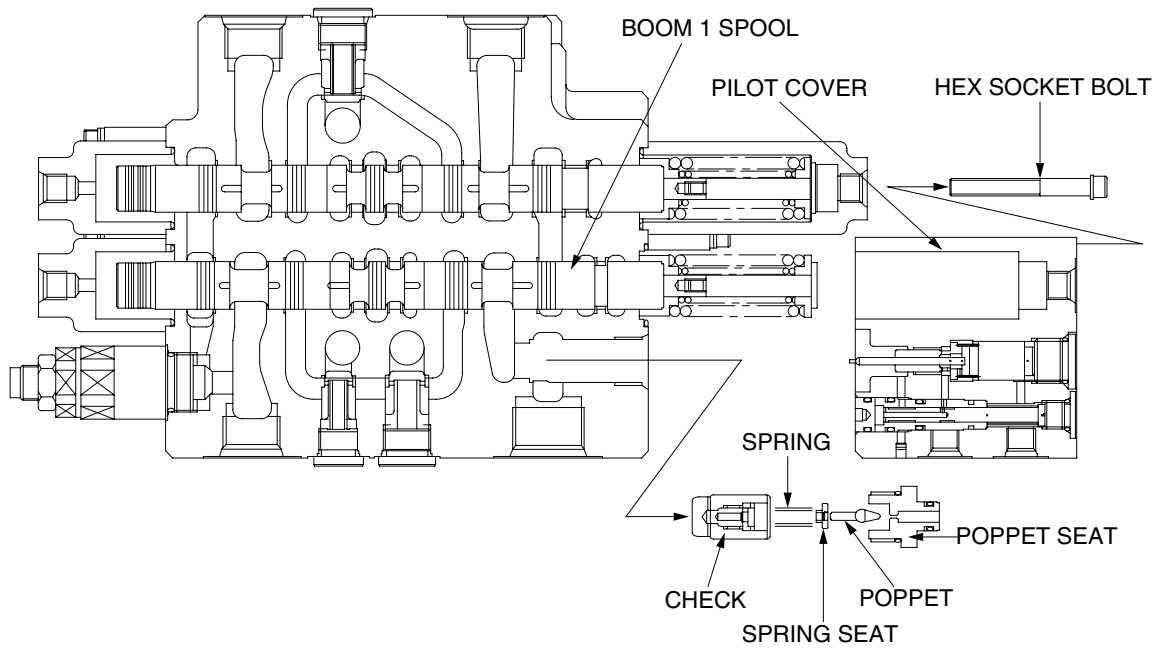

29098MC03

(3) Removing load check valve and negative relief valve

① The load check valve

- Fix the body to suitable work bench. Loosen the plug by 10 mm allen key wrench.
- Remove the spring and the load check valve with pincers or magnet.

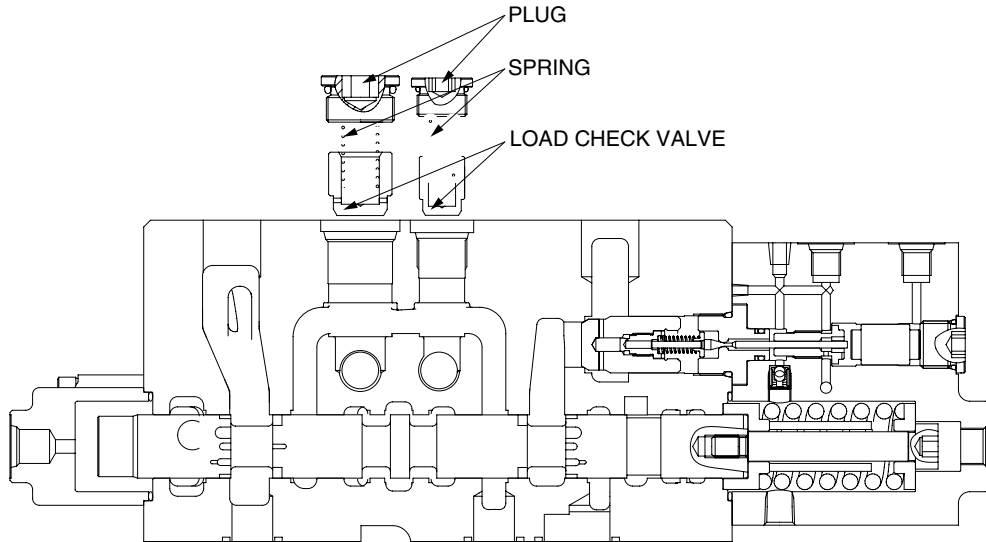

29098MC04

② The negative relief valve

- Loosen the socket by 12 mm allen key wrench.
- Remove the spring, the spring holder, the piston and the negative control poppet.

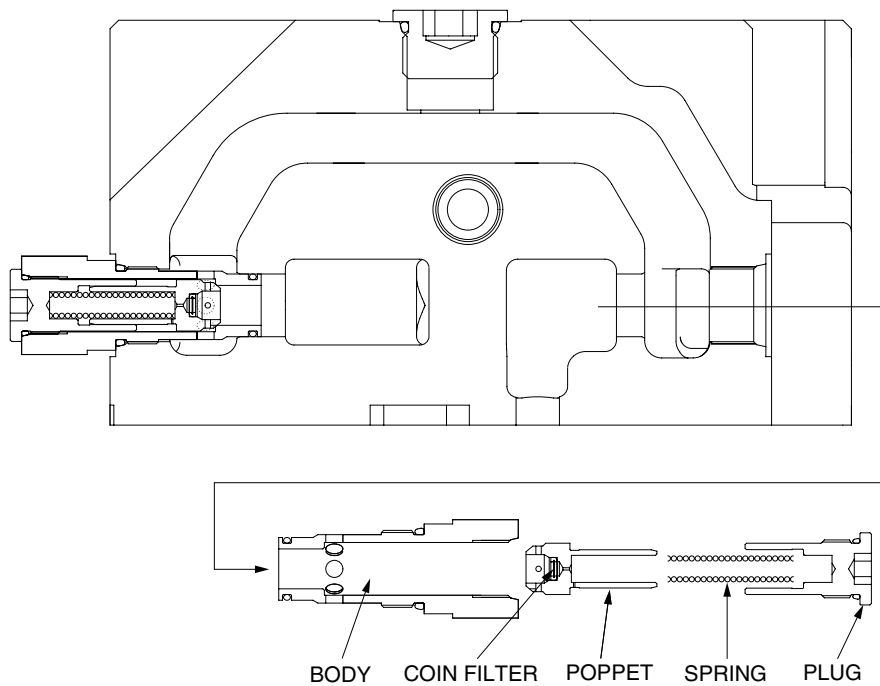

29098MC05

※ Do not disassemble the coin filter inside the negative control poppet because of forced fit.

(4) Removing main relief valve and overload relief valve

Fix the valve body to suitable work bench. Remove the main relief valve by 32 mm spanner and remove the overload relief valve 32 mm spanner (standard) or 36 mm spanner (optional).

- ※ When disassembled, tag the relief valve for identification so that they can be reassembled correctly.
- ※ Pay attention not to damage seat face of disassembled main relief and overload relief valve.
- ※ Main relief and overload relief valve are very critical parts for performance and safety of the machine. Also, the pressure set is very difficult. Therefore, any abnormal parts are found, replace it with completely new relief valve assembly.

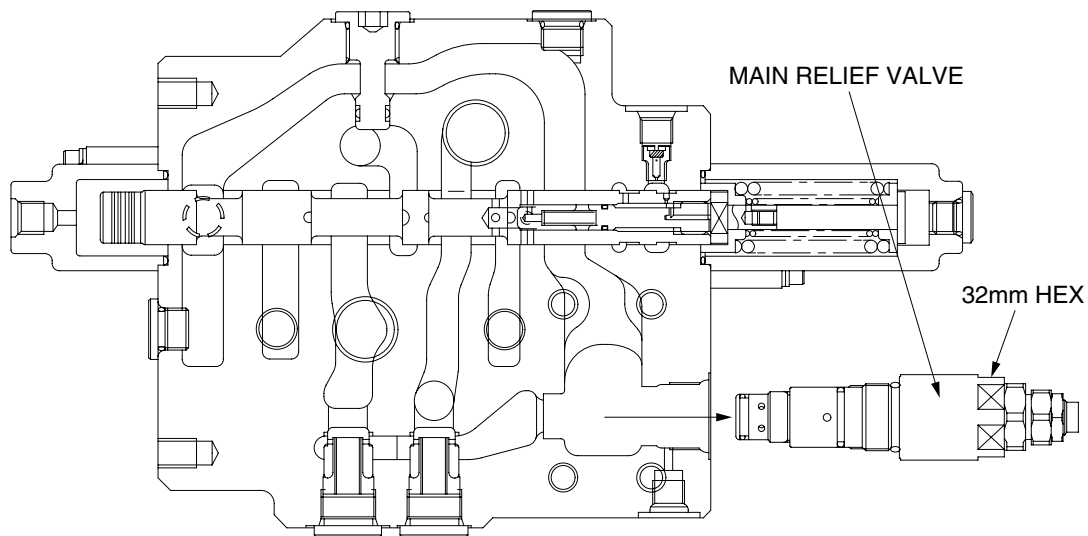

29098MC06

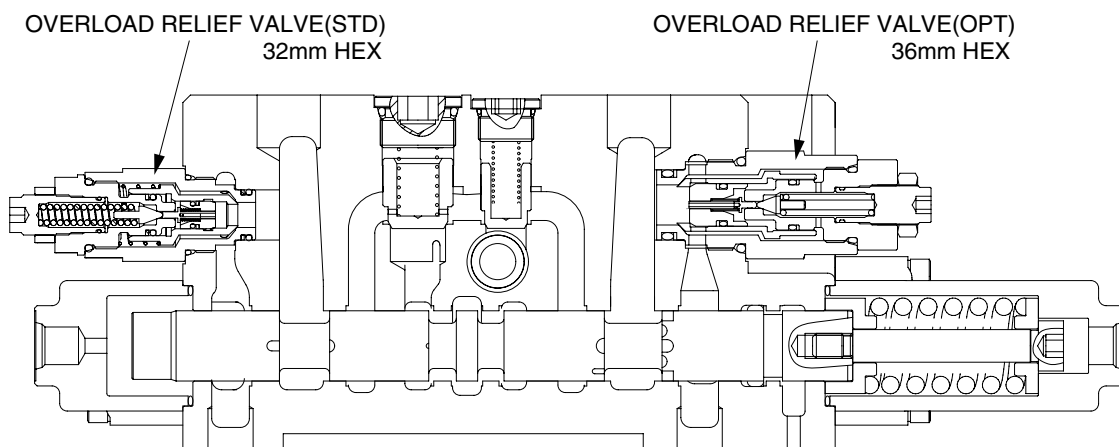

29098MC07

(5) Removing the swing logic valve and bucket logic valve

- Fix the valve body to suitable work bench.
 - Loosen the body 2 by 32 mm spanner (swing logic valve) or 24 mm spanner (bucket logic valve) and remove it.
 - Remove the banjo plate.
 - Loosen the body 1 as the same spanner of body 2 and remove it.
 - Remove the check poppet and spring.
- ※ Pay attention not to damage seat face of removed check poppet.
- ※ Do not disassemble the check poppet and replace it with a assembly in case any abnormal parts are found.
- ※ Pay attention not to lose and separation while disassembling and assembling.

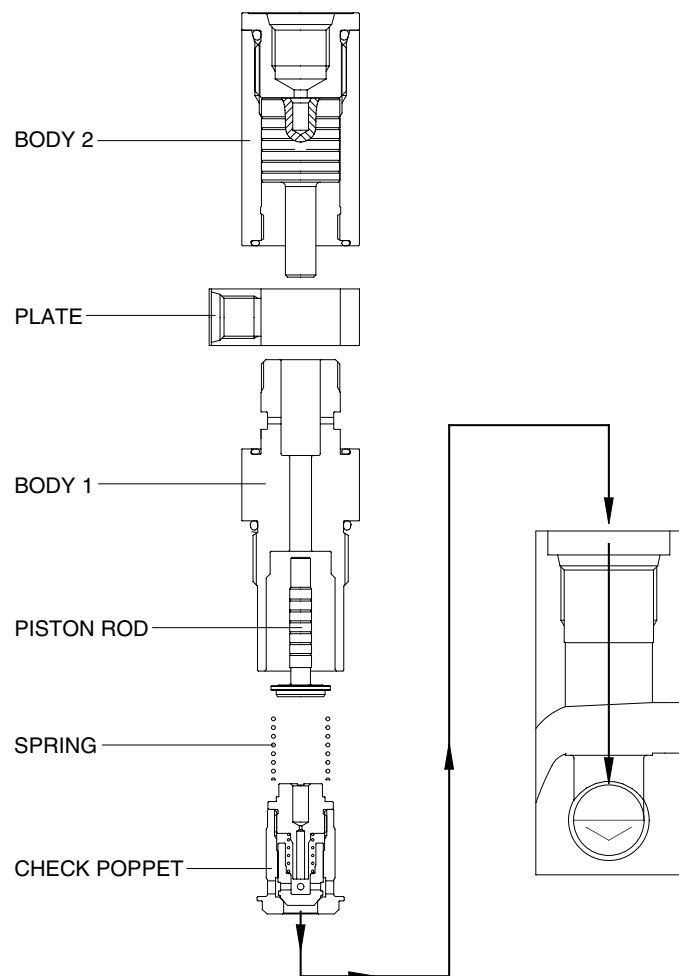

29098MC08

(6) Removing the option ON/OFF valve

- Fix the valve body to suitable work bench.
- Loosen the body 2 by 24 mm spanner and remove it.
- Remove the banjo plate.
- Loosen the body 1 as the same spanner of body 2 and remove it.
- Remove the pilot poppet, spring and seat.
- Remove the check poppet.

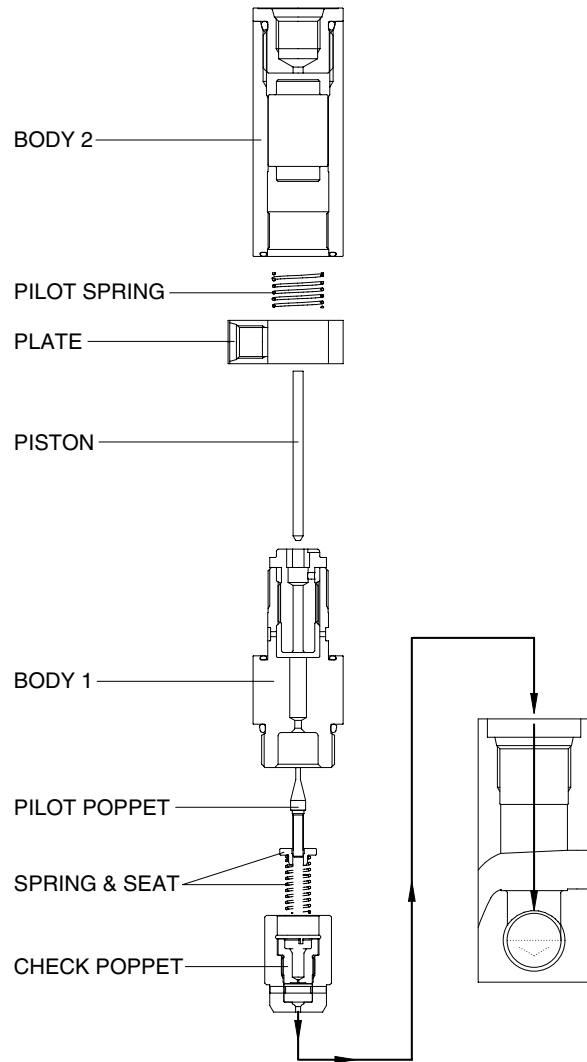

29098MC09

4) ASSEMBLY

(1) Precaution

- ① When you assemble, please wash all parts by pure cleaning liquid.
- ② For re-assembling, basically use only brand new seals for all portions.
- ③ Apply grease or hydraulic oil to the seals and seal fitting section to make the sliding smooth, unless otherwise specified.
- ④ Pay attention not to roll the O-ring when fitting and it may cause oil leakage.
- ⑤ Do not tap the valve even if the spool movement is not smooth.
- ⑥ Prepare the section drawing and study the structure of MCV and then start disassembly work.
- ⑦ Tighten bolt and parts with thread for all section by torque wrench to the respective tightening torque.

(2) Assembly

Explanation only is shown for the assembly, refer to the figures shown in the previous disassembly section.

① Main relief and overload relief valve

Fix the valve body to suitable work bench.

Install main relief valve and overload relief valve into the body and tighten to the specified torque by 32 mm torque wrench.

· Tightening torque : 8~9 kgf·m (57.8~65.1 lbf·ft)

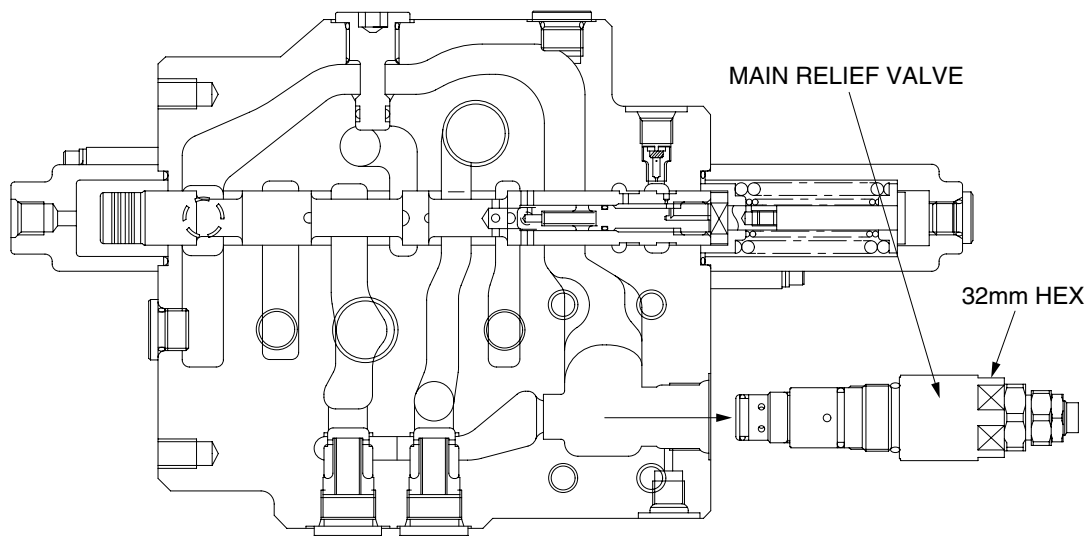

29098MC06

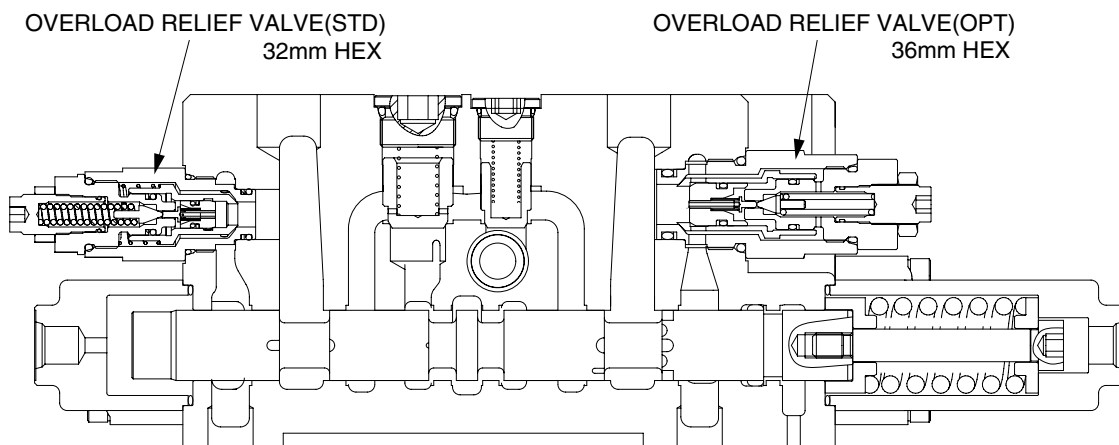

29098MC07

② Load check valve

Assemble the load check valve and spring.

Put O-rings on to plug and tighten plug to the specified torque by 10 mm torque wrench.

· Tightening torque : 6~7 kgf·m (43.4~50.6 lbf·ft)

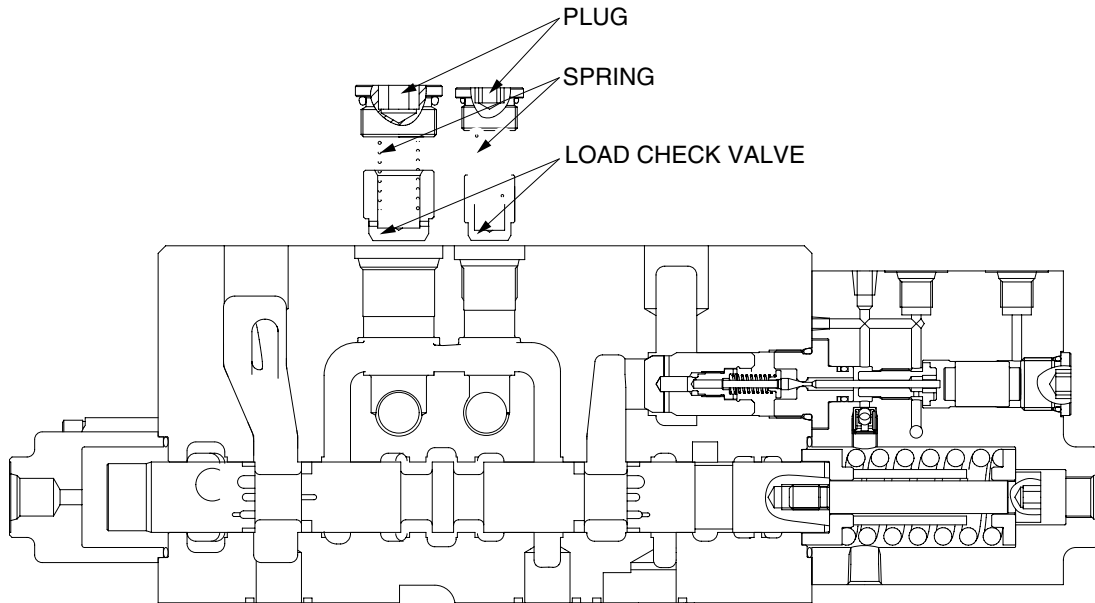

29098MC04

③ Negative control relief valve

Assemble the nega-con poppet, piston, spring holder and spring into body in order and tighten the socket to the specified torque by 12 mm torque wrench.

· Tightening torque : 8~9 kgf·m (57.8~65.1 lbf·ft)

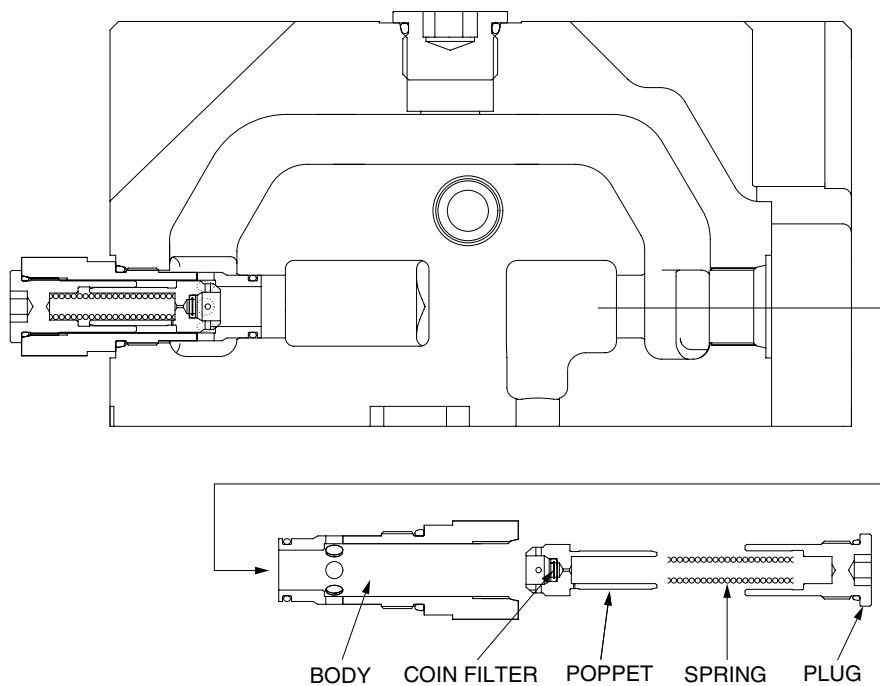

29098MC05

④ Holding valves

Assemble the check, spring seat and poppet into the hole of valve body in order.

Tighten the poppet seat to the specified torque by 25 mm torque wrench.

· Tightening torque : 6~7 kgf·m (43.4~50.6 lbf·ft)

Fit the "piston A" under pilot cover with internal parts into hole on the poppet seat.

Tighten hexagon socket head bolt to specified torque by 5 mm torque wrench.

· Tightening torque : 1~1.1 kgf·m (7.2~7.9 lbf·ft)

※ Pay attention poppet not to separation.

※ Confirm that O-rings have been well fitted on the groove of body. (Apply grease on O-ring)

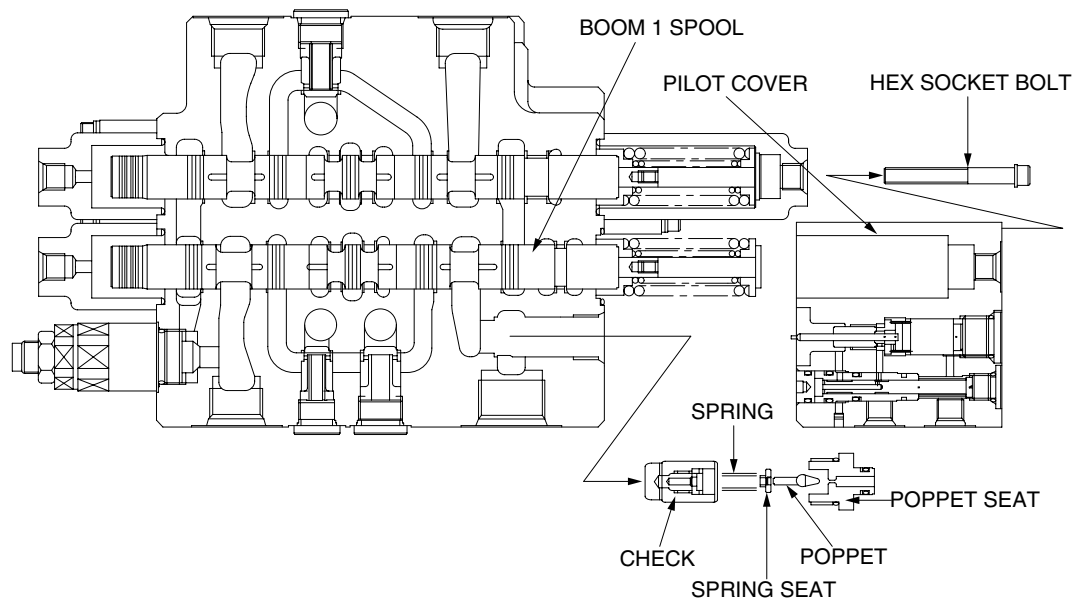

29098MC03

⑤ Main spool

Put the spool position upward and fix it to the vise. Carefully insert the previously assembled spool assemblies into their respective bores within of body.

Fit spool assemblies into body carefully and slowly. Do not under any circumstances push them forcibly in.

Fit the pilot cover to the groove of the valve body.

Confirm that O-rings have been fitted on the groove of body. (Apply grease on O-ring)

Tighten the two socket bolt to the specified torque by 5 mm torque wrench.

· Tightening torque : 1~1.1 kgf·m (7.2~7.9 lbf·ft)

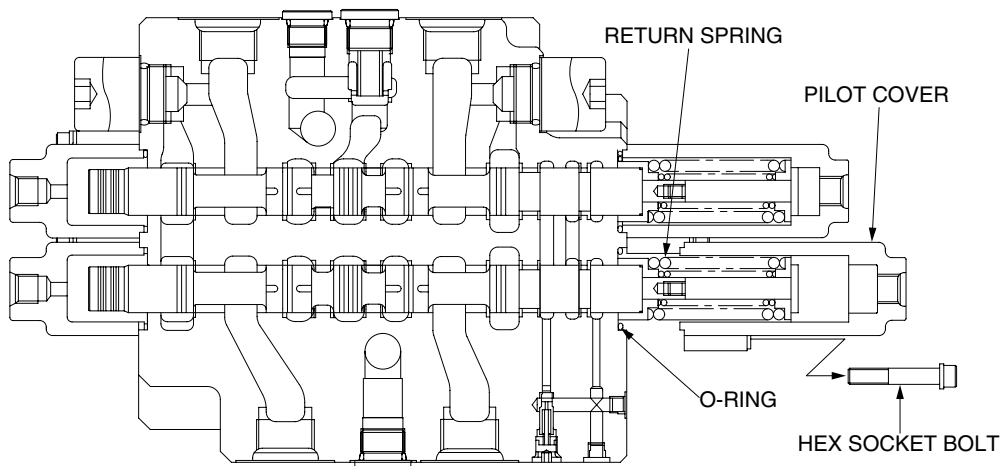

29098MC01

⑥ The swing logic valve and bucket logic valve

- Assemble the piston rod, spring and check poppet into the body 1 in order.
 - Install the body 1 assembly into valve body and tighten to the specified torque.
 - Tightening torque : 2.9 kgf·m (21.0 lbf·ft)
 - Assemble the banjo plate.
- ※ Confirm O-ring has been seated on the groove of banjo plate.
- Tighten the body 2 to the specified torque.
 - Tightening torque : 1.5 kgf·m (10.8 lbf·ft)

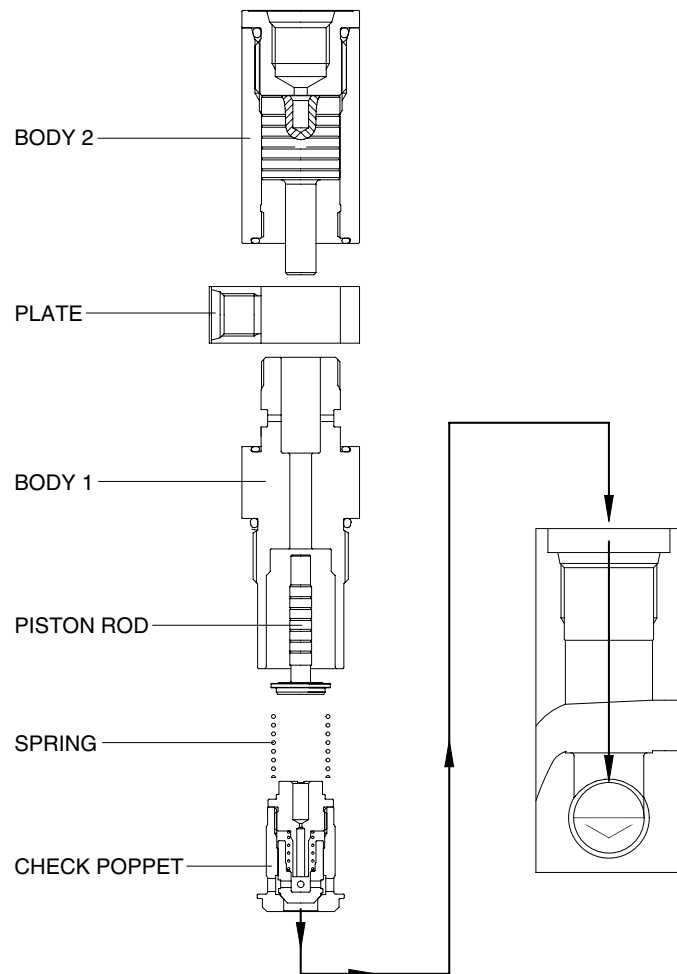

29098MC08

⑦ Option ON/OFF valve

- Assemble the check poppet into the valve body.
- ※ Push the check poppet about half of hole.
- Assemble the pilot poppet, spring and seat into check poppet.
- ※ As it can not be fixed, hang it diagonally.
- Insert the end of pilot poppet into the machined center hole of body 1 and push it complete
- slowly. Then tighten to the specified torque.
 - Tightening torque : 2.9 kgf·m (21.0 lbf·ft)
- ※ Tighten socket piston.
- When push the piston to the end, confirm the repulsive spring force.
- Assemble the banjo plate.
- Put the pilot spring into body 2 and assemble it into body 1 and then tighten to the specified torque.
 - Tightening torque : 1.5 kgf·m (10.8 lbf·ft)

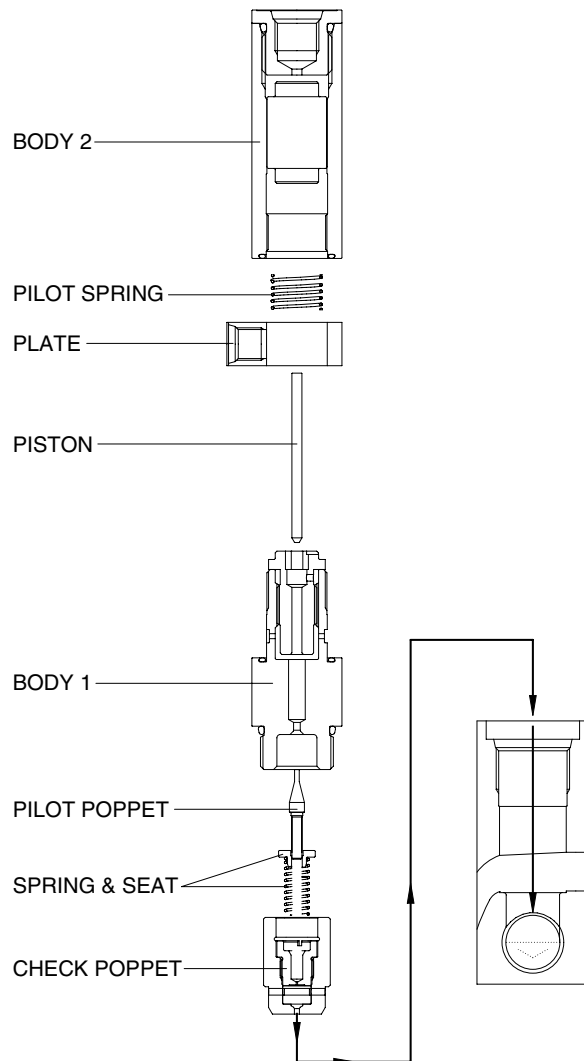

29098MC09