

GROUP 4 HYDRAULIC SYSTEM

HYDRAULIC COMPONENTS MOUNTING 1

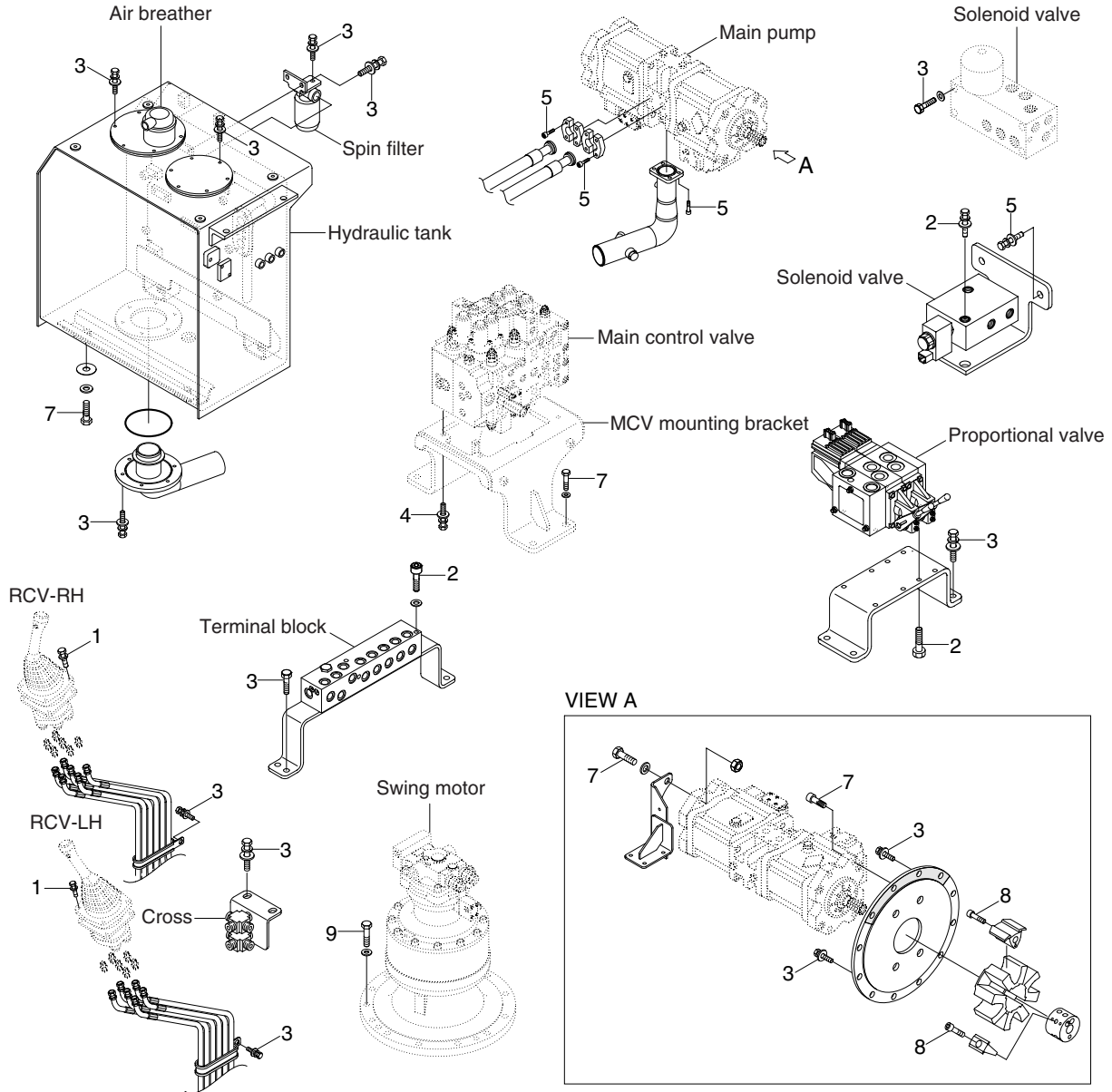

2909MH9CM05

• Tightening torque

Item	Size	kgf · m	lbf · ft
1	M 6×1.0	1.05±0.2	7.6±1.45
2	M 8×1.25	2.5±0.5	18.1±3.6
3	M10×1.5	6.9±1.4	49.9±10.1
4	M12×1.75	12.3±1.3	88.9±9.4
5	M12×1.75	12.8±3.0	92.5±21.6

Item	Size	kgf · m	lbf · ft
6	M20×2.5	42±4.5	304±32.5
7	M20×2.5	46±5.1	333±36.9
8	M20×2.5	46.5±2.5	336±18.1
9	M20×2.5	58.4±6.4	422±46.2
-	-	-	-

HYDRAULIC COMPONENTS MOUNTING 2

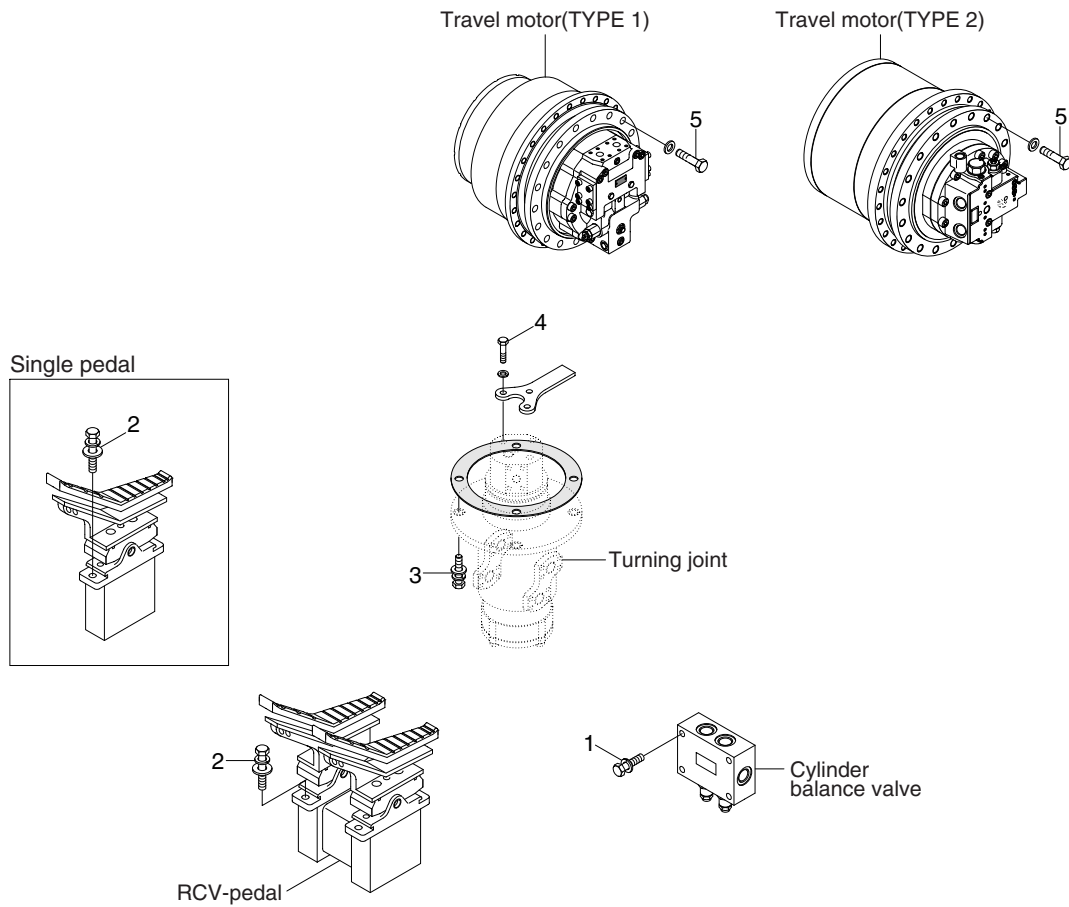

2909MH9CM06

· Tightening torque

Item	Size	kgf · m	lbf · ft
1	M 8×1.25	4.05±0.8	29.3±5.8
2	M10×1.5	6.9±1.4	49.9±10.1
3	M12×1.75	12.8±3.0	92.6±21.7

Item	Size	kgf · m	lbf · ft
4	M14×2.0	19.6±2.9	142±20.9
5	M24×3.0	84±8.0	723±72.3
-	-	-	-

HYDRAULIC COMPONENTS MOUNTING 3

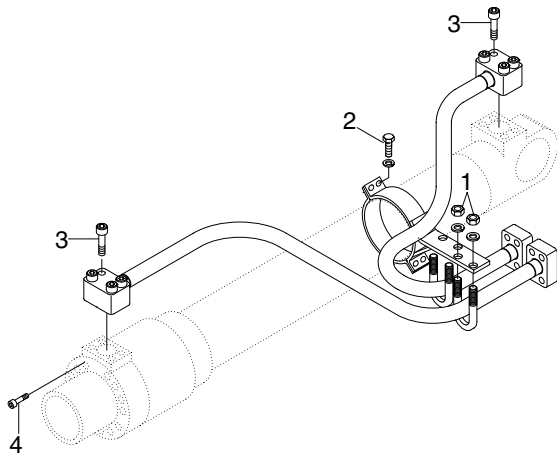

BOOM CYLINDER

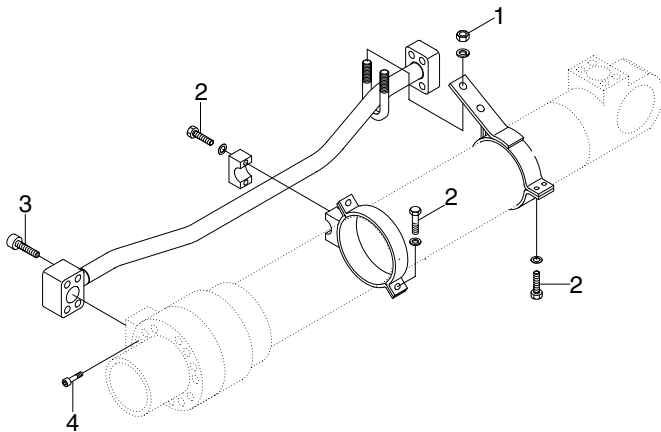

ARM CYLINDER

Solenoid valve

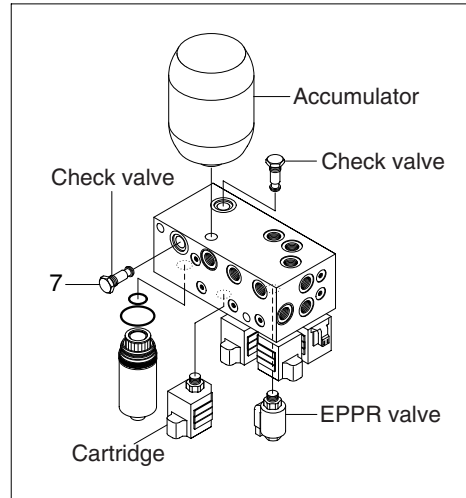

2909MH9CM07

· Tightening torque

Item	Size	kgf · m	lbf · ft
1	M10×1.5	3.2±0.3	23.1±2.2
2	M12×1.75	5.5±0.6	39.8±4.3
3	M12×1.75	9.4±1.0	68.0±7.2

Item	Size	kgf · m	lbf · ft
4	M18×2.5	32±3.0	232±21.7
5	-	2.5±0.5	18±3.6
-	-	-	-