

GROUP 2 ENGINE SYSTEM

ENGINE AND ACCESSORIES MOUNTING

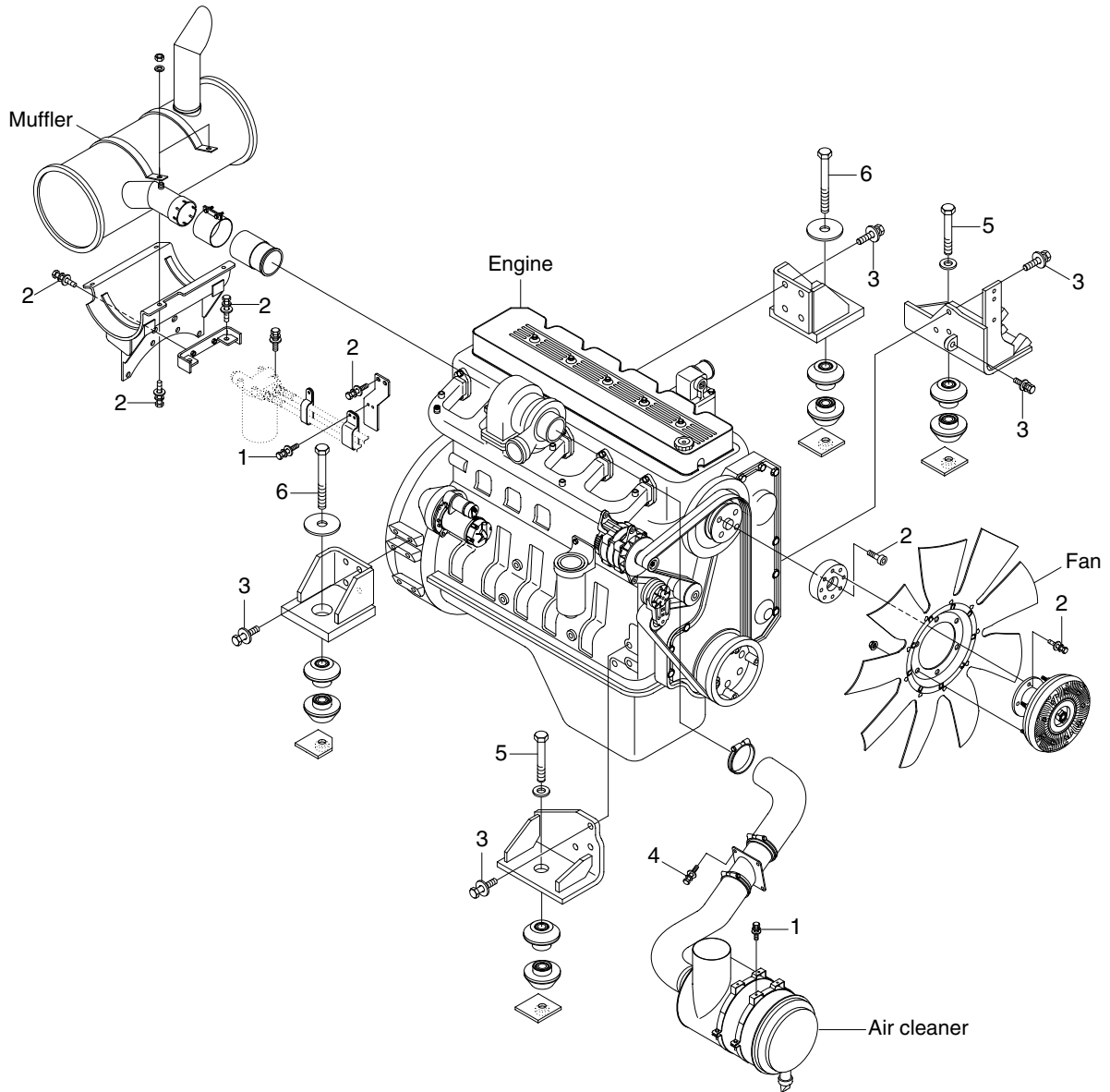

2909MH9CM01

· Tightening torque

Item	Size	kgf · m	lbf · ft
1	M 8×1.25	2.5±0.5	18.1±3.6
2	M10×1.5	6.9±1.4	49.9±10.1
3	M12×1.75	9.7±1.9	70.2±13.7

Item	Size	kgf · m	lbf · ft
4	M12×1.75	12.8±3.0	92.6±21.7
5	M20×2.5	55±3.5	398±25.3
6	M24×3.0	90±7.0	651±51

COOLING SYSTEM AND FUEL TANK MOUNTING

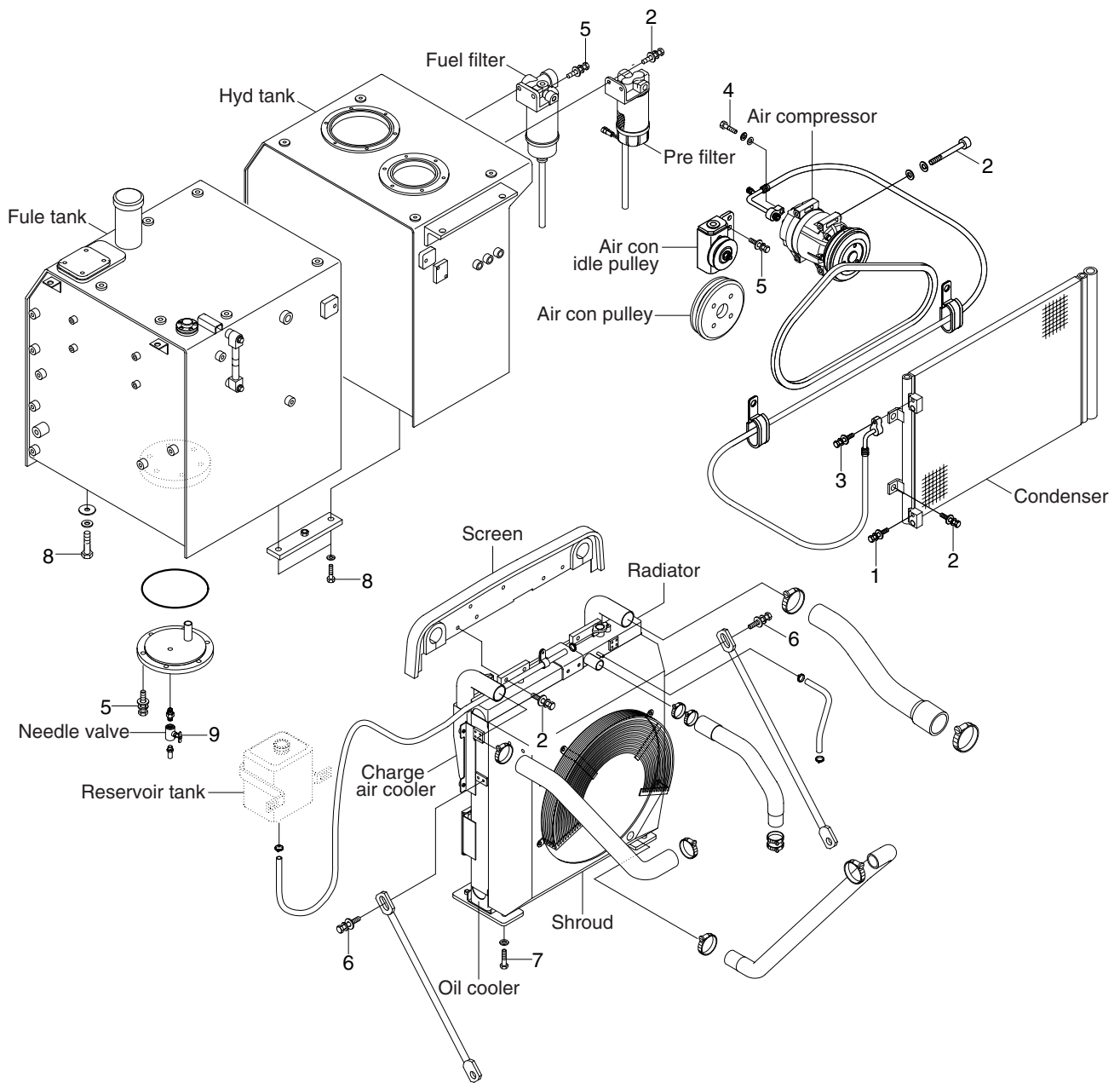

2909MH9CM02

· Tightening torque

Item	Size	kgf · m	lbf · ft
1	M 6×1.0	0.5±0.2	3.6±1.45
2	M 8×1.25	2.5±0.5	18.1±3.6
3	M 8×1.25	1.3±0.2	9.4±1.45
4	M10×1.25	5.0±0.2	36.1±1.45
5	M10×1.5	6.9±1.4	49.9±10.1

Item	Size	kgf · m	lbf · ft
6	M12×1.75	12.8±3.0	92.6±21.7
7	M16×2.0	29.7±4.5	215±32.5
8	M20×2.5	46±5.1	333±36.9
9	-	2.3±0.6	16.6±4.3