

GROUP 5 SWING DEVICE

1. REMOVAL AND INSTALL OF MOTOR

1) REMOVAL

(1) Lower the work equipment to the ground and stop the engine.

(2) Loosen the breather slowly to release the pressure inside the hydraulic tank.

▲ Escaping fluid under pressure can penetrate the skin causing serious injury.

※ When pipes and hoses are disconnected, the oil inside the piping will flow out, so catch it in oil pan.

(3) Disconnect pipe assy (2, 3).

(4) Disconnect pilot line hoses (4, 5, 6, 7, 8, 9).

(5) Sling the swing motor assembly (1) and remove the swing motor mounting bolts (10).

- Motor device weight : 70 kg (150 lb)
- Tightening torque : 58.4 kgf · m
(422.4 lbf · ft)

(6) Remove the swing motor assembly.

※ When removing the swing motor assembly, check that all the piping have been disconnected.

2) INSTALL

(1) Carry out installation in the reverse order to removal.

(2) Bleed the air from the swing motor.

- ① Remove the air vent plug.
- ② Pour in hydraulic oil until it over flows from the port.
- ③ Tighten plug lightly.
- ④ Start the engine, run at low idling, and check oil come out from plug.
- ⑤ Tighten plug fully.

(3) Confirmed the hydraulic oil level and check the hydraulic oil leak or not.

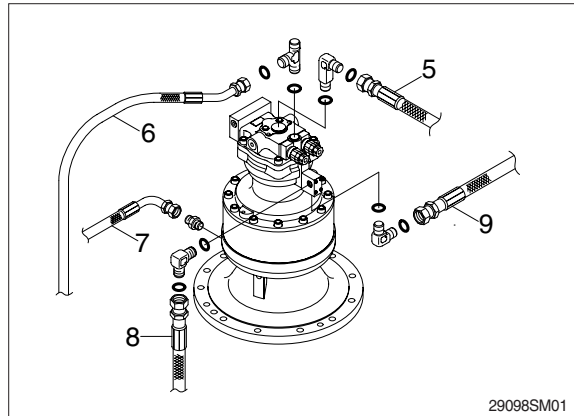
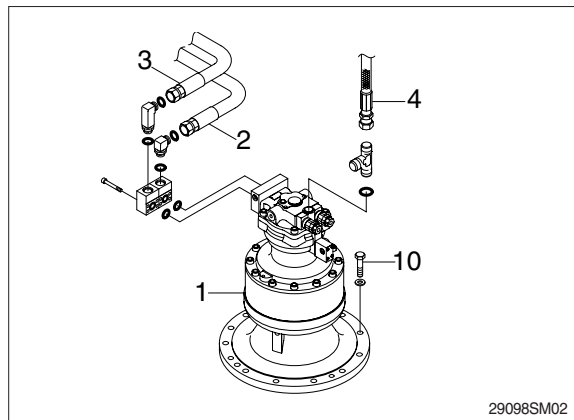

2. SWING MOTOR

1) STRUCTURE

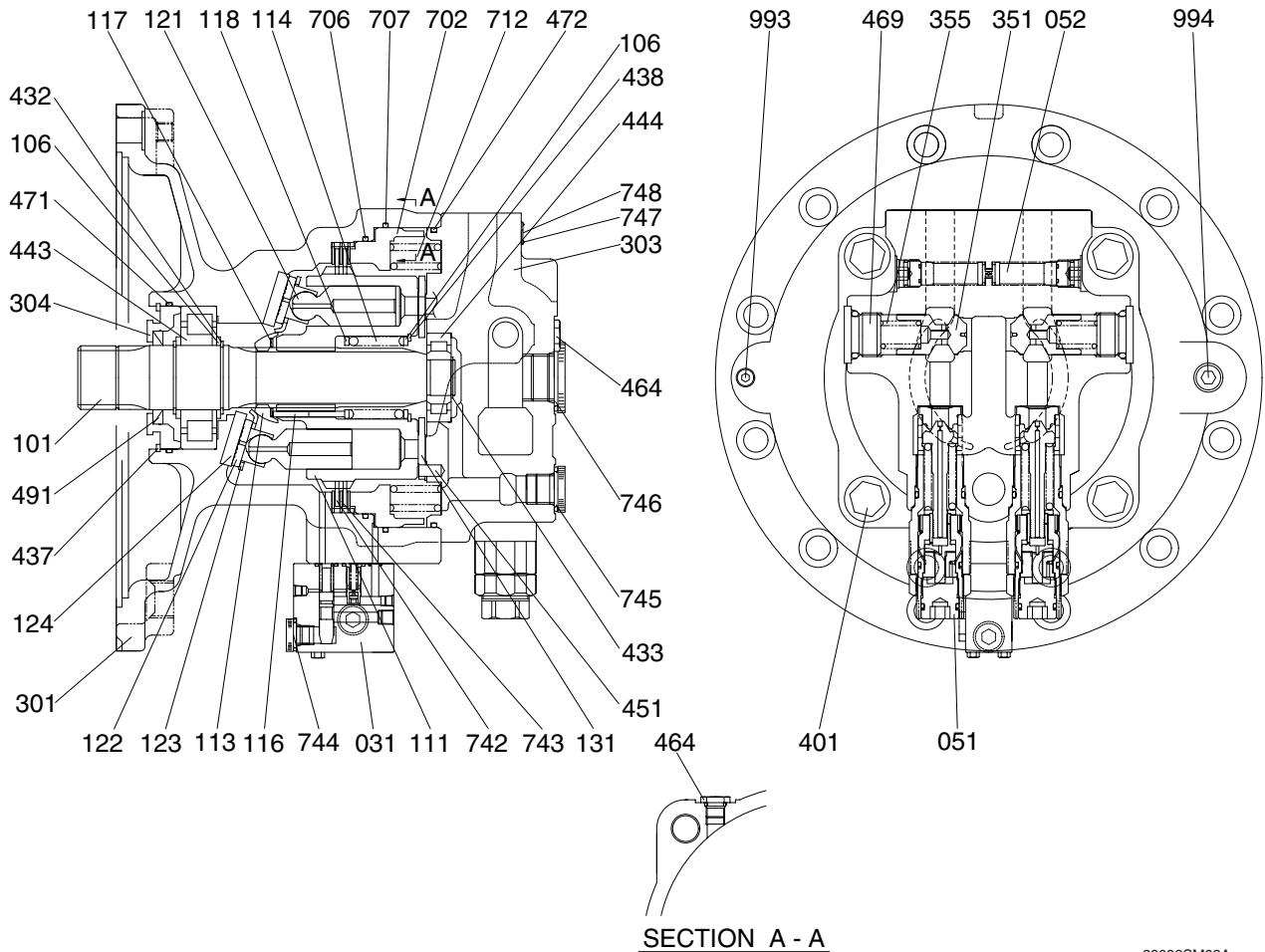

031	Brake valve	301	Casing	472	O-ring
051	Relief valve	303	Valve casing	491	Oil seal
052	Swing reactionless valve assy	304	Front cover	702	Brake piston
101	Drive shaft	351	Plunger	706	O-ring
106	Spacer	355	Spring	707	O-ring
111	Cylinder block	401	Socket bolt	712	Brake spring
113	Spherical bush	432	Snap ring	742	Friction plate
114	Spring	433	Snap ring	743	Separate plate
116	Push rod	437	Snap ring	744	Dust plug
117	Spacer-F	438	Snap ring	745	Dust plug
118	Spacer-R	443	Roller bearing	746	Dust plug
121	Piston	444	Roller bearing	747	Name plate
122	Shoe	451	Spring pin	748	Rivet screw
123	Retainer	464	Plug	993	Level gauge
124	Shoe plate	469	Plug	994	Plug
131	Valve plate	471	O-ring		

2) DISASSEMBLY

- (1) Lift the motor out. Clean the motor in kerosene and dry with compressed air.
 - ※ To avoid dust inside the motor, mask all the ports of the motor with tapes.

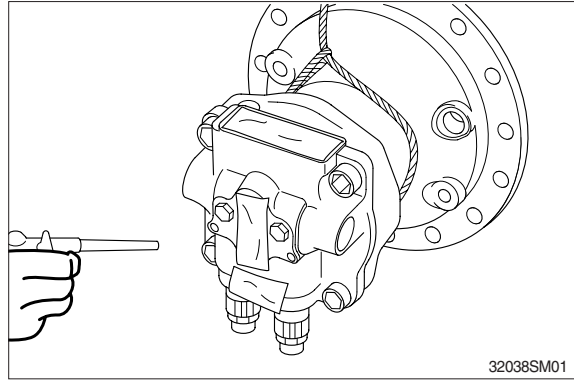

- (2) Loosen the drain plug to discharge oil in the casing (301).

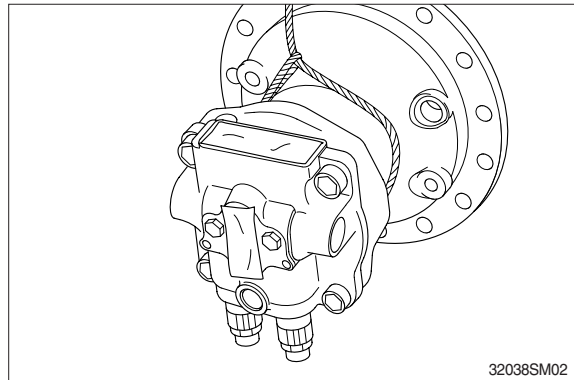

- (3) Fix the drive shaft (101) on the workbench with the end of output shaft down. Put matching marks on casing (301) and valve casing (303) for easy reassembly.

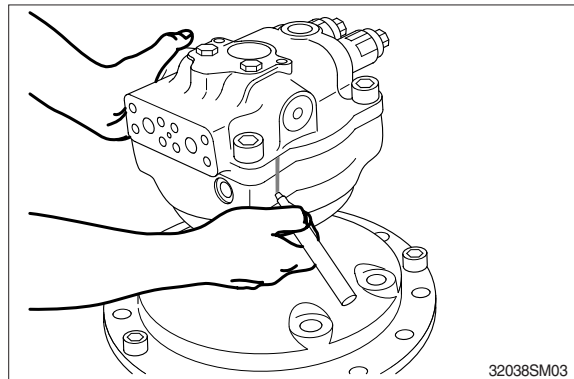

- (4) Remove the valve (052).

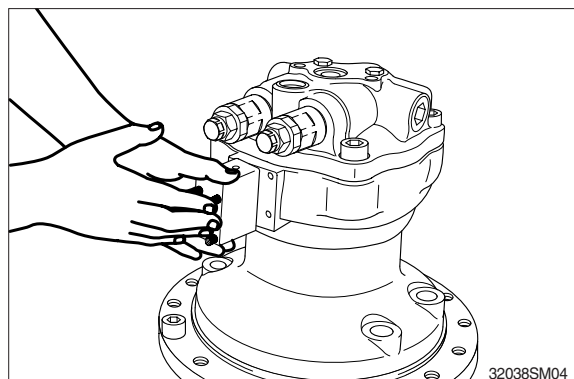

- (5) Remove the relief valve (051) from valve casing (303).

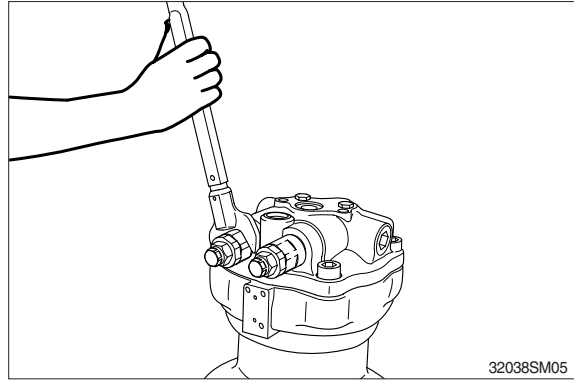

- (6) Remove plug (469) from valve casing (303) and spring (355), plunger (351).
※ Be careful not to damage the plunger seat assembly.

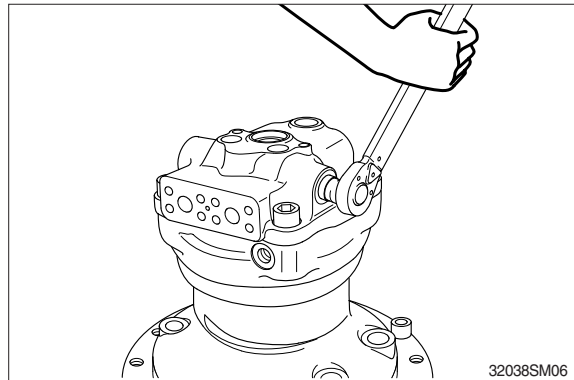

- (7) Remove valve casing (303) from casing (301). Then, remove the valve plate (131) from valve casing (303) with care.

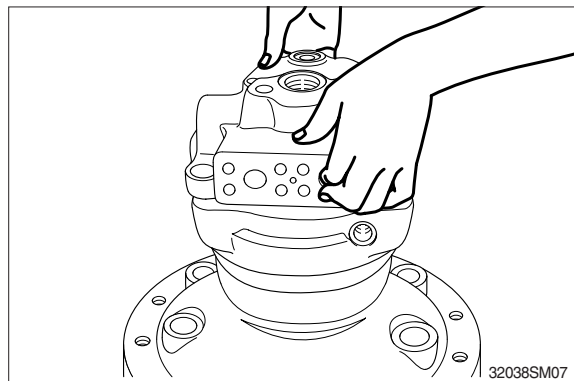

- (8) Remove the brake spring (712) from brake piston (702).

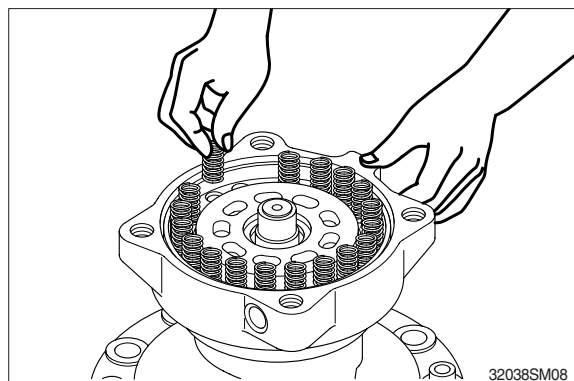

- (9) Remove brake piston (702) from casing (301).

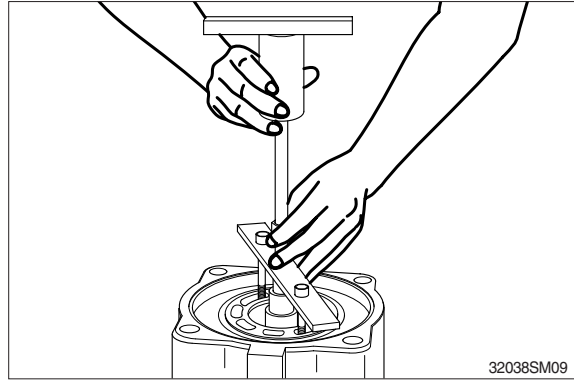

- (10) Remove the cylinder (111) from the output shaft (101) with the motor positioned horizontally. Remove piston (121), retainer (123), spherical bush (113), spacer (117) and shoe plate (124).

※ If shoe plate would not removed easily, try again after procedure (14).

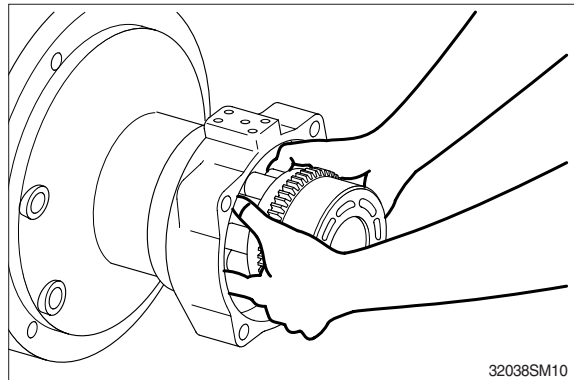

- (11) Remove friction plate (742) and separate plate (743) from casing (301).

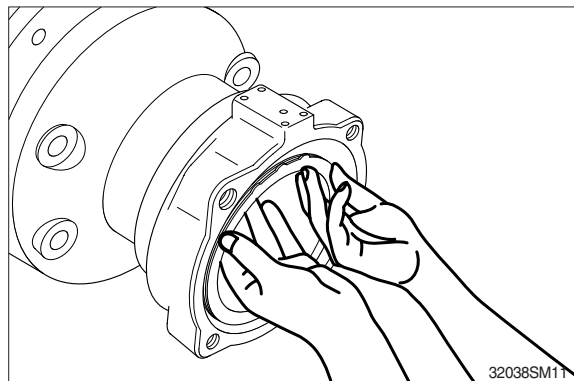

- (12) Remove snap ring (437) with pillar and remove the front cover (304) from casing (301).

※ Front cover could be removed with sliding shaft if necessary.

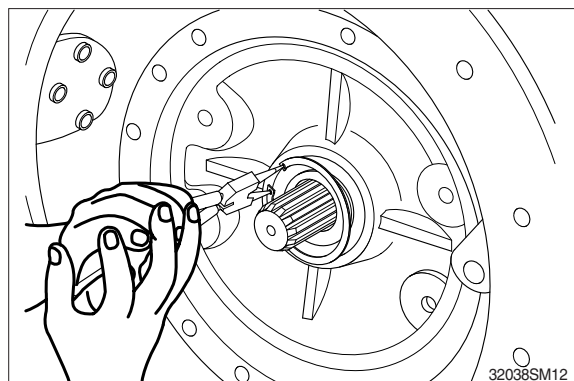

(13) Remove drive shaft (101) from casing (301).

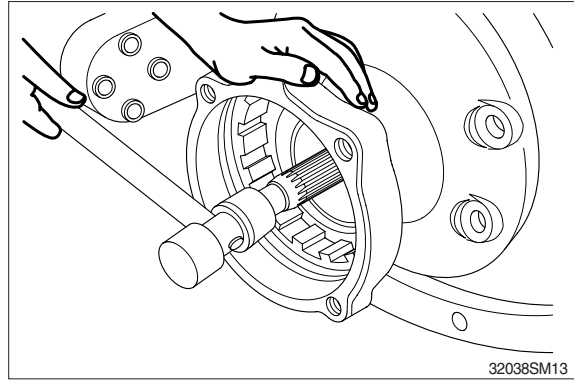

(14) Remove the shoe plate (124) from casing (301).

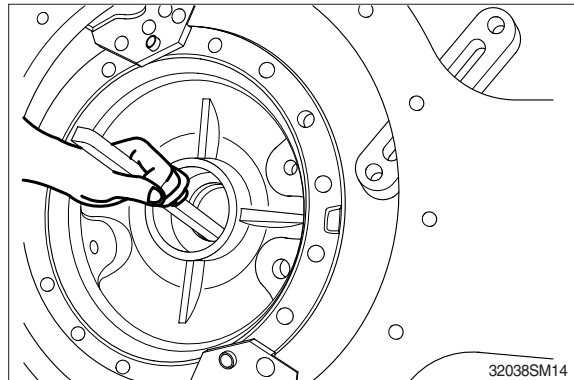

(15) Proceed with following job only when necessary.

- ① Remove the snap ring (432), spacer (106) from drive shaft (101) and remove the cone of roller bearing (443) by press.

※ Do not reuse bearings.

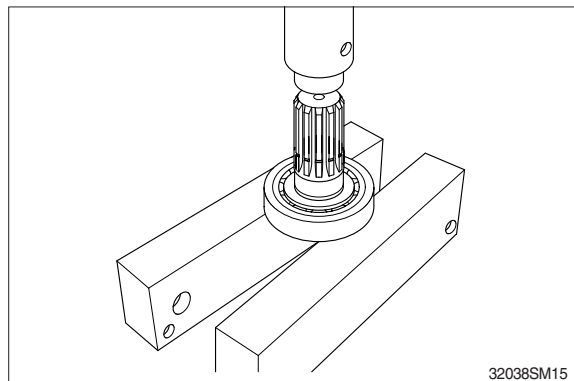
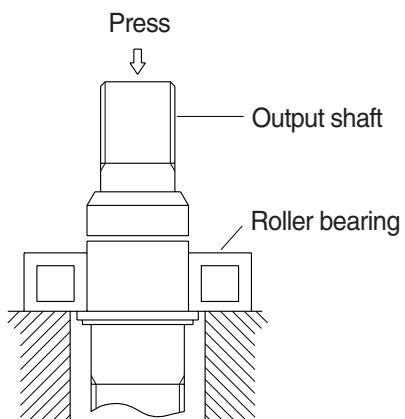

- ② Remove oil seal (491) from front cover (304).

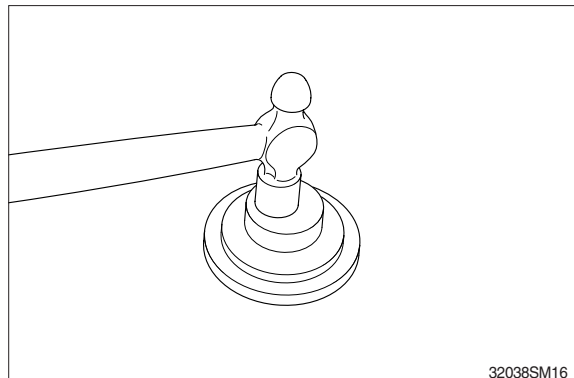

- ③ Remove the roller bearing (444) from the valve casing (303) by using slide hammer bearing puller.

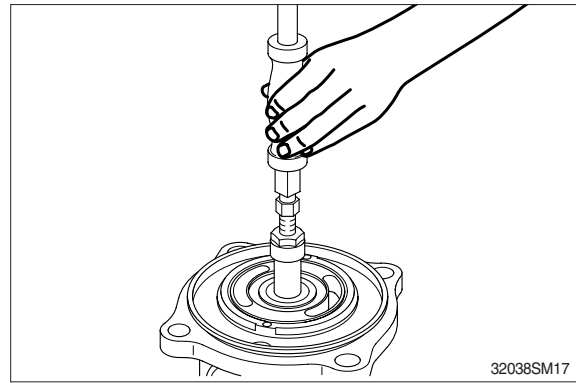

- ④ When disassembling the relief valve, release the plug (3). Remove the piston (7), spring seat (9), spring (8) and plunger (6) with the body (1) downwards.

※ Do not release the lock nut (15).

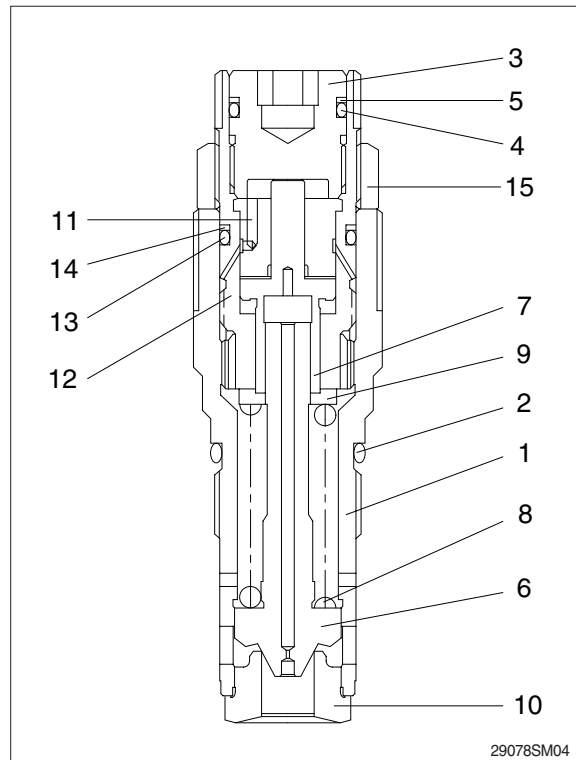

This completes disassembly.

3) ASSEMBLY

Do the reassembly in the reverse procedure of the disassembly.

- (1) Place the casing (301) on the workbench with the valve casing (303) downward.

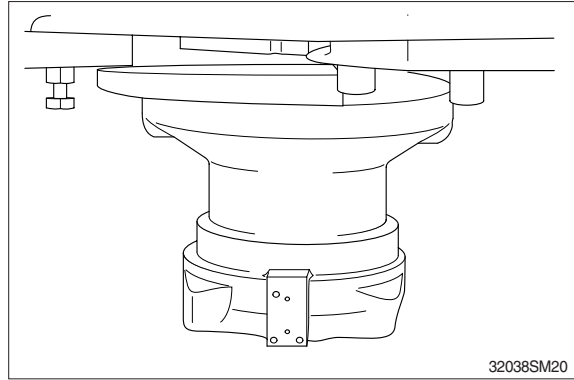

- (2) When reassembling the roller bearing, install the snap ring (432), and spacer (106) to the drive shaft (101). Insert the collar and cone of the roller bearing (443). Install the spacer (106) and stop ring (432). Install stop ring (433) to the output shaft (101) by heating the cone of the roller bearing (444).

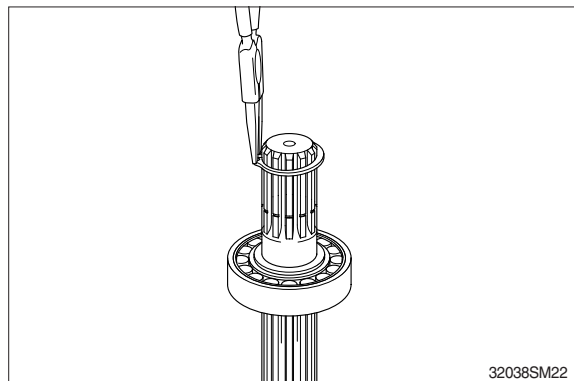
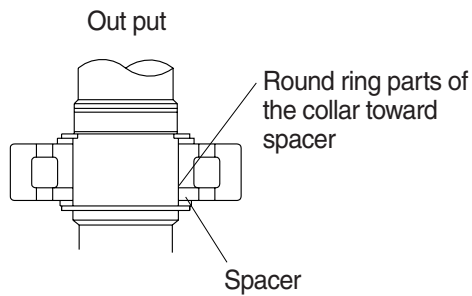
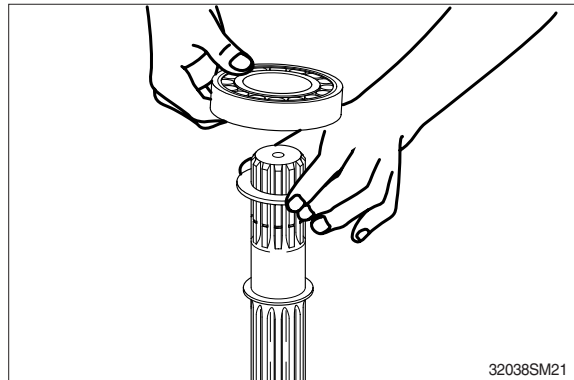

- (3) Insert the drive shaft (101) into the casing (301) with the end of output shaft upward and tap the outer race of roller bearing with the hammer.

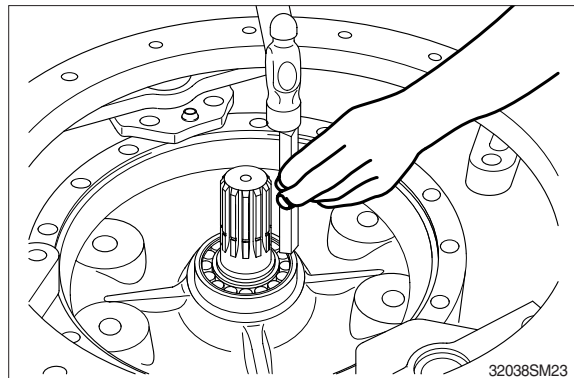

(4) Tack O-ring (471) to the casing (301).

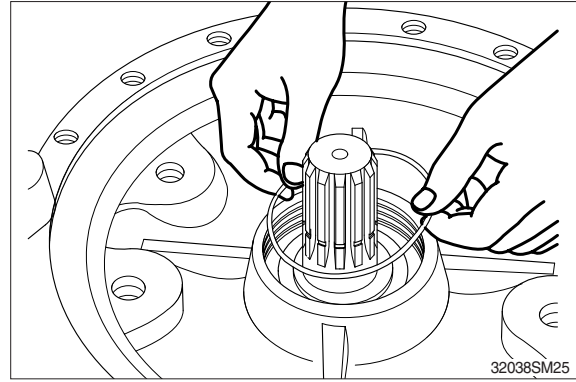

(5) Reassemble the front cover (304) to the casing (301).

※ Apply grease to the rib of oil seal to avoid damage to the rib.

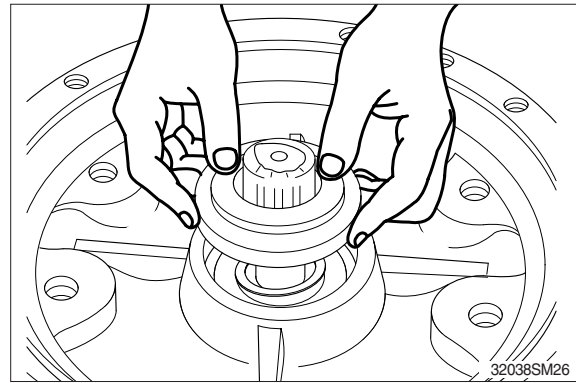

(6) Install the snap ring (437) to the casing (301).

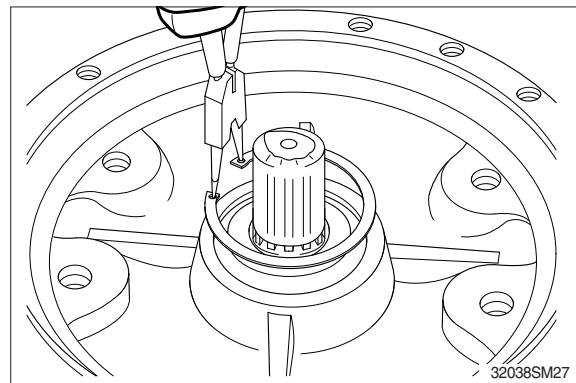

(7) Insert the shoe plate (124) with the casing (301) position horizontally.

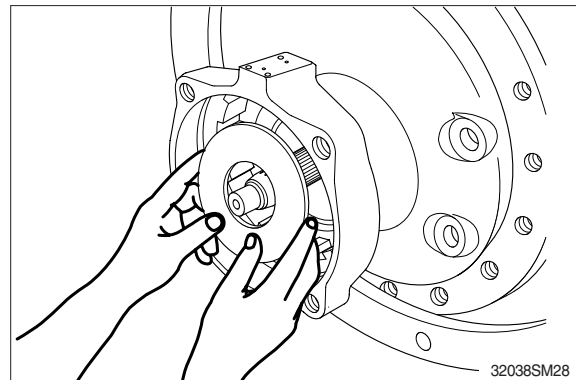

(8) Insert the push rod (116) into the cylinder (111). Place the retainer (113) assembled with spacer (117) onto the cylinder.

※ Insert two push rods in each hole.

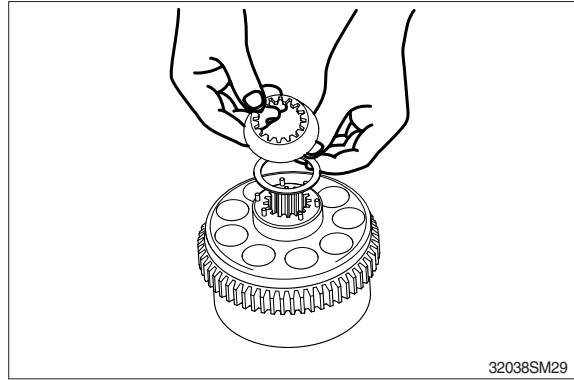

(9) Install the piston sub-assembly (121, 122) to the retainer (123).



(10) Reassemble the piston assembly (121, 122) to the cylinder block (111).

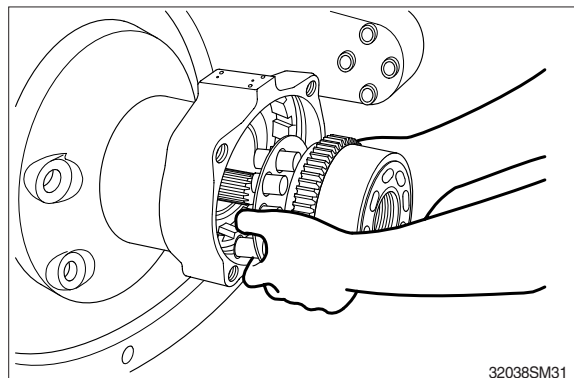

(11) Place the casing (301) under the front cover (304) and reassemble 3 sheets of separate plate (743) and then 2 sheets of friction plate (742) to the casing (301).

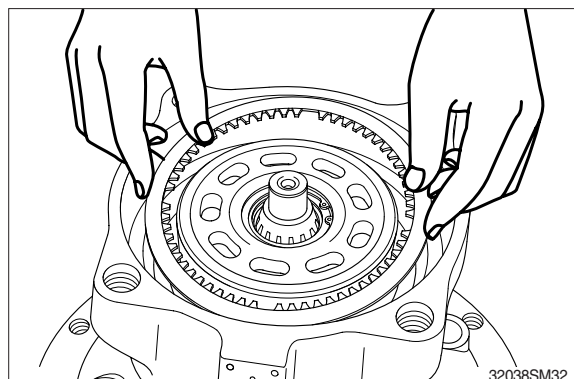

(12) Insert O-ring (706, 707) inside the casing (301).

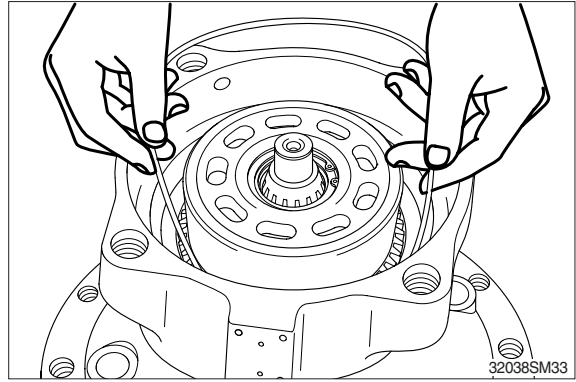

(13) Reassemble brake piston (702) to the casing (301).

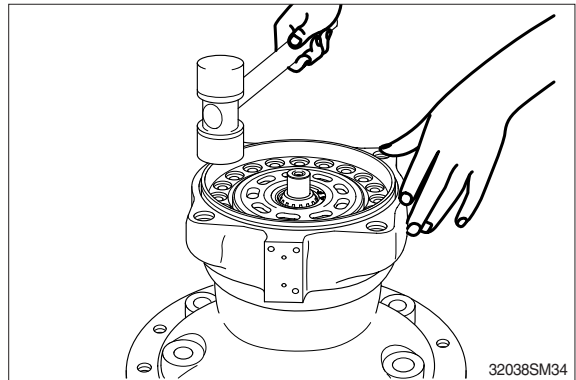

(14) Reassemble brake spring (712) to the brake piston (702).

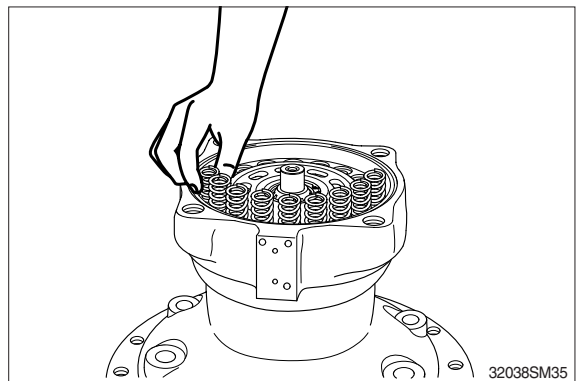

(15) When assembling the roller bearing (444), insert the roller bearing (444) into valve casing (303) by hammering.

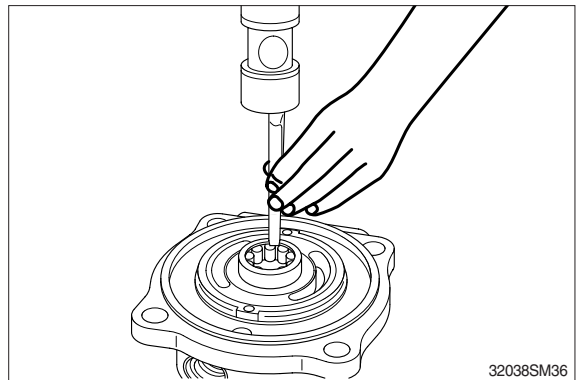

(16) Reassemble valve plate (131) to the valve casing (303) and reassemble O-ring (472).

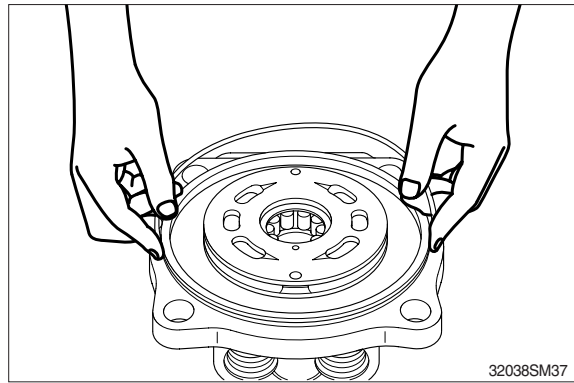

(17) Connect the valve casing (303) with the casing (301) and tighten the socket bolt (401).

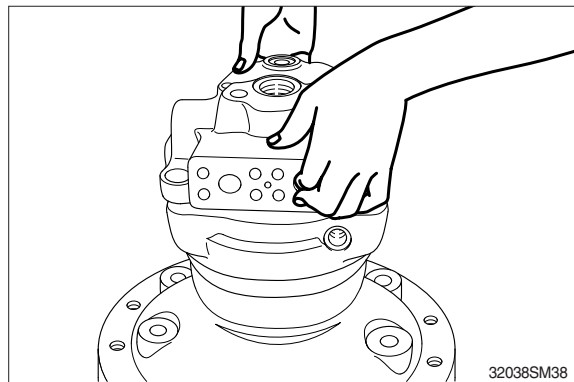

(18) Insert plunger (351) and spring (355) in the valve casing. Tighten plug (469) to the valve casing.

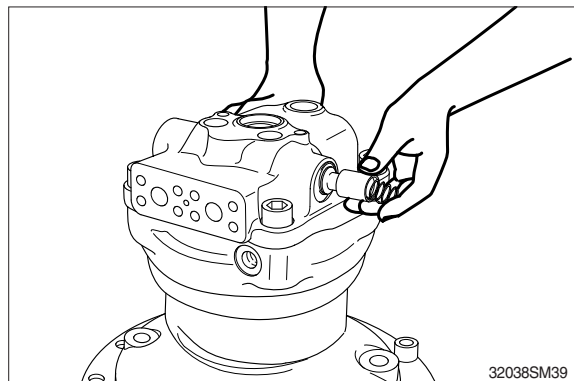

(19) Insert O-rings (051-1) to the relief valve (051) and reassemble them to valve casing (303).

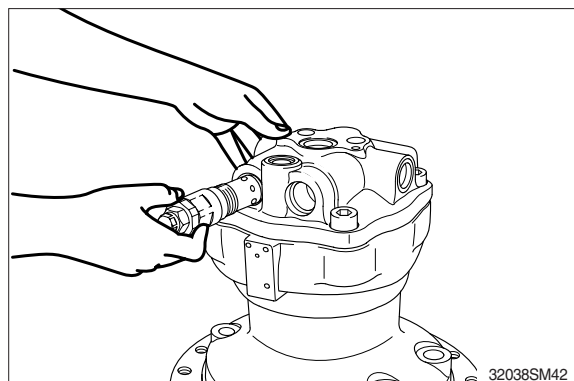

(20) Tighten the plug (464) to valve casing (303) to casing (301).

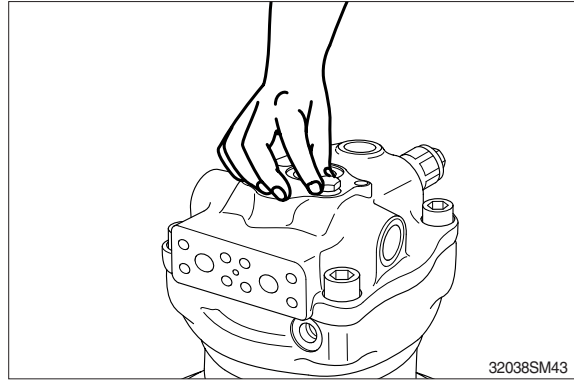

(21) Connect the valve casing (303) with the casing (301).

This completes assembly.

3. REMOVAL AND INSTALL OF REDUCTION GEAR

1) REMOVAL

- (1) Remove the swing motor assembly.
For details, see removal of swing motor assembly.
- (2) Sling reduction gear assembly(1) and remove mounting bolts(2).
- (3) Remove the reduction gear assembly.
 - Reduction gear device weight : 230 kg
(507 lb)



2) INSTALL

- (1) Carry out installation in the reverse order to removal.

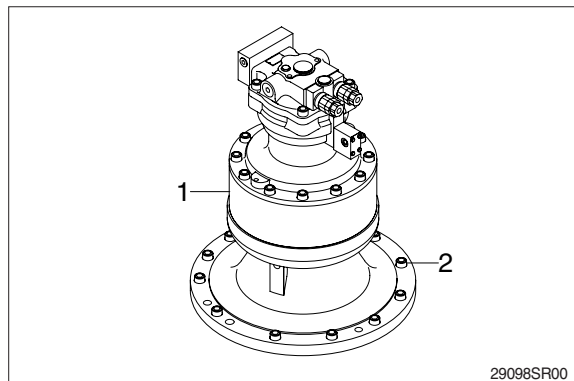

4. REDUCTION GEAR

1) STRUCTURE

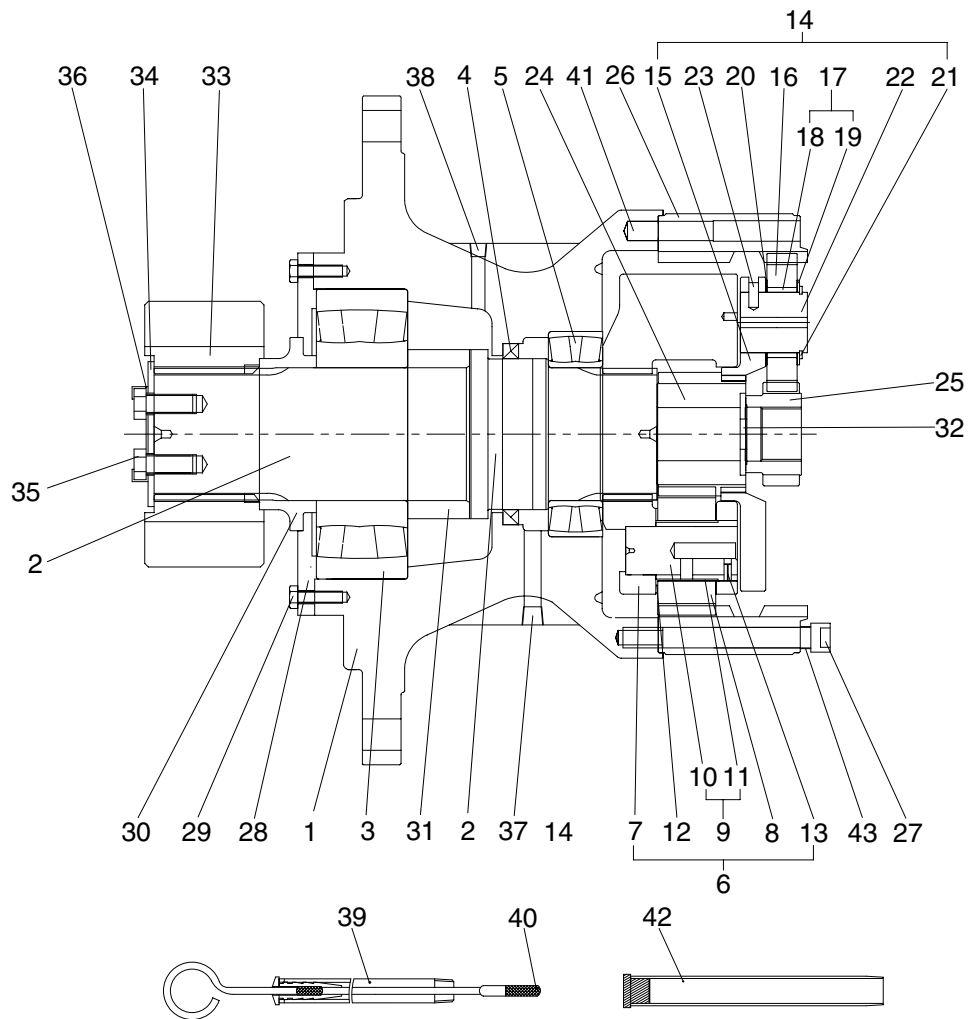

1	Casing	16	Planet gear 1	31	Spacer ring
2	Drive shaft	17	Pin assy 1	32	Thrust plate 3
3	Roller bearing	18	Pin 1	33	Pinion gear
4	Oil seal	19	Bushing 1	34	Lock plate
5	Roller bearing	20	Side plate 1	35	Hexagon bolt
6	Carrier assy 2	21	Side plate 2	36	Lock washer
7	Carrier 2	22	Stop ring	37	Plug
8	Planet gear 2	23	Spring pin	38	Plug
9	Pin assy 2	24	Sun gear 2	39	Gage pipe
10	Pin 2	25	Sun gear 1	40	Gage bar
11	Bushing 2	26	Ring gear	41	Knock pin
12	Thrust washer	27	Socket bolt	42	Air breather assy
13	Spring pin	28	Cover plate	43	Bushing 2
14	Carrier assy 1	29	Hexagon bolt		
15	Carrier 1	30	Spacer		

29092SM03

2) DISASSEMBLY

- (1) Removal of swing motor
Loosen the hexagonal socket bolt (27)
and remove swing motor.

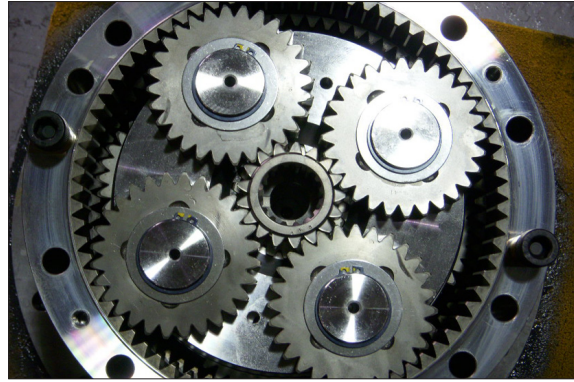

29098SR02

- (2) Removal of No.1 sun gear (25), No.3
thrust plate (32).
Install eye-bolt M10 to thread hole of No.1
carrier and remove No.1 carrier assembly
(14) itself.

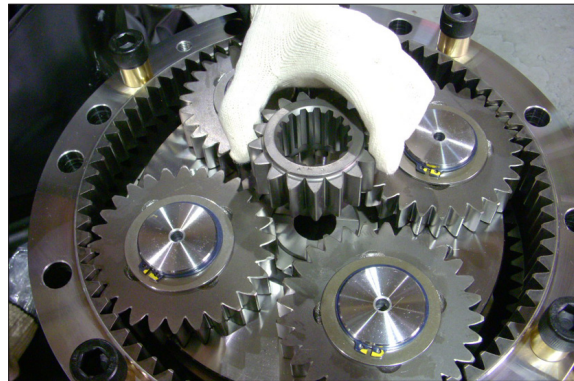

29098SR31

- (3) Removal of No.2 sun gear (24)
Install eye-bolt M10 to thread hole of No.2
carrier and remove No.2 carrier assembly
(6) itself.

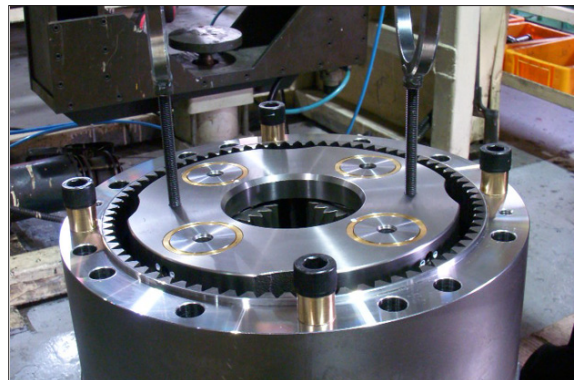

29098SR03A

- (4) Disassembly of No.2 carrier assembly (6)
- ① Place the proper tool on spring pin (13),
and then insert spring pin (13) until the
center of No.2 pin (10) with hammer.
- ※ Do not reuse spring pin (13) after
removal.

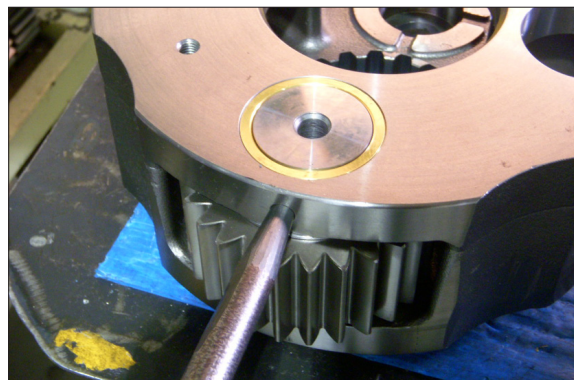

29098SR04

- ② Remove No.2 pin assy (9) and then pull out No.2 planet gear (8) and thrust washer (12) with hands.



29098SR05

- (5) Removal of ring gear(26)
Remove ring gear (26) from casing (1).
※ Liquid gasket is applied on contacting surface of ring gear (26) and casing (1) to prevent gear oil from leaking.
Therefore, remove ring gear (26) from casing (1) by minus screw driver through grooves of casing (1).

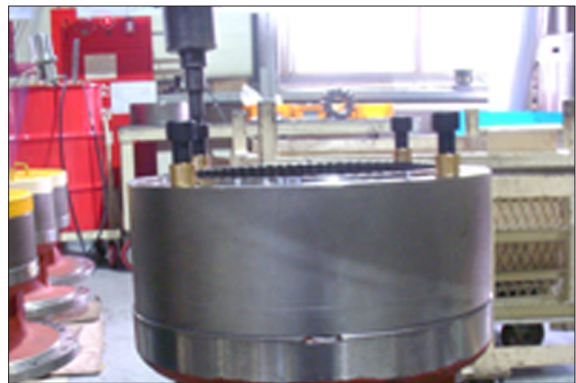

29098SR06

- (6) Removal of pinion gear (33)
Remove hexagon head bolt (35), lock washer (36), hexagon head bolt (35), lock plate(34), pinion gear (33), spacer(30) and cover plate (28) when pinion gear (33) is not disassembled from drive shaft (2) easily. Use rubber hammer to the pinion gear (33)



29098SR07



29098SR08

(7) Removal of drive shaft (2)

- ① Install a support under flange surface area of casing (1).

Install hydraulic press to the end surface of drive shaft (2) and remove the drive shaft (2) with roller bearing (3) and spacer ring (31).

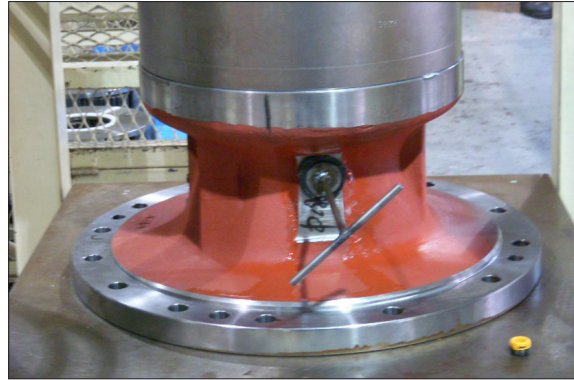

29098SR09

- ② Remove roller bearing (3) and spacer ring (31) from drive shaft (2).



29098SR10

- ③ Remove roller bearing (5), oil seal (4) from casing (1)

※ Do not reuse oil seal (4).

※ Drive shaft assembly is only disassembled when roller bearing is needed to be replaced due to wear, oil leaking.



29098SR11

3) ASSEMBLY

(1) Assembly of drive shaft (2) and parts

① After assemble spacer ring (31) to drive shaft (2) hydraulic press fit roller bearing (3) to drive shaft (2).

② Heat roller bearing up to 80~90°C plus surrounding temperature and remove magnetism for 5 minutes.

Assemble it to drive shaft (2) with hydraulic press and then assemble spacer ring (31) in this order.

※ Pay attention to the assembling direction of spacer ring (31).

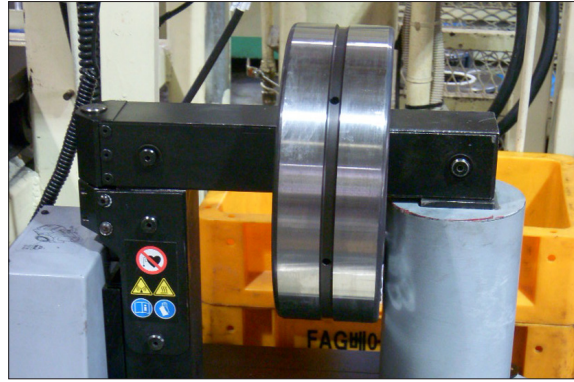

29098SR12



29098SR13

(2) Installation of oil seal(4)

Remove oil from oil seal (4) and the surface area of casing (1) to which oil seal (4) is to be assembled.

Assemble oil seal to the casing (1) with press fitting jig and then apply grease to the rib of oil seal (4).



29098SR14



29098SR15

(3) Assembly of drive shaft (2) and parts

- ① Place the output parts of casing (1) upward.

Install eye-bolt M16 into the thread hole of the output end surface of drive shaft assembly.

- ② Lift drive shaft assembly using the eye-bolts and then assemble that to casing (1).



29098SR16

(4) Install of roller bearing (5)

Place the output part of casing assembly down ward.

Heat roller bearing (5) up to 80~90°C plus surrounding temperature and remove magnetism for 5 minutes assemble it the drive shaft (2).



29098SR17

(5) Assembly of pinion gear (33)

- ① Assemble cover plate (28), hexagon bolt (35) to casing (1).

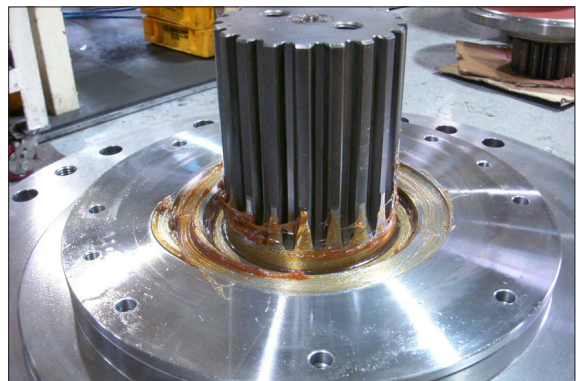

29098SR18

- ② After assemble spacer (30), pinion gear (33), lock plate (34) and lock washer (36) tighten hexagon bolt (35).



29098SR19

- ③ Corner (4 places) of lock washer (36) bent in direction of the hexagon bolt (35) head.

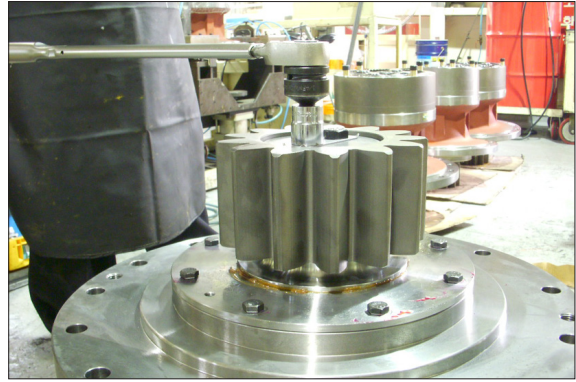

29098SR20



29098SR21

(6) Assembly of ring gear (26)

- ① Remove oil from mating surfaces between casing (1) and ring gear (26) and from knock pin (41). Liquid gasket (three bond No. 1194 equivalent) around socket bolt (27) hole at casing.



29098SR22

- ② Assemble ring gear (26) to casing assembly correctly using lock pin hole as guide.



29098SR23

(7) Assembly of No.2 carrier assembly (6)

- ① Assemble No.2 planet gear (8) to No.2 carrier (7) with thrust washer (12) and insert No.2 pin (10) correctly and No.2 pin (10) is around with spring pin hole at No.2 carrier (7).

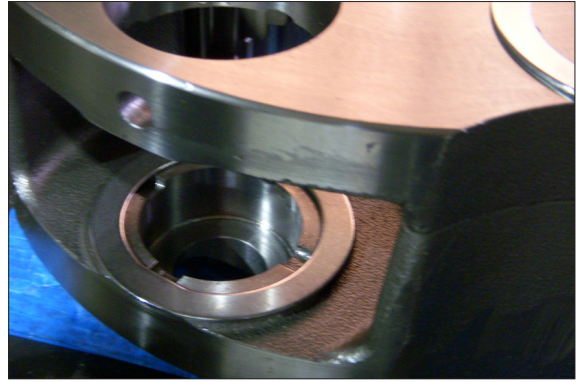

29098SR24

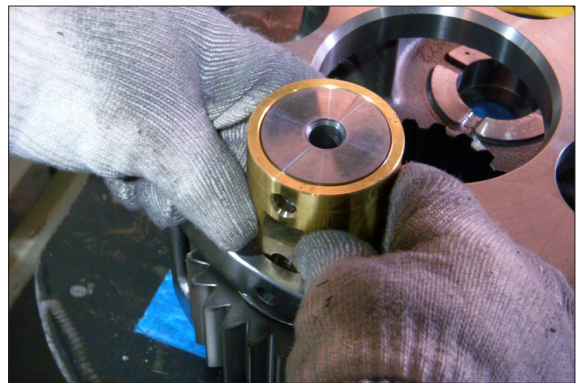

29098SR25

- ② Insert spring pin (13) into No.2 carrier (7) hole and No.2 pin (10) hole.



29098SR26

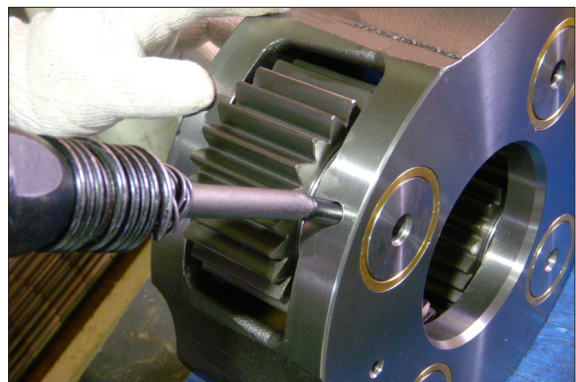

29098SR27

(8) Assembly of No.2 carrier assembly (6)

- ① Install eye bolt into thread hole M10 of No.2 carrier (7) and lift No.2 carrier assembly (6) using the eye-bolt.

And then insert No.2 carrier assembly (6) being engaged with internal teeth of ring gear (26).

Rotate carrier assembly lightly so that splines of drive shaft (2) are engaged.

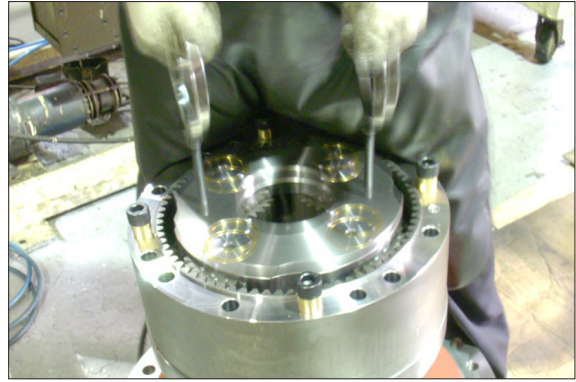

29098SR28

- ② Insert No.2 sun gear (25) into No.2 planet gear (8).



29098SR29

(9) Assembly of No.1 carrier assembly (14)

- ① Mount eye bolt into thread hole M10 of No.1 carrier assembly (14) and lift the assembly using the eye-bolt and then insert No.1 carrier assembly (14) being engaged with internal teeth of ring gear (26).

- ② Rotate No.1 carrier assembly (14) lightly so that No.2 sun gear (24) is engaged with teeth No.1 carrier assembly (14).



29098SR30

- ③ Insert No.1 sun gear (25) into No.1 planet gear (16).

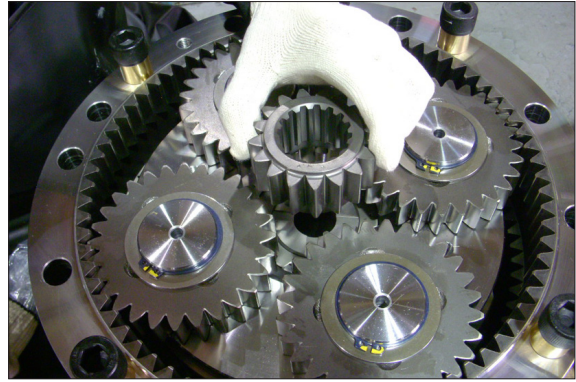

29098SR31

- (10) Check smoothness of gear rotation by turning No.1 carrier assy (14).

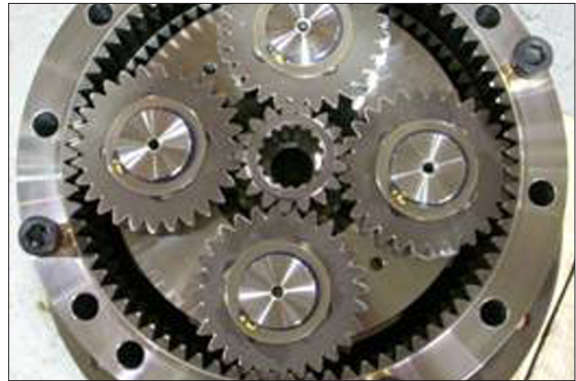

29098SR32

- (11) Assembly of swing motor

- ① Remove oil from mating surfaces between ring gear (26) and swing motor and apply liquid gasket (three bond No.1194 equivalent) around socket bolt hole at ring gear.

Assemble swing motor and tighten socket bolt (27) with 18mm hexagonal socket.

- Tightening torque : 34 kgf·m (246 lbf·ft)