

GROUP 2 SPECIFICATIONS

1. MAJOR COMPONENT

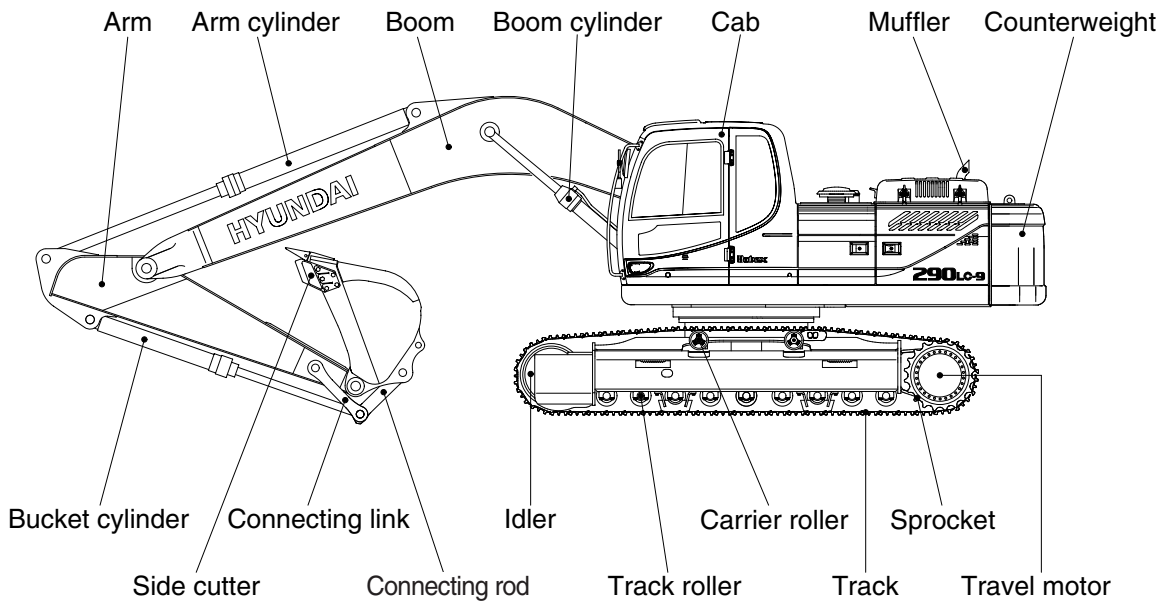
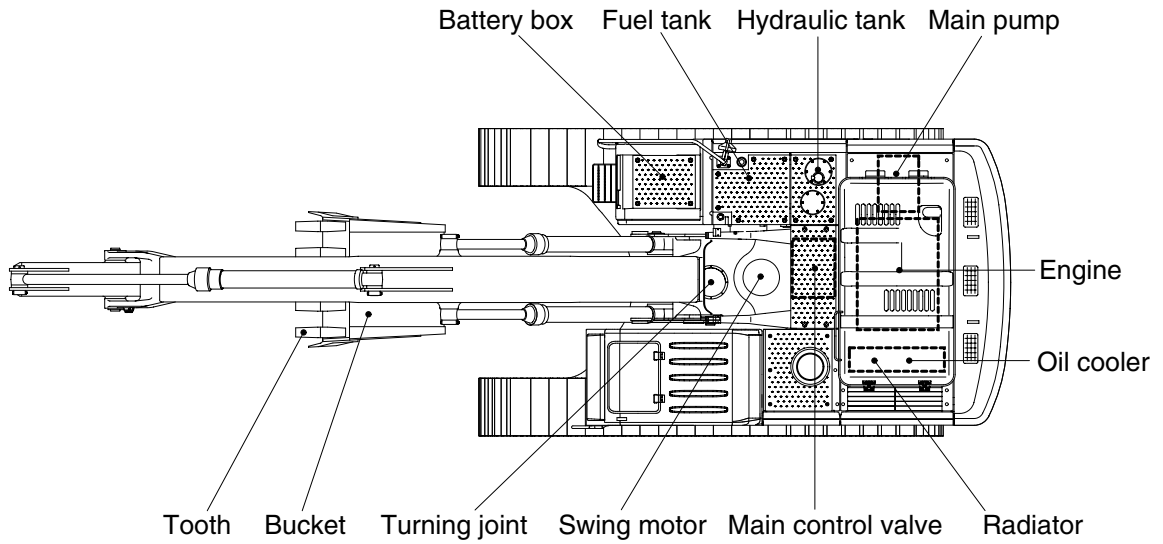

29092SP01A

2. SPECIFICATIONS

1) R290LC-9

·6.25 m (20' 6") BOOM and 3.05 m (10' 0") ARM

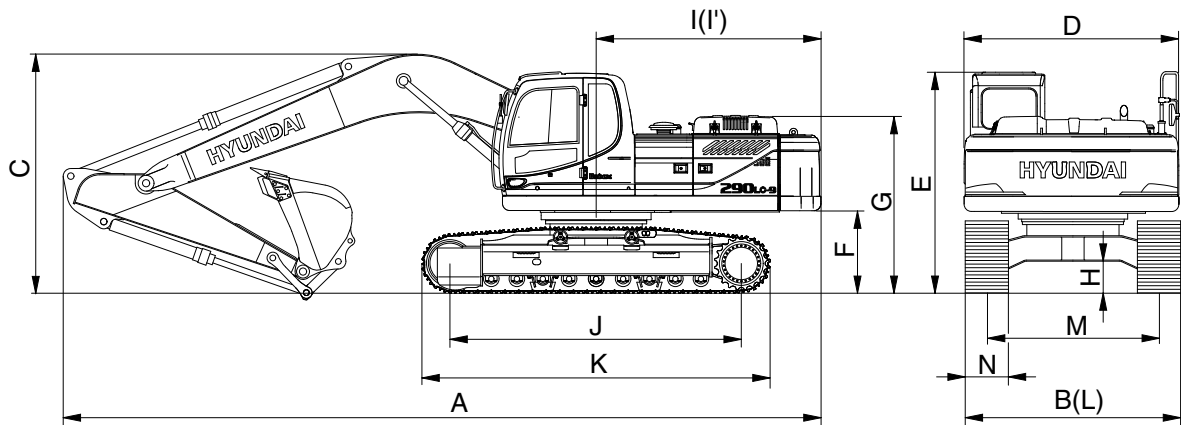

29092SP02

Description		Unit	Specification
Operating weight		kg (lb)	29700 (65480)
Bucket capacity (SAE heaped), standard		m ³ (yd ³)	1.27 (1.66)
Overall length	A	mm (ft-in)	10560 (34' 8")
Overall width, with 600mm shoe	B		3200 (10' 6")
Overall height	C		3290 (10' 10")
Superstructure width	D		2980 (9' 9")
Overall height of cab	E		3010 (9' 11")
Ground clearance of counterweight	F		1190 (3' 11")
Engine cover height	G		3190 (10' 6")
Minimum ground clearance	H		500 (1' 8")
Rear-end distance	I		3120 (10' 3")
Rear-end swing radius	I'		3200 (10' 6")
Distance between tumblers	J		4030 (13' 3")
Undercarriage length	K		4940 (16' 2")
Undercarriage width	L		3200 (10' 6")
Track gauge	M		2600 (8' 6")
Track shoe width, standard	N		600 (24")
Travel speed (low/high)			km/hr (mph)
Swing speed		rpm	10.2
Gradeability		Degree (%)	35 (70)
Ground pressure (600 mm shoe)		kgf/cm ² (psi)	0.57 (8.11)
Max traction force		kg (lb)	27300 (60200)

2) R290NLC-9

·6.25 m (20' 6") BOOM and 3.05 m (10' 0") ARM

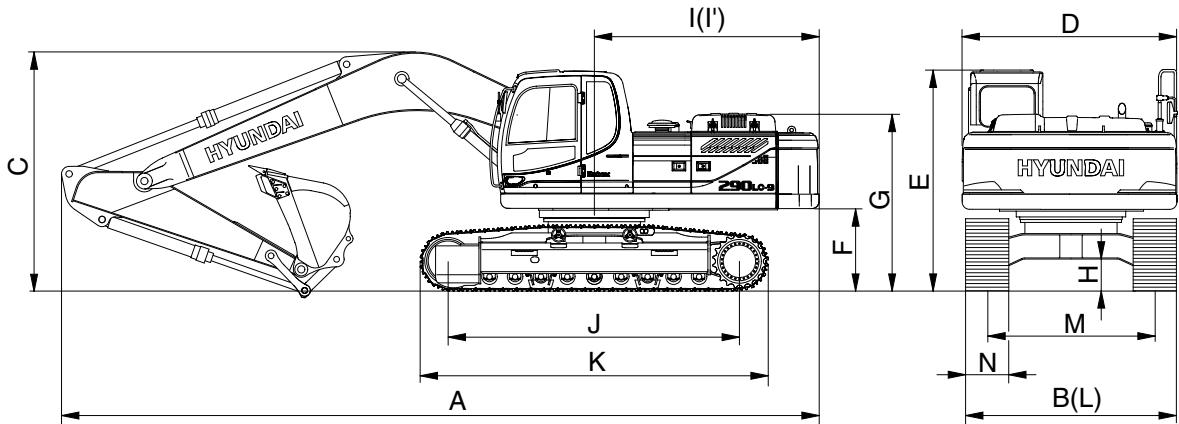

29092SP08

Description		Unit	Specification
Operating weight		kg (lb)	29100 (64150)
Bucket capacity (SAE heaped), standard		m ³ (yd ³)	1.27 (1.66)
Overall length	A	mm (ft-in)	10560 (34' 8")
Overall width, with 600mm shoe	B		2990 (9' 10")
Overall height	C		3290 (10' 10")
Superstructure width	D		2980 (9' 9")
Overall height of cab	E		3010 (9' 11")
Ground clearance of counterweight	F		1190 (3' 11")
Engine cover height	G		3190 (10' 6")
Minimum ground clearance	H		500 (1' 8")
Rear-end distance	I		3120 (10' 3")
Rear-end swing radius	I'		3200 (10' 6")
Distance between tumblers	J		4030 (13' 3")
Undercarriage length	K		4940 (16' 2")
Undercarriage width	L		2990 (9' 10")
Track gauge	M		2390 (7' 10")
Track shoe width, standard	N		600 (24")
Travel speed (low/high)			km/hr (mph)
Swing speed		rpm	10.2
Gradeability		Degree (%)	35 (70)
Ground pressure (600 mm shoe)		kgf/cm ² (psi)	0.55 (7.82)
Max traction force		kg (lb)	27300 (60200)

3) R290LC-9 LONG REACH

· 10.2 m (33' 6") BOOM and 7.85 m (25' 9") ARM

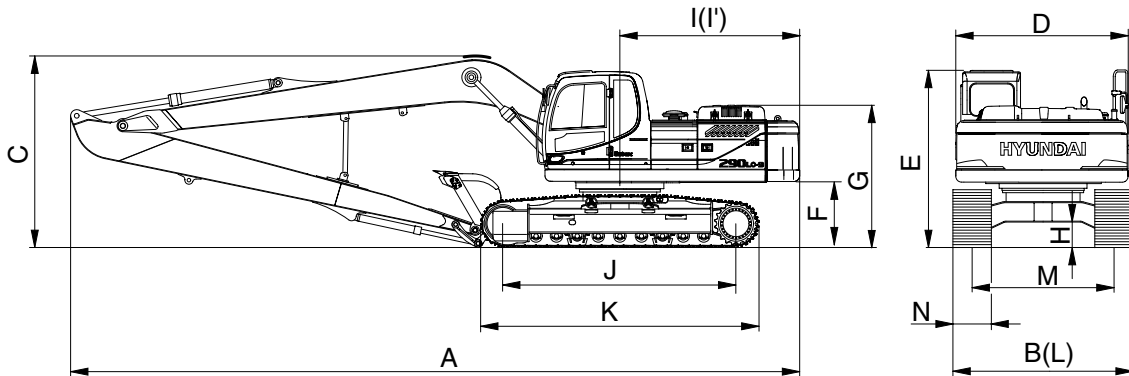

29092SP03

Description		Unit	Specification
Operating weight		kg (lb)	32690 (72630)
Bucket capacity (SAE heaped), standard		m ³ (yd ³)	0.52 (0.68)
Overall length	A	mm (ft-in)	14550 (47' 9")
Overall width, with 800 mm shoe	B		3400 (11' 2")
Overall height	C		3550 (11' 8")
Superstructure width	D		2980 (9' 9")
Overall height of cab	E		3010 (9' 11")
Ground clearance of counterweight	F		1190 (3' 11")
Engine cover height	G		3190 (10' 6")
Minimum ground clearance	H		500 (1' 8")
Rear-end distance	I		3120 (10' 3")
Rear-end swing radius	I'		3200 (10' 6")
Distance between tumbler	J		4030 (13' 3")
Undercarriage length	K		4940 (16' 2")
Undercarriage width	L		3400 (11' 2")
Track gauge	M		2600 (8' 6")
Track shoe width, standard	N		800 (31' 5")
Travel speed (low/high)			km/hr (mph)
Swing speed		rpm	10.2
Gradeability		Degree (%)	35 (70)
Ground pressure (800 mm shoe)		kgf/cm ² (psi)	0.47 (6.68)
Max traction force		kg (lb)	27300 (60200)

4) R290LC-9 HIGH WALKER

·6.25 m (20' 6") BOOM and 3.05 m (10' 0") ARM

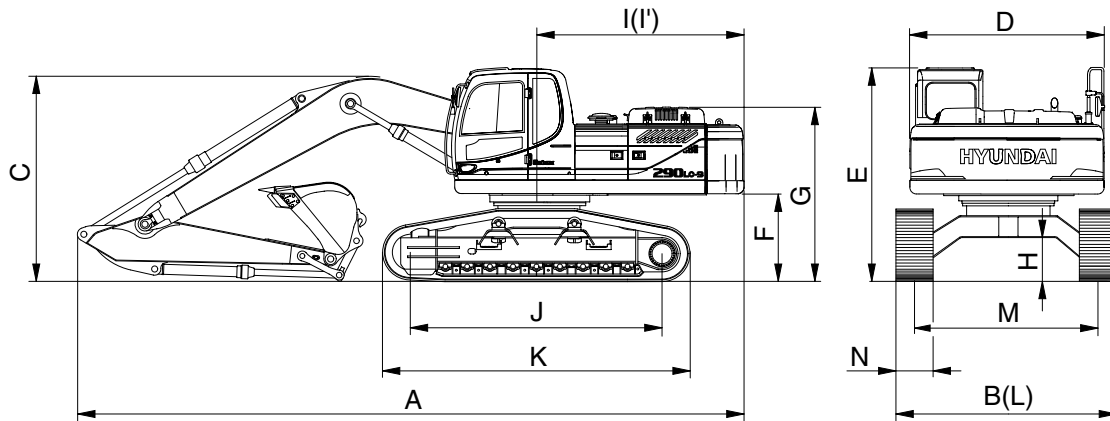

29092SP04

Description		Unit	Specification
Operating weight		kg (lb)	32140 (70860)
Bucket capacity (SAE heaped), standard		m ³ (yd ³)	1.27 (1.66)
Overall length	A	mm (ft-in)	10430 (34' 3")
Overall width, with 600 mm shoe	B		3470 (11' 5")
Overall height	C		3350 (11' 0")
Superstructure width	D		2980 (9' 9")
Overall height of cab	E		3380 (11' 1")
Ground clearance of counterweight	F		1500 (4' 11")
Engine cover height	G		3500 (11' 6")
Minimum ground clearance	H		765 (2' 6")
Rear-end distance	I		3120 (10' 3")
Rear-end swing radius	I'		3200 (10' 6")
Distance between tumbler	J		4030 (13' 3")
Undercarriage length	K		4950 (16' 3")
Undercarriage width	L		3470 (11' 5")
Track gauge	M		2870 (9' 5")
Track shoe width, standard	N		600 (23' 6")
Travel speed (low/high)			km/hr (mph)
Swing speed		rpm	10.2
Gradeability		Degree (%)	35 (70)
Ground pressure (600 mm shoe)		kgf/cm ² (psi)	0.62 (8.82)
Max traction force		kg (lb)	27300 (60200)

3. WORKING RANGE

1) R290LC-9, R290NLC-9

·6.25 m (20' 6") BOOM

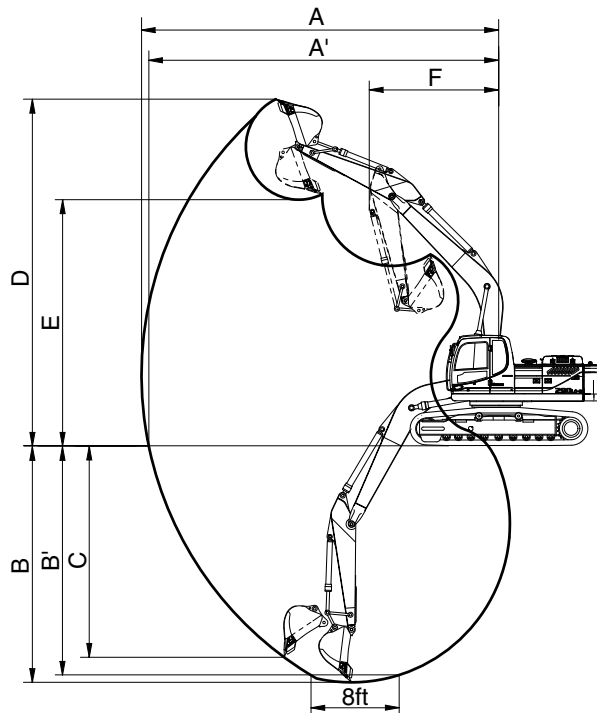

29092SP05

Description		2.10m (6' 11") Arm	2.50 m (8' 2") Arm	3.05 m (10' 0") Arm	3.75 m (12' 4") Arm
Max digging reach	A	10020 mm (32' 10")	10280 mm (33' 7")	10820 mm (35' 6")	11400 mm (37' 5")
Max digging reach on ground	A'	9820 mm (32' 3")	10080 mm (33' 1")	10620 mm (34' 10")	11220 mm (36' 10")
Max digging depth	B	6440 mm (21' 1")	6840 mm (22' 5")	7390 mm (24' 3")	8090 mm (26' 7")
Max digging depth (8 ft level)	B'	6240 mm (20' 6")	6630 mm (21' 9")	7300 mm (23' 11")	7920 mm (25' 12")
Max vertical wall digging depth	C	6000 mm (19' 8")	5850 mm (19' 2")	6380 mm (20' 11")	7080 mm (23' 3")
Max digging height	D	10070 mm (33' 0")	10110 mm (33' 2")	10160 mm (33' 4")	10360 mm (33' 12")
Max dumping height	E	6940 mm (22' 9")	7030 mm (23' 1")	7110 mm (23' 4")	7310 mm (23' 12")
Min swing radius	F	4380 mm (14' 4")	4260 mm (13' 12")	4230 mm (13' 11")	4140 mm (13' 7")
Bucket digging force	SAE	166.7 [181] kN	166.7 [181] kN	166.7 [181] kN	166.7 [181] kN
		17000 [18460] kgf	17000 [18460] kgf	17200 [18460] kgf	17000 [18460] kgf
		37480 [40690] lbf	37480 [40690] lbf	37920 [40690] lbf	37480 [40690] lbf
	ISO	189.3 [205.5] kN	189.3 [205.5] kN	189.3 [205.5] kN	189.3 [205.5] kN
		19300 [20950] kgf	19300 [20950] kgf	19300 [20950] kgf	19300 [20950] kgf
		42550 [46200] lbf	42550 [46200] lbf	42550 [46200] lbf	42550 [46200] lbf
Arm digging force	SAE	180.4 [195.9] kN	156.9 [170.4] kN	131.4 [142.7] kN	114.7 [124.6] kN
		18400 [19980] kgf	16000 [17370] kgf	13400 [14550] kgf	11700 [12700] kgf
		40570 [44050] lbf	35270 [38290] lbf	29540 [32070] lbf	25790 [28000] lbf
	ISO	190.3 [206.6] kN	163.8 [177.8] kN	136.3 [148] kN	119.6 [129.9] kN
		19400 [21060] kgf	16700 [18130] kgf	13900 [15090] kgf	12200 [13250] kgf
		42770 [46440] lbf	36820 [39980] lbf	30640 [33270] lbf	26900 [29210] lbf

[] : Power boost

2) R290LC-9 LONG REACH

· 10.2 m (33' 6") BOOM

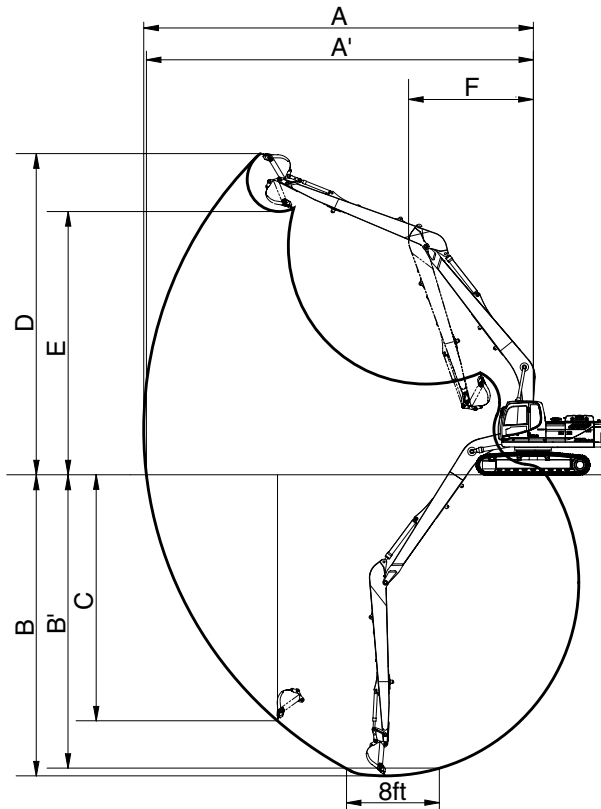

29092SP06

Description		7.85 m (25' 9") Arm
Max digging reach	A	18510 (60' 9")
Max digging reach on ground	A'	18400 (60' 4")
Max digging depth	B	14820 (48' 7")
Max digging depth (8 ft level)	B'	14690 (48' 2")
Max vertical wall digging depth	C	12020 (39' 5")
Max digging height	D	14500 (47' 7")
Max dumping height	E	12190 (39' 12")
Min swing radius	F	6250 (20' 6")
Bucket digging force	SAE	70 kN
		7100 kgf
		15650 lbf
	ISO	80 kN
		8200 kgf
		18080 lbf
Arm crowd force	SAE	47.1 kN
		4800 kgf
		10580 lbf
	ISO	48.1 kN
		4900 kgf
		10800 lbf

3) R290LC-9 HIGH WALKER

·6.25 m (20' 6") BOOM

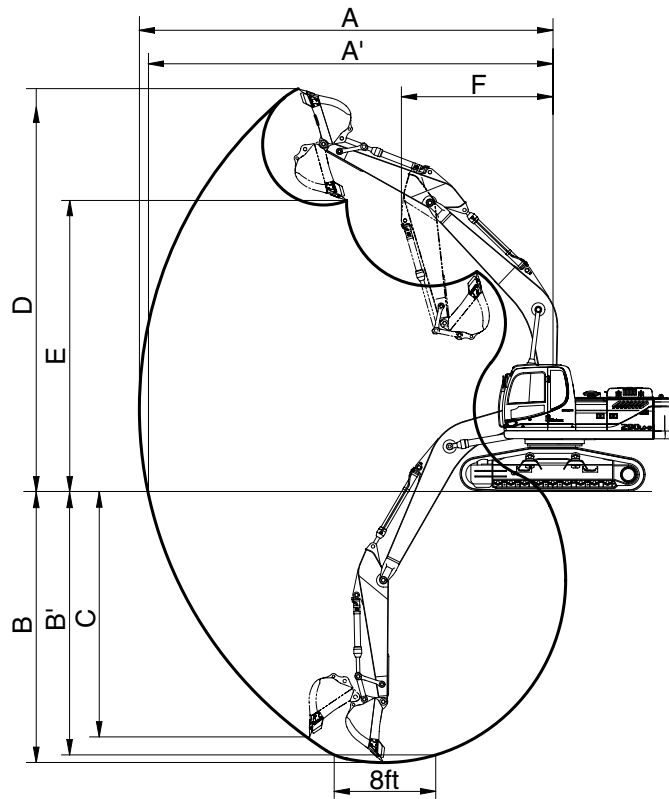

29092SP07

Description		2.10m (6' 11") Arm	2.50 m (8' 2") Arm	3.05 m (10' 0") Arm	3.75 m (12' 4") Arm
Max digging reach	A	10020 mm (32' 10")	10280 mm (33' 7")	10790 mm (35' 5")	11400 mm (37' 5")
Max digging reach on ground	A'	9750 mm (32' 0")	10020 mm (32' 10")	10530 mm (34' 7")	11160 mm (36' 7")
Max digging depth	B	6140 mm (20' 2")	6540 mm (21' 5")	7090 mm (23' 3")	7790 mm (25' 7")
Max digging depth (8 ft level)	B'	5930 mm (19' 5")	6330 mm (20' 9")	6910 mm (22' 8")	7630 mm (25' 0")
Max vertical wall digging depth	C	5700 mm (18' 8")	5560 mm (18' 3")	6090 mm (20' 0")	6790 mm (22' 3")
Max digging height	D	10370 mm (34' 0")	10220 mm (33' 6")	10440 mm (34' 3")	10660 mm (35' 0")
Max dumping height	E	7240 mm (23' 9")	7170 mm (23' 6")	7400 mm (24' 3")	7610 mm (25' 0")
Min swing radius	F	4380 mm (14' 4")	4260 mm (14' 0")	4230 mm (13' 11")	4140 mm (13' 7")
Bucket digging force	SAE	166.7 [181] kN	166.7 [181] kN	166.7 [181] kN	166.7 [181] kN
		17000 [18460] kgf	17000 [18460] kgf	17000 [18460] kgf	17000 [18460] kgf
		37480 [40690] lbf	37480 [40690] lbf	37480 [40690] lbf	37480 [40690] lbf
	ISO	189.3 [205.5] kN	189.3 [205.5] kN	189.3 [205.5] kN	189.3 [205.5] kN
		19300 [20950] kgf	19300 [20950] kgf	19300 [20950] kgf	19300 [20950] kgf
		42550 [46200] lbf	42550 [46200] lbf	42550 [46200] lbf	42550 [46200] lbf
Arm digging force	SAE	180.4 [195.9] kN	156.9 [170.4] kN	131.4 [142.7] kN	114.7 [124.6] kN
		18400 [19980] kgf	16000 [17370] kgf	13400 [14550] kgf	11700 [12700] kgf
		40570 [44050] lbf	35270 [38290] lbf	29540 [32070] lbf	25790 [28000] lbf
	ISO	190.3 [206.6] kN	163.8 [177.8] kN	136.3 [148] kN	119.6 [129.9] kN
		19400 [21060] kgf	16700 [18130] kgf	13900 [15090] kgf	12200 [13250] kgf
		42770 [46440] lbf	36820 [39980] lbf	30640 [33270] lbf	26900 [29210] lbf

[] : Power boost

4. WEIGHT

1) R290LC-9, R290NLC-9

Item	R290LC-9		R290NLC-9	
	kg	lb	kg	lb
Upperstructure assembly	12610	27800	←	←
Main frame weld assembly	2670	5890	←	←
Engine assembly	556	1230	←	←
Main pump assembly	140	310	←	←
Main control valve assembly	220	490	←	←
Swing motor assembly	390	860	←	←
Hydraulic oil tank assembly	250	560	←	←
Fuel tank assembly	240	530	←	←
Counterweight	5200	11460	←	←
Cab assembly	490	1080	←	←
Lower chassis assembly	10740	23680	10600	23370
Track frame weld assembly	3765	8300	3625	7990
Swing bearing	430	950	←	←
Travel motor assembly	400	880	←	←
Turning joint	54	120	←	←
Track recoil spring	205	450	←	←
Idler	252	560	←	←
Carrier roller	35	80	←	←
Track roller	54	119	←	←
Track-chain assembly (600 mm standard triple grouser shoe)	1860	4110	←	←
Front attachment assembly (6.25 m boom, 3.05 m arm, 1.27 m ³ SAE heaped bucket)	5550	12240	←	←
6.25 m boom assembly	2285	5040	←	←
3.05 m arm assembly	1025	2260	←	←
1.27 m ³ SAE heaped bucket	1010	2230	←	←
Boom cylinder assembly	270	600	←	←
Arm cylinder assembly	360	790	←	←
Bucket cylinder assembly	220	485	←	←
Bucket control link assembly	110	240	←	←

2) R290LC-9 LONG REACH

Item	R290LC-9 LONG REACH	
	kg	lb
Upperstructure assembly	14410	31810
Main frame weld assembly	2670	5890
Engine assembly	556	1230
Main pump assembly	140	310
Main control valve assembly	220	490
Swing motor assembly	390	860
Hydraulic oil tank assembly	250	560
Fuel tank assembly	240	530
Counterweight	7000	15450
Cab assembly	490	1080
Lower chassis assembly	10900	24030
Track frame weld assembly	3765	8300
Swing bearing	430	950
Travel motor assembly	400	880
Turning joint	54	120
Track recoil spring	205	450
Idler	252	560
Carrier roller	35	80
Track roller	54	119
Track-chain assembly (800 mm standard triple grouser shoe)	2340	5160
Front attachment assembly (10.2 m boom, 7.85 m arm, 0.51 m ³ SAE heaped bucket)	5920	13050
10.2 m boom assembly	2960	6530
7.85 m arm assembly	1340	2960
0.51 m ³ SAE heaped bucket	460	1010
Boom cylinder assembly	270	600
Arm cylinder assembly	360	790
Bucket cylinder assembly	96	212
Bucket control link assembly	110	240

3) R290LC-9 HIGH WALKER











Item	R290LC-9 HIGH WAKER	
	kg	lb
Upperstructure assembly	12610	27800
Main frame weld assembly	2670	5890
Engine assembly	556	1230
Main pump assembly	155	340
Main control valve assembly	220	490
Swing motor assembly	390	860
Hydraulic oil tank assembly	250	560
Fuel tank assembly	240	530
Counterweight	5200	11460
Cab assembly	490	1080
Lower chassis assembly	12800	28220
Track frame weld assembly	5825	12840
Swing bearing	430	950
Travel motor assembly	400	880
Turning joint	54	120
Track recoil spring	205	450
Idler	252	560
Carrier roller	35	80
Track roller	54	119
Track-chain assembly (600 mm standard triple grouser shoe)	1860	4110
Front attachment assembly (6.25 m boom, 3.05 m arm, 1.27 m ³ SAE heaped bucket)	5550	12240
6.25 m boom assembly	2285	5040
3.05 m arm assembly	1025	2260
1.27 m ³ SAE heaped bucket	1010	2230
Boom cylinder assembly	270	600
Arm cylinder assembly	360	790
Bucket cylinder assembly	220	485
Bucket control link assembly	110	240

5. LIFTING CAPACITIES

1) R290LC-9













(1) 6.25 m (20' 6") boom, 2.10 m (6' 11") arm equipped with 1.27 m³ (SAE heaped) bucket and 600 mm (24") triple grouser shoe and 5200 kg counterweight.

-  : Rating over-front
-  : Rating over-side or 360 degree















Load point height		Load radius								At max. reach		
		3.0 m (10 ft)		4.5 m (15 ft)		6.0 m (20 ft)		7.5 m (25 ft)		Capacity		Reach
												m (ft)
7.5 m (25 ft)	kg lb					*5760 *12700	*5760 *12700			*5290 *11660	4580 10100	8.01 (26.3)
6.0 m (20 ft)	kg lb					*6090 *13430	*6090 *13430	*5900 *13010	4950 10910	*5380 *11860	3670 8090	8.90 (29.2)
4.5 m (15 ft)	kg lb			*8940 *19710	*8940 *19710	*7040 *15520	*7040 *15520	*6210 *13690	4820 10630	5270 11620	3200 7050	9.42 (30.9)
3.0 m (10 ft)	kg lb			*11660 *25710	10180 22440	*8270 *18230	6600 14550	*6800 *14990	4610 10160	4990 11000	2990 6590	9.64 (31.6)
1.5 m (5 ft)	kg lb			*13520 *29810	9490 20920	*9370 *20660	6210 13690	7330 16160	4400 9700	4980 10980	2970 6550	9.58 (31.4)
Ground Line	kg lb			*14060 *31000	9290 20480	*10020 *22090	5980 13180	7180 15830	4270 9410	5260 11600	3140 6920	9.23 (30.3)
-1.5 m (-5 ft)	kg lb	*13470 *29700	*13470 *29700	*13770 *30360	9310 20530	*10110 *22290	5920 13050	7150 15760	4240 9350	5970 13160	3590 7910	8.57 (28.1)
-3.0 m (-10 ft)	kg lb	*17570 *38740	*17570 *38740	*12710 *28020	9480 20900	*9440 *20810	6020 13270			*6180 *13620	4610 10160	7.47 (24.5)
-4.5 m (-15 ft)	kg lb	*14150 *31200	*14150 *31200	*10330 *22770	9880 21780							

- Note
1. Lifting capacity are based on SAE J1097 and ISO 10567.
 2. Lifting capacity of the ROBEX series does not exceed 75% of tipping load with the machine on firm, level ground or 87% of full hydraulic capacity.
 3. The load point is a hook located on the back of the bucket.
 4. *indicates load limited by hydraulic capacity.















(2) 6.25 m (20' 6") boom, 2.50 m (8' 2") arm equipped with 1.27 m³ (SAE heaped) bucket and 600 mm (24") triple grouser shoe and 5200 kg counterweight.

Load point height		Load radius										At max. reach			
		1.5 m (5 ft)		3.0 m (10 ft)		4.5 m (15 ft)		6.0 m (20 ft)		7.5 m (25 ft)		Capacity		Reach	
														m (ft)	
7.5 m (25 ft)	kg lb												*4880 *10760	4330 9550	8.34 (27.4)
6.0 m (20 ft)	kg lb									*5470 *12060	5060 11160		*5020 *11070	3510 7740	9.19 (30.2)
4.5 m (15 ft)	kg lb					*8180 18030	*8180 *18030	*6610 *14570	*6610 *14570	*5880 *12960	4900 10800		5070 11180	3080 6790	9.69 (31.8)
3.0 m (10 ft)	kg lb					*10910 *24050	10440 23020	*7890 *17390	6700 14770	*6530 *14400	4660 10270		4790 10560	2870 6330	9.90 (32.5)
1.5 m (5 ft)	kg lb					*13040 *28750	9630 21230	*9080 *20020	6270 13820	*7190 *15850	4430 9770		4770 10520	2840 6260	9.84 (32.3)
Ground Line	kg lb					*13950 *30750	9310 20530	9870 *21760	6000 13230	7180 15830	4270 9410		5000 11020	2980 6570	9.51 (31.2)
-1.5 m (-5 ft)	kg lb			*14370 *31680	*14370 *31680	*13930 *30710	9260 20410	*10120 *22310	5900 13010	7110 15670	4210 9280		5610 12370	3360 7410	8.87 (29.1)
-3.0 m (-10 ft)	kg lb	*16270 *35870	*16270 *35870	*18700 *41230	*18700 *41230	*13110 *28900	9390 20700	*9690 *21360	5950 13120				*6310 *13910	4210 9280	7.82 (25.7)
-4.5 m (-15 ft)	kg lb			*15620 *34440	*15620 *34440	*11170 *24630	9720 21430								

(3) 6.25 m (20' 6") boom, 3.05 m (10' 0") arm equipped with 1.27 m³ (SAE heaped) bucket and 600 mm (24") triple grouser shoe and 5200 kg counterweight.

Load point height		Load radius										At max. reach				
		1.5 m (5 ft)		3.0 m (10 ft)		4.5 m (15 ft)		6.0 m (20 ft)		7.5 m (25 ft)		9.0 m (30 ft)		Capacity		Reach
																m (ft)
7.5 m (25 ft)	kg lb													*4780 *10540	3850 8490	8.94 (29.3)
6.0 m (20 ft)	kg lb									*5270 *11620	5190 11440			*4940 *10890	3170 6990	9.74 (32.0)
4.5 m (15 ft)	kg lb							*6380 *14070	*6380 *14070	*5780 *12740	4980 10980			4660 10270	2790 6150	10.20 (33.5)
3.0 m (10 ft)	kg lb			*10490 *23130	*10490 *23130	*10510 *23170	*10510 *23170	*7800 *17200	6830 15060	*6530 *14400	4710 10380	*4420 *9740	3380 7450	4410 9720	2600 5730	10.40 (34.1)
1.5 m (5 ft)	kg lb					*13100 *28880	9840 21690	*9190 *20260	6340 13980	*7320 *16140	4440 9790	*5230 *11530	3240 7140	4380 9660	2560 5640	10.35 (34.0)
Ground Line	kg lb			*10140 *22350	*10140 *22350	*14530 *32030	9340 20590	*10220 *22530	6000 13230	7190 15850	4240 9350	*4600 *10140	3140 6920	4560 10050	2660 5860	10.04 (32.9)
-1.5 m (-5 ft)	kg lb	*10990 *24230	*10990 *24230	*14250 *31420	*14250 *31420	*14890 *32830	9180 20240	10140 22350	5830 12850	7070 15590	4130 9110			5050 11130	2960 6530	9.44 (31.0)
-3.0 m (-10 ft)	kg lb	*14880 *32800	*14880 *32800	*19250 *42440	*19250 *42440	*14380 *31700	9240 20370	10130 22330	5830 12850	7090 15630	4150 9150			6060 13360	3610 7960	8.48 (27.8)
-4.5 m (-15 ft)	kg lb	*19470 *42920	*19470 *42920	*18400 *40570	*18400 *40570	*12820 *28260	9500 20940	*9370 *20660	6010 13250					*6400 *14110	5150 11350	6.97 (22.9)

(4) 6.25 m (20' 6") boom, 3.75 m (12' 4") arm equipped with 1.27 m³ (SAE heaped) bucket and 600 mm (24") triple grouser shoe and 5200 kg counterweight.











Load point height		Load radius												At max. reach			
		1.5 m (5 ft)		3.0 m (10 ft)		4.5 m (15 ft)		6.0 m (20 ft)		7.5 m (25 ft)		9.0 m (30 ft)		Capacity		Reach	
																	m (ft)
7.5 m (25 ft)	kg lb														*3930 *8660	3310 7300	9.67 (31.7)
6.0 m (20 ft)	kg lb								*4160 *9170	*4160 *9170	*2370 *5220	*2370 *5220	*4090 *9020	2770 6110	10.40 (34.1)		
4.5 m (15 ft)	kg lb								*4710 *10380	*4710 *10380	*3720 *8200	3550 7830	4160 9170	2460 5420	10.83 (35.5)		
3.0 m (10 ft)	kg lb			*13490 *29740	*13490 *29740	*8320 *18340	*8320 *18340	*6410 *14130	*6410 *14130	*5470 *12060	4760 10490	*4740 *10450	3400 7500	3950 8710	2300 5070	11.02 (36.2)	
1.5 m (5 ft)	kg lb			*9980 *22000	*9980 *22000	*11050 *24360	10090 22240	*7850 *17310	6420 14150	*6300 *13890	4470 9850	*5440 *11990	3240 7140	3920 8640	2260 4980	10.97 (36.0)	
Ground Line	kg lb	*6470 *14260	*6470 *14260	*10300 *22710	*10300 *22710	*12890 *28420	9400 20720	*9020 *19890	6010 13250	*7030 *15500	4220 9300	5300 11680	3100 6830	4050 8930	2330 5140	10.68 (35.0)	
-1.5 m (-5 ft)	kg lb	*9310 *20530	*9310 *20530	*12760 *28130	*12760 *28130	*13720 *30250	9090 20040	*9730 *21450	5770 12720	6970 15370	4070 8970	5210 11490	3020 6660	4410 9720	2560 5640	10.12 (33.2)	
-3.0 m (-10 ft)	kg lb	*12290 *27090	*12290 *27090	*16240 *35800	*16240 *35800	*13690 *30180	9040 19930	*9880 *21780	5700 12570	6920 15260	4020 8360			5140 11330	3030 6680	9.25 (30.3)	
-4.5 m (-15 ft)	kg lb	*15740 *34700	*15740 *34700	*18940 *41760	18940 41760	*12770 *28150	9190 20260	*9310 *20530	5780 12740					*5780 *12740	4030 8880	7.92 (26.0)	

2) R290NLC-9

(1) 6.25 m (20' 6") boom, 2.10 m (6' 11") arm equipped with 1.27 m³ (SAE heaped) bucket and 600 mm (24") triple grouser shoe and 5200 kg counterweight.

•  : Rating over-front

•  : Rating over-side or 360 degree

Load point height		Load radius								At max. reach		
		3.0 m (10 ft)		4.5 m (15 ft)		6.0 m (20 ft)		7.5 m (25 ft)		Capacity		Reach
												m (ft)
7.5 m (25 ft)	kg lb					*5760 *12700	*5760 *12700			*5290 *11660	4140 9130	8.01 (26.3)
6.0 m (20 ft)	kg lb					*6090 *13430	*6090 *13430	*5900 *13010	4470 9850	*5380 *11860	3300 7280	8.90 (29.2)
4.5 m (15 ft)	kg lb			*8940 *19710	*8940 *19710	*7040 *15520	6390 14090	*6210 *13690	4350 9590	5250 11570	2860 6310	9.42 (30.9)
3.0 m (10 ft)	kg lb			*11660 *25710	9090 20040	*8270 *18230	5930 13070	*6800 *14990	4140 9130	4960 10930	2660 5860	9.64 (31.6)
1.5 m (5 ft)	kg lb			*13520 *29810	8420 18560	*9370 *20660	5550 12240	7290 16070	3940 8690	4950 10910	2640 5820	9.58 (31.4)
Ground Line	kg lb			*14060 *31000	8220 18120	*10020 *22090	5330 11750	7140 15740	3800 8380	5230 11530	2790 6150	9.23 (30.3)
-1.5 m (-5 ft)	kg lb	*13470 *29700	*13470 *29700	*13770 *30360	8240 18170	*10110 *22290	5270 11620	7110 15670	3780 8330	5930 13070	3210 7080	8.57 (28.1)
-3.0 m (-10 ft)	kg lb	*17570 *38740	*17290 *38120	*12710 *28020	8410 18540	*9440 *20810	5370 11840			*6180 *13620	4130 9110	7.47 (24.5)
-4.5 m (-15 ft)	kg lb	*14150 *31200	*14150 *31200	*10330 *22770	8800 19400							

- Note
1. Lifting capacity are based on SAE J1097 and ISO 10567.
 2. Lifting capacity of the ROBEX series does not exceed 75% of tipping load with the machine on firm, level ground or 87% of full hydraulic capacity.
 3. The load point is a hook located on the back of the bucket.
 4. * indicates load limited by hydraulic capacity.















(2) 6.25 m (20' 6") boom, 2.50 m (8' 2") arm equipped with 1.27 m³ (SAE heaped) bucket and 600 mm (24") triple grouser shoe and 5200 kg counterweight.

Load point height		Load radius										At max. reach				
		1.5 m (5 ft)		3.0 m (10 ft)		4.5 m (15 ft)		6.0 m (20 ft)		7.5 m (25 ft)		Capacity		Reach		
														m (ft)		
7.5 m (25 ft)	kg lb													*4880 *10760	3920 8640	8.34 (27.4)
6.0 m (20 ft)	kg lb									*5470 *12060	4580 10100			*5020 *11070	3160 6970	9.19 (30.2)
4.5 m (15 ft)	kg lb					*8180 18030	*8180 *18030	*6610 *14570	6500 14330	*5880 *12960	4420 9740			5040 11110	2750 6060	9.69 (31.8)
3.0 m (10 ft)	kg lb					*10910 *24050	9330 20570	*7890 *17390	6030 13290	*6530 *14400	4190 9240			4760 10490	2550 5620	9.90 (32.5)
1.5 m (5 ft)	kg lb					*13040 *28750	8550 18850	*9080 *20020	5610 12370	*7190 *15850	3970 8750			4740 10450	2520 5560	9.84 (32.3)
Ground Line	kg lb					*13950 *30750	8240 18170	*9870 *21760	5350 11790	7140 15740	3810 8400			4970 10960	2640 5820	9.51 (31.2)
-1.5 m (-5 ft)	kg lb			*14370 *31680	*14370 *31680	*13930 *30710	8190 18060	10090 22240	5250 11570	7070 15590	3740 8250			5580 12300	2990 6590	8.87 (29.1)
-3.0 m (-10 ft)	kg lb	*16270 *35870	*16270 *35870	*18700 *41230	17040 37570	*13110 *28900	8310 18320	*9690 *21360	5300 11680					*6310 *13910	3770 8310	7.82 (25.7)
-4.5 m (-15 ft)	kg lb			*15620 *34440	*15620 *34440	*11170 *24630	8630 19030									

(3) 6.25 m (20' 6") boom, 3.05 m (10' 0") arm equipped with 1.27 m³ (SAE heaped) bucket and 600 mm (24") triple grouser shoe and 5200 kg counterweight.

Load point height		Load radius												At max. reach			
		1.5 m (5 ft)		3.0 m (10 ft)		4.5 m (15 ft)		6.0 m (20 ft)		7.5 m (25 ft)		9.0 m (30 ft)		Capacity		Reach	
																m (ft)	
7.5 m (25 ft)	kg lb														*4460 *9830	3460 7630	8.94 (29.3)
6.0 m (20 ft)	kg lb									*4910 *10820	4670 10300			*4600 *10140	2830 6240	9.74 (32.0)	
4.5 m (15 ft)	kg lb							*5960 *13140	*5960 *13140	*5390 *11880	4480 9880			4610 10160	2480 5470	10.20 (33.5)	
3.0 m (10 ft)	kg lb			*9910 *21850	*9910 *21850	*9820 *21650	9600 21160	*7280 *16050	6110 13470	*6090 *13430	4220 9300	*4140 *9130	3010 6640	4370 9630	2310 5090	10.40 (34.1)	
1.5 m (5 ft)	kg lb					*12250 *27010	8690 19160	*8590 *18940	5650 12460	*6830 *15060	3960 8730	*4900 *10800	2880 6320	4340 9570	2270 5000	10.35 (34.0)	
Ground Line	kg lb			*9590 *21140	*9590 *21140	*13580 *29940	8220 18120	*9550 *21050	5320 11730	7110 15670	3770 8310	*4310 *9500	2780 6130	4520 9960	2360 5200	10.04 (32.9)	
-1.5 m (-5 ft)	kg lb	*10390 *22910	*10390 *22910	*13470 *29700	*13470 *29700	*13920 *30690	8080 17810	*10000 *22050	5170 11400	6990 15410	3660 8070			4990 11000	2630 5800	9.44 (31.0)	
-3.0 m (-10 ft)	kg lb	*14060 *31000	*14060 *31000	*18180 *40080	16660 36730	*13440 *29630	8130 17920	*9830 *21670	5160 11380	7010 15450	3680 8110			*5980 *13180	3220 7100	8.48 (27.8)	
-4.5 m (-15 ft)	kg lb	*18380 *40520	*18380 *40520	*17190 *37900	17140 37790	*11970 *26390	8370 18450	*8750 *19290	5330 11750					*5960 *13140	4600 10140	6.97 (22.9)	

















(4) 6.25 m (20' 6") boom, 3.75 m (12' 4") arm equipped with 1.27 m³ (SAE heaped) bucket and 600 mm (24") triple grouser shoe and 5200 kg counterweight.

Load point height		Load radius												At max. reach		
		1.5 m (5 ft)		3.0 m (10 ft)		4.5 m (15 ft)		6.0 m (20 ft)		7.5 m (25 ft)		9.0 m (30 ft)		Capacity		Reach
																m (ft)
7.5 m (25 ft)	kg lb													*3930 *8660	2980 6570	9.67 (31.7)
6.0 m (20 ft)	kg lb								*4160 *9170	*4160 *9170	*2370 *5220	*2370 *5220	*4090 *9020	2470 5450	10.40 (34.1)	
4.5 m (15 ft)	kg lb								*4710 *10380	4560 10050	*3720 *8200	3180 7010	4140 9130	2180 4810	10.83 (35.5)	
3.0 m (10 ft)	kg lb			*13490 *29740	*13490 *29740	*8320 *18340	*8320 *18340	*6410 *14130	6280 13850	*5470 *12060	4280 9440	*4740 *10450	3030 6680	3930 8660	2020 4450	11.02 (36.2)
1.5 m (5 ft)	kg lb			*9980 *22000	*9980 *22000	*11050 *24360	8990 19820	*7850 *17310	5760 12700	*6300 *13890	3990 8800	5420 11950	2870 6330	3890 8580	1980 4370	10.97 (36.0)
Ground Line	kg lb	*6470 *14260	*6470 *14260	*10300 *22710	*10300 *22710	*12890 *28420	8320 18340	*9020 *19890	5360 11820	*7030 *15500	3750 8270	5270 11620	2740 6040	4030 8880	2040 4500	10.68 (35.0)
-1.5 m (-5 ft)	kg lb	*9310 *20530	*9310 *20530	*12760 *28130	*12760 *28130	*13720 *30250	8020 17680	*9730 *21450	5120 11290	6930 15280	3600 7940	5180 11420	2660 5860	4380 9660	2250 4960	10.12 (33.2)
-3.0 m (-10 ft)	kg lb	*12290 *27090	*12290 *27090	*16240 *35800	*16240 *35800	*13690 *30180	7970 17570	*9880 *21780	5050 11130	6880 15170	3550 7830			5110 11270	2680 5910	9.25 (30.3)
-4.5 m (-15 ft)	kg lb	*15740 *34700	*15740 *34700	*18940 *41760	16670 36750	*12770 *28150	8120 17900	*9310 *20530	5120 11290					*5780 *12740	3590 7910	7.92 (26.0)

3) R290LC-9 LONG REACH

(1) 10.2 m (33' 6") boom, 7.85 m (25' 9") arm equipped with 0.52 m³ (SAE heaped) bucket and 800 mm (32") triple grouser shoe and 7000 kg counterweight.

-  : Rating over-front
-  : Rating over-side or 360 degree











Load point height		Load radius														At max. reach			
		6.0 m (20.0 ft)		7.5 m (25.0 ft)		9.0 m (30.0 ft)		10.5 m (35.0 ft)		12.0 m (40.0 ft)		13.5 m (45.0 ft)		15.0 m (50.0 ft)		Capacity	Reach		
																		m (ft)	
13.5 m 45.0 ft	kg lb																*1820 *4010	*1820 *4010	14.13 (46.4)
12.0 m 40.0 ft	kg lb																*1840 *4060	*1840 *4060	15.27 (50.1)
10.5 m 35.0 ft	kg lb													*1100 *2430	*1100 *2430	*1870 *4120	1830 4030	16.18 (53.1)	
9.0 m 30.0 ft	kg lb													*1560 *3440	*1560 *3440	*1920 *4230	1600 3530	16.89 (55.4)	
7.5 m 25.0 ft	kg lb											*1940 *4280	*1940 *4280	*1870 *4120	*1870 *4120	*1970 *4340	1440 3170	17.44 (57.2)	
6.0 m 20.0 ft	kg lb											*2090 *4610	*2090 *4610	*2060 *4540	2020 4450	*2030 *4480	1310 2890	17.83 (58.5)	
4.5 m 15.0 ft	kg lb								*2390 *5270	*2390 *5270	*2270 *5000	*2270 *5000	*2190 *4830	1930 4250	*2090 *4610	1220 2690	18.08 (59.3)		
3.0 m 10.0 ft	kg lb					*3320 *7320	*3320 *7320	*2940 *6480	*2940 *6480	*2670 *5890	*2670 *5890	*2480 *5470	2290 5050	*2340 *5160	1830 4030	2120 4670	1150 2540	18.20 (59.7)	
1.5 m 5.0 ft	kg lb	*6230 *13730	*6230 *13730	*4760 *10490	*4760 *10490	*3900 *8600	*3900 *8600	*3340 *7360	*3340 *7360	*2970 *6550	2670 5890	*2700 *5950	2140 4720	*2510 *5530	1730 3810	2080 4590	1110 2450	18.19 (59.7)	
Ground /line	kg lb	*7390 *16290	6790 14970	*5530 *12190	5040 11110	*4440 *9790	3900 8600	*3740 *8250	3090 6810	*3260 *7190	2480 5470	*2920 *6440	2010 4430	*2670 *5890	1630 3590	2070 4560	1100 2430	18.04 (59.2)	
-1.5 m -5.0 ft	kg lb	*8230 *18140	6220 13710	*6170 *13600	4620 10190	*4910 *10820	3590 7910	*4090 *9020	2870 6330	*3530 *7780	2320 5110	*3120 *6880	1890 4170	2770 6110	1540 3400	2100 4630	1110 2450	17.76 (58.3)	
-3.0 m -10.0 ft	kg lb	*8770 *19330	5900 13010	*6630 *14620	4340 9570	*5290 *11660	3370 7430	*4390 *9680	2690 5930	*3760 *8290	2190 4830	3190 7030	1790 3950	2700 5950	1480 3260	2170 4780	1140 2510	17.33 (56.9)	
-4.5 m -15.0 ft	kg lb	*9070 *20000	5750 12680	*6930 *15280	4180 9220	*5550 *12240	3230 7120	4530 9990	2580 5690	3730 8220	2100 4630	3120 6880	1730 3810	2660 5860	1440 3170	2280 5030	1220 2690	16.75 (55.0)	
-6.0 m -20.0 ft	kg lb	*9150 *20170	5710 12590	*7080 *15610	4120 9080	5580 12300	3160 6970	4460 9830	2510 5530	3670 8090	2050 4520	3090 6810	1700 3750	2650 5840	1430 3150	2470 5450	1330 2930	15.99 (52.5)	
-7.5 m -25.0 ft	kg lb	*9030 *19910	5770 12720	*7060 *15560	4130 9110	5570 12280	3150 6940	4450 9810	2510 5530	3670 8090	2050 4520	3110 6860	1710 3770			2740 6040	1520 3350	15.04 (49.3)	
-9.0 m -30.0 ft	kg lb	*8690 *19160	5920 13050	*6860 *15120	4220 9300	*5590 *12320	3210 7080	4500 9920	2550 5620	3730 8220	2100 4630					*3130 *6900	1800 3970	13.83 (45.4)	
-10.5 m -35.0 ft	kg lb	*8080 *17810	6150 13560	*6430 *14180	4380 9660	*5250 *11570	3340 7360	*4340 *9570	2670 5890	*3570 *7870	2230 4920					*3290 *7250	2270 5000	12.31 (40.4)	
-12.0 m -40.0 ft	kg lb	*7090 *15630	6490 14310	*5670 *12500	4630 10210	*4580 *10100	3560 7850												
-13.5 m -45.0 ft	kg lb	*5480 *12080	*5480 *12080	*4290 *9460	*4290 *9460														

- Note
1. Lifting capacity are based on SAE J1097 and ISO 10567.
 2. Lifting capacity of the ROBEX series does not exceed 75% of tipping load with the machine on firm, level ground or 87% of full hydraulic capacity.
 3. The load point is a hook located on the back of the bucket.
 4. * indicates load limited by hydraulic capacity.

4) R290LC-9 HIGH WALKER













(1) 6.25 m (20' 6") boom, 2.10 m (6' 11") arm equipped with 1.27 m³ (SAE heaped) bucket and 600 mm (24") triple grouser shoe and 5200 kg counterweight.

-  : Rating over-front
-  : Rating over-side or 360 degree















Load point height	Load radius								At max. reach			
	3.0 m (10 ft)		4.5 m (15 ft)		6.0 m (20 ft)		7.5 m (25 ft)		Capacity		Reach	
											m (ft)	
7.5 m (25 ft)	kg					*5750	*5750			*5300	5190	8.21
	lb					*12680	*12680			*11680	11440	(26.9)
6.0 m (20 ft)	kg					*6220	*6220	*5920	5880	*5400	4290	9.02
	lb					*13710	*13710	*13050	12960	*11900	9460	(29.6)
4.5 m (15 ft)	kg			*9430	*9430	*7260	*7260	*6310	5720	*5560	3840	9.48
	lb			*20790	*20790	*16010	*16010	*13910	12610	*12260	8470	(31.1)
3.0 m (10 ft)	kg			*12110	12050	*8490	7800	*6910	5500	5540	3640	9.65
	lb			*26700	26570	*18720	17200	*15230	12130	12210	8020	(31.7)
1.5 m (5 ft)	kg			*13700	11450	*9530	7430	*7490	5300	5590	3660	9.54
	lb			*30200	25240	*21010	16380	*16510	11680	12320	8070	(31.3)
Ground Line	kg			*14060	11290	*10080	7230	*7830	5180	5970	3910	9.14
	lb			*31000	24890	*22220	15940	*17260	11420	13160	8620	(30.0)
-1.5 m (-5 ft)	kg	*14990	*14990	*13640	11340	*10050	7200	*7690	5180	*6270	4520	8.40
	lb	*33050	*33050	*30070	25000	*22160	15870	*16950	11420	*13820	9960	(27.6)
-3.0 m (-10 ft)	kg	*17110	*17110	*12400	11560	*9200	7340			*6100	5900	7.21
	lb	*37720	*37720	*27340	25490	*20280	16180			*13450	13010	(23.7)
-4.5 m (-15 ft)	kg	*13230	*13230	*9610	*9610							
	lb	*29170	*29170	*21190	*21190							

- Note
1. Lifting capacity are based on SAE J1097 and ISO 10567.
 2. Lifting capacity of the ROBEX series does not exceed 75% of tipping load with the machine on firm, level ground or 87% of full hydraulic capacity.
 3. The load point is a hook located on the back of the bucket.
 4. *indicates load limited by hydraulic capacity.

(2) 6.25 m (20' 6") boom, 2.50 m (8' 2") arm equipped with 1.27 m³ (SAE heaped) bucket and 600 mm (24") triple grouser shoe and 5200 kg counterweight.

Load point height		Load radius										At max. reach				
		1.5 m (5 ft)		3.0 m (10 ft)		4.5 m (15 ft)		6.0 m (20 ft)		7.5 m (25 ft)		Capacity		Reach		
														m (ft)		
7.5 m (25 ft)	kg lb													*4910 *10820	*4910 *10820	8.52 (28.0)
6.0 m (20 ft)	kg lb							*5770 *12720	*5770 *12720	*5520 *12170	*5520 *12170	*5060 *11160	4120 9080	9.30 (30.5)		
4.5 m (15 ft)	kg lb					*8660 *19090	*8660 *19090	*6830 *15060	*6830 *15060	*5990 *13210	5790 12760	*5240 *11550	3690 8140	9.75 (32.0)		
3.0 m (10 ft)	kg lb					*11380 *25090	*11380 *25090	*8130 *17920	7900 17420	*6650 *14660	5550 12240	5330 11750	3500 7720	9.91 (32.5)		
1.5 m (5 ft)	kg lb					*13300 *29320	11560 25490	*9260 *20410	7490 16510	*7300 *16090	5330 11750	5350 11790	3500 7720	9.80 (32.2)		
Ground Line	kg lb			*9530 *21010	*9530 *21010	*14010 *30890	11290 24890	*9960 *21960	7240 15960	*7730 *17040	5180 11420	5680 12520	3710 8180	9.42 (30.9)		
-1.5 m (-5 ft)	kg lb	*12300 *27120	*12300 *27120	*15460 *34080	*15460 *34080	*13840 *30510	11280 24870	*10100 *22270	7170 15810	*7780 *17150	5140 11330	*6210 *13690	4230 9330	8.71 (28.6)		
-3.0 m (-10 ft)	kg lb	*17240 *38010	*17240 *38010	*18270 *40280	*18270 *40280	*12870 *28370	11450 25240	*9510 *20970	7250 15980			*6300 *13890	5380 11860	7.58 (24.9)		
-4.5 m (-15 ft)	kg lb			*14820 *32670	*14820 *32670	*10610 *23390	*10610 *23390									

(3) 6.25 m (20' 6") boom, 3.05 m (10' 0") arm equipped with 1.27 m³ (SAE heaped) bucket and 600 mm (24") triple grouser shoe and 5200 kg counterweight.



Load point height		Load radius										At max. reach				
		1.5 m (5 ft)		3.0 m (10 ft)		4.5 m (15 ft)		6.0 m (20 ft)		7.5 m (25 ft)		9.0 m (30 ft)		Capacity		Reach
																m (ft)
7.5 m (25 ft)	kg lb									*3300 *7280	*3300 *7280			*4480 *9880	4400 9700	9.12 (29.9)
6.0 m (20 ft)	kg lb									*4980 *10980	*4980 *10980			*4630 *10210	3730 8220	9.84 (32.3)
4.5 m (15 ft)	kg lb									*6180 *13620	*6180 *13620	*5510 *12150	*5510 *12150	*4820 *10630	3370 7430	10.26 (33.7)
3.0 m (10 ft)	kg lb					*10320 *22750	*10320 *22750	*7530 *16600	*7530 *16600	*6230 *13730	5580 12300	*2910 *6420	*2910 *6420	4900 10800	3200 7050	10.41 (34.2)
1.5 m (5 ft)	kg lb			*6850 *15100	*6850 *15100	*12580 *27730	11680 25750	*8790 *19380	7520 16580	*6950 *15320	5320 11730	*4340 *9570	4080 8990	4910 10820	3190 7030	10.31 (33.8)
Ground Line	kg lb			*10250 *22600	*10250 *22600	*13710 *30230	11260 24820	*9670 *21320	7210 15900	*7500 *16530	5140 11330	*4920 *10850	3950 8710	5160 11380	3350 7390	9.95 (32.6)
-1.5 m (-5 ft)	kg lb	*11020 *24290	*11020 *24290	*14240 *31390	*14240 *31390	*13900 *30640	11150 24580	*10020 *22090	7080 15610	*7720 *17020	5050 11130			5760 12700	3760 8290	9.29 (30.5)
-3.0 m (-10 ft)	kg lb	*14780 *32580	*14780 *32580	*19180 *42280	*19180 *42280	*13260 *29230	11240 24780	*9720 *21430	7100 15650	*7360 *16230	5100 11240			*6010 *13250	4610 10160	8.25 (27.1)
-4.5 m (-15 ft)	kg lb	*19280 *42510	*19280 *42510	*16520 *36420	*16520 *36420	*11550 *25460	11540 25440	*8370 *18450	7320 16140							

(4) 6.25 m (20' 6") boom, 3.75 m (12' 4") arm equipped with 1.27 m³ (SAE heaped) bucket and 600 mm (24") triple grouser shoe and 5200 kg counterweight.

Load point height		Load radius												At max. reach			
		1.5 m (5 ft)		3.0 m (10 ft)		4.5 m (15 ft)		6.0 m (20 ft)		7.5 m (25 ft)		9.0 m (30 ft)		Capacity		Reach	
																m (ft)	
7.5 m (25 ft)	kg lb														*3960 *8730	3850 8490	9.83 (32.3)
6.0 m (20 ft)	kg lb								*4240 *9350	*4240 *9350	*2680 *5910	*2680 *5910	*4120 *9080	3310 7300	10.50 (34.4)		
4.5 m (15 ft)	kg lb								*4830 *10650	4830 10650	*3910 *8620	*3910 *8620	*4310 *9500	3000 6610	10.89 (35.7)		
3.0 m (10 ft)	kg lb			*14870 *32780	*14870 *32780	*8850 *19510	*8850 *19510	*6680 *14730	*6680 *14730	*5620 *12390	*5620 *12390	*4930 *10870	4100 9040	4420 9740	2850 6280	11.03 (36.2)	
1.5 m (5 ft)	kg lb			*9690 *21360	*9690 *21360	*11460 *25260	*11460 *25260	*8090 *17840	7620 16800	*6450 *14220	5350 11790	*5530 *12190	3940 8690	4420 9740	2830 6240	10.93 (35.9)	
Ground Line	kg lb	*6990 *15410	*6990 *15410	*10660 *23500	*10660 *23500	*13120 *28920	11340 25000	*9190 *20260	7230 15940	*7130 *15720	5120 11290	5910 13030	3810 8400	4610 10160	2950 6500	10.60 (34.8)	
-1.5 m (-5 ft)	kg lb	*9830 *21670	*9830 *21670	*13320 *29370	*13320 *29370	*13780 *30380	11080 24430	*9800 *21610	7020 15480	*7550 *16640	4980 10980	*4790 *10560	3740 8250	5060 11160	3260 7190	9.99 (32.8)	
-3.0 m (-10 ft)	kg lb	*12870 *28370	*12870 *28370	*16990 *37460	*16990 *37460	*13590 *29960	11060 24380	*9840 *21690	6970 15370	*7530 *16600	4950 10910			*5610 *12370	3880 8550	9.04 (29.7)	
-4.5 m (-15 ft)	kg lb	*16450 *36270	*16450 *36270	*18430 *40630	*18430 *40630	*12480 *27510	11250 24800	*9100 *20060	7080 15610					*5790 *12760	5250 11570	7.61 (25.0)	

6. BUCKET SELECTION GUIDE

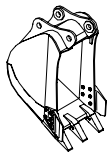
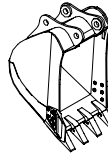
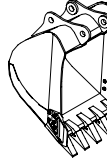
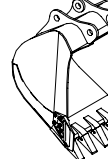
1) GENERAL BUCKET

					
0.79 m ³ SAE heaped bucket	1.03 m ³ SAE heaped bucket	※1.27 m ³ SAE heaped bucket	1.50 m ³ SAE heaped bucket	1.73 m ³ SAE heaped bucket	1.85 m ³ SAE heaped bucket

Capacity		Width		Weight	Recommendation			
					6.25 m (20' 6") boom			
SAE heaped	CECE heaped	Without side cutter	With side cutter		2.1 m arm (6' 11")	2.5 m arm (8' 2")	3.05 m arm (10' 0")	3.75 m arm (12' 4")
0.79 m ³ (1.03 yd ³)	0.70 m ³ (0.92 yd ³)	890 mm (35.0")	1010 mm (39.8")	790 kg (1740 lb)				
1.03 m ³ (1.35 yd ³)	0.90 m ³ (1.18 yd ³)	1090 mm (42.9")	1210 mm (47.6")	890 kg (1960 lb)				
※1.27 m ³ (1.66 yd ³)	1.10 m ³ (1.44 yd ³)	1290 mm (50.8")	1410 mm (55.5")	1010 kg (2230 lb)				
1.50 m ³ (1.96 yd ³)	1.30 m ³ (1.70 yd ³)	1490 mm (58.7")	1610 mm (63.4")	1080 kg (2380 lb)				
1.73 m ³ (2.26 yd ³)	1.50 m ³ (1.96 yd ³)	1700 mm (66.9")	1820 mm (71.7")	1170 kg (2580 lb)				
1.85 m ³ (2.42 yd ³)	1.60 m ³ (2.09 yd ³)	1800 mm (70.9")	1920 mm (75.6")	1230 kg (2710 lb)				

※ : Standard bucket

 Applicable for materials with density of 2000 kg/m³ (3370 lbf/yd³) or less

 Applicable for materials with density of 1600 kg/m³ (2700 lbf/yd³) or less

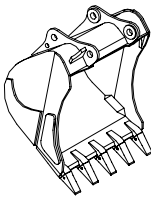
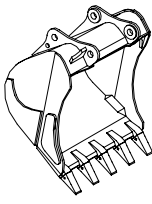
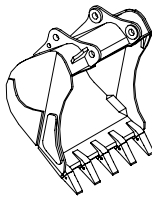
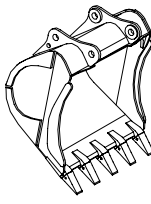

 Applicable for materials with density of 1100 kg/m³ (1850 lbf/yd³) or less

2) ROCK AND HEAVY DUTY BUCKET

			
◆ 1.07 m³ SAE ◆ 1.15 m³ SAE heaped bucket	◆ 1.27 m³ SAE heaped bucket	◆ 1.46 m³ SAE heaped bucket	◎ 1.16 m³ SAE ◎ 1.49 m³ SAE heaped bucket

Capacity		Width		Weight	Recommendation			
SAE heaped	CECE heaped	Without side cutter	With side cutter		6.25 m (20' 6") boom			
					2.1 m arm (6' 11")	2.5 m arm (8' 2")	3.05 m arm (10' 0")	3.75 m arm (12' 4")
◆ 1.07 m³ (1.40 yd³)	0.95 m³ (1.24 yd³)	1150 mm (45.3")	-	1120 kg (2470 lb)				
◆ 1.15 m³ (1.50 yd³)	1.00 m³ (1.31 yd³)	1210 mm (47.6")	-	1160 kg (2560 lb)				
◆ 1.27 m³ (1.66 yd³)	1.10 m³ (1.44 yd³)	1310 mm (51.6")	-	1240 kg (2730 lb)				
◆ 1.46 m³ (1.91 yd³)	1.28 m³ (1.67 yd³)	1460 mm (57.5")	-	1320 kg (2910 lb)				
◎ 1.16 m³ (1.52 yd³)	1.00 m³ (1.31 yd³)	1340 mm (52.8")	-	1280 kg (2820 lb)				
◎ 1.49 m (1.95 yd³)	1.28 m (1.67 yd³)	1620 mm (63.8")	-	1440 kg (3170 lb)				

※ : Standard bucket

-  Applicable for materials with density of 2000 kgf/m³ (3370 lbf/yd³) or less
-  Applicable for materials with density of 1600 kgf/m³ (2700 lbf/yd³) or less
-  Applicable for materials with density of 1100 kgf/m³ (1850 lbf/yd³) or less

7. UNDERCARRIAGE

1) TRACKS

X-leg type center frame is integrally welded with reinforced box-section track frames. The design includes dry tracks, lubricated rollers, idlers, sprockets, hydraulic track adjusters with shock absorbing springs and assembled track-type tractor shoes with triple grousers.

2) TYPES OF SHOES

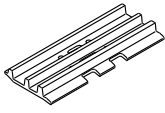
Model	Shapes		Triple grouser			
						
R290LC-9	Shoe width	mm (in)	600 (24)	700 (28)	800 (32)	900 (36)
	Operating weight	kg (lb)	29300 (64600)	29880 (65870)	30460 (67150)	31040 (68430)
	Ground pressure	kgf/cm ² (psi)	0.57 (8.11)	0.49 (6.97)	0.44 (6.26)	0.40 (5.69)
	Overall width	mm (ft-in)	3200 (10' 6")	3300 (10' 10")	3400 (11' 1")	3500 (11' 5")
R290NLC-9	Shoe width	mm (in)	600 (24)	-	-	-
	Operating weight	kg (lb)	29100 (64150)	-	-	-
	Ground pressure	kgf/cm ² (psi)	0.56 (7.96)	-	-	-
	Overall width	mm (ft-in)	2990 (9' 10")	-	-	-
R290LC-9 LONG REACH	Shoe width	mm (in)	-	-	800 (32)	-
	Operating weight	kg (lb)	-	-	31890 (70310)	-
	Ground pressure	kgf/cm ² (psi)	-	-	0.47 (6.68)	-
	Overall width	mm (ft-in)	-	-	3400 (11' 2")	-
R290LC-9 HIGH WALKER	Shoe width	mm (in)	600 (24)	700 (28)	800 (32)	*710 (28)
	Operating weight	kg (lb)	32140 (70860)	32720 (72140)	33300 (73410)	*33310 (73440)
	Ground pressure	kgf/cm ² (psi)	0.62 (8.82)	0.54 (7.68)	0.48 (6.83)	*0.54 (7.68)
	Overall width	mm (ft-in)	3470 (11' 5")	3570 (11' 9")	3670 (12' 0")	*3580 (11' 9")

* : Double grouser

3) NUMBER OF ROLLERS AND SHOES ON EACH SIDE

Item	Quantity
Carrier rollers	2 EA
Track rollers	9 EA
Track shoes	48 EA

4) SELECTION OF TRACK SHOE

Suitable track shoes should be selected according to operating conditions.

Method of selecting shoes

Confirm the category from the list of applications in **table 2**, then use **table 1** to select the shoe. Wide shoes (categories B and C) have limitations on applications. Before using wide shoes, check the precautions, then investigate and study the operating conditions to confirm if these shoes are suitable.

Select the narrowest shoe possible to meet the required flotation and ground pressure. Application of wider shoes than recommendations will cause unexpected problem such as bending of shoes, crack of link, breakage of pin, loosening of shoe bolts and the other various problems.

※ **Table 1**

Track shoe	Specification	Category
600mm triple grouser	Standard	A
700mm triple grouser	Option	B
710mm double grouser	Option	B
800mm triple grouser	Option	C
900mm triple grouser	Option	C
800mm triple grouser (long reach)	Standard	C

※ **Table 2**

Category	Applications	Precautions
A	Rocky ground, river beds, normal soil	<ul style="list-style-type: none"> · Travel at low speed on rough ground with large obstacles such as boulders or fallen trees
B	Normal soil, soft ground	<ul style="list-style-type: none"> · These shoes cannot be used on rough ground with large obstacles such as boulders or fallen trees · Travel at high speed only on flat ground · Travel slowly at low speed if it is impossible to avoid going over obstacles
C	Extremely soft ground (swampy ground)	<ul style="list-style-type: none"> · Use the shoes only in the conditions that the machine sinks and it is impossible to use the shoes of category A or B · These shoes cannot be used on rough ground with large obstacles such as boulders or fallen trees · Travel at high speed only on flat ground · Travel slowly at low speed if it is impossible to avoid going over obstacles

8. SPECIFICATIONS FOR MAJOR COMPONENTS

1) ENGINE

Item	Specification
Model	Cummins QSB6.7 / HYUNDAI HE 6.7
Type	4-cycle turbocharged diesel engine
Cooling method	Water cooling
Number of cylinders and arrangement	6 cylinders, in-line
Firing order	1-5-3-6-2-4
Combustion chamber type	Direct injection type
Cylinder bore × stroke	107 × 124 mm (4.21" × 4.88")
Piston displacement	6700 cc (409cu in)
Compression ratio	17.2 : 1
Rated gross horse power (SAE J1995)	227 Hp at 1900 rpm (169 kW at 1900 rpm)
Maximum torque	97.0 kgf · m (701 lbf · ft) at 1400 rpm
Engine oil quantity	24 l (6.3 U.S. gal)
Dry weight	556 kg (1226 lb)
High idling speed	1850 ± 50 rpm
Low idling speed	800 ± 100 rpm
Rated fuel consumption	166.3 g/Hp · hr at 1900 rpm
Starting motor	24 V-4.5 kW
Alternator	24 V-50 A
Battery	2 × 12 V × 160 Ah

2) MAIN PUMP

Item	Specification
Type	Variable displacement tandem axis piston pumps
Capacity	2 × 140 cc/rev
Maximum pressure	350 kgf/cm ² (4980 psi) [380 kgf/cm ² (5400 psi)]
Rated oil flow	2 × 252 l /min (66.6 U.S. gpm / 55.4 U.K. gpm)

[] : Power boost

3) GEAR PUMP

Item	Specification
Type	Fixed displacement gear pump single stage
Capacity	15 cc/rev
Maximum pressure	40 kgf/cm ² (570 psi)
Rated oil flow	27 l /min (7.1 U.S. gpm / 5.9 U.K. gpm)

4) MAIN CONTROL VALVE

Item	Specification	
	R290LC-9	R290LC-9 Long reach
Type	10 spools	
Operating method	Hydraulic pilot system	
Main relief valve pressure	350 kgf/cm ² (4980 psi) [380 kgf/cm ² (5400 psi)]	
Port relief valve pressure	Boom	400 kgf/cm ² (5690 psi)
	Arm	400 kgf/cm ² (5690 psi)
	Bucket	400 kgf/cm ² (5690 psi)
		400 kgf/cm ² (5690 psi)
		250 kgf/cm ² (3560 psi)
		270 kgf/cm ² (3840 psi)

[]: Power boost

5) SWING MOTOR

Item	Specification
Type	Axial piston motor
Capacity	169.4 cc/rev
Relief pressure	300 kgf/cm ² (4270 psi)
Braking system	Automatic, spring applied hydraulic released
Braking torque	70 kgf · m (506 lbf · ft)
Brake release pressure	26 kgf/cm ² (370 psi)
Reduction gear type	2 - stage planetary

6) TRAVEL MOTOR

Item	Specification
Type	Variable displacement axial piston motor
Relief pressure	350 kgf/cm ² (4980 psi)
Capacity (max / min, -#0306)	279.1/155 cc/rev
Capacity (max / min, #0307-)	154.8/88.5 cc/rev
Reduction gear type	3-stage planetary
Braking system	Automatic, spring applied hydraulic released
Brake release pressure (-#0306)	15.7 kgf/cm ² (223 psi)
Brake release pressure (#0307-)	9 kgf/cm ² (128 psi)
Braking torque (-#0306)	92 kgf · m (670 lbf · ft)
Braking torque (#0307-)	40 kgf · m (290 lbf · ft)

7) REMOTE CONTROL VALVE

Item		Specification
Type		Pressure reducing type
Operating pressure	Minimum	6.5 kgf/cm ² (92 psi)
	Maximum	26 kgf/cm ² (370 psi)
Single operation stroke	Lever	61 mm (2.4 in)
	Pedal	123 mm (4.84 in)

8) CYLINDER

Item		Specification
Boom cylinder	Bore dia × Rod dia × Stroke	∅ 140 × ∅ 100 × 1465 mm
	Cushion	Extend only
Arm cylinder	Bore dia × Rod dia × Stroke	∅ 150 × ∅ 110 × 1765 mm
	Cushion	Extend and retract
Bucket cylinder	Bore dia × Rod dia × Stroke	∅ 135 × ∅ 95 × 1185 mm
	Cushion	Extend only
Bucket cylinder (LONG REACH)	Bore dia × Rod dia × Stroke	∅ 100 × ∅ 70 × 870 mm
	Cushion	Extend only

※ Discoloration of cylinder rod can occur when the friction reduction additive of lubrication oil spreads on the rod surface.

※ Discoloration does not cause any harmful effect on the cylinder performance.

9) SHOE

Item		Width	Ground pressure	Link quantity	Overall width
R290LC-9	Standard	600 mm (24")	0.56 kgf/cm ² (7.97 psi)	48	3200 mm (10' 6")
	Option	700 mm (28")	0.49 kgf/cm ² (6.97 psi)	48	3300 mm (10' 10")
		800 mm (32")	0.44 kgf/cm ² (6.26 psi)	48	3400 mm (11' 1")
		900 mm (36")	0.40 kgf/cm ² (5.69 psi)	48	3500 mm (11' 5")
R290NLC-9	Standard	600 mm (24")	0.56 kgf/cm ² (7.97 psi)	48	2990 mm (9' 10")
R290LC-9 LONG REACH	Standard	800 mm (32")	0.47 kgf/cm ² (6.68 psi)	48	3400 mm (11' 2")
R290LC-9 HIGH WALKER	Standard	600 mm (24")	0.62 kgf/cm ² (8.82 psi)	48	3470 mm (11' 5")
	Option	700 mm (28")	0.54 kgf/cm ² (7.68 psi)	48	3570 mm (11' 9")
		800 mm (32")	0.48 kgf/cm ² (6.83 psi)	48	3670 mm (12' 0")
		★710 mm (28")	0.54 kgf/cm ² (7.68 psi)	48	3580 mm (11' 9")

★ : Double grouser

10) BUCKET

Item		Capacity		Tooth quantity	Width		
		SAE heaped	CECE heaped		Without side cutter	With side cutter	
R290LC-9 R290NLC-9 H/WALKER	Std	1.27 m ³ (1.66 yd ³)	1.10 m ³ (1.44 yd ³)	5	1290 mm (50.8")	1410 mm (55.5")	
	Opt		0.79 m ³ (1.03 yd ³)	0.70 m ³ (0.92 yd ³)	3	890 mm (35.0")	1010 mm (39.8")
			1.03 m ³ (1.35 yd ³)	0.90 m ³ (1.18 yd ³)	4	1090 mm (42.9")	1210 mm (47.6")
		◆	1.07 m ³ (1.40 yd ³)	0.95 m ³ (1.24 yd ³)	5	1150 mm (45.3")	-
		◆	1.27 m ³ (1.66 yd ³)	1.10 m ³ (1.44 yd ³)	5	1210 mm (47.6")	-
		◆	1.46 m ³ (1.91 yd ³)	1.28 m ³ (1.67 yd ³)	5	1460 mm (57.5")	-
		⊙	1.16 m ³ (1.52 yd ³)	1.00 m ³ (1.05 yd ³)	5	1340 mm (52.8")	-
		⊙	1.49 m ³ (1.95 yd ³)	1.28 m ³ (1.67 yd ³)	5	1620 mm (63.8")	-
			1.50 m ³ (1.96 yd ³)	1.30 m ³ (1.70 yd ³)	6	1490 mm (58.7")	1610 mm (63.4")
			1.73 m ³ (2.26 yd ³)	1.50 m ³ (1.96 yd ³)	6	1700 mm (66.9")	1820 mm (71.7")
			1.85 m ³ (2.42 yd ³)	1.60 m ³ (2.09 yd ³)	5	1800 mm (70.9")	1920 mm (75.6")
LONG REACH	Std	0.52 m ³ (0.68 yd ³)	0.46 m ³ (0.60 yd ³)	5	935 mm (36.8")	1035 mm (40.8")	

◆ : Heavy duty bucket

⊙ : Rock bucket

9. RECOMMENDED OILS

Use only oils listed below. Do not mix different brand oil.

Please use HYUNDAI genuine oil and grease.

Service point	Kind of fluid	Capacity ℓ (U.S. gal)	Ambient temperature °C (°F)						
			-50 (-58)	-30 (-22)	-20 (-4)	-10 (14)	0 (32)	10 (50)	20 (68)
Engine oil pan	Engine oil	24 (6.3)	★SAE 5W-40						
			SAE 30						
			SAE 10W						
			SAE 10W-30						
			SAE 15W-40						
Swing drive	Gear oil	6.0 (1.6) ^{★1} 11.0 (3.0)	★SAE 75W-90						
Final drive		9.5×2 (-#0317) (2.5×2)	SAE 80W-90						
		8.0×2 (#0318-) (2.1×2)							
Hydraulic tank	Hydraulic oil	Tank; 190 (50) System; 330 (87)	★ISO VG 15						
			ISO VG 32						
			ISO VG 46						
			ISO VG 68						
Fuel tank	Diesel fuel	500 (132)	★ASTM D975 NO.1						
			ASTM D975 NO.2						
Fitting (grease nipple)	Grease	As required	★NLGI NO.1						
			NLGI NO.2						
Radiator (reservoir tank)	Mixture of antifreeze and water 50 : 50	35 (9.2)	Ethylene glycol base permanent type						
			★Ethylene glycol base permanent type (60 : 40)						

SAE : Society of Automotive Engineers

API : American Petroleum Institute

ISO : International Organization for Standardization

NLGI : National Lubricating Grease Institute

ASTM : American Society of Testing and Material

★ : Cold region

Russia, CIS, Mongolia

^{★1} Service when the grease
inlent exists on the equipment