

GROUP 3 PILOT CIRCUIT

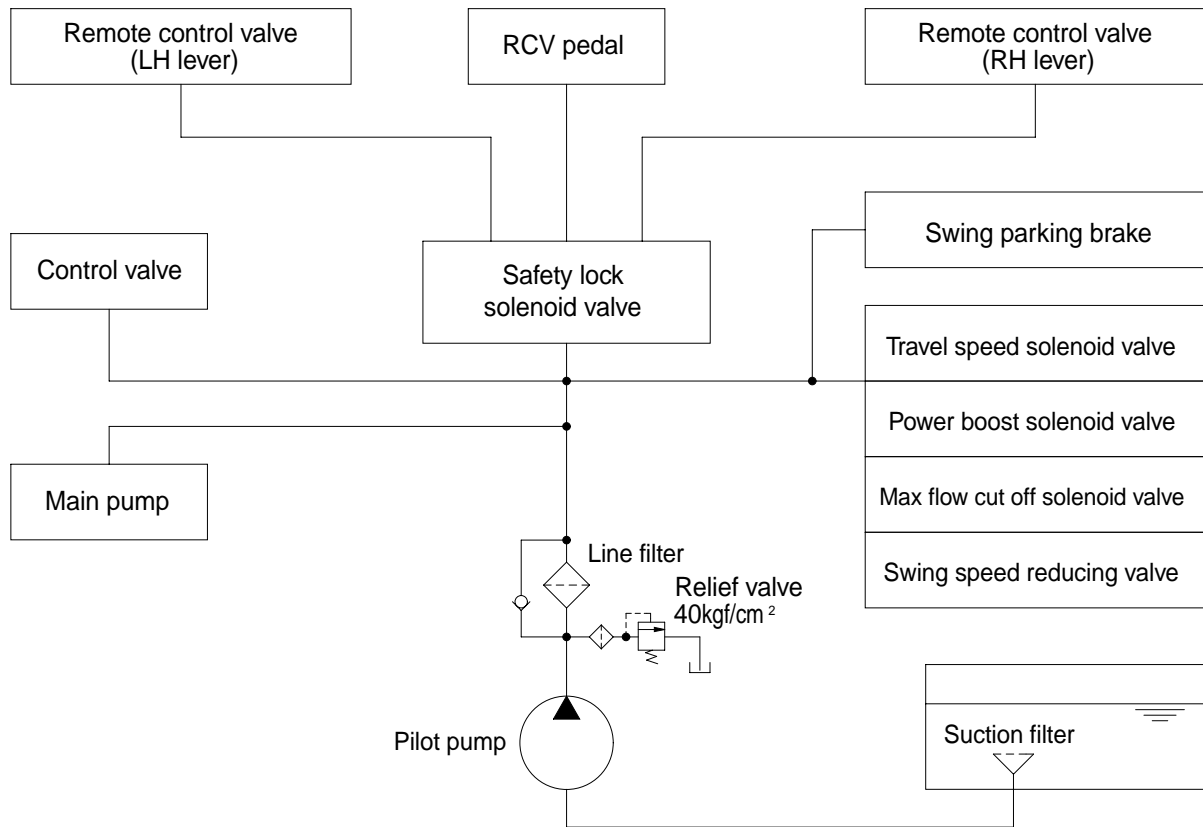

The pilot circuit consists of suction circuit, delivery circuit and return circuit.

The pilot pump is provided with relief valve, receives the oil from the hydraulic tank through the suction filter.

The discharged oil from the pilot pump flows to the remote control valve through line filter, EPPR valve, solenoid valve assemblies, swing parking brake, main control valve and safety lock solenoid valve.

1. SUCTION, DELIVERY AND RETURN CIRCUIT

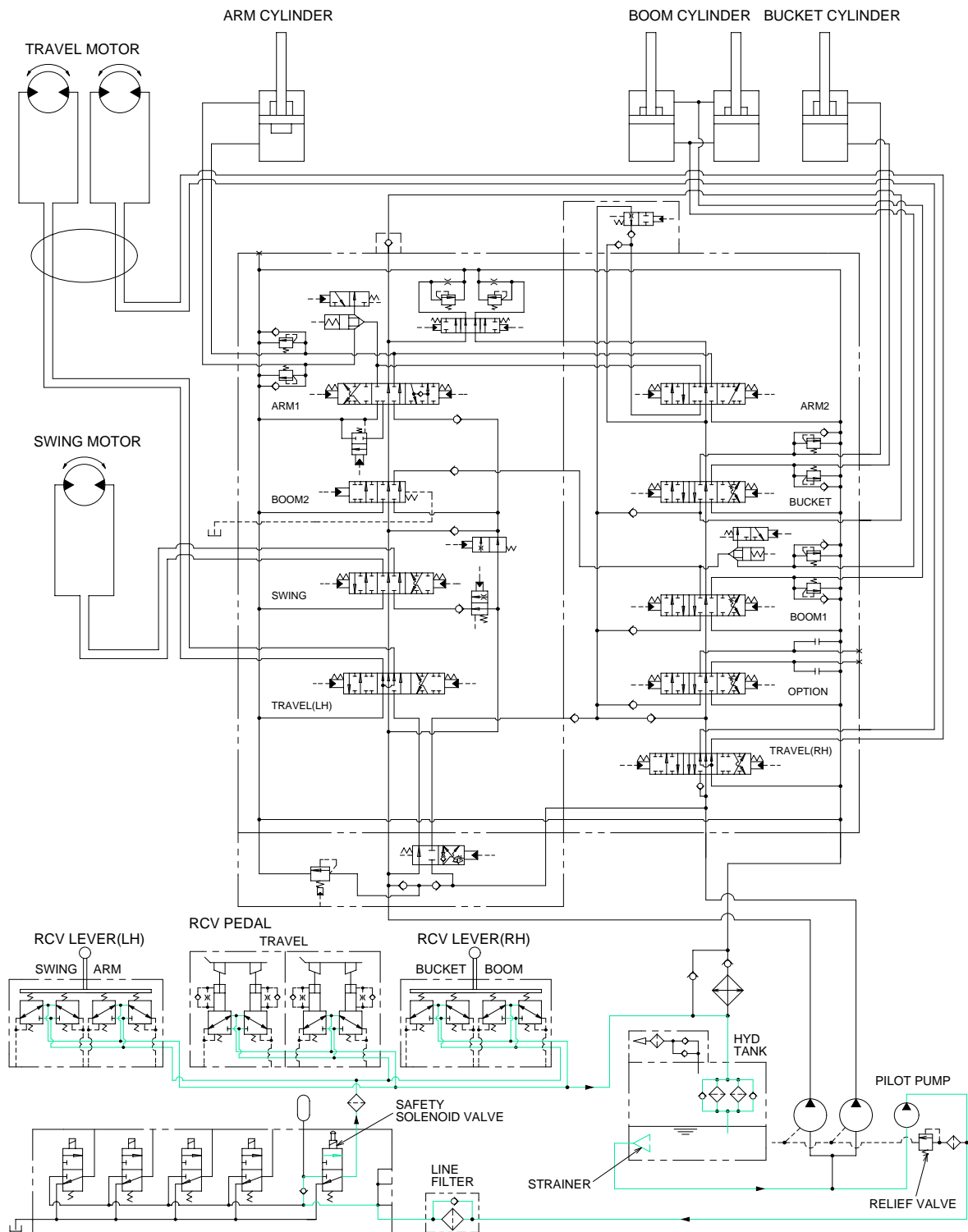

The pilot pump receive oil from the hydraulic tank. The discharged oil from the pilot pump flows to the safety solenoid valve through the line filter. The oil is filtered by the line filter. The pilot relief valve is provided in the pilot pump for limiting the pilot circuit pressure.

The oil filtered by line filter flows remote control valve through safety solenoid valve.

The return oil from remote control valve returned to hydraulic tank.

2. SAFETY SOLENOID VALVE(SAFETY LEVER)

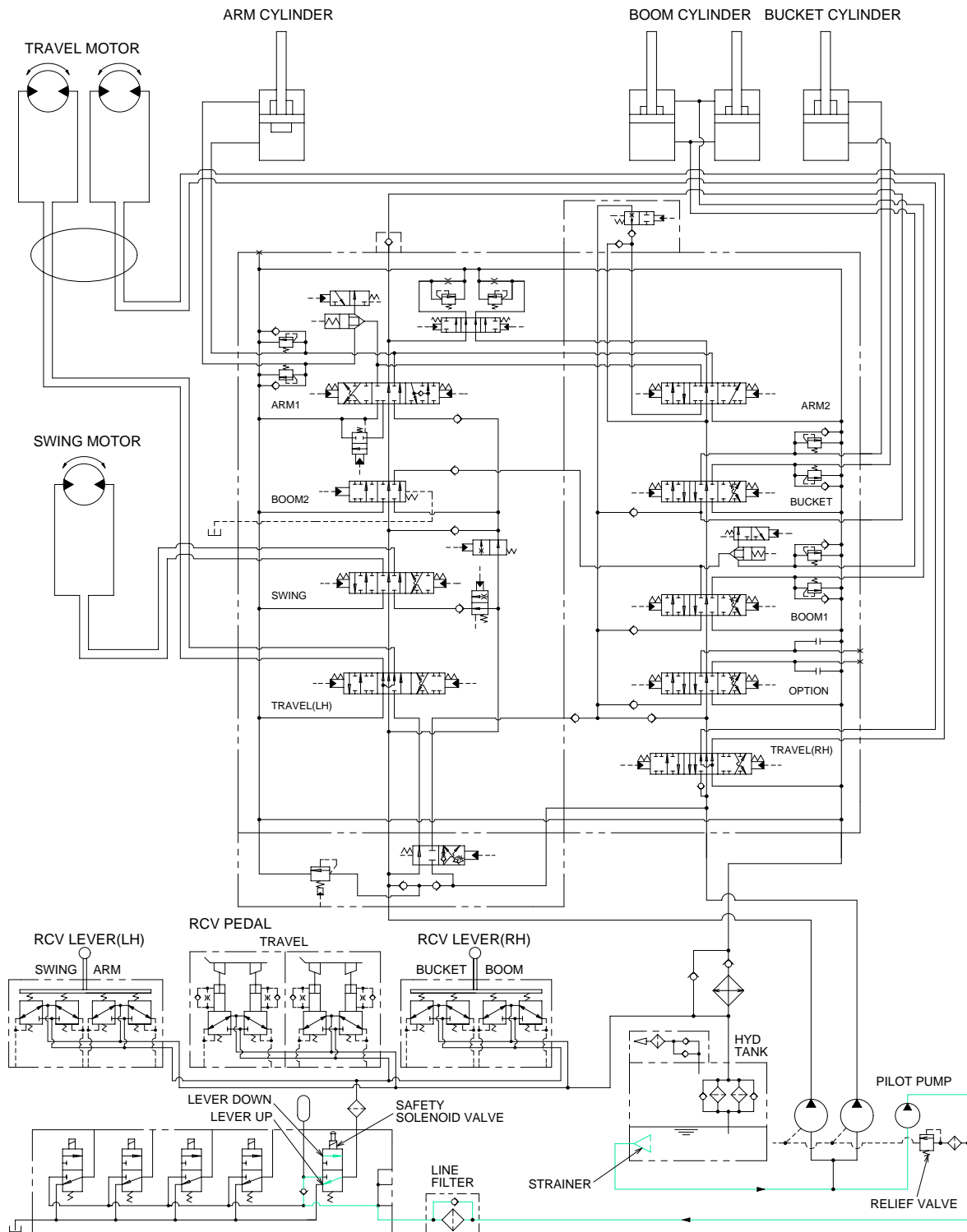

When the lever of the safety solenoid valve is moved downward, oil flows into the remote control valve through solenoid valve and line filter.

When the lever of the safety solenoid valve moved upward, oil does not flows into the remote control valve, because of blocked by the spool.

3. MAIN RELIEF PRESSURE CHANGE CIRCUIT

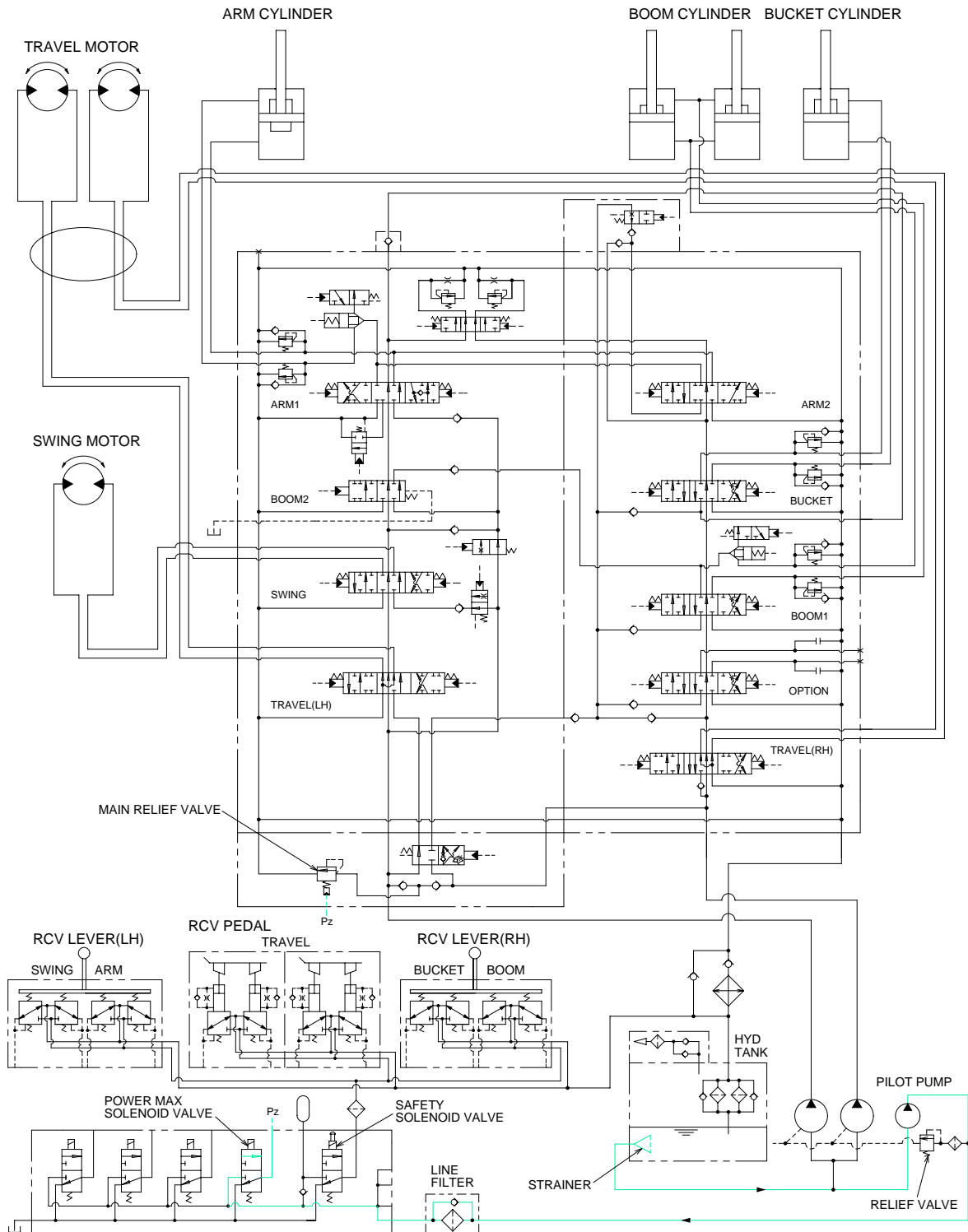

When the power max switch on the left control lever is pushed ON, the power max solenoid valve is actuated, the discharged oil from the pilot pump into Pz port of the main relief valve of main control valve ; Then the setting pressure of the main control valve is raises from 330kgf/cm² to 360kgf/cm² for increasing the digging power. And even when press continuously, it is canceled after 8 seconds.

4. SWING PARKING BRAKE RELEASE

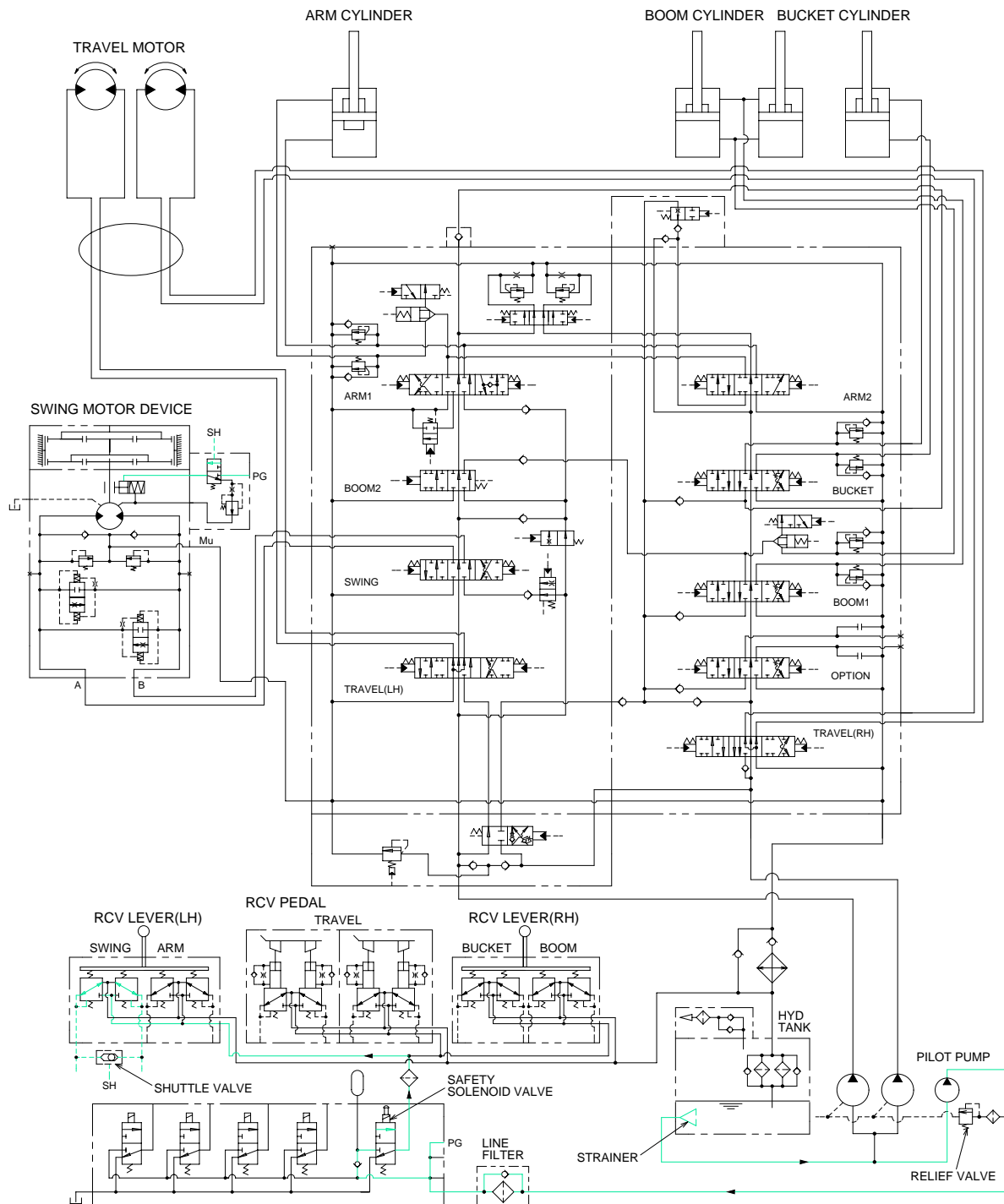

When the swing control lever is operated, the pilot oil flows to SH port of shuttle valve, this pressure move spool so, discharged oil from pilot pump flows to PG port.

This pressure is applied to swing motor disc cylinder, thus the brake released.

When the swing control lever is set neutral position, oil in the swing motor disc cylinder is drain, thus the brake is applied.

5. TRAVEL SPEED CONTROL PRESSURE

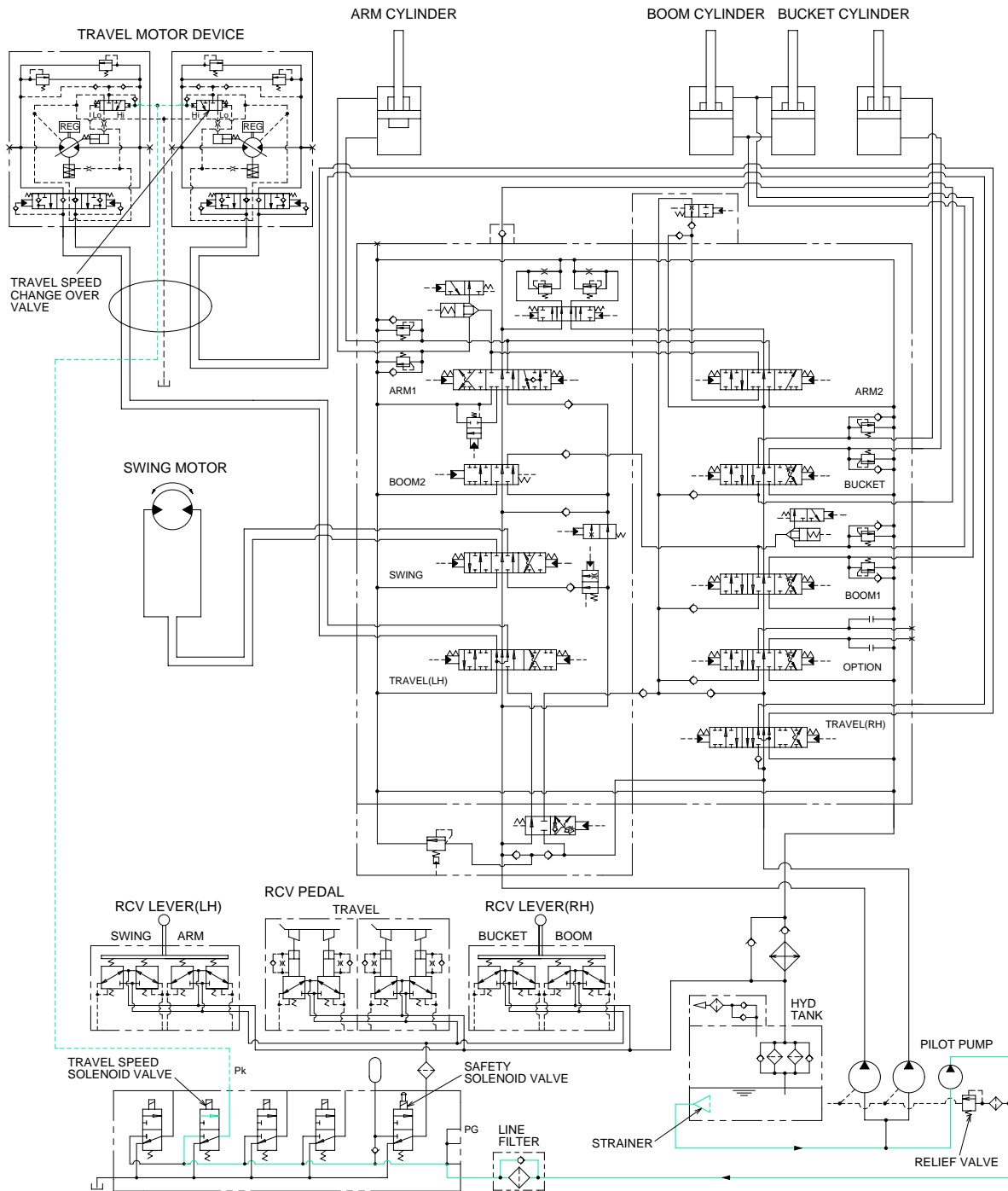

When the travel speed solenoid valve was placed in the Hi position, the pressure oil from pilot pump through line filter flows to port(Pk) of travel speed change over valve, and the control piston is pushed up, thus minimizing the displacement.

When the travel speed solenoid valve was placed in the Lo position, the oil of Pk port return to the tank and the control piston is returned, thus maximizing the displacement.

6. MAX FLOW CUT OFF SYSTEM

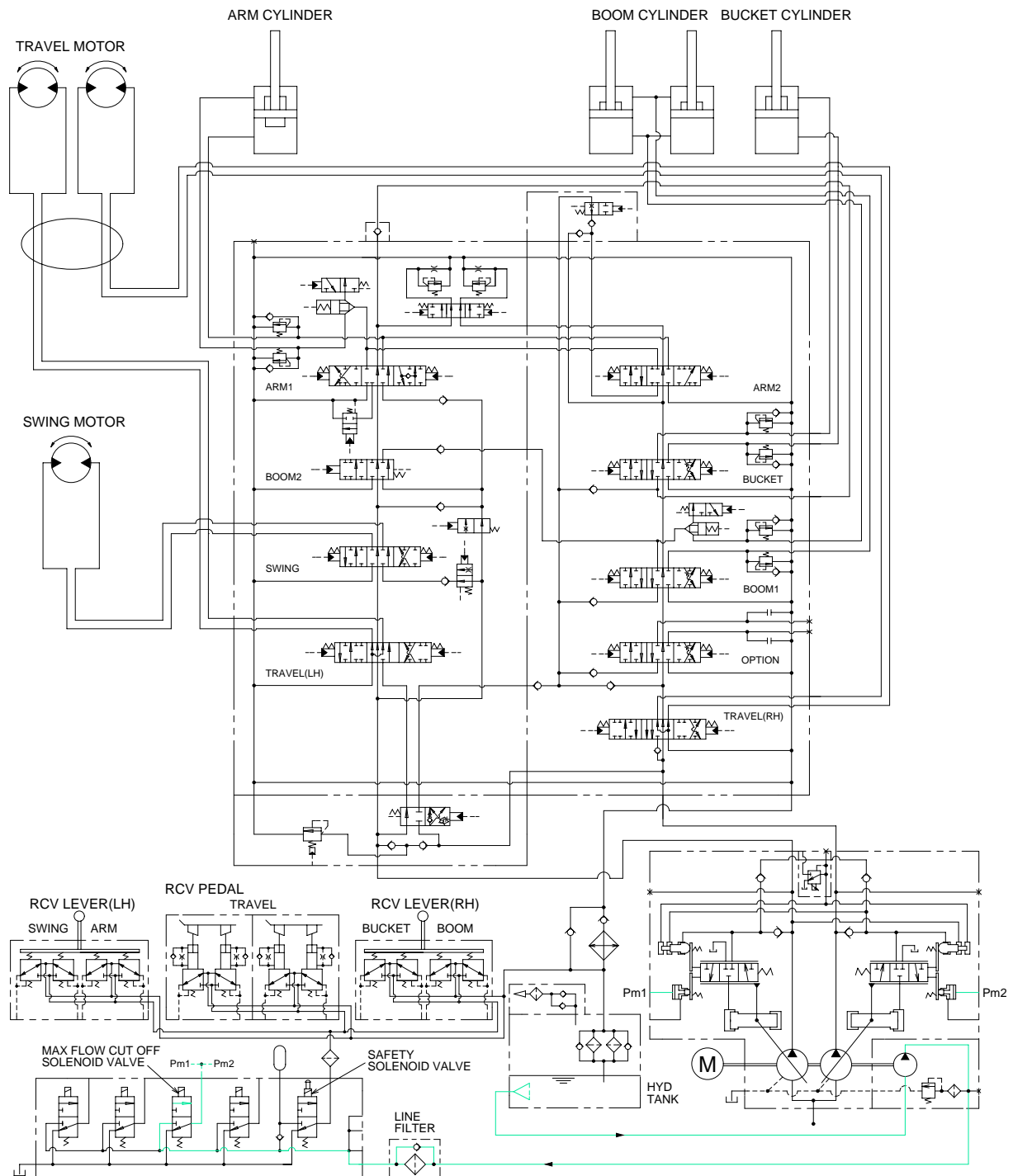

When the breaker operation mode is selected on the cluster, max flow cut off solenoid valve actuates automatically. Thus pilot pressure(Pm1,Pm2) is sent to the regulator and pump discharge volume is decreased.

7. BOOM PRIORITY SYSTEM

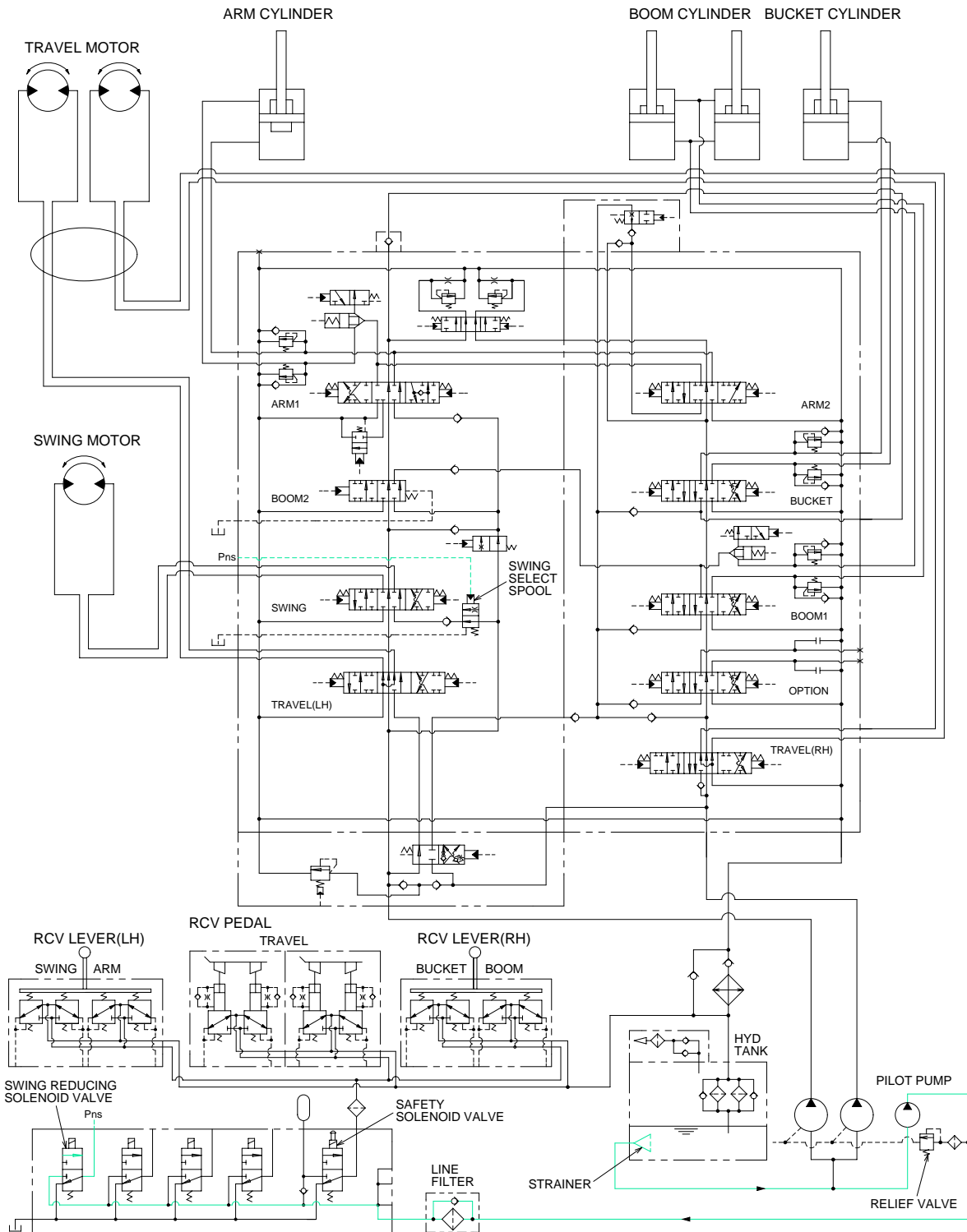

When carrying out the combined operation of swing and boom or arm of the left control valve, the boom or arm speed can be lowered than operating speed of swing. When the heavy duty working mode in work mode is selected on the cluster, swing reducing solenoid valve actuates automatically.

The oil from pilot pump flows into the solenoid valve through the line filter.

Pns pressure from solenoid valve change the swing select spool and decreases the oil flow rate to the swing section by orifice.

This is called the boom priority system.