

GROUP 4 HYDRAULIC SYSTEM

HYDRAULIC COMPONENTS MOUNTING 1

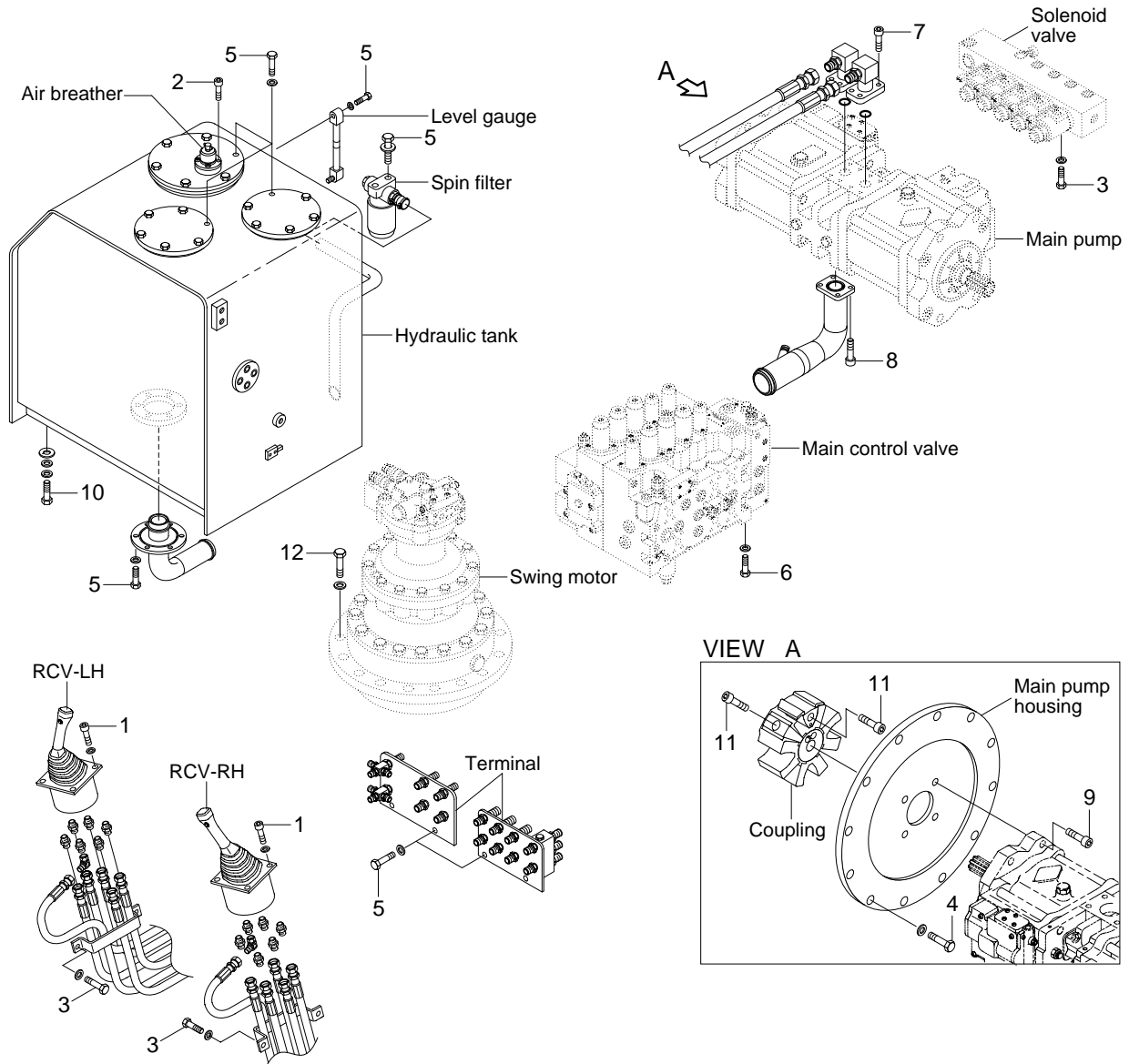

· Tightening torque

Item	Size	kgf · m	lbf · ft
1	M 6 × 1.0	1.05 ± 0.2	7.6 ± 1.45
2	M 6 × 1.0	1.44 ± 0.3	10.4 ± 2.2
3	M 8 × 1.25	2.5 ± 0.5	18.1 ± 3.6
4	M10 × 1.5	2.81 ± 0.3	20.3 ± 2.2
5	M10 × 1.5	6.9 ± 1.4	49.9 ± 10.1
6	M12 × 1.75	12.2 ± 1.3	88.9 ± 9.4

Item	Size	kgf · m	lbf · ft
7	M12 × 1.75	14.7 ± 2.2	106 ± 15.9
8	M16 × 2.0	29.7 ± 4.5	215 ± 32.5
9	M20 × 2.5	42 ± 4.5	304 ± 32.5
10	M20 × 2.5	46 ± 5.0	333 ± 36
11	M20 × 2.5	46.5 ± 2.5	336 ± 18.1
12	M20 × 2.5	57.9 ± 8.7	419 ± 62.9

HYDRAULIC COMPONENTS MOUNTING 2

Double acting attachment piping

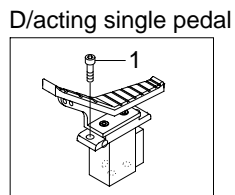
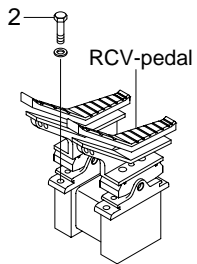
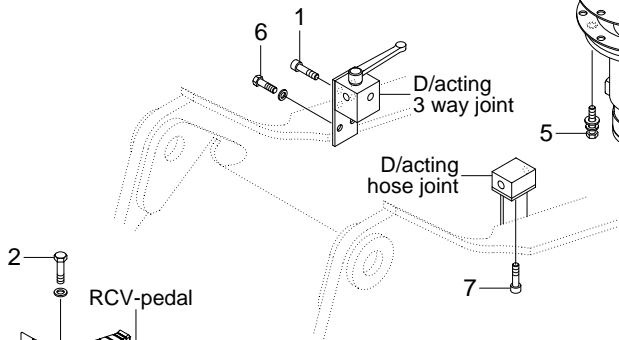
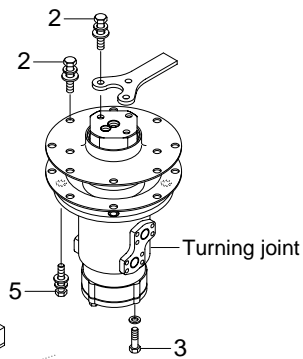
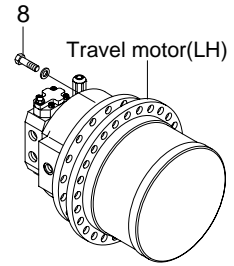
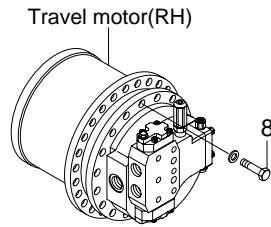
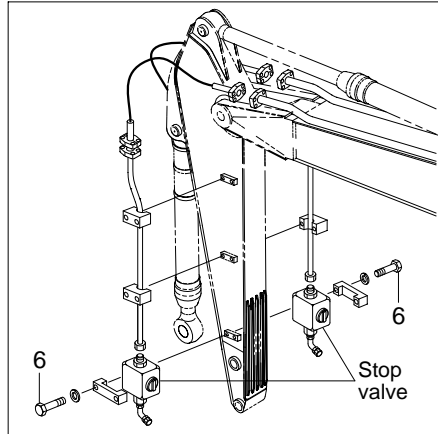

Boom safety lock system

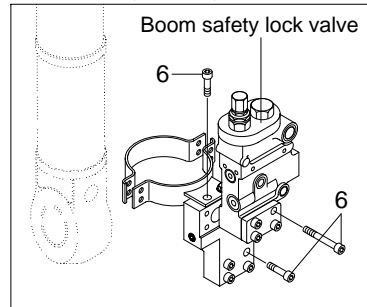

Arm safety lock system

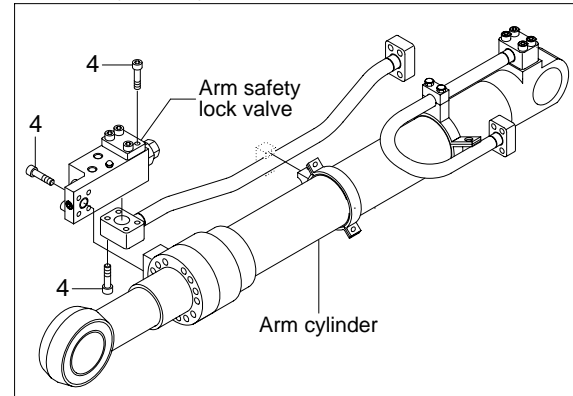

· Tightening torque

Item	Size	kgf · m	lbf · ft
1	M 8 × 1.25	4.05 ± 0.8	29.3 ± 5.8
2	M10 × 1.5	6.9 ± 1.4	49.9 ± 10.1
3	M12 × 1.75	12.3 ± 1.3	88.9 ± 9.4

Item	Size	kgf · m	lbf · ft
4	M12 × 1.75	12.0 ± 1.3	86.8 ± 9.4
5	M12 × 1.75	12.8 ± 3.0	92.6 ± 21.7
6	M24 × 3.0	100 ± 10	723 ± 72.3

HYDRAULIC COMPONENTS MOUNTING 3

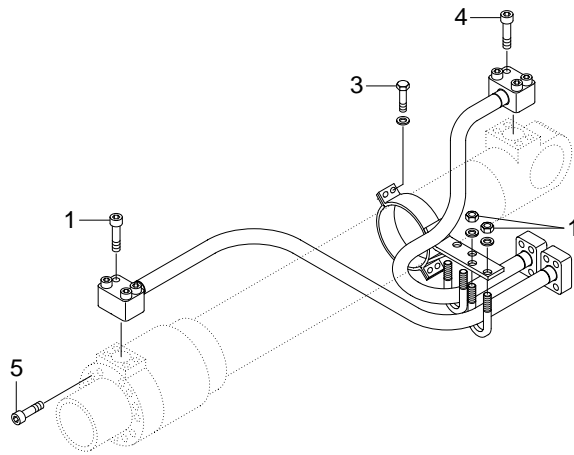

BOOM CYLINDER

Solenoid valve

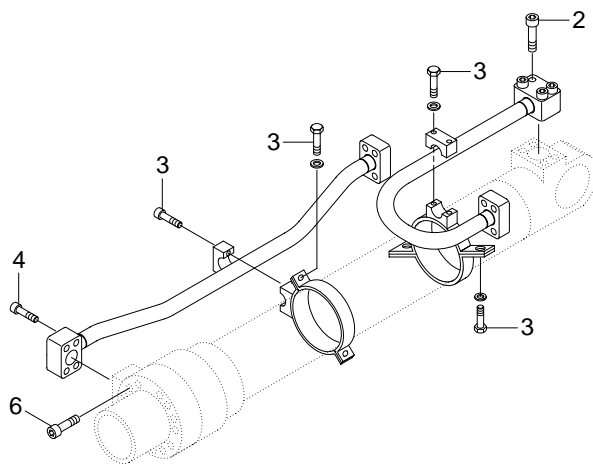
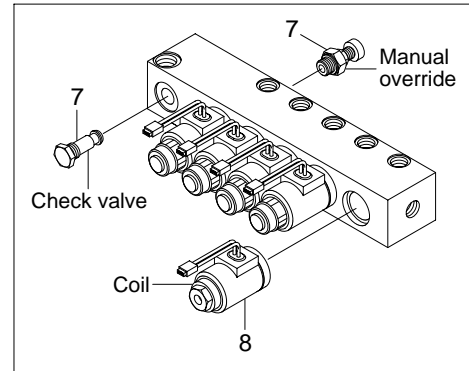

ARM CYLINDER

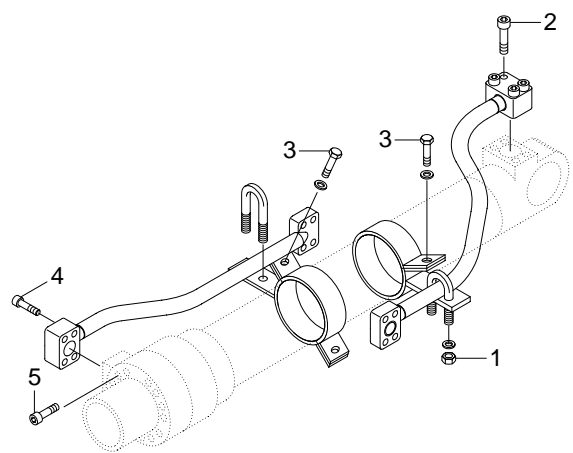

BUCKET CYLINDER

· Tightening torque

Item	Size	kgf · m	lbf · ft
1	M10 × 1.5	3.2 ± 0.3	23.1 ± 2.2
2	M10 × 1.5	5.4 ± 0.5	39.1 ± 3.6
3	M12 × 1.75	5.5 ± 0.6	39.8 ± 4.3
4	M12 × 1.75	9.4 ± 1.0	68.0 ± 7.2

Item	Size	kgf · m	lbf · ft
5	M18 × 2.5	32 ± 3.0	232 ± 21.7
6	M20 × 2.5	46 ± 5.0	333 ± 36.2
7	M22 × 2.5	4.1	29.6
8	M27 × 3.0	5.1	36.9