

GROUP 7 RCV LEVER

1. REMOVAL AND INSTALL

1) REMOVAL

- (1) Lower the work equipment to the ground and stop the engine.
- (2) Loosen the breather slowly to release the pressure inside the hydraulic tank.
- ▲ Escaping fluid under pressure can penetrate the skin causing serious injury.
- (3) Loosen the socket bolt(3).
- (4) Remove the cover of the console box.
- (5) Disconnect pilot line hoses (4).
- (6) Remove the pilot valve assembly(1, 2).
weight 4.8kg × 2EA(11lb)
※ When removing the pilot valve assembly, check that all the hoses have been disconnected.

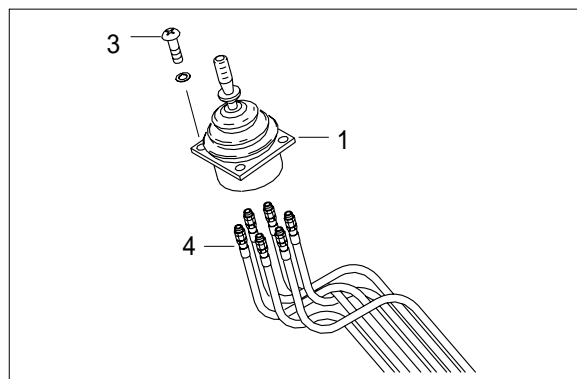

2) INSTALL

- (1) Carry out installation in the reverse order to removal.
- (2) Confirmed the hydraulic oil level and check the hydraulic oil leak or not.

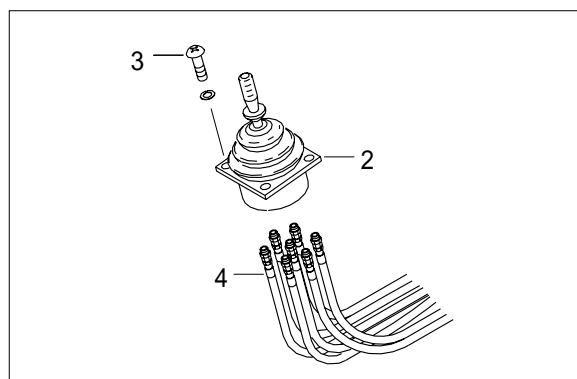

2. DISASSEMBLY AND ASSEMBLY

1) STRUCTURE(RH - LEVER)(1/2)

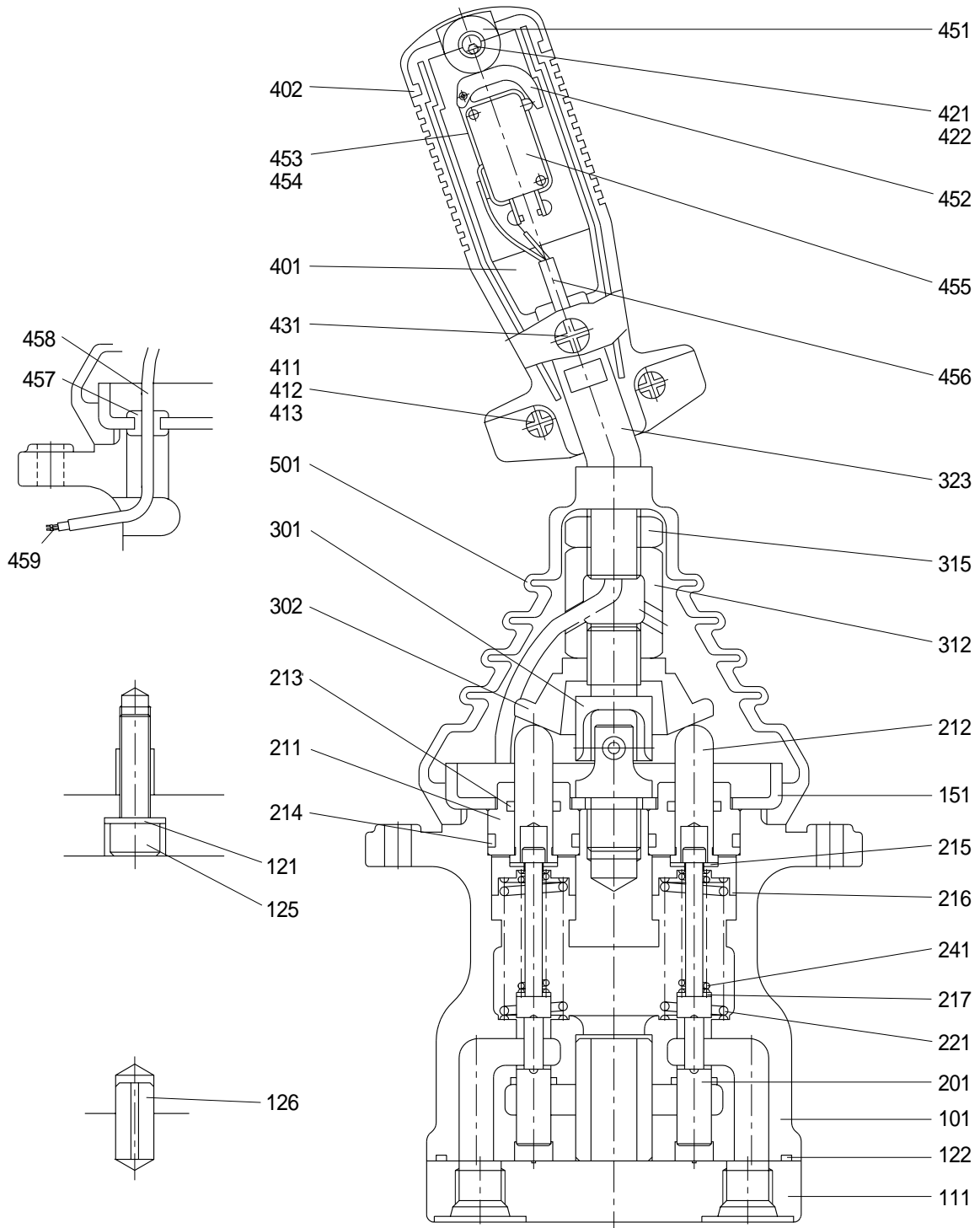

101	Casing	216	spring seat	421	Screw 2
111	Port plate	217	Washer 2	422	Nut
121	Seal washer	221	spring	431	Screw 3
122	O-ring	241	Spring	451	Roller
125	Hexagon socket bolt	301	Joint	452	Lever
126	Spring pin	302	Plate	453	Switch seat 1
131	Bushing	312	Adjusting nut	454	Switch seat 2
151	Plate	315	Lock nut	455	Switch
201	Spool	323	Handle bar	456	Cord
211	Plug	401	Handle	457	Bushing
212	Push rod	402	Handle cap	458	Tube
213	Seal	411	Screw 1	459	Terminal
214	O-ring	412	Nut	501	Bellows
215	washer 1	413	Washer		

2) STRUCTURE(LH - LEVER)(2/2)

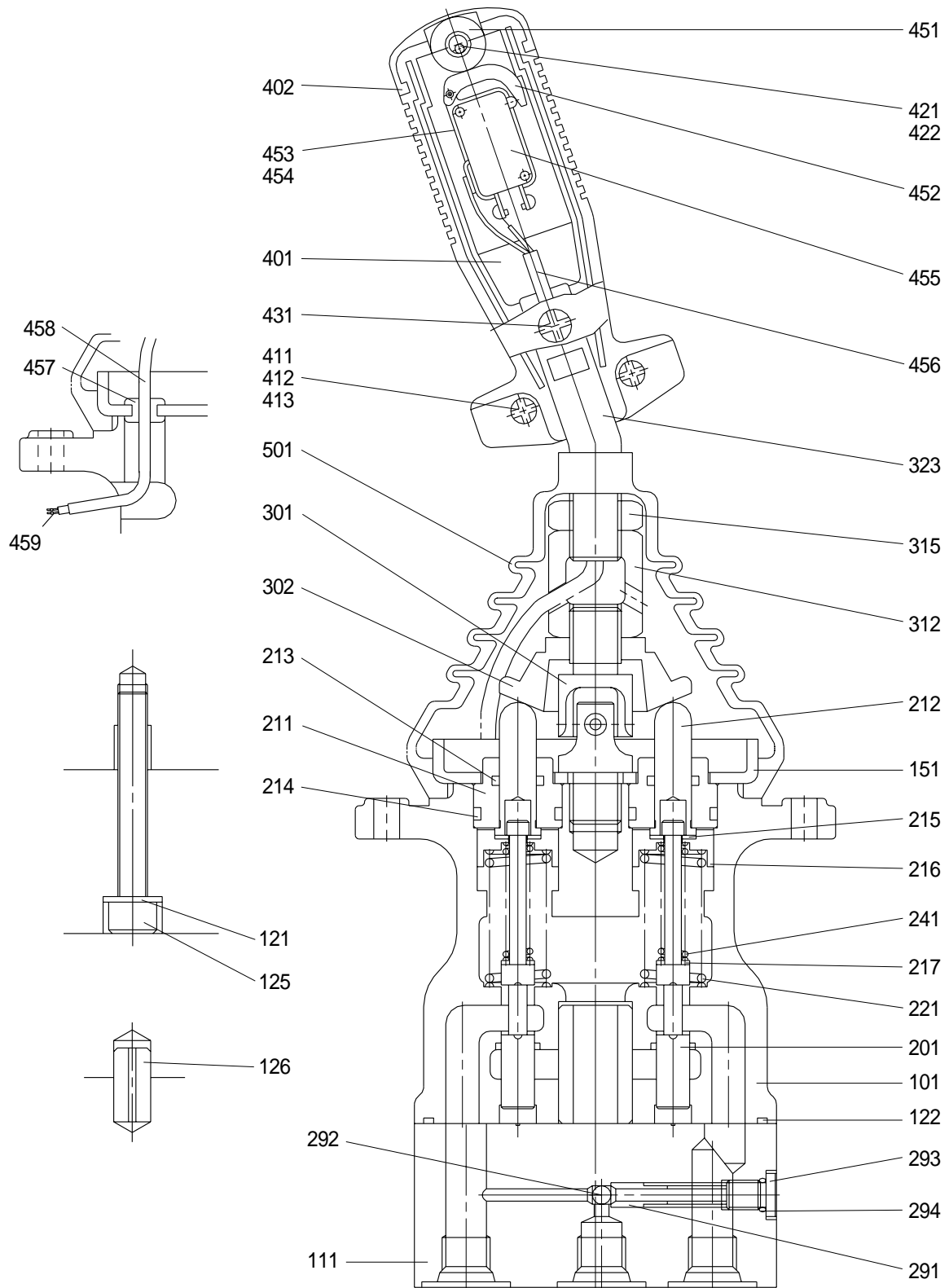

101	Casing	221	spring	421	Screw 2
111	Port plate	241	Spring	422	Nut
121	Seal washer	291	Seat	431	Screw 3
122	O-ring	292	Steel ball	451	Roller
125	Hexagon socket bolt	293	Plug	452	Lever
126	Spring pin	294	O-ring	453	Switch seat 1
131	Bushing	301	Joint	454	Switch seat 2
151	Plate	302	Plate	455	Switch
201	Spool	312	Adjusting nut	456	Cord
211	Plug	315	Lock nut	457	Bushing
212	Push rod	323	Handle bar	458	Tube
213	Seal	401	Handle	459	Terminal
214	O-ring	402	Handle cap	471	Insulation cap
215	washer 1	411	Screw 1	472	Rubber tube
216	spring seat	412	Nut	501	Bellows
217	Washer 2	413	Washer		

2) TOOLS AND TIGHTENING TORQUE

(1) Tools

Tool name	Remark	
Allen wrench	6	
Spanner	22	
	27	
(+) Driver	Length 150	
(-) Driver	wide 4 ~ 5	
Torque wrench	Capable of tightening with the specified torques.	

(2) Tightening torque

Part name	Item	Size	Torque	
			kgf · m	lbf · ft
Port plate	111	PF 1/4	0.37	2.7
Socket head bolt	125	M 8	3.0 ± 0.3	21.7 ± 2.2
Joint	301	M 14	3.5 ± 0.25	25.3 ± 1.8
Adjusting nut	312	M 14	5.0 ± 0.35	36.2 ± 2.5
Lock nut	315	M 14	5.2 ± 0.35	36.2 ± 2.5
Screw 1	411	M 4	0.05	0.36
Screw 2	421	M 4	0.01	0.07
Screw 3	431	M 5	0.09 ± 0.01	0.65 ± 0.07
Plug(For LH)	293	M 12	1.1 ± 0.1	7.96 ± 0.7

3) DISASSEMBLY

- (1) Clean pilot valve with kerosene.
 - ※ Put blind plugs into all ports
- (2) Fix pilot valve in a vise with copper (or lead) sheets.

- (3) Remove end of bellows(501) from casing (101) and take it out upwards.



- ※ For valve with switch, remove cord(456) also through hole of casing.



- (4) Loosen lock nut(315) and adjusting nut (312) with spanners on them respectively, and take out handle section as one body.



- (5) Loosen adjusting nut(312) and disk(302) with spanners on them respectively, and remove them.

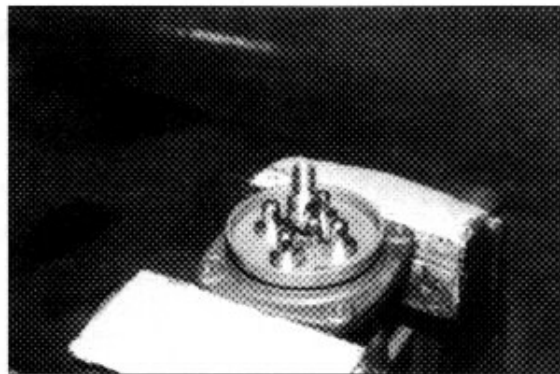
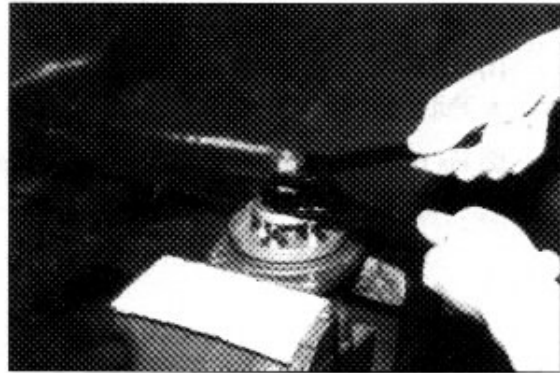

- (6) Turn joint anticlockwise to loosen it, utilizing jig (special tool).

※ When return spring(221) is strong in force, plate(151), plug(211) and push rod(212) will come up on loosening joint. Pay attention to this.



(7) Remove plate(151).



(8) When return spring(221) is weak in force, plug(211) stays in casing because of sliding resistance of O-ring.

- ※ Take it out with minus screwdriver.
Take it out, utilizing external periphery groove of plug and paying attention not to damage it by partial loading.
- ※ During taking out, plug may jump up due to return spring(221) force.
Pay attention to this.

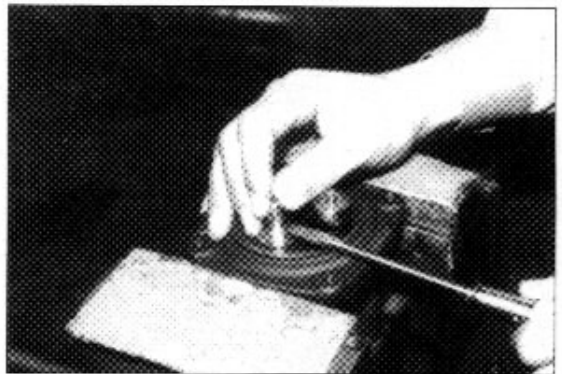

(9) Remove reducing valve subassembly and return spring(221) out of casing.
Record relative position of reducing valve subassembly and return springs.

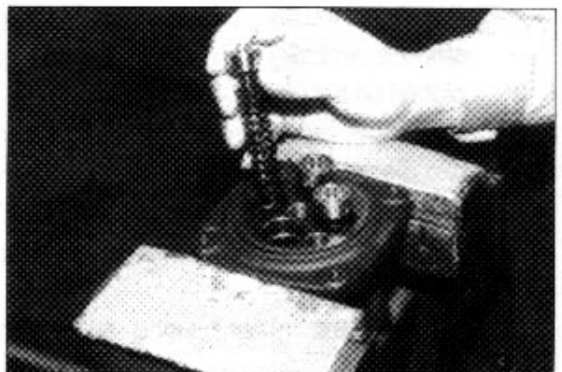

(10) Loosen hexagon socket head cap screws with hexagon socket screw key.



- (11) Remove port plate(111) and O-ring(122) out of casing.

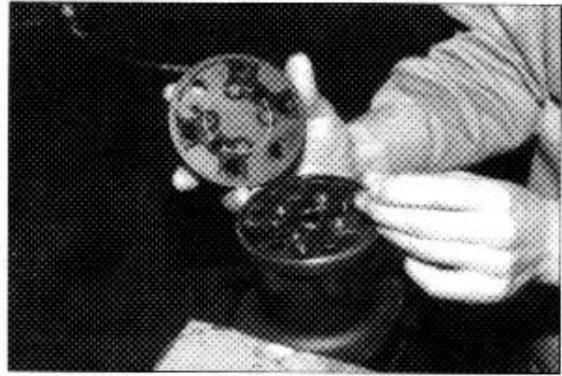

- (12) Take out bushing(131) from casing.



- (13) For disassembling reducing valve section, stand it vertically with spool(201) bottom placed on flat workbench.

Push down spring seat(216) and remove two pieces of semicircular washers1(215) with tip of small minus screwdriver.

- * Pay attention not to damage spool surface.
- * Do not push down spring seat more than 6mm.

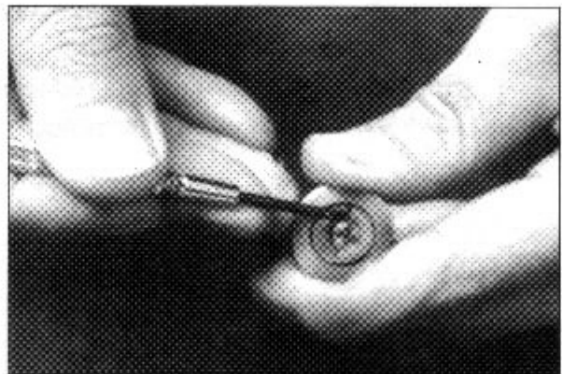

- (14) Separate spool(201), spring seat(216), spring(241) and washer 2(217) individually.

- * Until being assembled, they should be handled as one subassembly group.

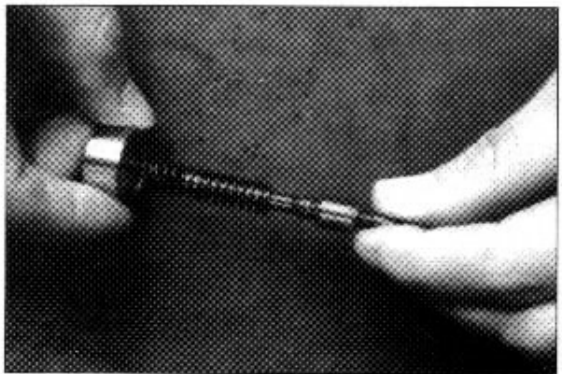

(15) Take push rod(212) out of plug(211).

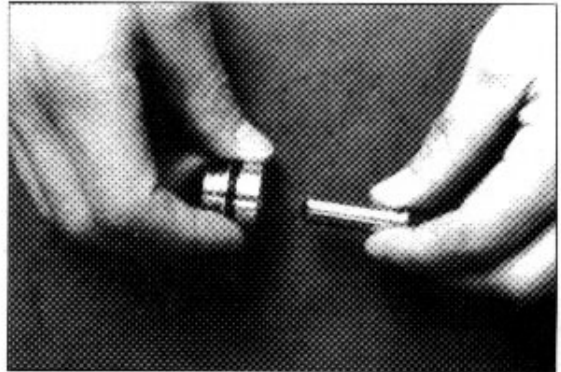

(16) Remove O-ring(214) and seal(213) from plug(211).
Use small minus screwdriver or so on to remove this seal.

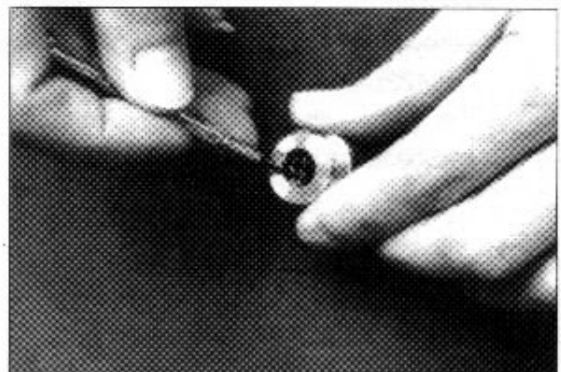

(17) Remove lock nut(315) and then bellows (501).



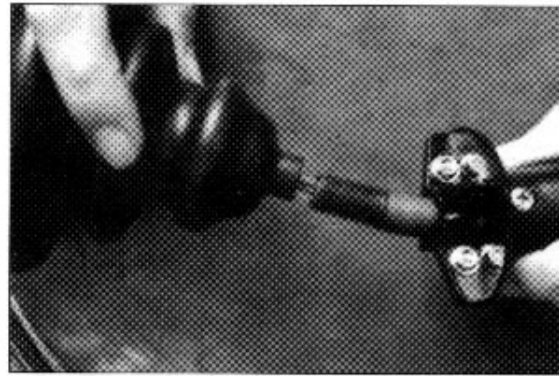

- (18) Remove handle cap(402).
※ For valve without switch, remove cap(403), too.



- (19) Loosen machine screw 2(421) with plus screwdriver and remove it together with nut(422).
※ For valve with 2-point switch, roller(451) can be taken out.



- (20) Loosen machine screws 3 & 1(431 & 411) with plus screwdriver and remove machine screw 1, nut(412) and plain washer(413).

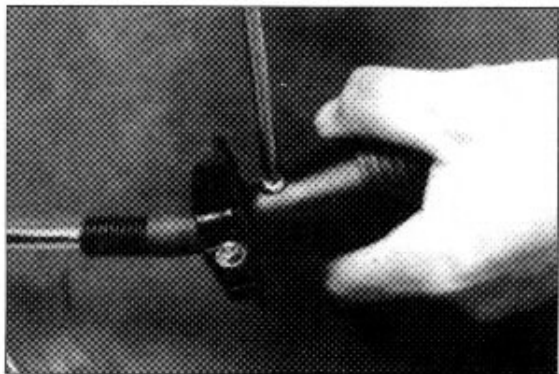

②1) Disassemble handle(401) into two.

- ※ For valve with switch, switch lever (452), switch(455) and switch seats 1 & 2(453 & 454) can be taken out.

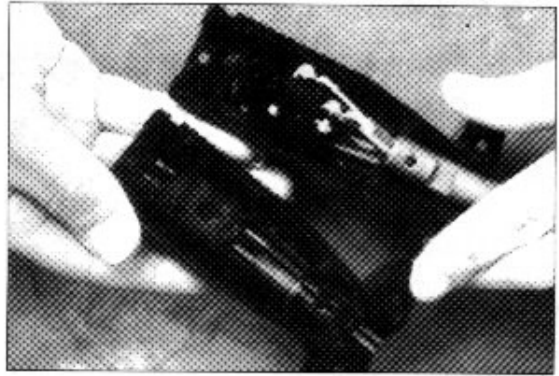

②2) Cleaning of parts

- ① Put all parts in rough cleaning vessel filled with kerosene and clean them (rough cleaning)
 - ※ If dirty part is cleaned with kerosene just after putting it in vessel, it may be damaged. Leave it in kerosene for a while to loosen dust and dirty oil.
 - ※ If this kerosene is polluted, parts will be damaged and functions of reassembled valve will be degraded. Therefore, control cleanliness of kerosene fully.
- ② Put parts in final cleaning vessel filled with kerosene, turning it slowly to clean them even to their insides(finish cleaning).
 - ※ Do not dry parts with compressed air, since they will be damaged and/or rusted by dust and moisture in air.

②3) Rust prevention of parts.

- Apply rust-preventives to all parts.
- ※ If left as they after being cleaned, they will be rusted and will not display their functions fully after being reassembled.

4) ASSEMBLY

- (1) Assemble bushing(131) and O-ring(122) into casing(101).

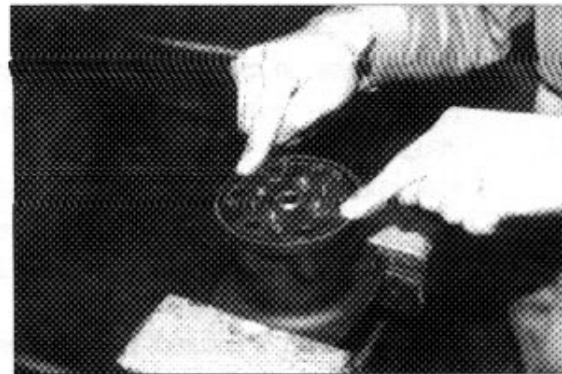
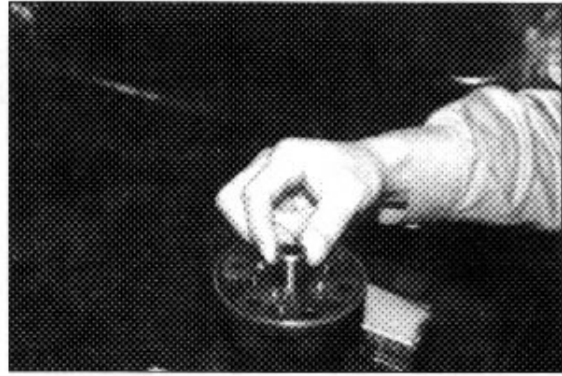

- (2) Fit port plate to casing(101) with hexagon socket head cap screws(125) and seal washers(121).

※ Keep such assembling position that spring pin(126) can enter into casing hole.



- (3) Tighten hexagon socket head cap screws(125) to the specified torque.
* Tighten two bolts alternately and slowly.

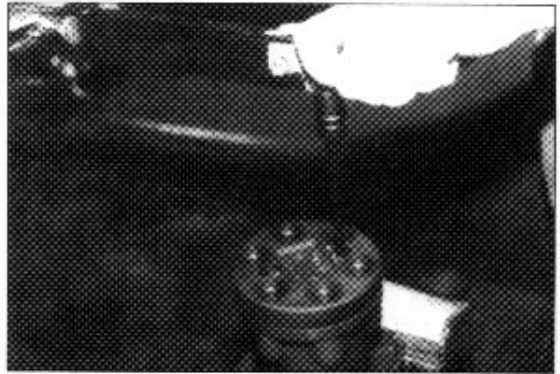

- (4) Put washer 2(217), spring(241) and spring seat(216) onto spool(201) in this order.

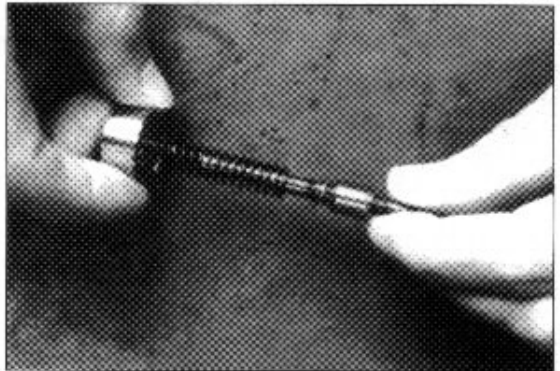

- (5) Stand spool vertically with its bottom placed on flat workbench, and with spring seat pushed down, put two pieces of semicircular washers 1(215) on spring seat without piling them on.
* Assemble washer 1(215) so that its sharp edge side will be caught by head of spool.
Do not push down spring seat more than 6mm.



- (6) Assemble spring(221) into casing.
Assemble reducing valve subassembly into casing.
* Assemble them to their original positions.



(7) Assemble O-ring(214) onto plug(211).

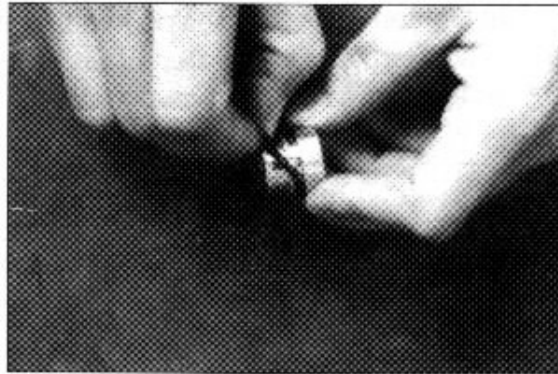

(8) Assemble seal(213) to plug(211).

※ Assemble seal in such lip direction as shown below.

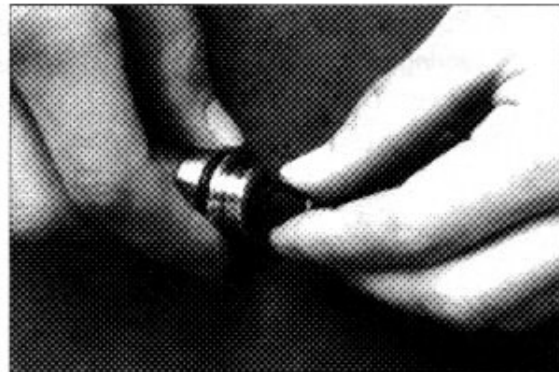

(9) Assemble push rod(212) to plug(211).

※ Apply working oil on push-rod surface.

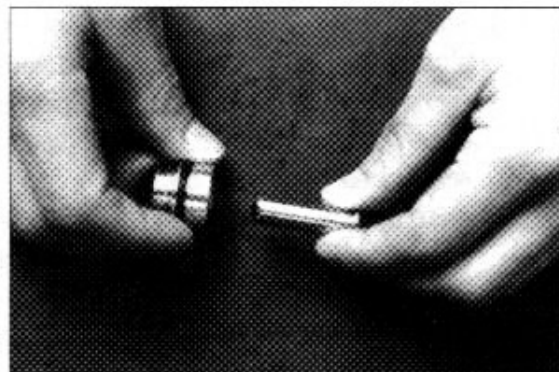

(10) Assemble plug subassembly to casing.

※ When return spring is weak in force, subassembly stops due to resistance of O-ring.



(11) When return spring is strong in force, assemble 4 sets at the same time, utilizing plate(151), and tighten joint(301) temporarily.



(12) Fit plate(151).

(13) Tighten joint(301) with the specified torque to casing, utilizing jig.



(14) Assemble disk(302) to joint(301).
※ Screw it to position that it contacts with 4 push rods evenly.
※ Do not screw it over.



(15) Assemble adjusting nut(312), apply spanner to width across flat of disk(302) to fix it, and tighten adjusting nut to the specified torque.

※ During tightening, do not change position of disk.

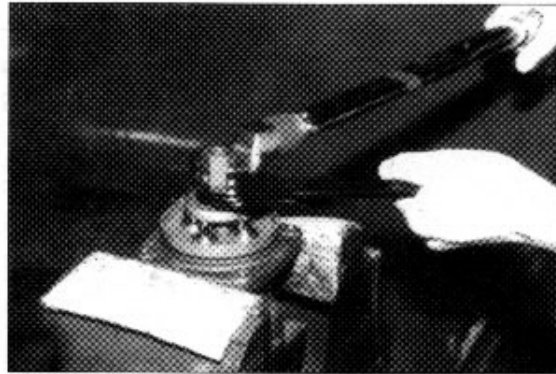

(16) Tighten machine screw 3(431) to the specified torque to fix handle bar and handle.



(17) For valve with switch, assemble parts for switch to handle.

※ Pay attention to projections/ depression for assembling on switch seat, switch, switch lever, etc.



(18) Assemble remaining handle(401).

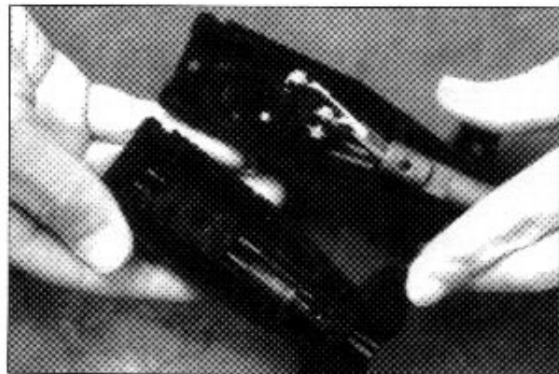

(19) Assemble cap(403) and tighten machine screw 2(421) and nut(422) to their specified torques.

- * For valve with switch, assemble roller (451) in stead of cap and tighten them. In this time confirm that the clearance between roller and handle(401) is 0.5 to 1.5mm.

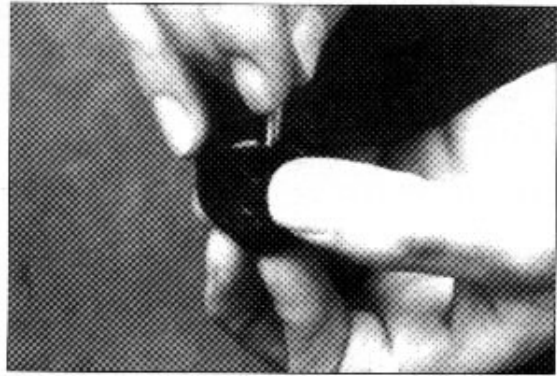

(20) Tighten remaining machine screws 3 (431) to the specified torque.

(21) Tighten machine screws 1(411), plain washer(413) and nuts(412) to the specified torque.

- * Apply loctite #241 to threaded sections of machine screws 1, 2 and 3.

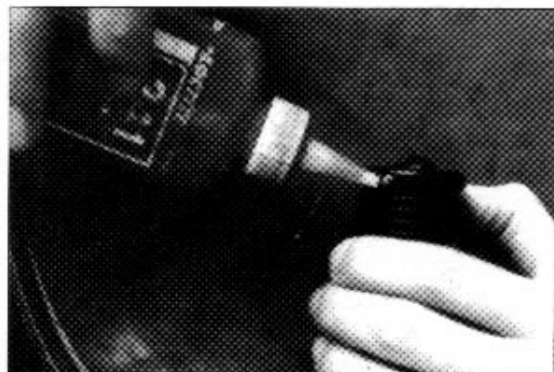

(22) Fit handle cap(402).



- 23) Fit bellows(501) and lock nut(315), and handle subassembly is assembled completely.

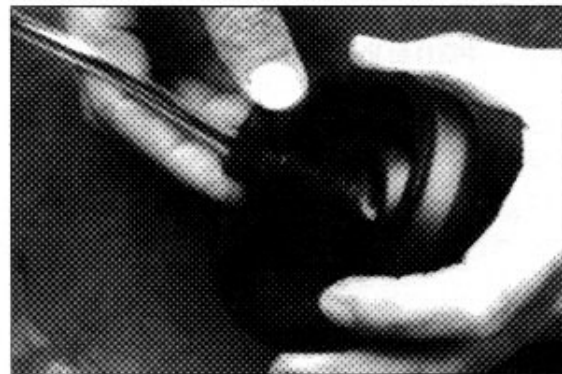
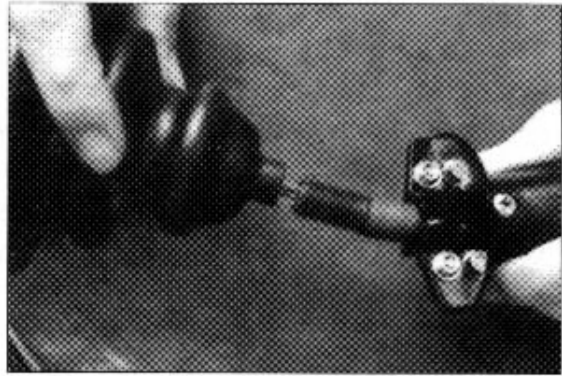

- 24) Pull out cord(456) and tube(458) through adjusting nut hole provided in direction 60° to 120° from casing hole.



- 25) Assemble bushing(457) to plate and pass cord and tube through it.
* Provide margin necessary to operation.



- 26) Determine handle direction, tighten lock nut(315) to specified torque to fix handle.



- 27) Apply grease to rotating section of joint and contacting faces of disk and push rod.



- 28) Assemble lower end of bellows to casing.



- 29) Inject volatile rust-preventives through all ports and then put blind plugs in ports.