

GROUP 7 FUNCTION AND ELECTRICAL CIRCUIT

1. ONE TOUCH DECELERATION FUNCTION

- 1) When one touch deceleration function is selected by touching the switch on, the one touch-deceleration lamp on the cluster turns on, at the same time the CPU controller receives and one touch-deceleration signal from the cluster.
- 2) When one touch deceleration function is selected by touching the switch ON, the CPU controller receives the signal, it moves the engine governor motor lever to the low idle position in order to cut down engine speed to one touch deceleration speed (1000 rpm). Thereby fuel consumption and noise are reduced.
- 3) When the one touch-deceleration switch is touched again and the lamp turns OFF, the CPU controller moves the governor motor lever quickly back to the position set before. So it is possible to restart the work quickly by returning engine speed to the high rpm in a few seconds.

4) Logic table

	Auto deceleration lamp	
	ON	OFF
Signal	Low(GND)	High
Function	Actuated	Canceled

※ Default : One touch deceleration lamp ON
The cluster turns ON.

· Circuit diagram

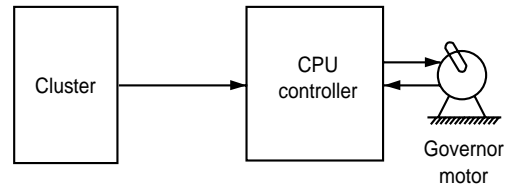

2. TRAVEL SPEED HI/LO FUNCTION

- 1) When the travel speed switch is switched ON/OFF, the lamp on the cluster changes from rabbit(HI)to turtle(Lo) and the CPU controller receives the signal.
- 2) When the CPU controller receives the switch signal of ON(rabbit), it activates the travel speed solenoid valve to change the travel speed onto high.

3) Logic table

	Travel speed switch	
	ON	OFF
Signal	Low	High
Voltage(V)	0(GND)	5
Lamp	Rabbit	Turtle

※ Default : Travel speed lamp lights at Lo(turtle) on the cluster.

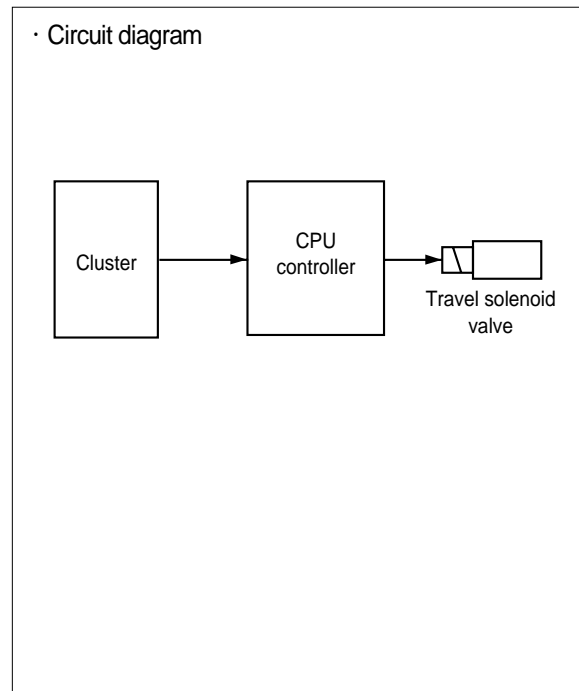

3. ENGINE SPEED UP/DOWN FUNCTION

- 1) Increasing(speed up) or decreasing(speed down) is possible by touching the engine speed up switch or the engine speed down switch on the cluster. When one of them is touched, CPU controller receives the signal and moves the engine governor motor lever to high or low position a little bit.

2) Logic table

	Engine speed UP/DOWN switch	
	ON	OFF
Signal	Low	High
Voltage(V)	0 (GND)	5

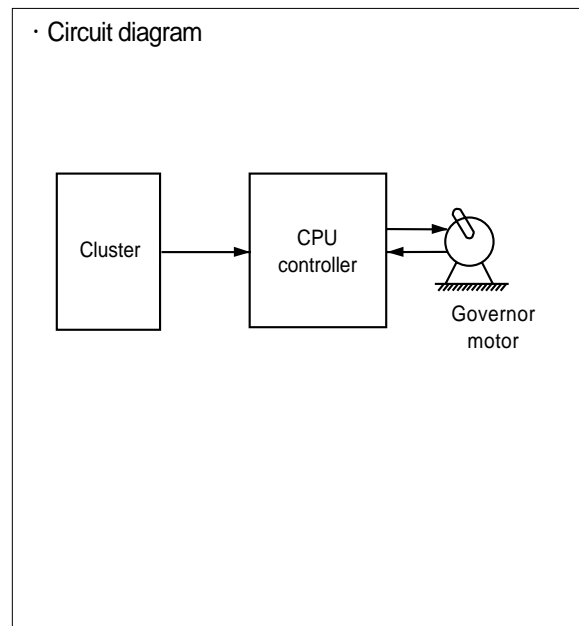

4. ENGINE SPEED SENSING FUNCTION

- 1) Engine speed sensor mounted on the engine sends AC voltage signals to CPU controller, after being rectified into rectangular pulse signals by the CPU controller, they are displayed as engine rpm counter on the 7-segment displays of the cluster.
- 2) When the engine speed drops below the reference rpm of each mode, the CPU controller reduces the pump discharge amount through engine speed feedback to match engine output power with pump absorption power in the optimal condition.

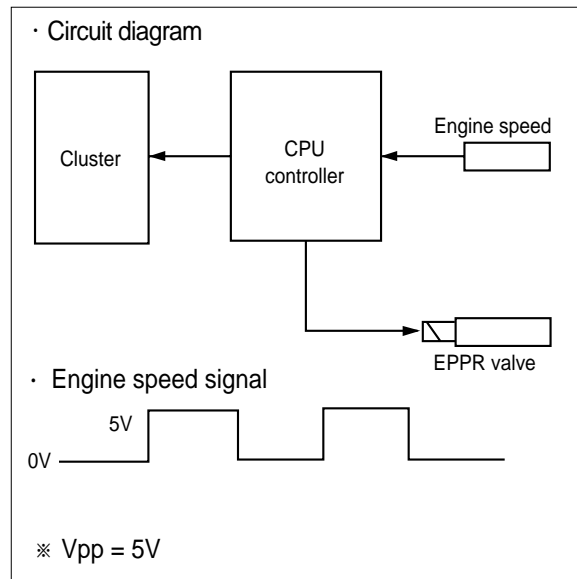

5. BATTERY CHARGE WARNING FUNCTION

- 1) When alternator generated voltage drops below 26V DC after engine starts, the CPU controller sends battery charge warning buzzer drive signal and lamp drive signal to cluster and the warning buzzer and work in condition of that the generated voltage by alternator is less than 26V DC.

2) Logic table

Condition	$\geq 26V$	$< 26V$	Description
Signal	High(5V)	Low(0V)	CPU Controller
Lamp & buzzer	OFF	ON	Cluster

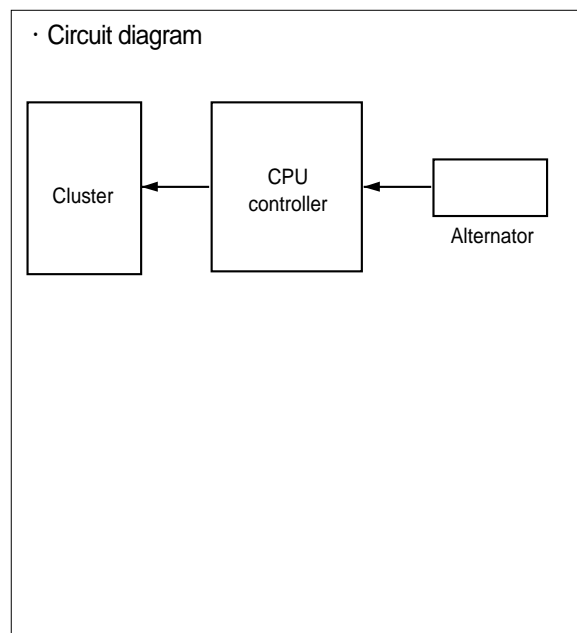

6. HYDRAULIC OIL TEMP WARNING FUNCTION

1) When the CPU controller receives hydraulic oil temperature signals(analog voltage signal) from the hydraulic oil temperature sensor, it converts them into digital signals. If the temperature increases above 100°C , the CPU controller sends hydraulic oil temperature warning buzzer signal and lamp signal to cluster.

So the warning buzzer and lamp ON the cluster work in condition of that the temperature is above 100°C

2) Logic table

Condition	≥ 100°C	< 100°C	Description
Signal	Low(GND)	High(5V)	CPU Controller
Lamp & buzzer	OFF	ON	Cluster

· Circuit diagram

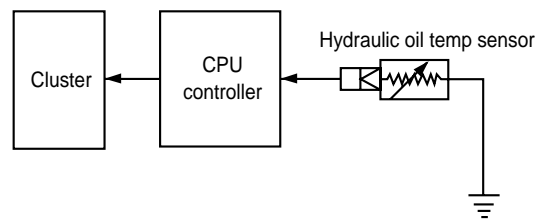

7. AUTOMATIC WARMING UP FUNCTION

1) Cluster reads engine coolant temperature through the temperature sensor, and if the coolant temperature is less than 30°C , it turns the warming-up lamp ON and sends warming-up control signal to the CPU controller.

2) When the CPU controller receives the warming-up control signal from the cluster, it changes mode set to "F" mode and engine speed also increases from one touch deceleration speed to "F" mode speed.

3) If the coolant temperature increases upto 30°C , or an operator changes mode set among the warming up function, the CPU controller cancels the automatic warming up function.

· Circuit diagram

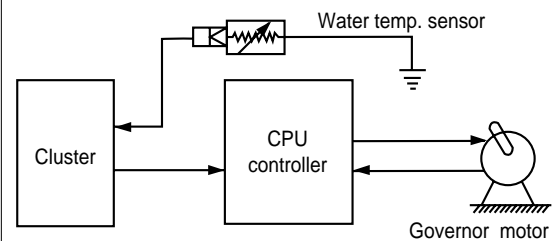

4) Logic table(1)

	Condition	Function
Actuated	- Coolant temperature : less than 30°C (after engine run)	- Mode : "F" after 10 seconds of low idling - Warming up time : at least 10 minutes - Warming-up lamp : ON
Canceled	- Coolant temperature : above 30°C - Warming up time : above 10 minute - Changed mode set by operator ★ If any of the above conditions is applicable, the automatic warming-up function is canceled	- Default mode - Default mode - Changed mode
Warming-up lamp	Coolant temperature : above 30°C	Warming-up lamp : OFF

5) Logic table(2)

	Coolant temp. ≤30°C	Coolant temp. >30°C	Description
Signal	Low(0V)	High(5V)	Cluster
Warming-up lamp	ON	OFF	
Mode	F	Default	CPU controller

8. ENGINE OVERHEAT PREVENTION FUNCTION

- 1) When the engine coolant boils upto 110°C, the overheat switch is ON. and if the temperature drops to 100°C, the switch is OFF.
 - 2) When the overheat switch is ON, engine overheat warning buzzer and lamp work and mode set is changed to "F" mode automatically on the cluster.
 - 3) If the coolant temperature drops to 100°C or mode set is changed among the function, the cluster sends the overheat prevention cancel signal to the CPU controller. Thereby the CPU controller returns the mode to the mode set before.
- ※ Even if the overheat prevention function is canceled by mode change, the overheat warning lamp turns OFF only when the overheat switch is OFF, that is, the coolant temperature is less than 100°C

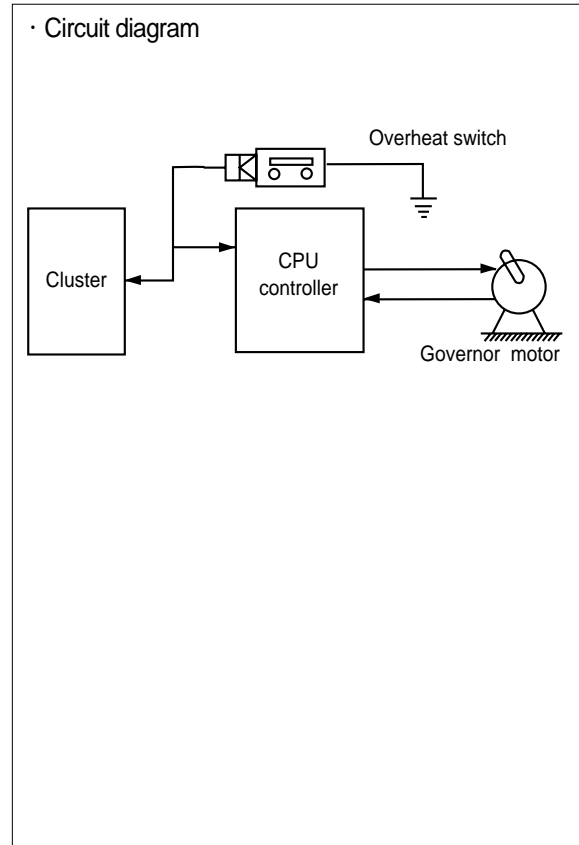

4) Logic table(1)

Description	Condition	Function
Actuated	- Coolant temperature : above 110°C	- Mode : "H", "S", "L" → "F" - Overheat warning lamp & buzzer : ON
Canceled	- Coolant temperature : less than 100°C - Changed mode by operator ※ If any of the above conditions is applicable, engine overheat prevention function is canceled	- Return to the mode set before - Hold on the changed mode
Overheat warning lamp	- Coolant temperature : less than 100°C	- Lamp OFF

5) Logic table(2)

	Overheat switch	
	ON	OFF
Condition	Coolant temp : above 110°C	Coolant temp : less than 100°C
Signal	Low(GND)	High(5V)
Lamp & buzzer (cluster)	ON	OFF
Mode set (CPU controller)	F	Default