

GROUP 4 HYDRAULIC SYSTEM

HYDRAULIC COMPONENTS MOUNTING 1

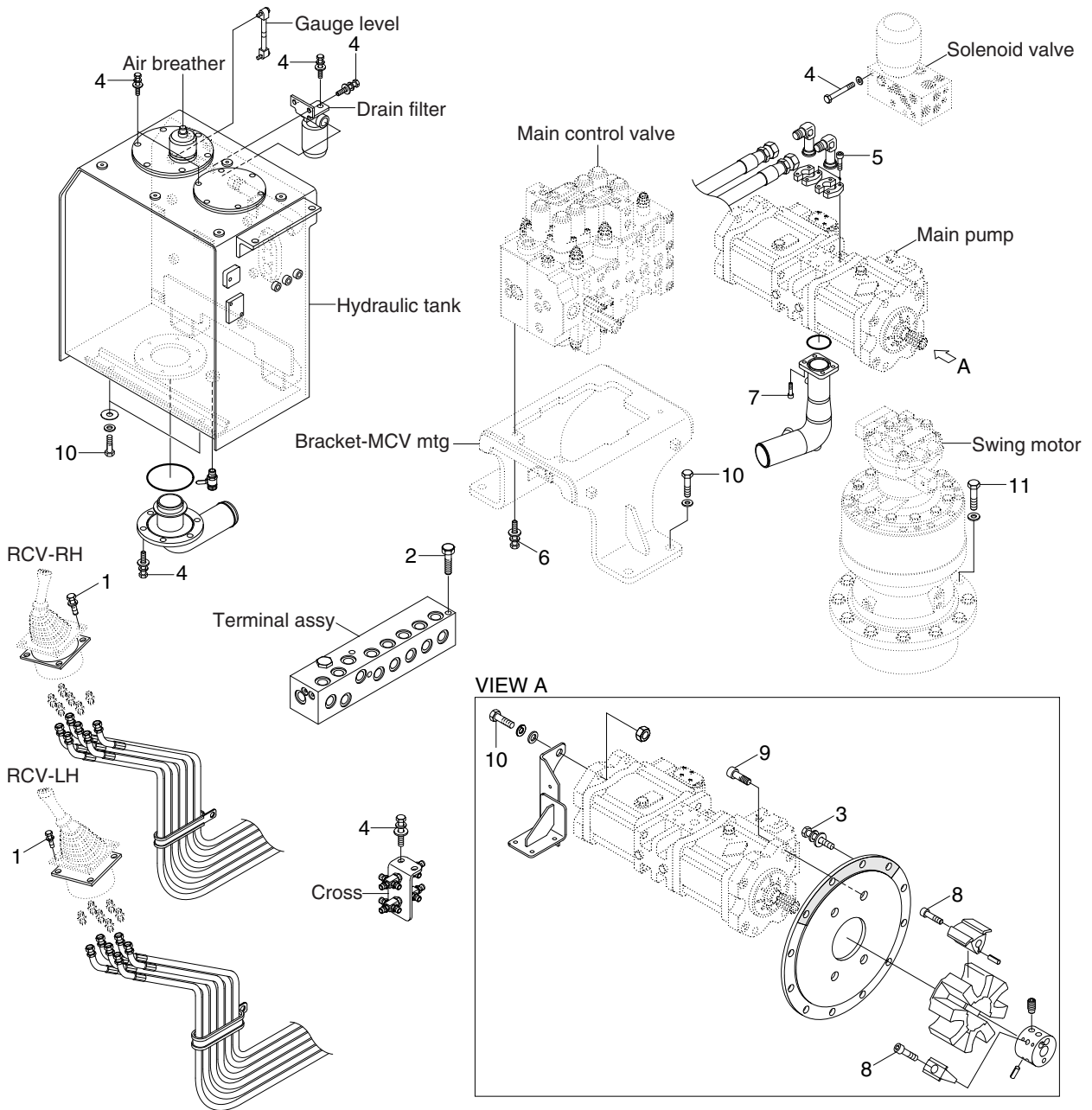

2609SB9CM05

· Tightening torque

Item	Size	kgf · m	lbf · ft
1	M6×1.0	1.05±0.2	7.6±1.45
2	M8×1.25	2.5±0.5	18.1±3.6
3	M10×1.5	4.8±0.3	34.7±2.2
4	M10×1.5	6.9±1.4	49.9±10.1
5	M10×1.5	8.27±1.7	59.8±12.3
6	M12×1.75	12.3±1.3	89.0±9.4

Item	Size	kgf · m	lbf · ft
7	M12×1.75	14.7±2.2	106±15.9
8	M18×2.5	32±1.0	231±7.2
9	M20×2.5	42±4.5	304±32.5
10	M20×2.5	57.9±8.7	419±62.9
11	M24×3.0	97.8±10	707±72
-	-	-	-

HYDRAULIC COMPONENTS MOUNTING 2

Double acting attachment piping

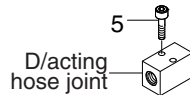
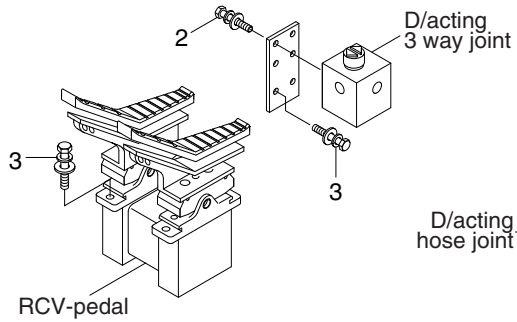
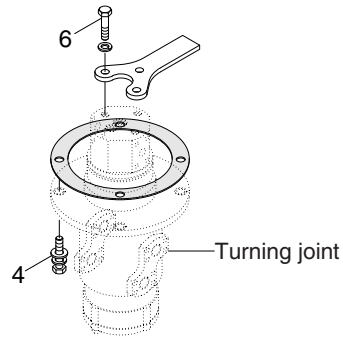
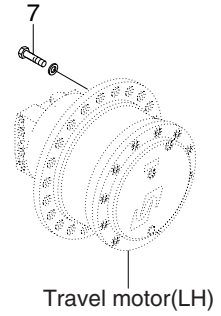
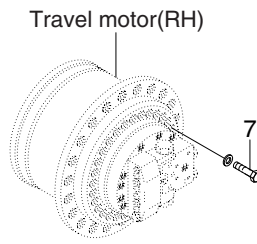
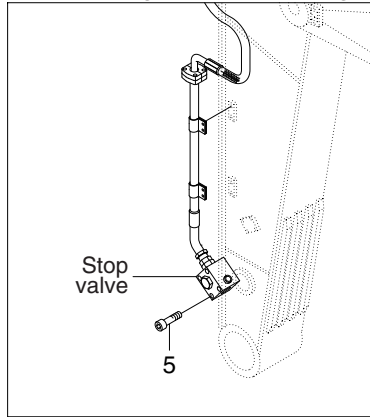

D/acting single pedal

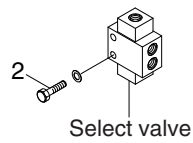
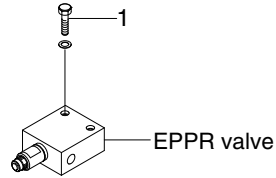
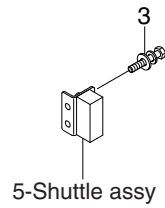
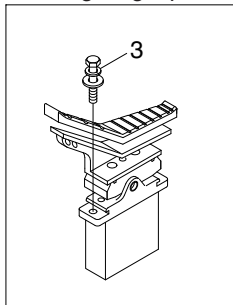

Solenoid valve

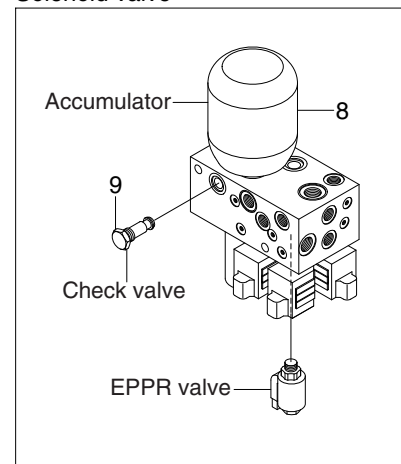

2609SB9CM06

· Tightening torque

Item	Size	kgf · m	lbf · ft
1	M 6×1.0	1.05±0.2	7.6±1.45
2	M 8×1.25	2.5±0.5	18.1±3.6
3	M10×1.5	6.9±1.4	49.9±10.1
4	M12×1.75	12.3±1.3	89.0±9.4
5	M12×1.75	14.7±2.2	106±15.9

Item	Size	kgf · m	lbf · ft
6	M14×2.0	19.6±2.9	142±20.9
7	M16×2.0	23±2.5	166±18.1
8	Accumulator	5.6±0.5	40.5±3.6
9	Check valve	2.5±0.5	18±3.6
-	-	-	-

HYDRAULIC COMPONENTS MOUNTING 3

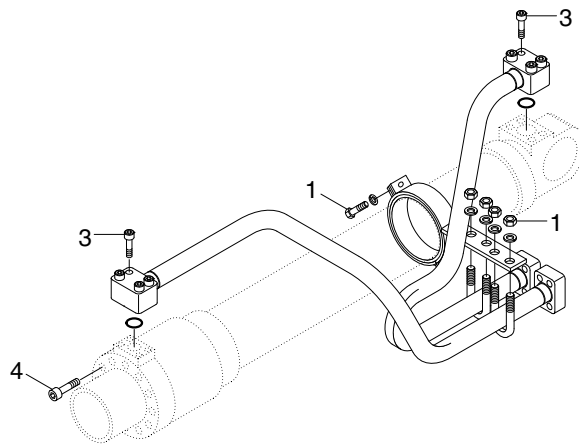

BOOM CYLINDER

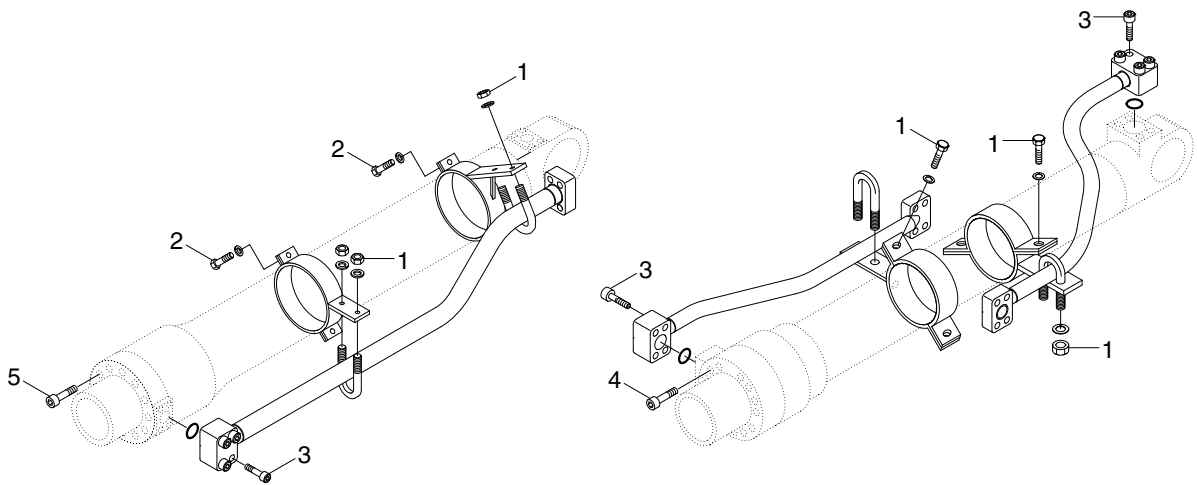

ARM CYLINDER

BUCKET CYLINDER

2609S9CM07

· Tightening torque

Item	Size	kgf · m	lbf · ft
1	M10×1.5	3.2±0.3	23.1±2.2
2	M12×1.75	5.5±0.6	39.8±4.3
3	M12×1.75	9.4±1.0	68.0±7.2

Item	Size	kgf · m	lbf · ft
4	M18×2.5	32±3.0	232±21.7
5	M20×2.5	46±5.0	333±36.2