

GROUP 7 ENGINE OVERHEAT PREVENTION SYSTEM

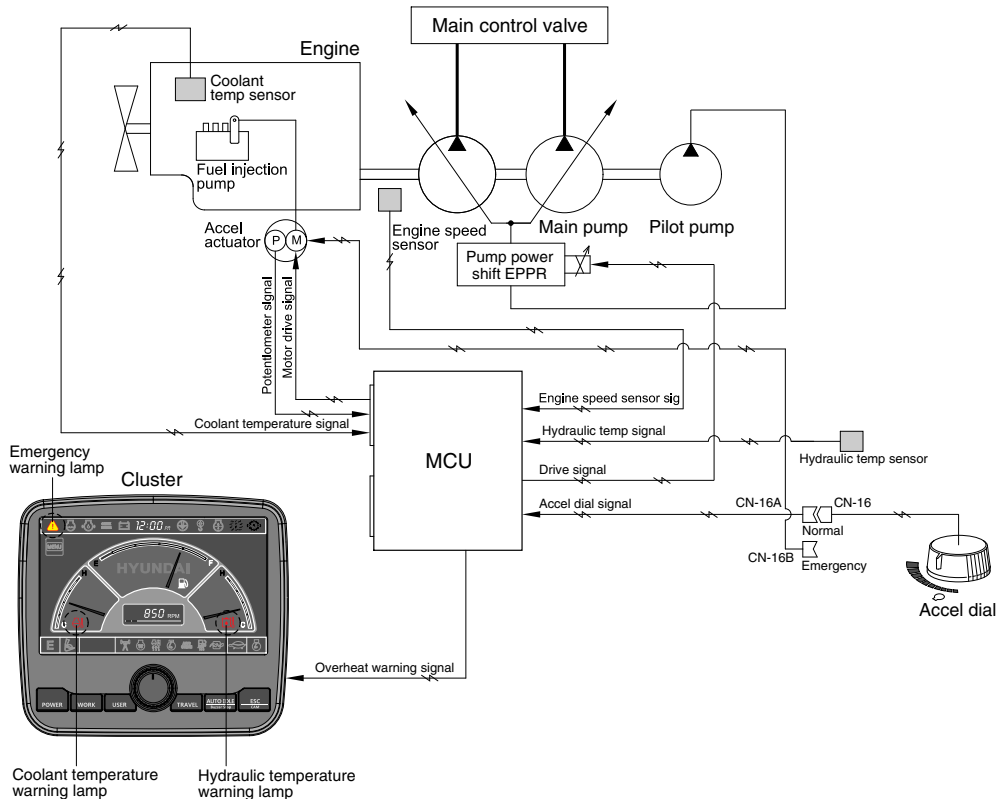

3009SH5MS09A

1. The engine coolant temperature or the hydraulic oil temperature is overheated over 100°C, the warning lamp is ON and the pump input torque or the engine speed is reduced as below logic table.

2. LOGIC TABLE

Description		Condition	Function
First step warning	Activated	- Coolant or hydraulic oil temperature : Above 100°C	- Warning lamp & buzzer : ON - Pump input torque is reduced.
	Canceled	- Coolant or hydraulic oil temperature : Less than 95°C	- Return to pre-set the pump input torque.
Second step warning	Activated	- Coolant or hydraulic oil temperature : Above 105°C	- Emergency warning lamp pops up on the center of LCD and the buzzer sounds. - Engine speed is reduced after 10 seconds.
	Canceled	- Coolant or hydraulic oil temperature : Less than 100°C	- Return to pre-set the engine speed. - Hold pump input torque on the first step warning.