

GROUP 5 SWING DEVICE (TYPE 1)

1. REMOVAL AND INSTALL OF MOTOR

1) REMOVAL

- (1) Lower the work equipment to the ground and stop the engine.
- (2) Operate the control levers and pedals several times to release the remaining pressure in the hydraulic piping.
- (3) Loosen the breather slowly to release the pressure inside the hydraulic tank.

▲ Escaping fluid under pressure can penetrate the skin causing serious injury.

※ When pipes and hoses are disconnected, the oil inside the piping will flow out, so catch it in oil pan.

- (4) Disconnect hose assembly (2).
- (5) Disconnect pilot line hoses (3, 4, 5, 6, 7, 8).
- (6) Sling the swing motor assembly (1) and remove the swing motor mounting socket bolts (9).

· Motor device weight : 66kg (146lb)

- (7) Remove the swing motor assembly.
※ When removing the swing motor assembly, check that all the piping have been disconnected.

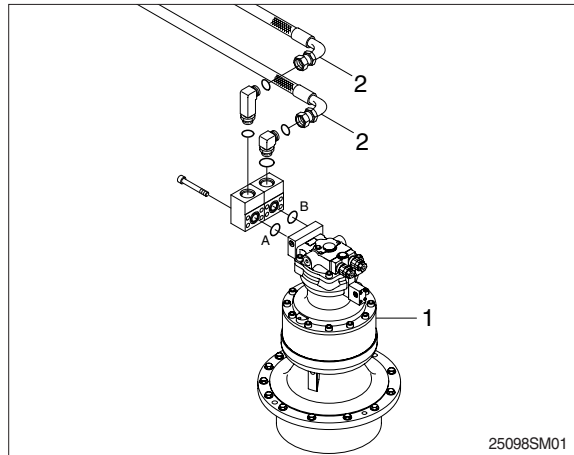

2) INSTALL

- (1) Carry out installation in the reverse order to removal.
- (2) Bleed the air from the swing motor.
 - ① Remove the air vent plug.
 - ② Pour in hydraulic oil until it overflows from the port.
 - ③ Tighten plug lightly.
 - ④ Start the engine, run at low idling and check oil come out from plug.
 - ⑤ Tighten plug fully.
- (3) Confirm the hydraulic oil level and check the hydraulic oil leak or not.

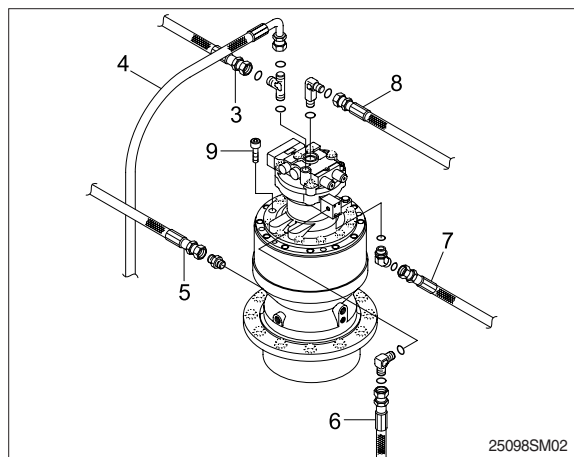

2. DISASSEMBLY AND ASSEMBLY OF SWING MOTOR

1) STRUCTURE

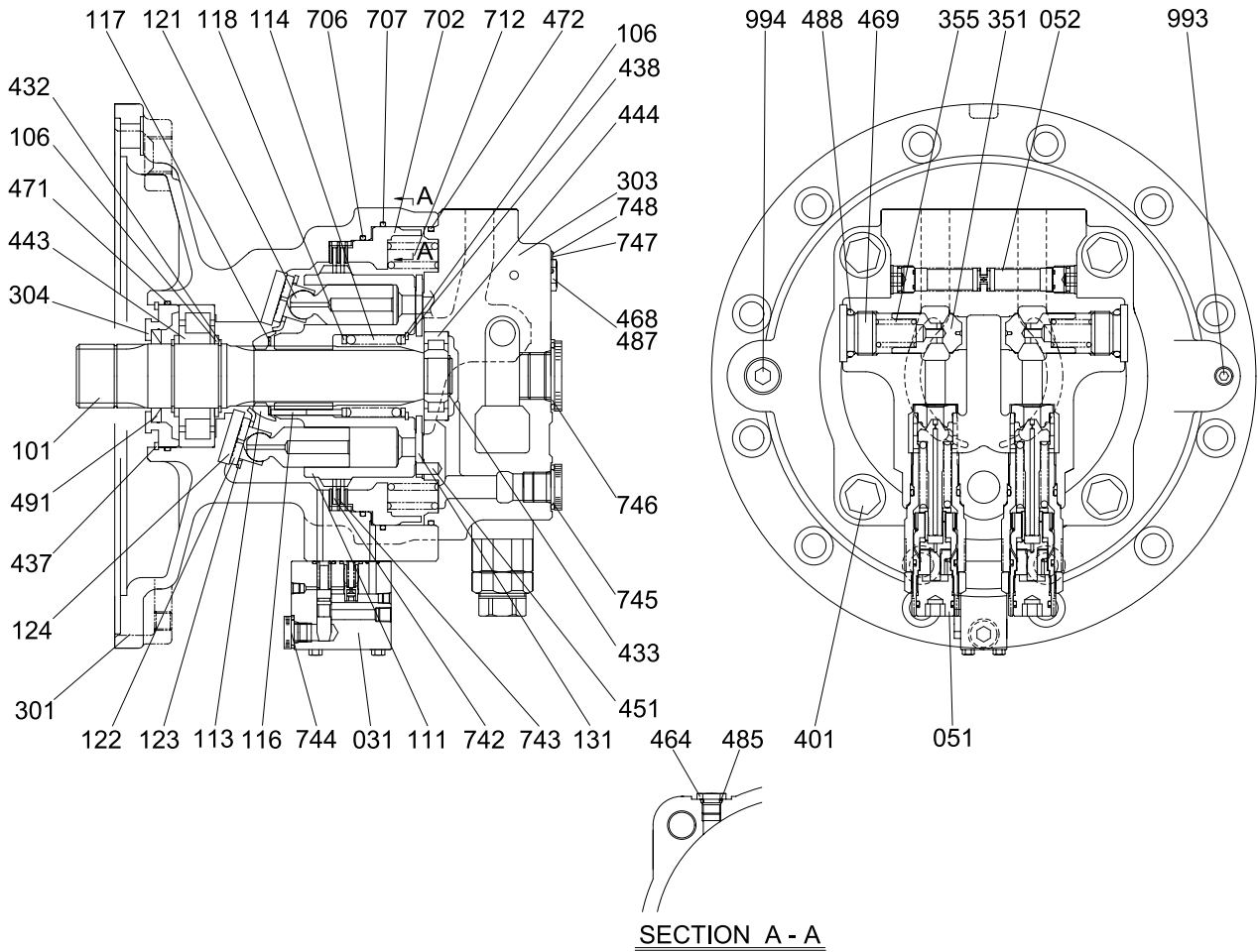

2507A2SM02

031	Time delay valve	303	Valve casing	485	O-ring
051	Relief valve	304	Front cover	487	O-ring
052	Shockless valve assy	351	Plunger	488	O-ring
101	Drive shaft	355	Spring	491	Oil seal
106	Spacer	401	Socket bolt	702	Brake piston
111	Cylinder block	432	Snap ring	706	O-ring
113	Spherical bush	433	Snap ring	707	O-ring
114	Spring	437	Snap ring	712	Brake spring
116	Push rod	438	Snap ring	742	Friction plate
117	Spacer	443	Roller bearing	743	Separate plate
118	Spacer	444	Roller bearing	744	Dust plug
121	Piston	451	Spring pin	745	Dust plug
122	Shoe	464	Plug	746	Dust plug
123	Retainer	468	Plug	747	Name plate
124	Shoe plate	469	Plug	748	Rivet screw
131	Valve plate	471	O-ring	993	Level gauge
301	Casing	472	O-ring	994	Plug

3) DISASSEMBLY

(1) Wind the wire rope at motor outside, lift up the motor, and clean the motor with cleaning oil.

After cleaning, dry with compress air.

※ Polish the dirt blocking each port with tape, couldn't enter the dirt into the motor.

(2) Draw the oil out the casing (301).

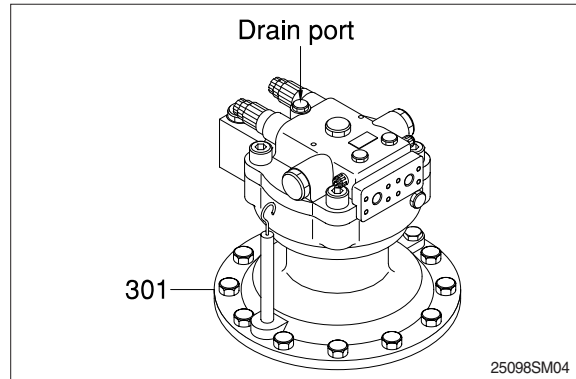

(3) Mount on a suitable table for the driven-axis (101) below.

Before disassembling make a match mark on motor casing (301) and valve casing (303).

※ Select a clean place.

Put a rubber sheet on the work bench to prevent parts from being damaged.

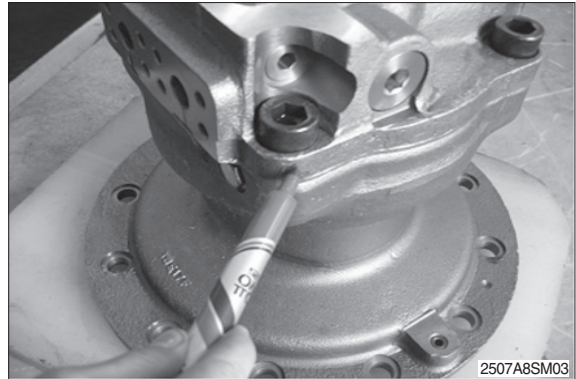

(4) Remove time delay valve (031).

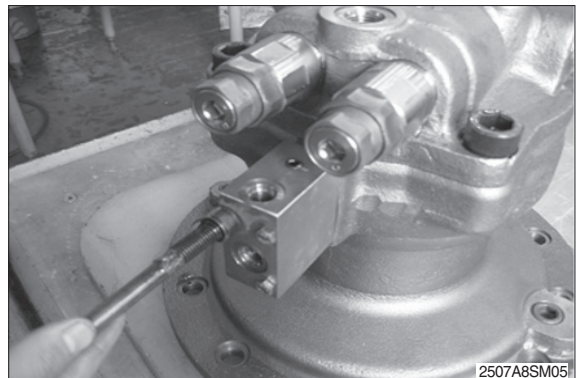

- (5) Remove relief valve (751) from valve casing (303).

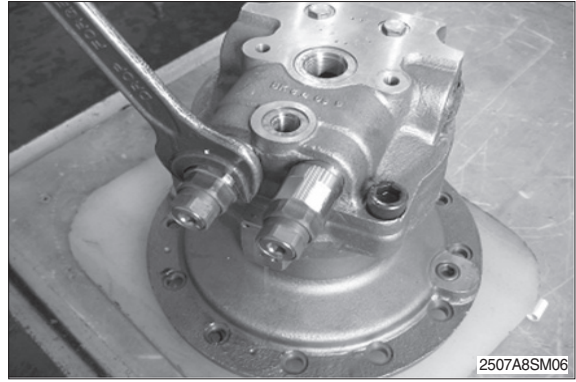

- (6) Remove Ro plug (469) and take out spring (355) and plunger (351) from valve casing.

※ Be careful not to damage the plunger seat.

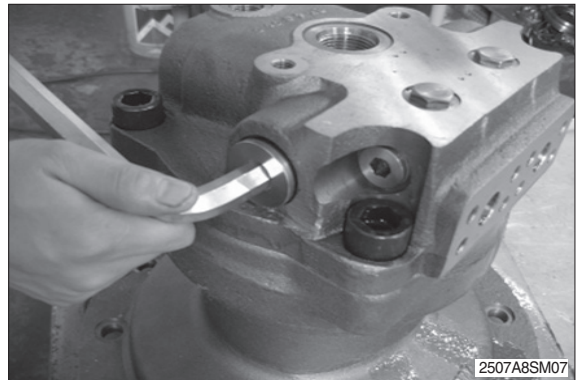

- (7) Remove hex socket bolts (401) and disassemble valve casing (303) from casing (301) (When loosening bolts, the valve casing will be raised by brake spring (712)). Remove valve plate (131) from the valve casing.

※ Be careful not to drop the valve plate from the valve casing.

(Sometimes valve plate is adhered to the cylinder)

When open the combined plane, be careful not to damage.

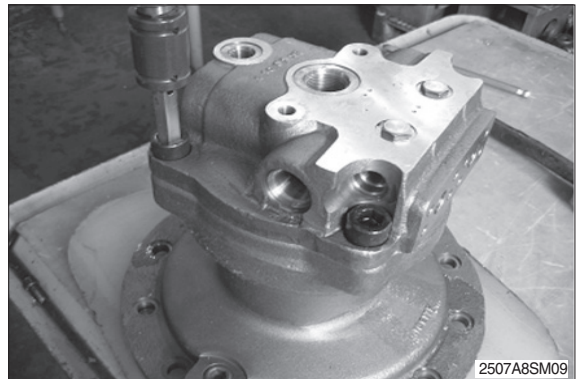

- (8) Remove brake springs (712) from the brake piston.

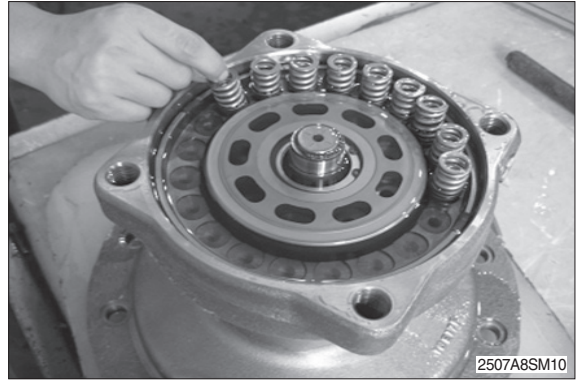

- (9) Disassemble brake piston (702) from casing (301) by using the special tool for removing the brake piston.

- ※ Lit it up straight by using the bolt hole in the brake piston.

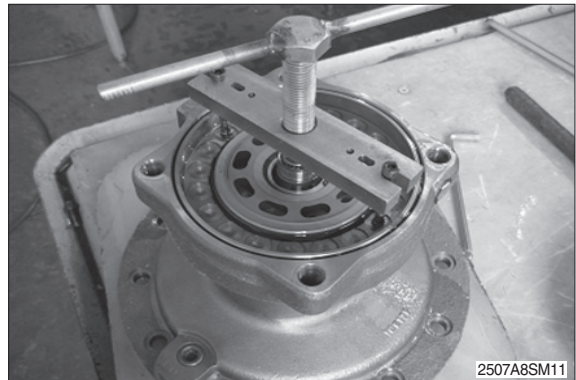

- (10) After placing the motor horizontally, take out cylinder (111) from casing(301).
Remove piston (121), retainer (123) spherical bush (113), spacer (117) and shoe plate (124).

- ※ When taking out the cylinder, be careful not to pull out push rod (116).
Be careful not to damage the sliding parts of the cylinder, spherical bush and shoe.
If difficult to remove the swash plate, disassemble it later as described in (14).

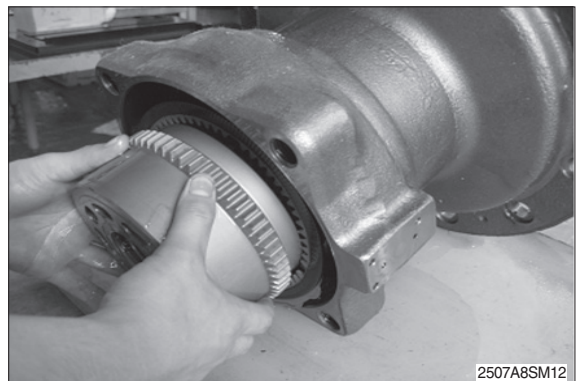

(11) Pull out friction plates (742) and separation plate (743) from casing.

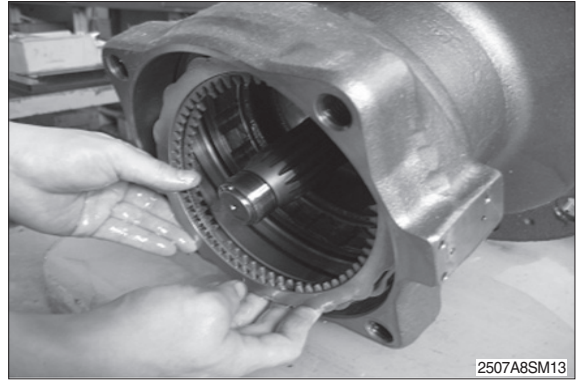

(12) Remove snap ring (437) and remove front cover (304) from casing (301).

- ※ Be careful not to damage the front cover. (The front cover can be removed with the drive shaft.)

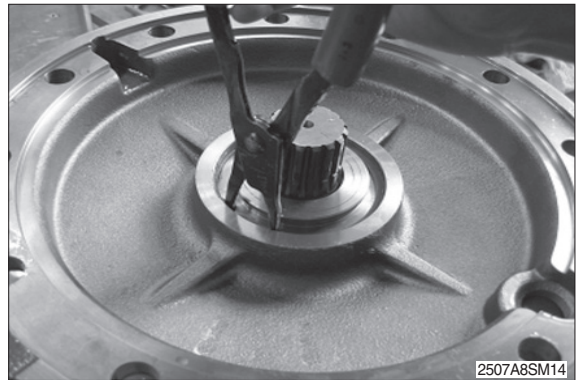

(13) Remove drive shaft (101) from casing (301) while tapping the end of the drive shaft with a plastic hammer.

- ※ Be careful not to damage the oil seal contact surface.

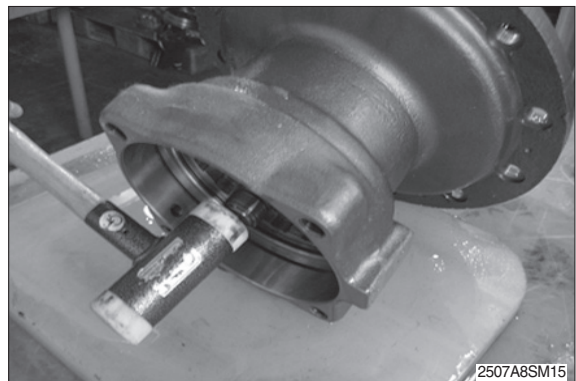

(14) Remove shoe plate (124) from the casing (301) by engaging a steel bar through the casing and the side of the housing and tapping it lightly.

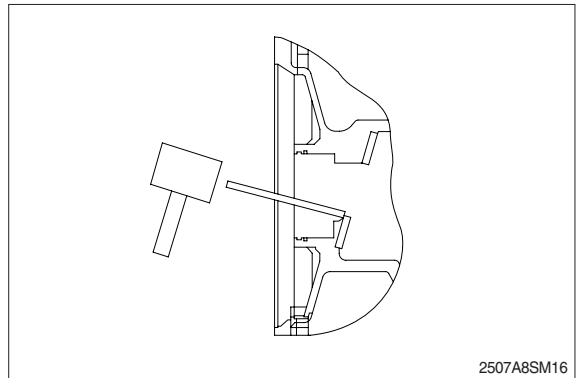

(15) Do next step if required.

- ① Remove snap ring (432) and spacer (106) from drive shaft (101) and remove roller bearing (443) with a press.

※ Strike the rod lightly and do not reuse disassembling the bearing.

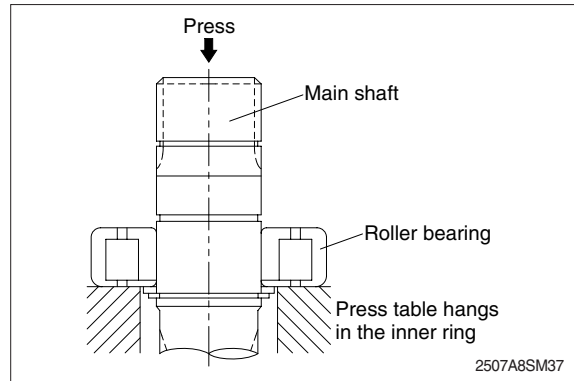

- ② Take out oil seal (304) from cover (304).

※ Do not reuse the oil seal.

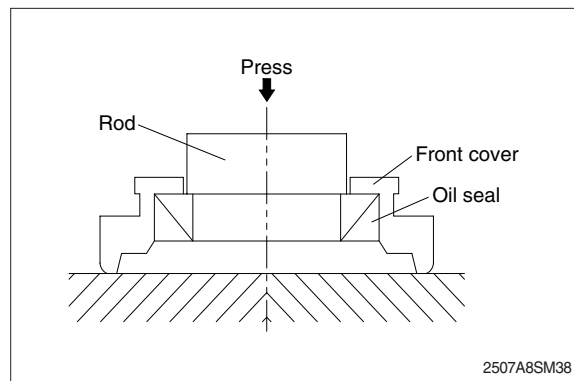

- ③ Pull out roller bearing (444) from valve casing (303) with a sliding hammer and a bearing puller.

※ Do not reuse the bearing.

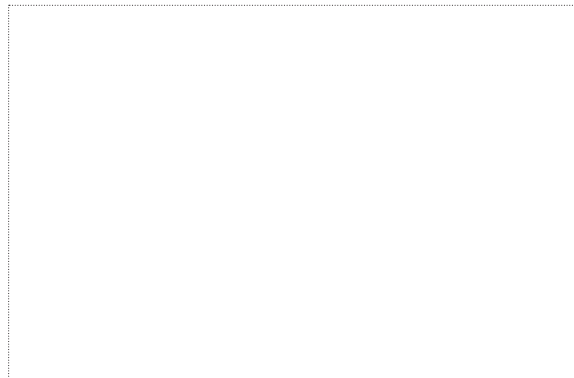

4) ASSEMBLY

Followings are caution to be specially borne in mind.

- Rework damaged parts and before assembling, prepare all parts to be replaced.
- Clean all parts and dry with compressed air.
- Coat the sliding parts and bearing with clean hydraulic oil.
- Replace O-ring and oil seal.
- For the mounting of bolts to install the various parts, please use a torque wrench, etc. and tighten the bolts with the torque shown at page 8-45.

(1) Place casing (301) on the work table with the valve casing side downward.

(2) Assembly of roller bearing ;
Mount snap ring (432) and spacer (106) to drive shaft (101) and collar of roller bearing (443) and press-fit by the heat.

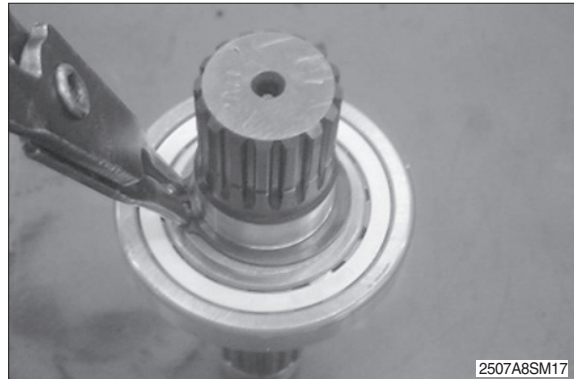

※ Pay attention to the direction of the collar.

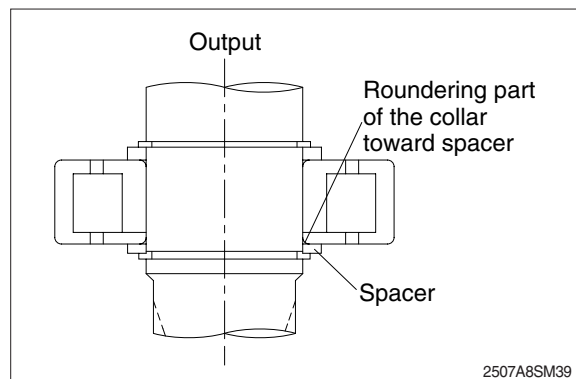

(3) Insert the drive shaft complete with bearing into casing (301). Using a brass drift tap the bearing is fully seated.

※ Impact the outside surface outer loop uniformly till stop at casing section.

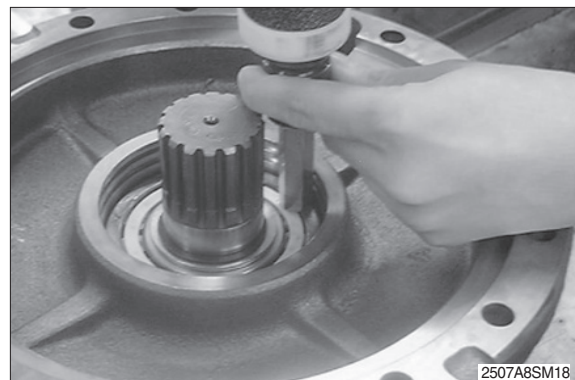

(4) In case of the oil seal disassembling press-fit oil seal (491) to front cover (304) by using a jig.

- ※ Be careful to note the direction of the oil seal.
Press-fit until fully seated.

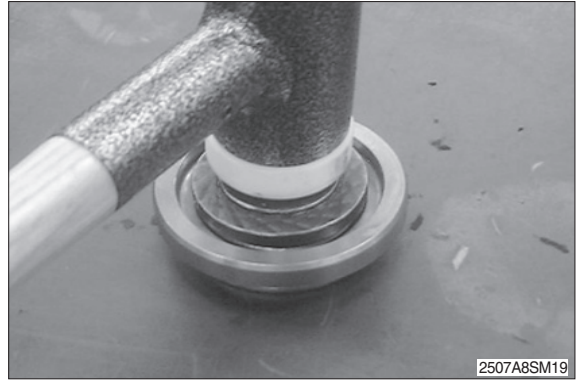

(5) Mount O-ring (471) to casing (301).

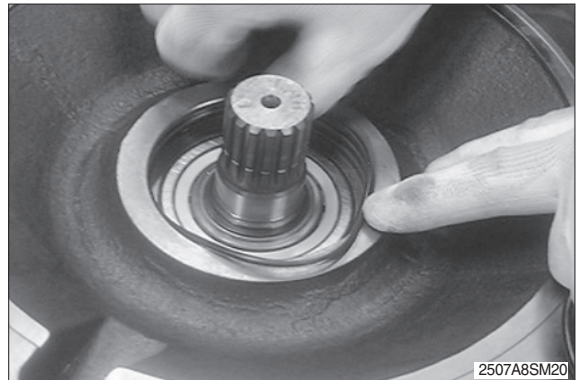

(6) Assemble front cover (304) to casing (301) while tapping it lightly with a plastic hammer.

- ※ Coat the lip of the oil seal with grease and tape the shaft spline.
Tap evenly.

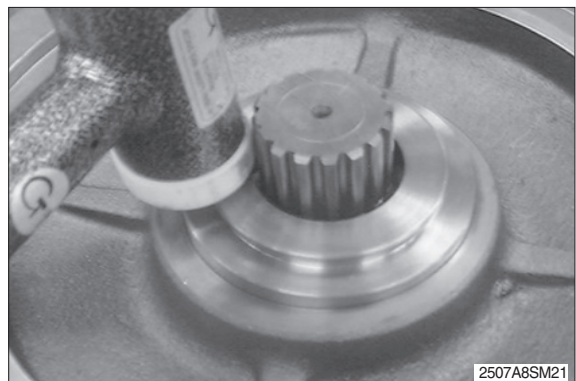

(7) Mount locking snap ring (437) to casing (301) by using the plier.



(8) Insert shoe plate (124)

- ※ Insert it with the larger chambered side of the shoe plate toward the casing.
Coat lightly with grease.

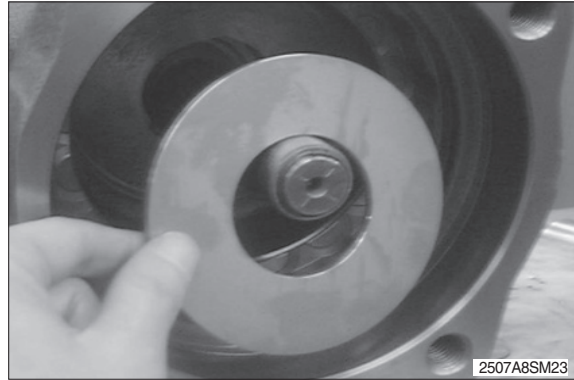

(9) Insert push rods (116) and spacer (117) to cylinder (111) and place spherical bush (113) to the cylinder.

- ※ Be careful not to damage the sliding surface of the cylinder insert 2 push rods into each hole.

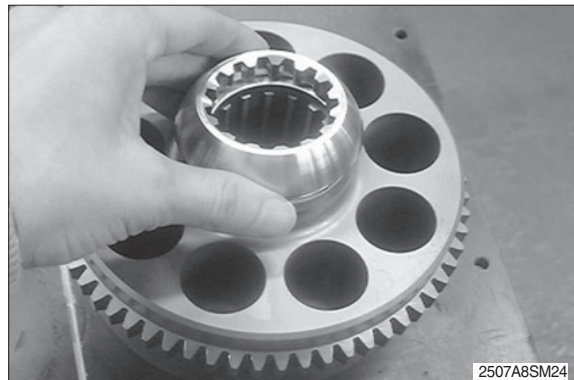

(10) Fit piston sub assembly unit (121, 122) to retainer.

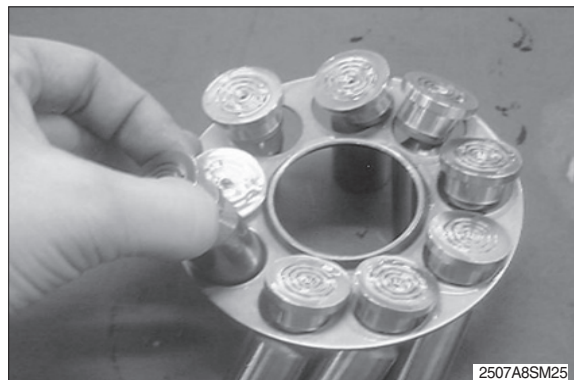

(11) Assemble the retainer with the piston sub assembly (120, 222) unit to the cylinder block (111).

- ※ Insert it to drive shaft (101) aligning the spline.

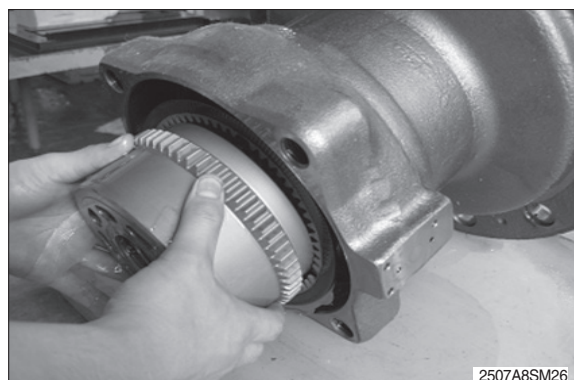

- (12) Place casing (301) with front cover (304) downward and assemble separation plate 3 EA (743) and friction plate 2 EA (742) in sequence.



- ※ Align 4 tangs to the notches as shown.
Cut the jaw and assemble that plate like right picture.

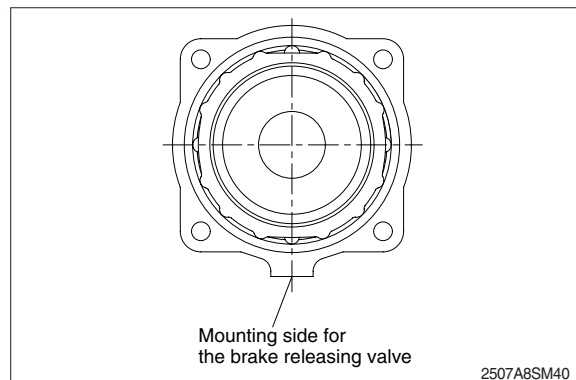

- (13) Mount O-ring (706, 707) to casing (301).

- ※ Coat the O-ring with grease.

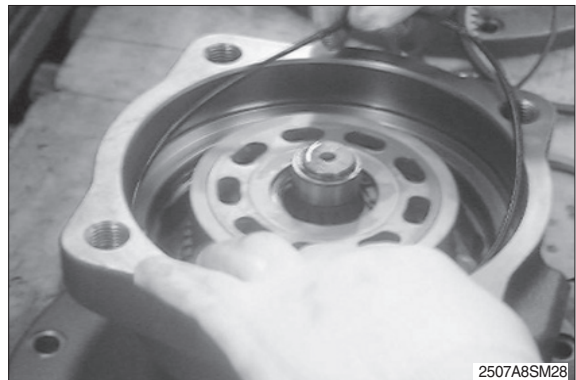

- (14) Assemble brake piston (702) to casing (301).

- ※ Place 4 notches of the brake piston as shown next page.



- ※ The piston is difficult to assemble because of the restriction of the O-ring; screw in two M8 bolts on the brake piston and tap them gently.

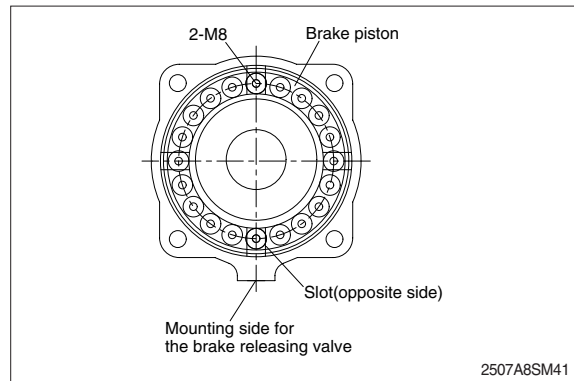

- (15) Assemble brake springs (712) into brake piston (702).
- ※ Confirm the springs are fitted to the brake piston completely.

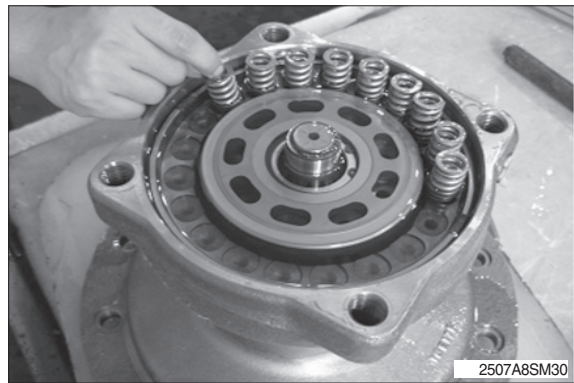

- (16) Assemble of roller bearing (444).
Insert it to valve casing (303) while tapping it lightly.
- ※ Tap evenly on the outer diameter of the outer race with a brass drift until it completely stops.
Do not use a steel punch or bar on the bearing since it can chip or crack the race.

- (17) Assemble valve plate (131) to valve casing(303) and fit O-ring (472).

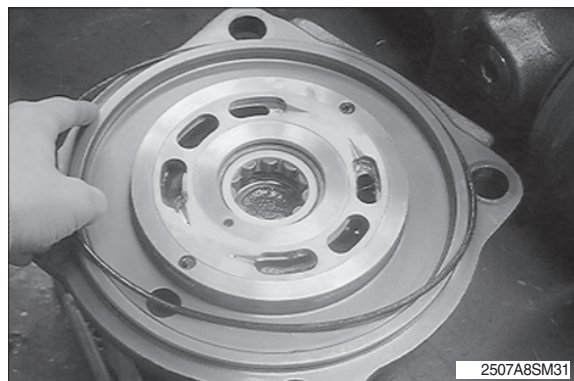

- ※ Be careful to note the direction of the valve plate.
- Mount the valve plate with its round part toward the opposite side of the flange.
- Coat lightly with grease.

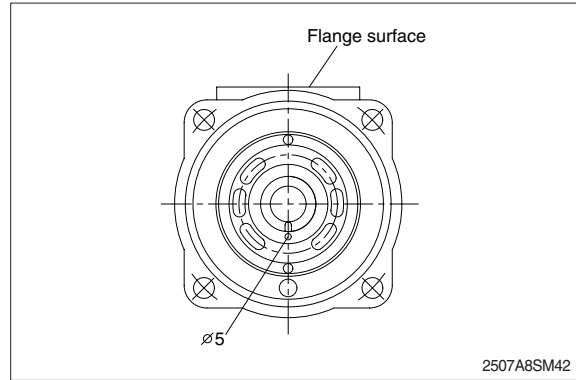

- (18) Mount valve casing (303) to casing (301) and tighten hex socket bolts (401) to specification.

- ※ Be careful to note the mounting direction of the valve plate (Refer to the drawing). Be careful not to drop the valve plate or let the brake springs pop out tighten the bolts evenly.

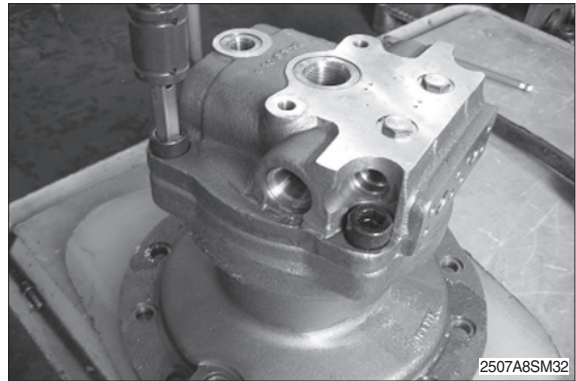

- (19) Install plunger (351) and spring (355) to valve casing and tighten Ro plug (469) with O-ring (488)

- ※ Confirm the smooth movement of the plunger before installing the plug.



- (20) Assemble relief valve with back-up ring (162) and O-ring (161) to valve casing (303)

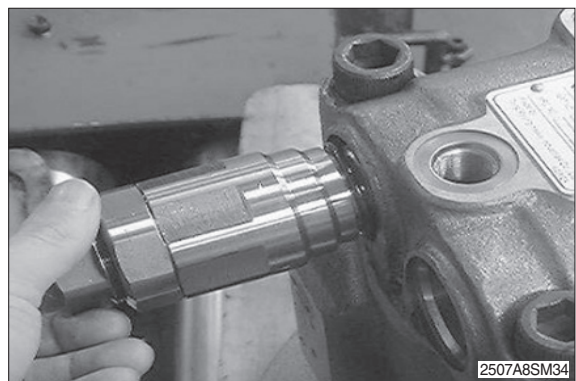

- (21) Tighten plug (468) with O-ring (487) to valve casing (303).
Tighten plug (464) with O-ring (485) to casing (301)

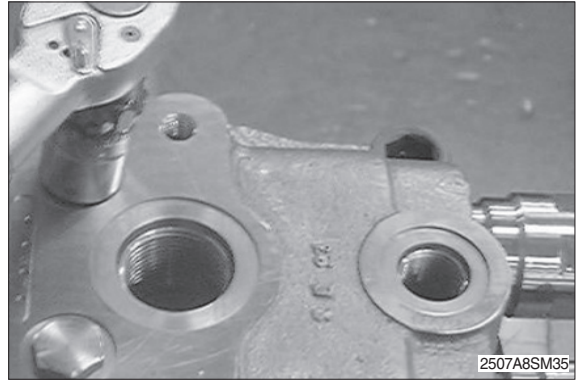

- (22) Assemble time delay valve (761) to casing (301) and tightening the hex socket bolts to specified torque.

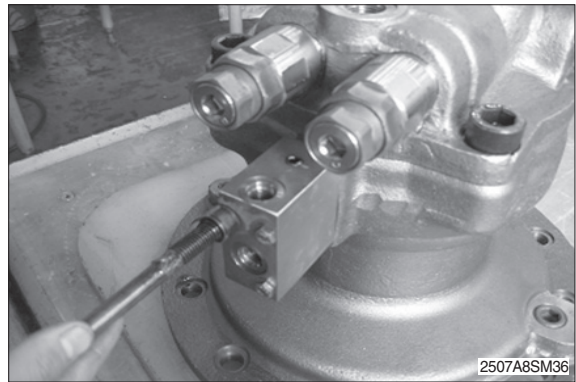

3. REMOVAL AND INSTALL OF REDUCTION GEAR

1) REMOVAL

- (1) Remove the swing motor assembly.
For details, see removal of swing motor assembly.
- (2) Sling reduction gear assembly (1) and remove mounting bolts (2).
- (3) Remove the reduction gear assembly.
 - Reduction gear device weight :
279 kg(615 lb)



2) INSTALL

- (1) Carry out installation in the reverse order to removal.
 - Tightening torque : 97.8 ± 10 kgf · m
(707 ± 72.3 lbf · ft)

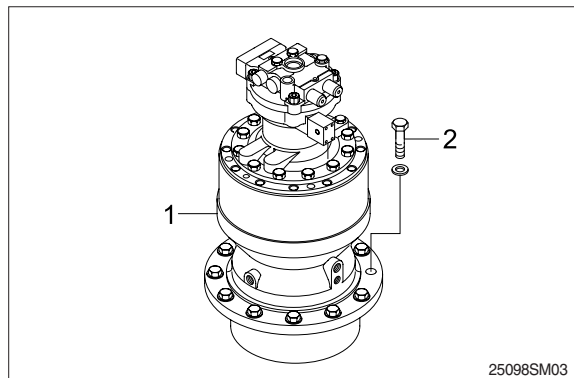

4. DISASSEMBLY AND ASSEMBLY OF REDUCTION GEAR

1) REDUCTION GEAR

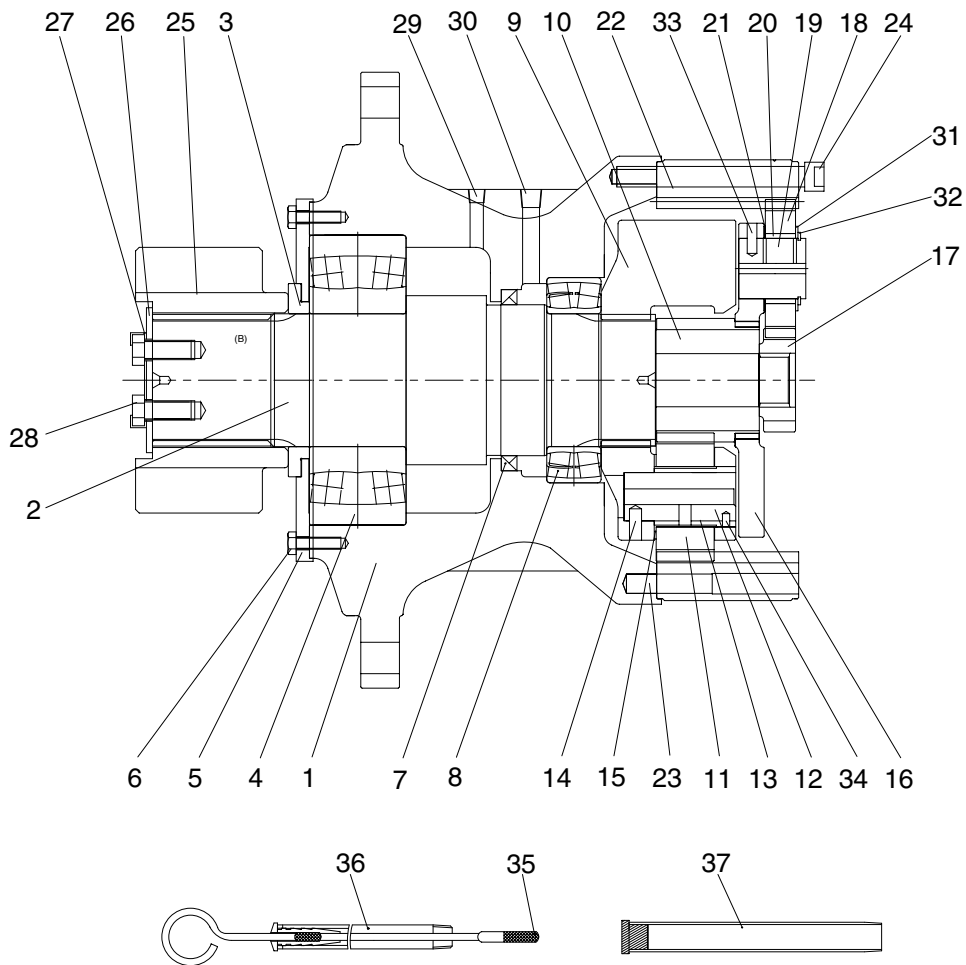

2507A2SM03

1	Casing	14	Spring pin	27	Lock washer
2	Drive shaft	15	Thrust washer	28	Hexagon bolt
3	Spacer	16	Carrier 1	29	Plug
4	Roller bearing	17	Sun gear 1	30	Plug
5	Cover plate	18	Planet gear 1	31	Side plate 2
6	Hexagon bolt	19	Pin 1	32	Stop ring
7	Oil seal	20	Needle cage	33	Spring pin
8	Roller bearing	21	Side plate 1	34	Spring pin
9	Carrier 2	22	Ring gear	35	Gage bar
10	Sun gear 2	23	Knock pin	36	Gage pipe
11	Planet gear 2	24	Socket bolt	37	Air breather assy
12	Pin 2	25	Pinion gear		
13	Bushing 2	26	Lock plate		

2) DISASSEMBLY

(1) SWING REDUCTION GEAR

- ① Remove plug (29, 30) and drain out gear oil.



- ② Loosen the socket bolts (24) to separate swing motor from reduction gear.



- ③ Move out No.1 sun gear (17) and No.1 carrier sub assy by using jig.



- ④ Full out No.2 sun gear (10).

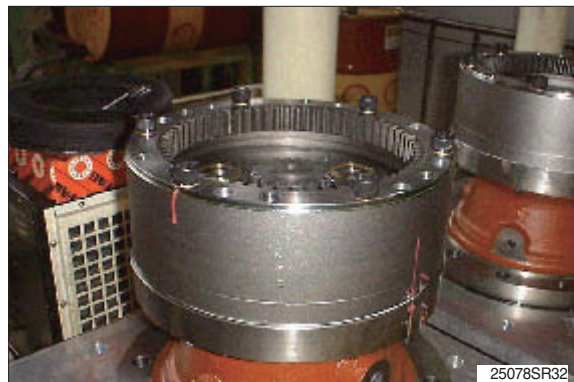

- ⑤ Full out No.2 carrier sub assy by using jig and crane.
- ※ Pay attention to ensure gear is not damaged during disassembling.

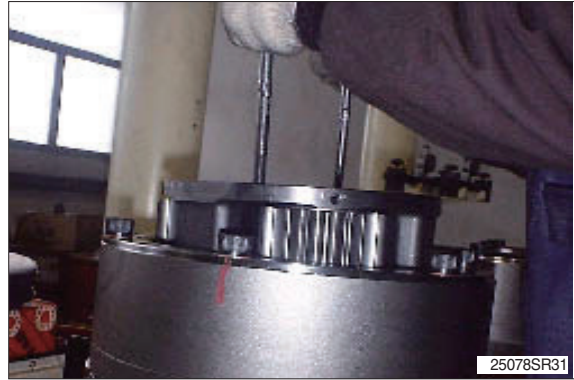

- ⑥ Move out ring gear by the removal groove between ring gear (22) and casing (1) by using removal jig.



- ⑦ Full out knock pin (23).
- ※ Do not need to remove the knock pin if it is not worn or damaged.



- ⑧ Put it on the working table with drive shaft up.

- ⑨ Remove lock washer (27) by removal jig and loosen hex bolt (28) with fixing pinion gear (25) and thereafter plate lock (26) & pinion gear (25).



- ⑩ Loosen hex bolt (6) and remove spacer (3) and cover plate by screwing a removal bolt into tap hole on the cover plate (5).



- ⑪ Dismantle drive shaft by using jig
- ※ Removed oil seal should not be reused. Replace new oil seal when assembling.



(2) NO.1 CARRIER SUB ASSY

- ① Remove stop ring (32) and dismantle No.2 side plate (31) and No.1 planet gear (18).



- ② Dismantle needle cage (20) and No.1 side plate (21).

- ※ Do not need to dismantle No.1 pin, No.1 carrier and spring pin, when they have no problems.
- ※ Be sure to make a marking on the pin of each planet gear to ensure them to be placed in the same locations when assembling.

When need to dismantle pin. Hammer the section end of pin to pull out.



(3) NO.2 CARRIER SUB ASSY

- ① Remove spring pin (14) by hammering in a key to the opposite side of the No.2 pin.



② Full out No.2 pin assy

- ※ Do not reuse both the No.2 pin assy and spring pin.



(4) SHAFT ASSY

① Press drive shaft (2) by using jig to remove roller bearing.

- ※ Do not need to disassemble if it has no special problems.



3) ASSEMBLY

(1) NO.1 CARRIER SUB ASSY

① Place the No.1 carrier (16) horizontally on the work table. Fit the No.1 pin (19) into the hole of No.1 carrier (16) by hydraulic pressing machine.

- ※ Be careful to direct the pin (19) perpendicularly to the carrier (16) when pressing.



② Install the No.1 side plate (21) and needle cage (20) thereafter.



- ③ Put No.1 planet gear (18) and No.2 side plate (31) together and install a stop ring (32) by using assembling.



- ④ Insert spring pin (33) into the carrier sub-assembly by using jig and hammer.
- ※ Take care of planet gear1 (18) when assembling spring pin (33).

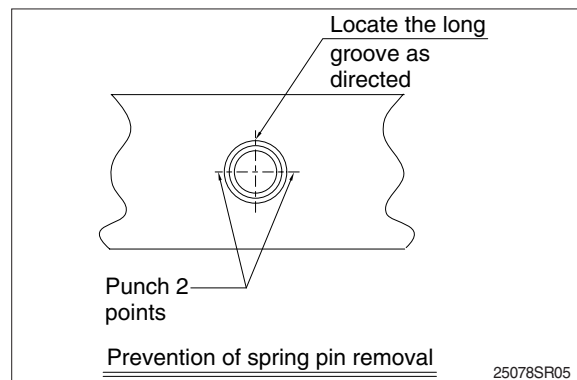

(2) ASSEMBLY-NO.2 CARRIER

- ① Place the thrust washer (15) on the No.2 carrier (9), meeting it with pin hole location. Be sure to check that the carrier (9) is not turned up side down when putting the washer (15).



- ② Place No.2 planet gear (11) onto the right location of the carrier (9).



- ③ Assemble the planet gears (11) and carrier (9) by inserting the pin assembly (12) using rubber hammer. Pay special attention to locate the spring pin hole to meet with the hole of the carrier (9).

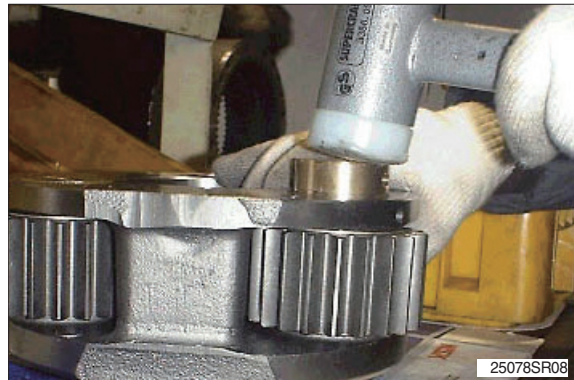

- ④ Insert spring pin (14) by using fixture and hammer.
- ※ Take care of planet gears (11) when hammering the pin (12).

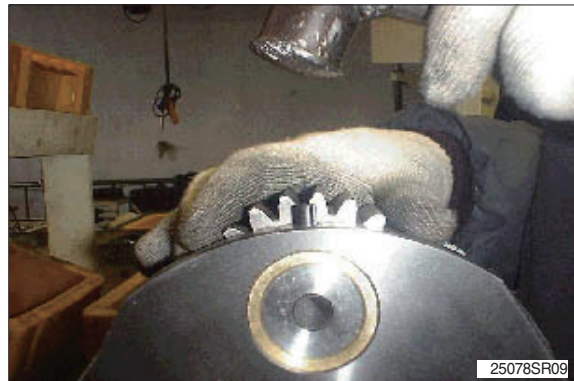

- ⑤ After complete assembly, check if it revolves without problem when rotate the planet gears (11) by hand.
- ※ When problems found in revolution, disassemble it in reverse course and assemble again. Be sure to use new spring pin (14) when re-assembling.

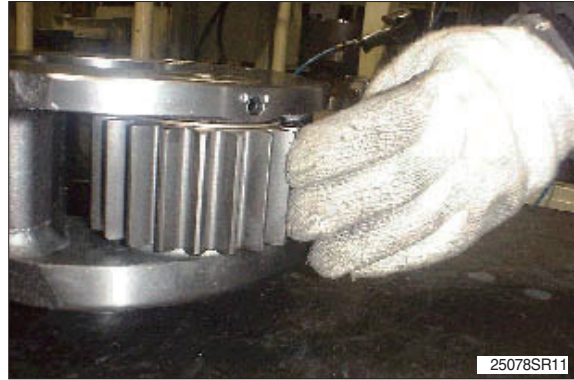

(3) SHAFT ASSY

- ① Heat roller bearing (4) with bearing heater up to about 80~100°C.
- ※ Be sure to keep the suggested heating temperature. Over heating may cause deformation.



- ② Demagnetize roller bearing (4) using demagnetizing machine.
- ※ Use special care to handle the bearing as it is very hot.



- ③ Place drive shaft (2) with positioning 2 tap holes upside.
- ④ Put bearing into drive shaft (2).
- ※ Be sure to prevent any contamination on the assembling surface during the install. Be sure to check by eye the surface of roller bearing (4) is completely contacting to the mating surface of the drive shaft (2).



- ⑤ Turn the drive shaft (2) to have the 2 tap hole side down and inject grease oil into roller bearing (4).
Recommended amount of grease is 1.4 kg (3.1pound).

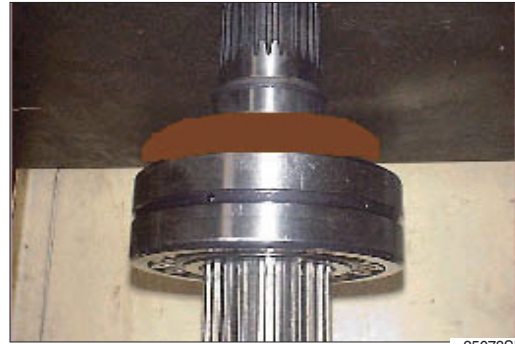

25078SR15

(4) CASE SUB ASSY

- ① Place the case (1) on the reversing machine, having the flange side of the case up.
- ② Tighten lifting bolts into the 2 Tap holes (M16) of shaft (2) and install shaft assembly (2) into case using crane.
- ※ Be sure to clean the case before install, using washing machine with the temperature of 80 °C (176 °F).
Do not install shaft assembly by force.



25078SR16

- ③ Assemble cover plate (5) and thereafter spacer (3).
- ※ Use jig when assembling spacer to be seated completely on surface.
Spread grease on the inner part of spacer.



25078SR17

- ④ Assemble cover plate (5) with case (1) after spreading loctite 262 and tighten hex bolt(M10) (6).



25078SR18

- ※ Be sure to check by eye the oil seal (7) is seated completely after being installed.

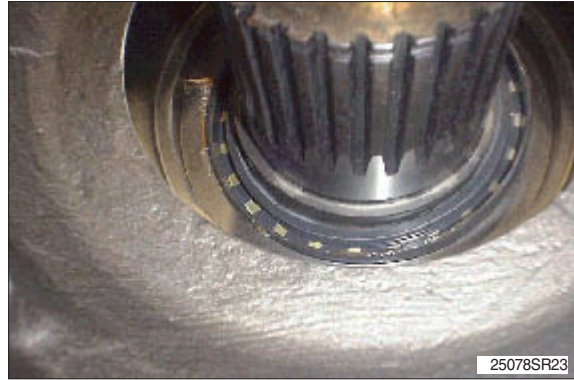

- ⑨ Spread loctite 609 on the outside ring of roller bearing (8) and insert the bearing (8) by using a pressing jig.



- ⑩ Clean the assembling surface of case and spread packing liquid (TH1105).

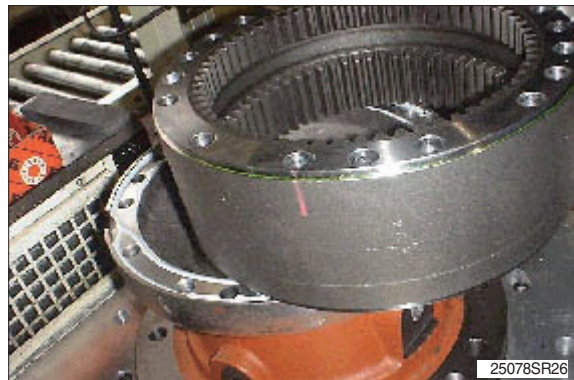

- ⑪ Place ring gear (22) on the case by matching knock pin hole.
- ⑫ Insert 4 knock pins (23) by using jig.
- ※ Be sure to check the hole location of oil gage before inserting.



- ⑬ Assemble ring gear with case by screwing socket bolt (M16) (24). Spread loctite 262 on socket bolt (24) when installing.



- ⑭ Install drain plug (29,30) after winding sealing tape.



- ※ Leak test
The successful assembly should have no air leakage when applied by 2 kgf/cm² of compressed air for about 3 minutes after being air sealed.

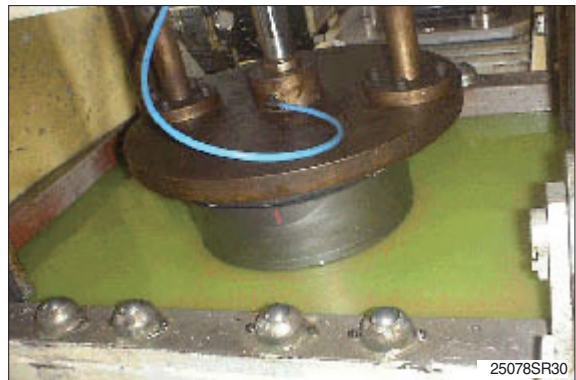

(5) SWING REDUCTION GEAR

- ① Mount No.2 carrier assembly in the case sub assembly and install bolts into 2 tap holes (M8).
- ※ Turn the carrier slowly by hand to adjust the matching holes when assembling.

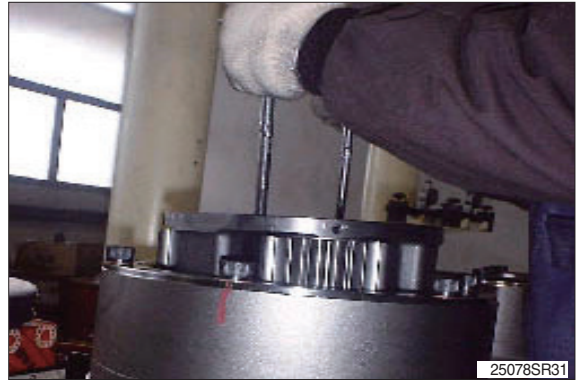

- ② Install No.2 sun gear (10).
- ※ Be sure to check the direction of sun gear (10) when assembling.



- ③ Mount No.1 carrier assembly in the case sub assembly and install bolts into 2 tap holes (M8).
- ※ Turn the carrier slowly by hand to adjust the catching holes when assembling.



- ④ Assemble No.1 sun gear (17).



GROUP 5 SWING DEVICE (TYPE 2)

1. REMOVAL AND INSTALL OF MOTOR

1) REMOVAL

(1) Lower the work equipment to the ground and stop the engine.

(2) Loosen the breather slowly to release the pressure inside the hydraulic tank.

▲ Escaping fluid under pressure can penetrate the skin causing serious injury.

※ When pipes and hoses are disconnected, the oil inside the piping will flow out, so catch it in oil pan.

(3) Disconnect pipe assy (2).

(4) Disconnect pilot line hoses (3, 4, 5, 6, 7, 8).

(5) Sling the swing motor assembly (1) and remove the swing motor mounting bolts (9).

· Motor device weight : 65 kg (140 lb)

(6) Remove the swing motor assembly.

※ When removing the swing motor assembly, check that all the piping have been disconnected.

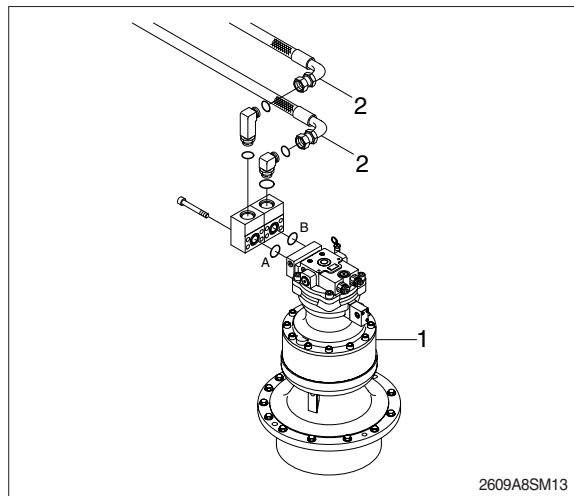

2) INSTALL

(1) Carry out installation in the reverse order to removal.

(2) Bleed the air from the swing motor.

① Remove the air vent plug.

② Pour in hydraulic oil until it over flows from the port.

③ Tighten plug lightly.

④ Start the engine, run at low idling, and check oil come out from plug.

⑤ Tighten plug fully.

(3) Confirmed the hydraulic oil level and check the hydraulic oil leak or not.

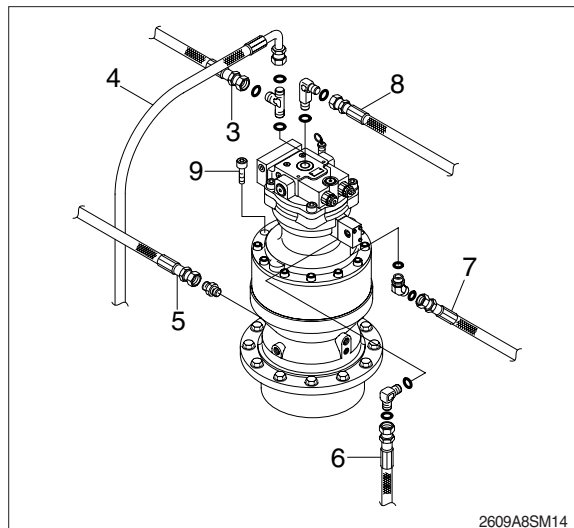

2. SWING MOTOR

1) STRUCTURE

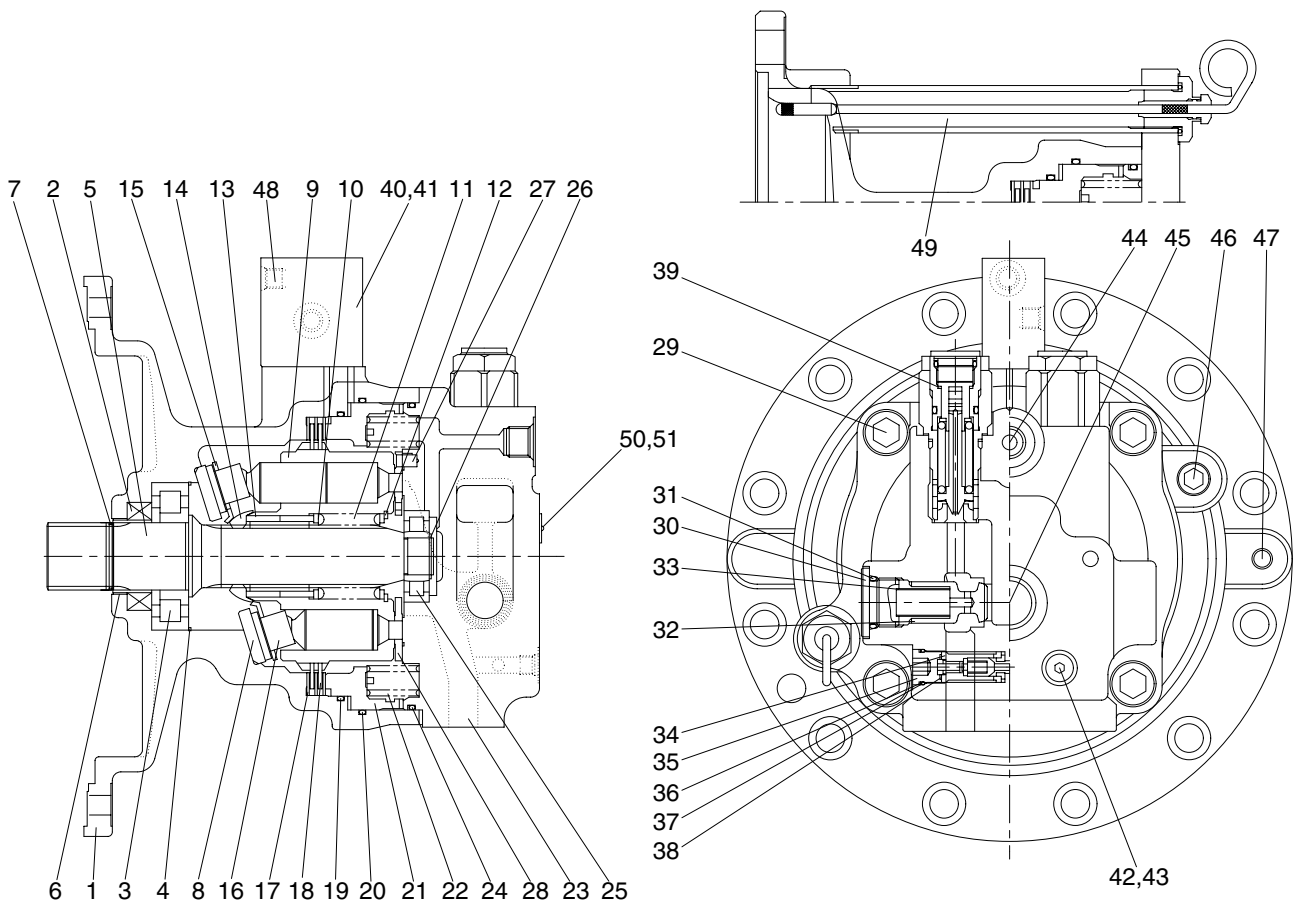

2609A2SM02

1	Body	18	Friction plate	35	Plug
2	Oil seal	19	O-ring	36	Back up ring
3	Roller bearing	20	O-ring	37	O-ring
4	Snap ring	21	Brake piston	38	O-ring
5	Shaft	22	Spring	39	Relief valve assy
6	Bushing	23	Rear cover	40	Time delay valve assy
7	Stop ring	24	O-ring	41	Wrench bolt
8	Shoe plate	25	Roller bearing	42	Plug
9	Cylinder block	26	Snap ring	43	O-ring
10	Spring seat	27	Pin	44	Plug
11	Cylinder spring	28	Valve plate	45	Plug
12	Snap ring	29	Wrench bolt	46	Plug
13	Pin	30	Plug	47	Plug
14	Ball guide	31	O-ring	48	Plug
15	Set plate	32	Check	49	Level gauge
16	Piston	33	Spring	50	Name plate
17	Plate	34	Reverse prevention valve	51	Rivet

2) TOOL AND TIGHTENING TORQUE

(1) Tools

Tool	Size B	Name of parts applied
Hexagonal L-wrench	5	Wrench bolt (41)
	6	Plug (42)
	10	Reverse prevention valve (34)
	17	Wrench bolt (29), Plug (30)
Socket wrench/Spanner	36	Relief valve assy (39)
Snap-ring plier (for holes, axis)		Snap ring (4, 12)
Hammer		Pin (27)
Torque wrench		Relief valve assy (39), Body (1) & Rear cover (23), Removing wrench bolt (29, 41) (Tighten torque) · 1 ~ 4.5 kgf·m · 4 ~ 18 kgf·m · 12 ~ 48 kgf·m
Jig for oil seal assembly		Oil seal (2)
Heating tool for bearing		Roller bearing (3)
Brake piston removing tool		See following page

(2) Tightening torque

No.	Part name	Bolt size	Dimension (B)	Torque	
				kgf·m	lbf·ft
39	Relief valve	M33	46	24	173.6
42	Plug	PF1/4	6	4	28.9
41	Wrench bolt	M6	5	1.2	8.7
29	Wrench bolt	M20	17	42	303.8
34	Reverse preventing valve	M22	10	10	72.3

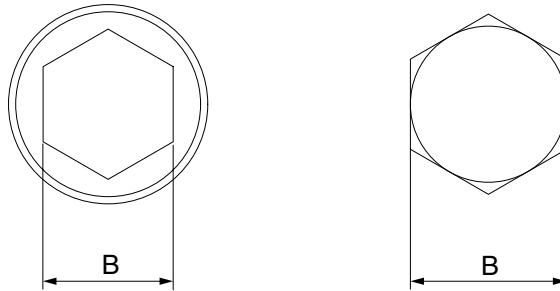

300H8SM04

(3) Brake piston removal tool

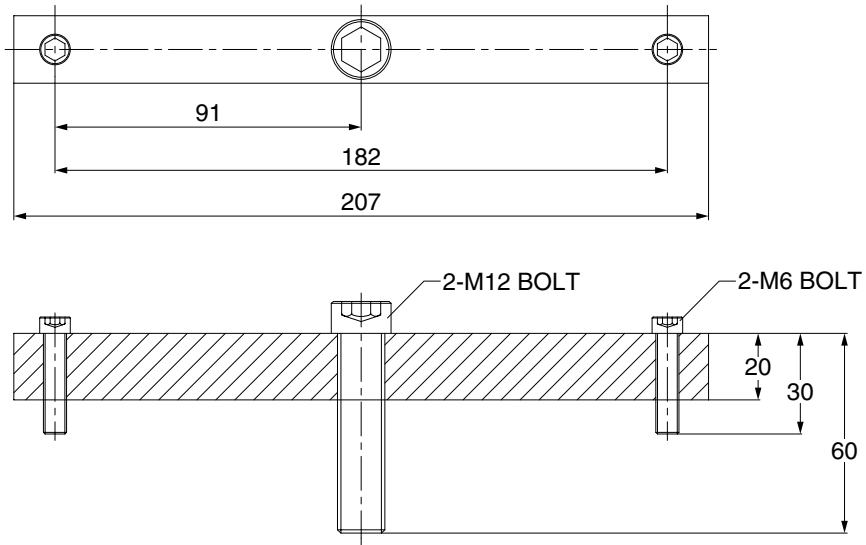

300H8SM03

2) DISASSEMBLY

- (1) Set up the motor assy on the workbench for disassembly

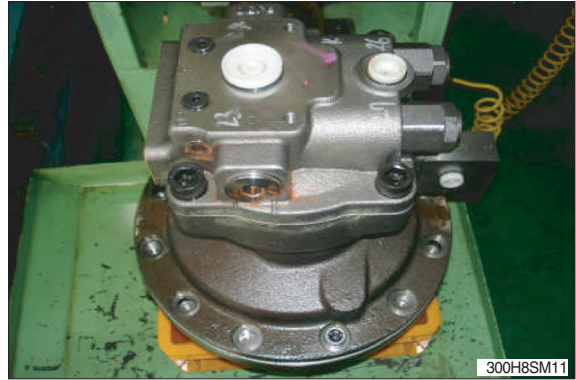

- (2) Draw the line to body (1) and rear cover (23).

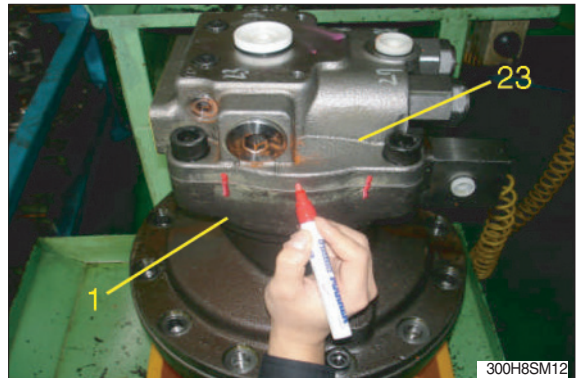

- (3) Use the L-wrench to disassemble the time delay valve (40) from the body (1).
Release wrench bolt (41, 3EA).

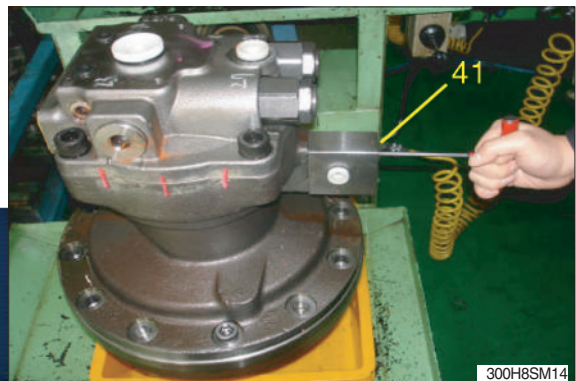
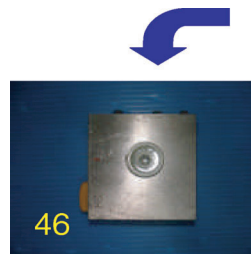

- (4) Disassemble the relief valve (39) from the rear cover (23).

- ※ Do not disassemble the relief valve (39) never.
This will change the pressure setting of the valve.

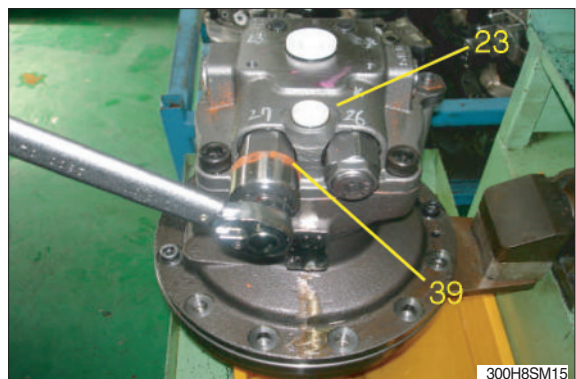

- (5) Disassemble the check valve plug (30) from the rear cover (25).

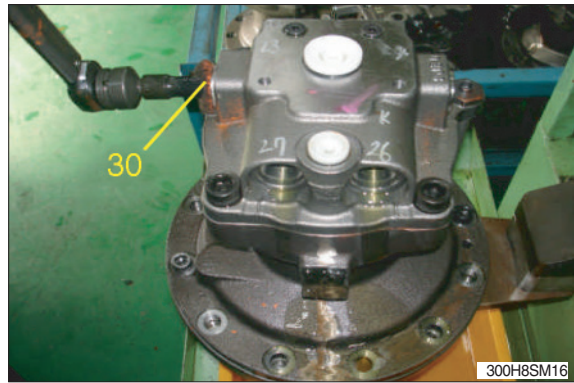

- (6) Disassemble plug (30), spring (33), check (32) from rear cover (25).

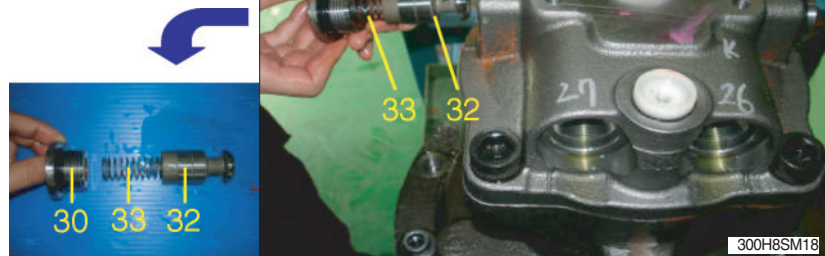

- (7) Disassemble reverse prevention valve assy from the rear cover (23).



- (8) Disassemble the four bolts (29).

Rear cover (23) is some disassembled from body (1) because of spring force

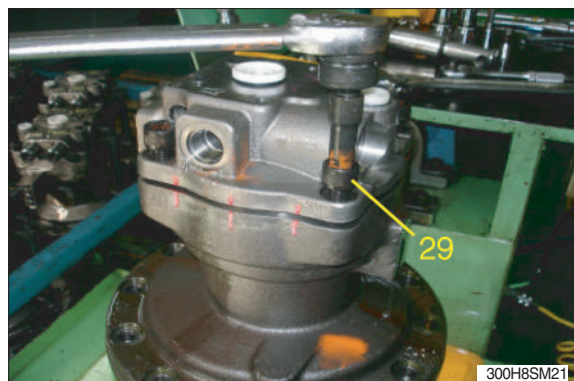

(9) Disassemble the rear cover (23) from the body (1).

※ Loosen the pipe screw before disassemble the rear cover (23).

The valve plate (28) may be disassembled with the rear cover (23).

Be careful lest the valve plate (28) remove from the rear cover (23).



(10) Disassemble all spring (22) from the brake piston (21).



(11) Use the brake piston removal tool to disassemble the brake piston (21).

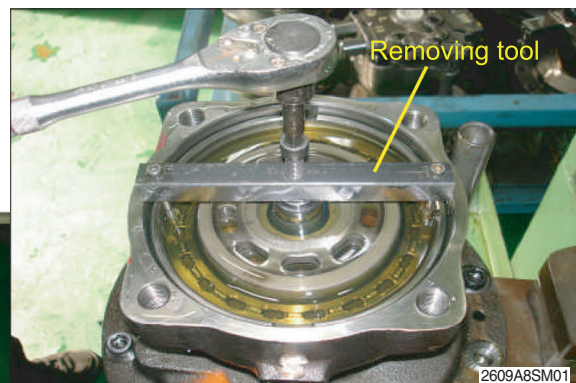
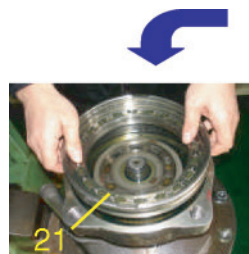

(12) The workbench horizontally, disassemble cylinder block assy (11) , friction plate (18) 2ea, plate (17) 3ea, from the shaft (5) safely.

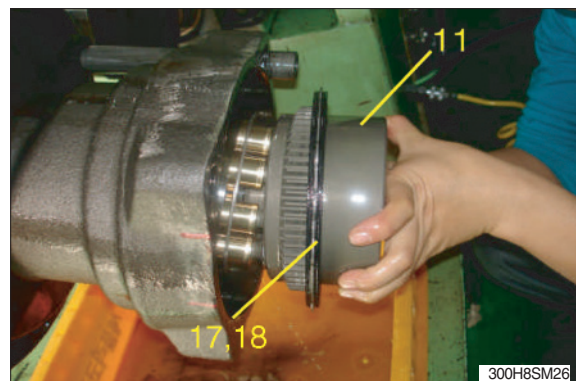

(13) Disassemble the shoe plate (8) from the body (1).

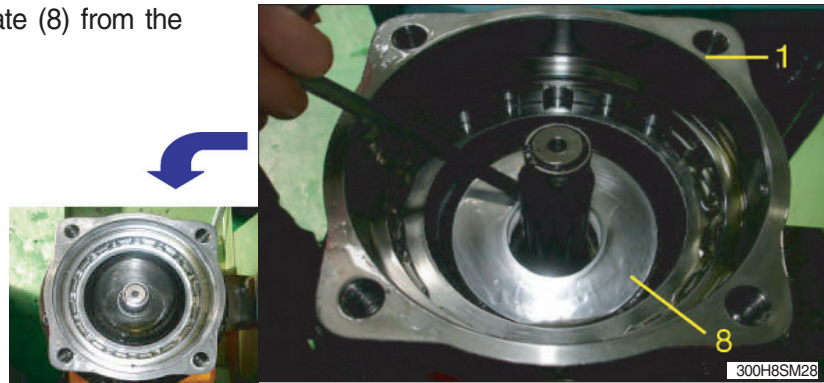

(14) Using a plier jig, dismantle snap ring (4) from shaft (5).

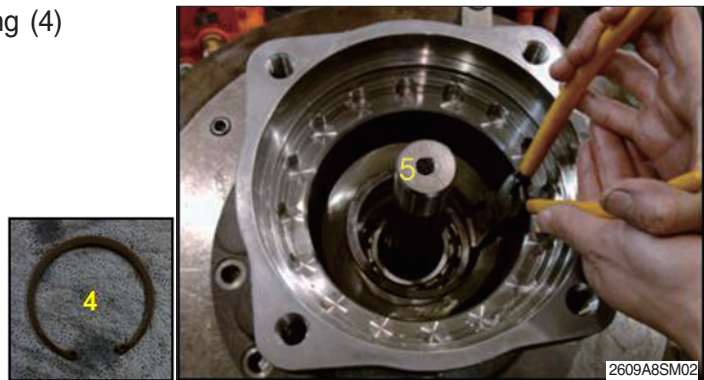

(15) Dismantle shaft assy from body (1).

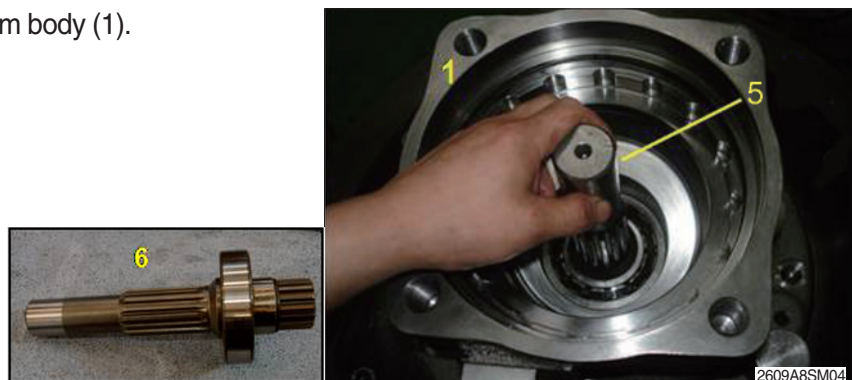

(16) Disassemble the oil seal (2) from the body (1).
(1).
Do not reuse the oil seal (2).

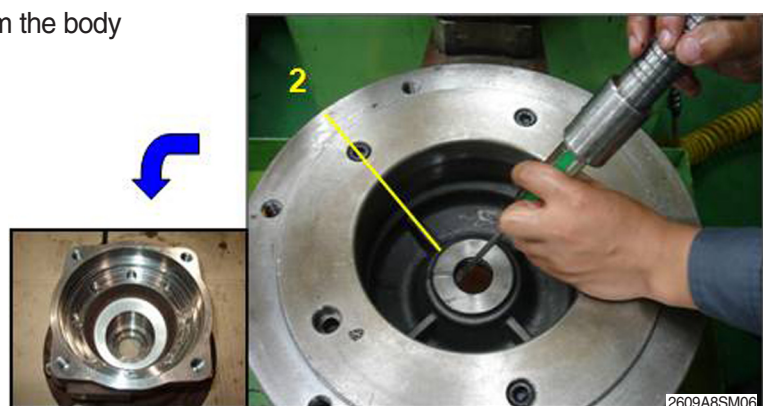

(17) After put on the shaft to jig, use the press to disassemble the bearing.
Do not reuse the bearing (3)

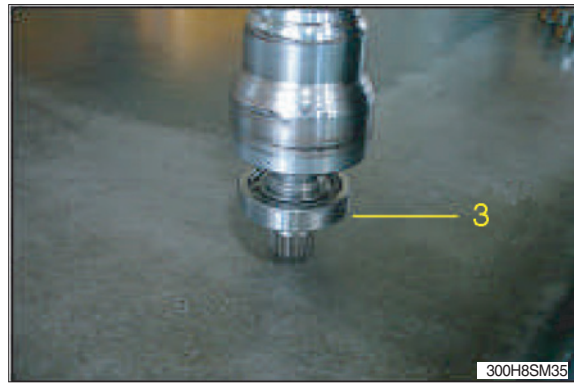

(18) Disassemble the valve plate (28) from the rear cover (23).

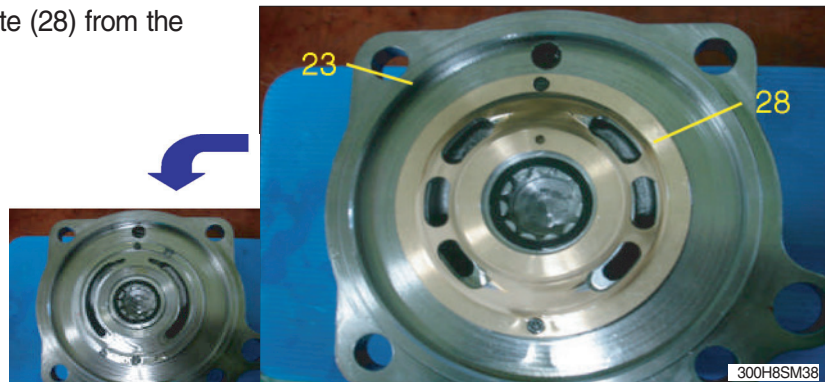

(19) Disassemble the O-ring (24) from rear cover (23) and body (1).

※ Damage of the O-ring and do not reuse if possible.

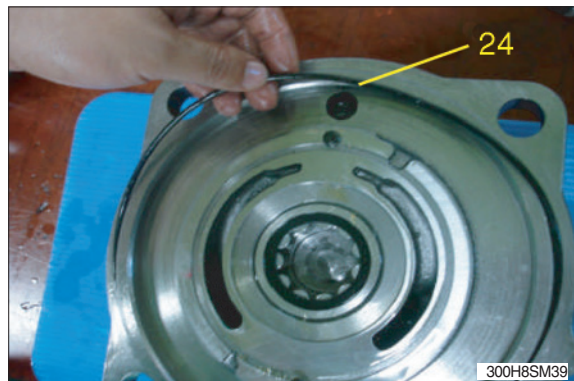

(20) Disassemble the roll bearing (25) from the rear cover (23) using the bearing puller.

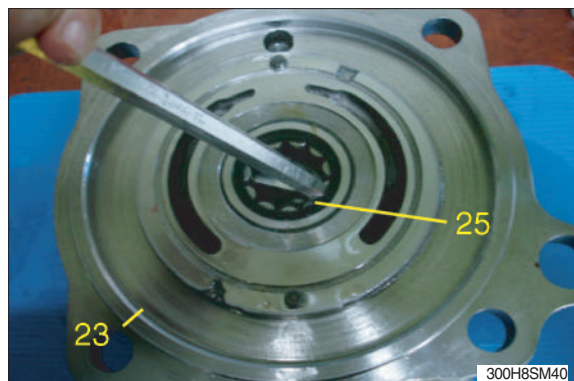

(21) Use the L-wrench to disassemble the plug (42) from the rear cover (23).

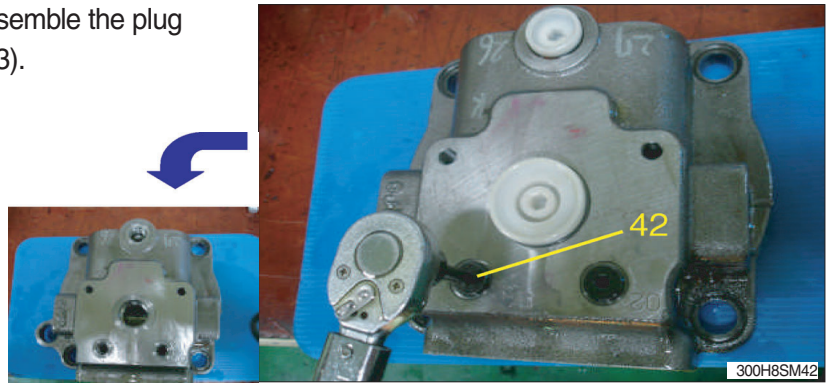

Disassembly has completed.

4) ASSEMBLY

(1) General precautions

- ① After washing each parts cleanly, dry it with compressed air.
- ② In bonding each part, fasten bond torque.
- ③ When using a hammer, do not forget to use a plastic hammer.

(2) Assembling swing motor

- ① Set up the body (1) on the workbench.

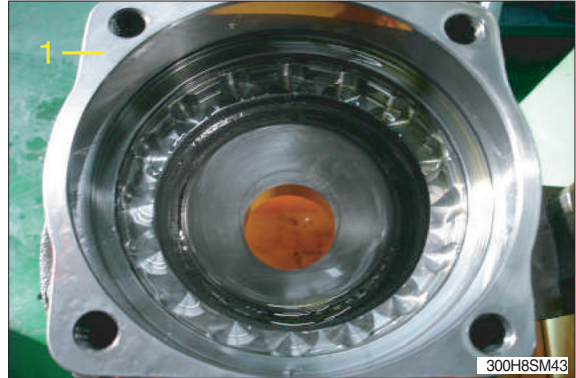

- ② Put roll bearing (3), bushing (6) on preheater and provide heat to inner wheel (Compressing temp : 290°C for 2 minutes).

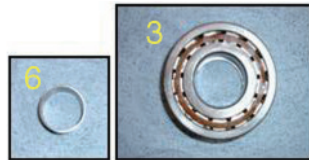

- ③ After assembling and compressing preheated roll bearing (3), bushing (6) into shaft (5).



- ④ Using a compressing tool and steel stick, assemble oil seal (2) into body (1).

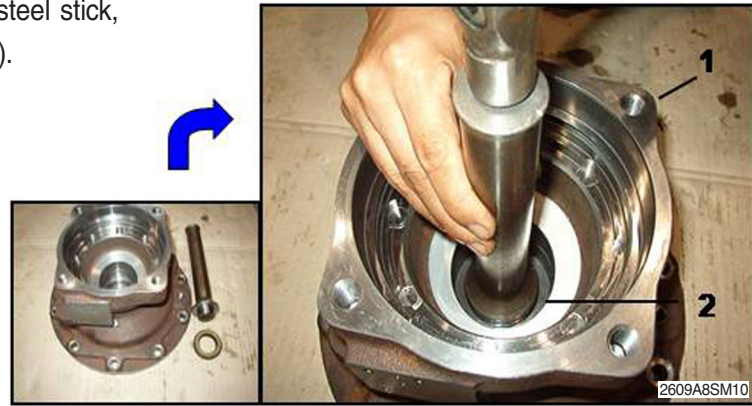

- ⑤ Fix snap ring (4) to shaft with a plier jig.

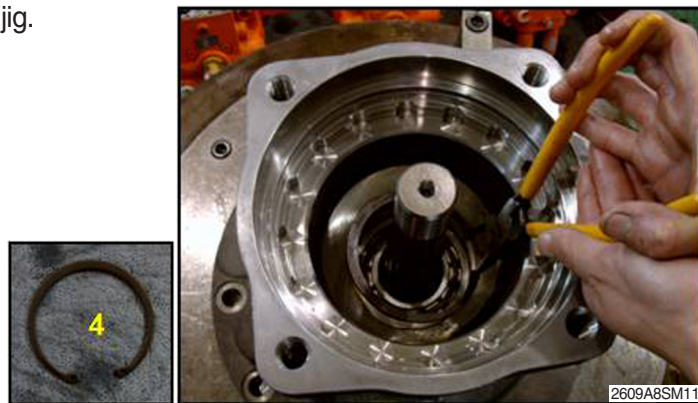

- ⑥ Assemble the shoe plate (8) in the body (1).

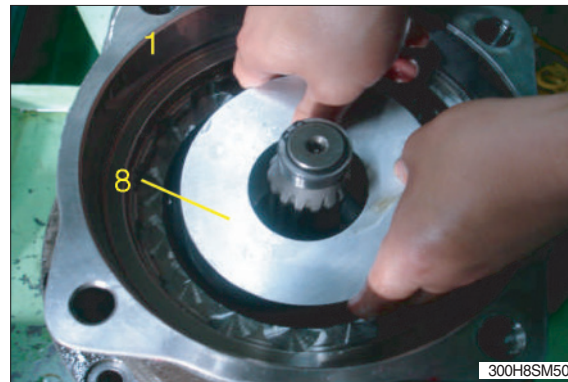

- ⑦ Like the figure, assemble the pin (13) and ball guide (14) in the cylinder block (10).



- ⑧ Assemble the piston assy (16) in the set plate (15).



- ⑨ Assemble the piston assy (16) in the cylinder block (9).
Apply the clean hydraulic oil in the piston assy and hole of cylinder block (9) before assemble the piston assy (16)

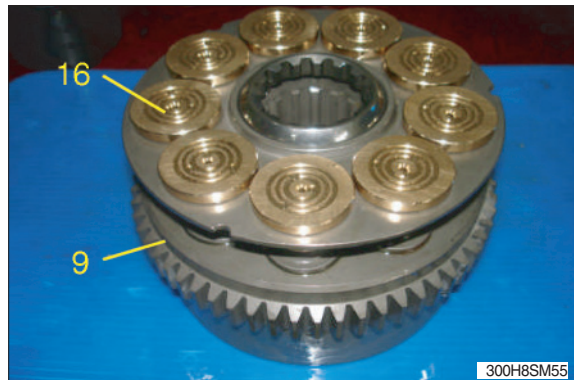

- ⑩ The workbench horizontally, assemble the cylinder block assy in the body (1) and insert the O-ring (19, 20).



- ⑪ Insert the O-ring (19, 20) in the body (1).

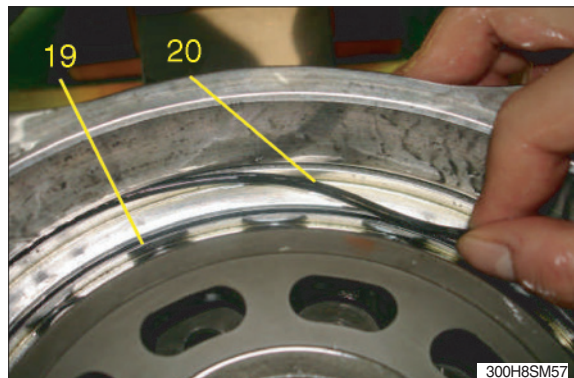

- ⑫ Like a figure, assemble two friction plate (18) and three plate (17) in the body (1).

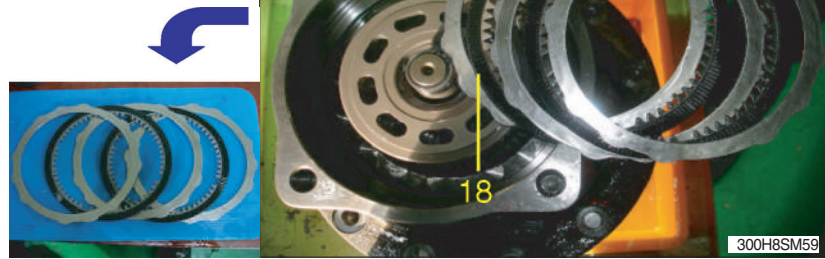

- ⑬ Assemble the brake piston (21) in the body (1).

- ※ The brake piston will not be assembled well.
In that case, after tighten M6 bolt in the hole of brake piston, hit them using the hammer.



- ⑭ Assemble twenty spring (22) in the brake piston (21).

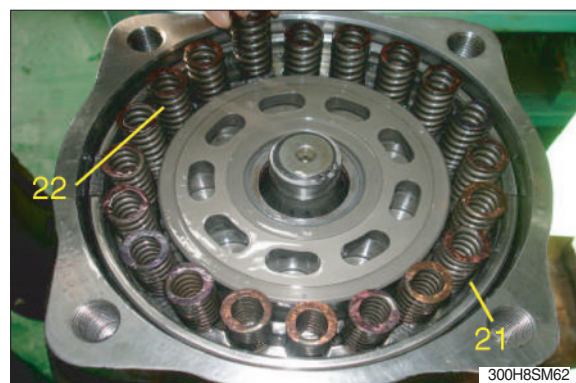

- ⑮ Use the jig to assemble the roller bearing (25) in the rear cover (23).



- ⑩ Use the jig to assemble the pin (27) in the rear cover (23).

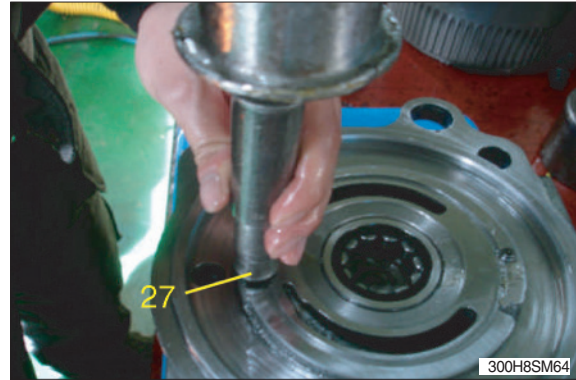

- ⑪ Insert the O-ring (24) in the rear cover (23).
Spread the lubricant in the O-ring.

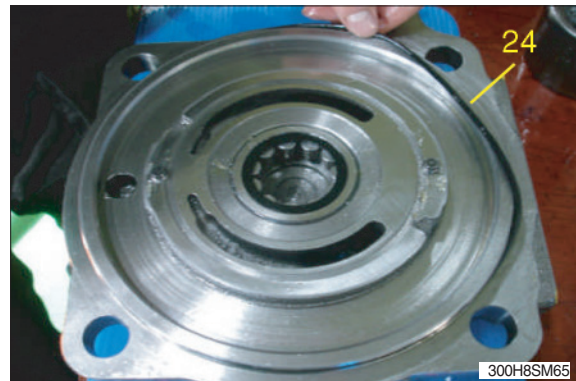

- ⑫ Assembles the valve plate (28) in the rear cover (23).

- ※ When assemble the valve plate in the rear cover, spread the lubricant a little in the fixed surface.
The notch which has orifice hole ($\varnothing 1.0$) of the valve plate is located in the other side of the flange face (A, B port)

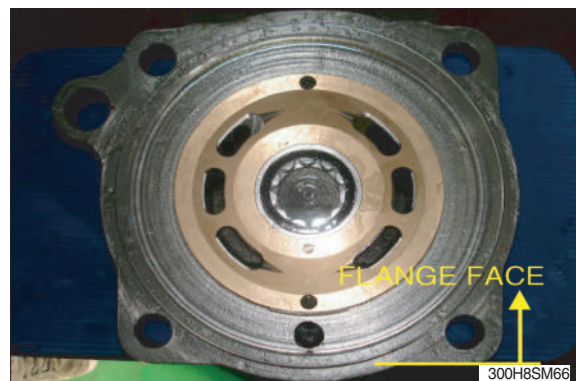

- ⑬ Assemble the rear cover (23) in the body (1).

- ※ Indicate the rear cover on fixed line.
Tight bolts with the specified torque.



- ⑳ Assemble the make up valve in the rear cover check that the check (32) should have been operated softly

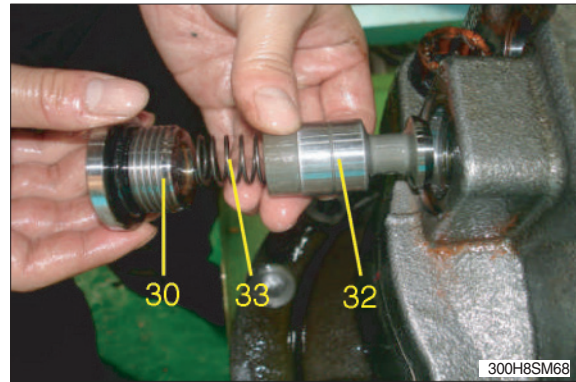

- ㉑ After assembling the reverse prevention valve assy in the rear cover (23), assembles the plug (35) which the O-ring inserted.

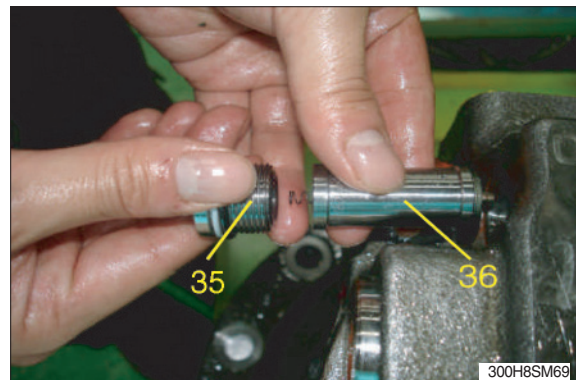

- ㉒ Use the wrench to assemble the relief valve assy (39) in the rear cover (23). Spread some lubricant in the O-ring of the relief valve assy.



- ㉓ Assemble the plug (42) in the cover (23) using the L-wrench.

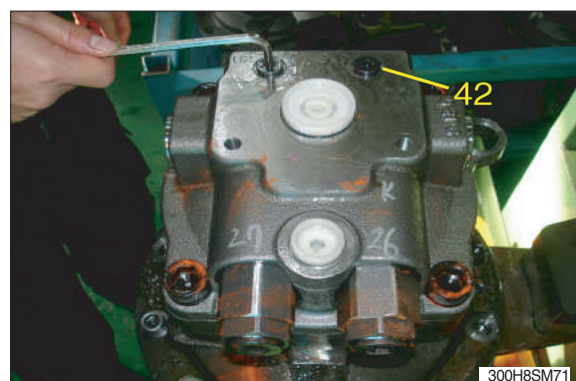

- ②④ Assemble the time delay valve assy (40) in the body (1) using the wrench bolt (41 3ea).

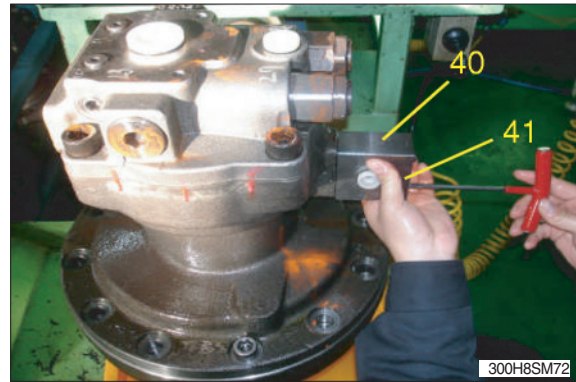

- ②⑤ After assemble the level gauge pipe (49) in the body (1) and rear cover (23), use the bolt to fix them.



Assembly has completed.

3. REMOVAL AND INSTALL OF REDUCTION GEAR

1) REMOVAL

- (1) Remove the swing motor assembly.
For details, see removal of swing motor assembly.
- (2) Sling reduction gear assembly (1) and remove mounting bolts (2).
- (3) Remove the reduction gear assembly.
 - Reduction gear device weight :
279 kg(615 lb)



2) INSTALL

- (1) Carry out installation in the reverse order to removal.
 - Tightening torque : $97.8 \pm 10 \text{ kgf} \cdot \text{m}$
($707 \pm 72.3 \text{ lbf} \cdot \text{ft}$)

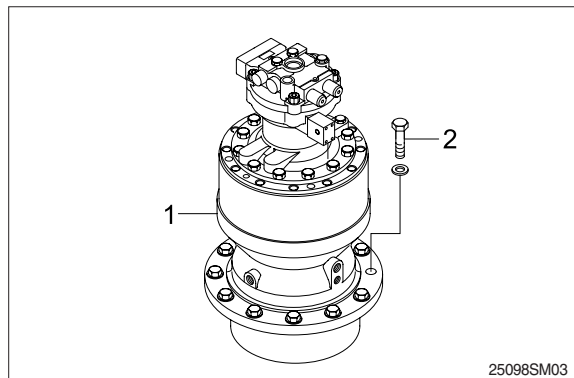

4. DISASSEMBLY AND ASSEMBLY OF REDUCTION GEAR

1) REDUCTION GEAR

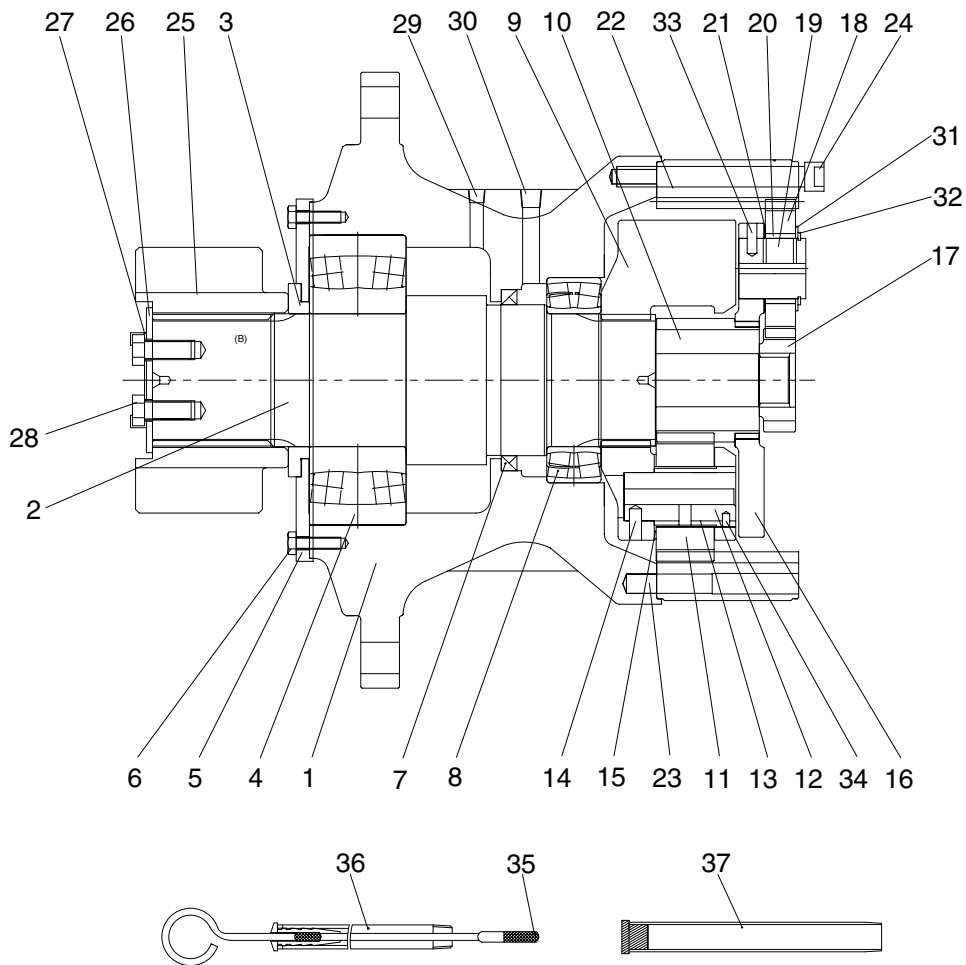

1	Casing	14	Spring pin	27	Lock washer
2	Drive shaft	15	Thrust washer	28	Hexagon bolt
3	Spacer	16	Carrier 1	29	Plug
4	Roller bearing	17	Sun gear 1	30	Plug
5	Cover plate	18	Planet gear 1	31	Side plate 2
6	Hexagon bolt	19	Pin 1	32	Stop ring
7	Oil seal	20	Needle cage	33	Spring pin
8	Roller bearing	21	Side plate 1	34	Spring pin
9	Carrier 2	22	Ring gear	35	Gage bar
10	Sun gear 2	23	Knock pin	36	Gage pipe
11	Planet gear 2	24	Socket bolt	37	Air breather assy
12	Pin 2	25	Pinion gear		
13	Bushing 2	26	Lock plate		

2507A2SM03

2) DISASSEMBLY

(1) SWING REDUCTION GEAR

- ① Remove plug (29, 30) and drain out gear oil.



- ② Loosen the socket bolts (24) to separate swing motor from reduction gear.



- ③ Move out No.1 sun gear (17) and No.1 carrier sub assy by using jig.



- ④ Full out No.2 sun gear (10).



- ⑤ Full out No.2 carrier sub assy by using jig and crane.
- ※ Pay attention to ensure gear is not damaged during disassembling.



- ⑥ Move out ring gear by the removal groove between ring gear (22) and casing (1) by using removal jig.



- ⑦ Full out knock pin (23).
- ※ Do not need to remove the knock pin if it is not worn or damaged.



- ⑧ Put it on the working table with drive shaft up.

- ⑨ Remove lock washer (27) by removal jig and loosen hex bolt (28) with fixing pinion gear (25) and thereafter plate lock (26) & pinion gear (25).



- ⑩ Loosen hex bolt (6) and remove spacer (3) and cover plate by screwing a removal bolt into tap hole on the cover plate (5).



- ⑪ Dismantle drive shaft by using jig
- ※ Removed oil seal should not be reused. Replace new oil seal when assembling.



(2) NO.1 CARRIER SUB ASSY

- ① Remove stop ring (32) and dismantle No.2 side plate (31) and No.1 planet gear (18).



- ② Dismantle needle cage (20) and No.1 side plate (21).

- ※ Do not need to dismantle No.1 pin, No.1 carrier and spring pin, when they have no problems.
- ※ Be sure to make a marking on the pin of each planet gear to ensure them to be placed in the same locations when assembling.

When need to dismantle pin. Hammer the section end of pin to pull out.



(3) NO.2 CARRIER SUB ASSY

- ① Remove spring pin (14) by hammering in a key to the opposite side of the No.2 pin.



② Full out No.2 pin assy

- ※ Do not reuse both the No.2 pin assy and spring pin.



(4) SHAFT ASSY

① Press drive shaft (2) by using jig to remove roller bearing.

- ※ Do not need to disassemble if it has no special problems.



3) ASSEMBLY

(1) NO.1 CARRIER SUB ASSY

① Place the No.1 carrier (16) horizontally on the work table. Fit the No.1 pin (19) into the hole of No.1 carrier (16) by hydraulic pressing machine.

- ※ Be careful to direct the pin (19) perpendicularly to the carrier (16) when pressing.



② Install the No.1 side plate (21) and needle cage (20) thereafter.



- ③ Put No.1 planet gear (18) and No.2 side plate (31) together and install a stop ring (32) by using assembling.



- ④ Insert spring pin (33) into the carrier sub-assembly by using jig and hammer.
- ※ Take care of planet gear1 (18) when assembling spring pin (33).

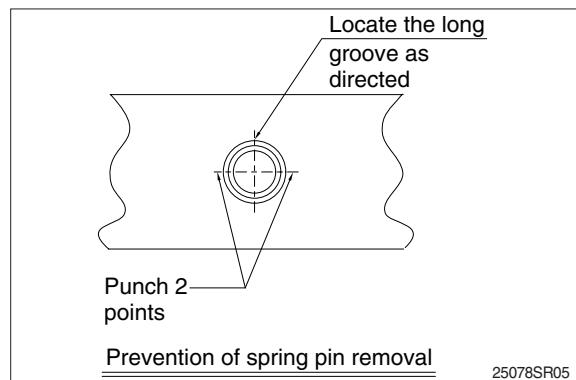

(2) ASSEMBLY-NO.2 CARRIER

- ① Place the thrust washer (15) on the No.2 carrier (9), meeting it with pin hole location. Be sure to check that the carrier (9) is not turned up side down when putting the washer (15).



- ② Place No.2 planet gear (11) onto the right location of the carrier (9).



- ③ Assemble the planet gears (11) and carrier (9) by inserting the pin assembly (12) using rubber hammer. Pay special attention to locate the spring pin hole to meet with the hole of the carrier (9).

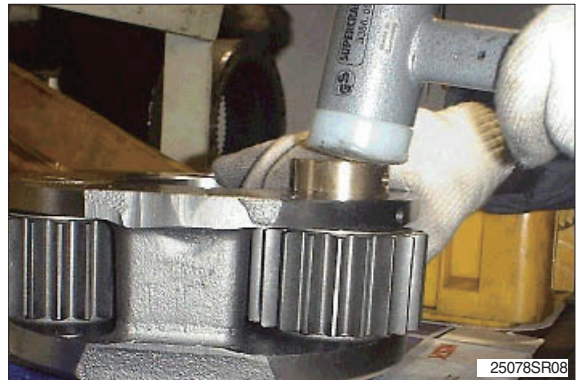

- ④ Insert spring pin (14) by using fixture and hammer.
- ※ Take care of planet gears (11) when hammering the pin (12).



- ⑤ After complete assembly, check if it revolves without problem when rotate the planet gears (11) by hand.
- ※ When problems found in revolution, disassemble it in reverse course and assemble again. Be sure to use new spring pin (14) when re-assembling.

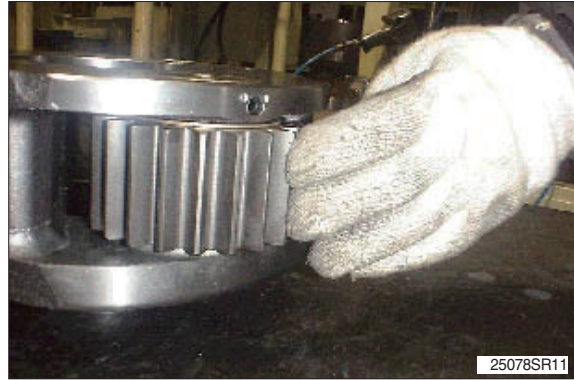

(3) SHAFT ASSY

- ① Heat roller bearing (4) with bearing heater up to about 80~100°C.
- ※ Be sure to keep the suggested heating temperature. Over heating may cause deformation.



- ② Demagnetize roller bearing (4) using demagnetizing machine.
- ※ Use special care to handle the bearing as it is very hot.



- ③ Place drive shaft (2) with positioning 2 tap holes upside.
- ④ Put bearing into drive shaft (2).
- ※ Be sure to prevent any contamination on the assembling surface during the install. Be sure to check by eye the surface of roller bearing (4) is completely contacting to the mating surface of the drive shaft (2).



- ⑤ Turn the drive shaft (2) to have the 2 tap hole side down and inject grease oil into roller bearing (4).
Recommended amount of grease is 1.4 kg (3.1pound).

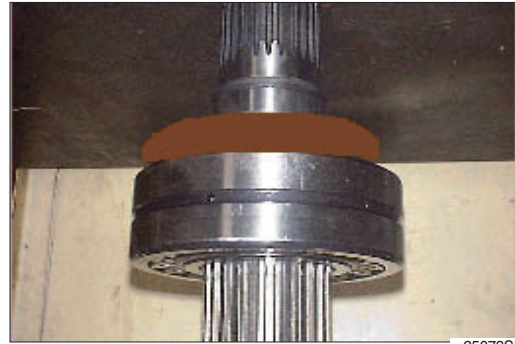

25078SR15

(4) CASE SUB ASSY

- ① Place the case (1) on the reversing machine, having the flange side of the case up.
- ② Tighten lifting bolts into the 2 Tap holes (M16) of shaft (2) and install shaft assembly (2) into case using crane.
- ※ Be sure to clean the case before install, using washing machine with the temperature of 80 °C (176 °F).
Do not install shaft assembly by force.



25078SR16

- ③ Assemble cover plate (5) and thereafter spacer (3).
- ※ Use jig when assembling spacer to be seated completely on surface.
Spread grease on the inner part of spacer.



25078SR17

- ④ Assemble cover plate (5) with case (1) after spreading loctite 262 and tighten hex bolt(M10) (6).



25078SR18

- ⑤ Install pinion gear (25).
Be careful to check right direction of pinion gear when installing.



- ⑥ Put lock plate (26) and lock washer (27), matching tap holes and tighten hex bolt (28).
· Tightening torque : 24 kgf · m
(173 lbf · ft)



- ※ When installing hex bolt (28), be sure to spread loctite 262.

- ⑦ To lock the bolts (28), bend the lock washer (27) to cover over the bolt head using jig.



- ⑧ Reverse case (1) and press to insert oil seal (7) by using jig after spreading grease oil on the outside ring of the seal. Coat grease oil slightly on the lip surface of the oil seal to prevent any scratch when installing.



- ※ Be sure to check by eye the oil seal (7) is seated completely after being installed.

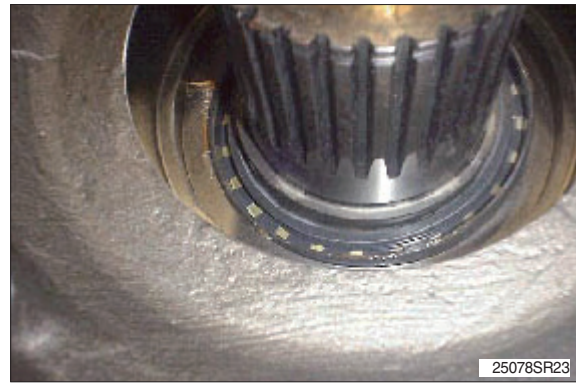

- ⑨ Spread loctite 609 on the outside ring of roller bearing (8) and insert the bearing (8) by using a pressing jig.



- ⑩ Clean the assembling surface of case and spread packing liquid (TH1105).



- ⑪ Place ring gear (22) on the case by matching knock pin hole.
 - ⑫ Insert 4 knock pins (23) by using jig.
- ※ Be sure to check the hole location of oil gage before inserting.



- ⑬ Assemble ring gear with case by screwing socket bolt (M16) (24). Spread loctite 262 on socket bolt (24) when installing.



- ⑭ Install drain plug (29,30) after winding sealing tape.



- ※ Leak test
- The successful assembly should have no air leakage when applied by 2 kgf/cm² of compressed air for about 3 minutes after being air sealed.

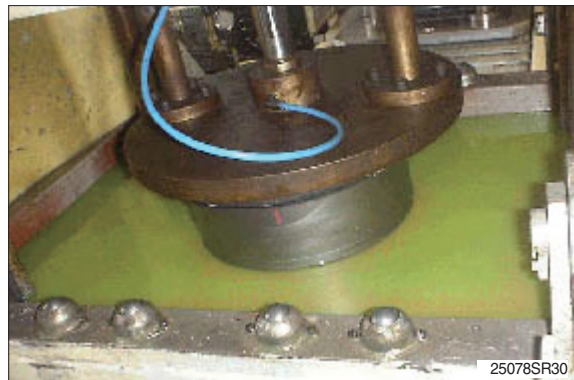

(5) SWING REDUCTION GEAR

- ① Mount No.2 carrier assembly in the case sub assembly and install bolts into 2 tap holes (M8).
 - ※ Turn the carrier slowly by hand to adjust the matching holes when assembling.

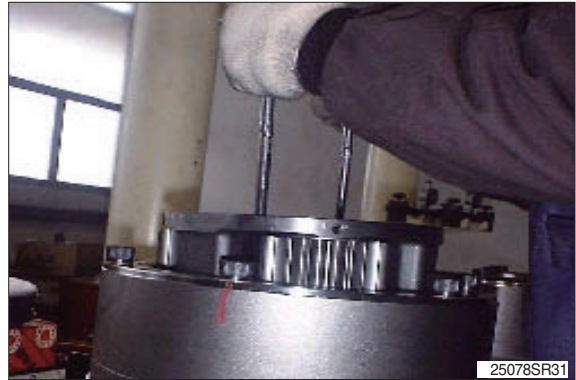

- ② Install No.2 sun gear (10).
 - ※ Be sure to check the direction of sun gear (10) when assembling.



- ③ Mount No.1 carrier assembly in the case sub assembly and install bolts into 2 tap holes (M8).
 - ※ Turn the carrier slowly by hand to adjust the catching holes when assembling.



- ④ Assemble No.1 sun gear (17).

