

GROUP 2 SPECIFICATIONS

1. MAJOR COMPONENT

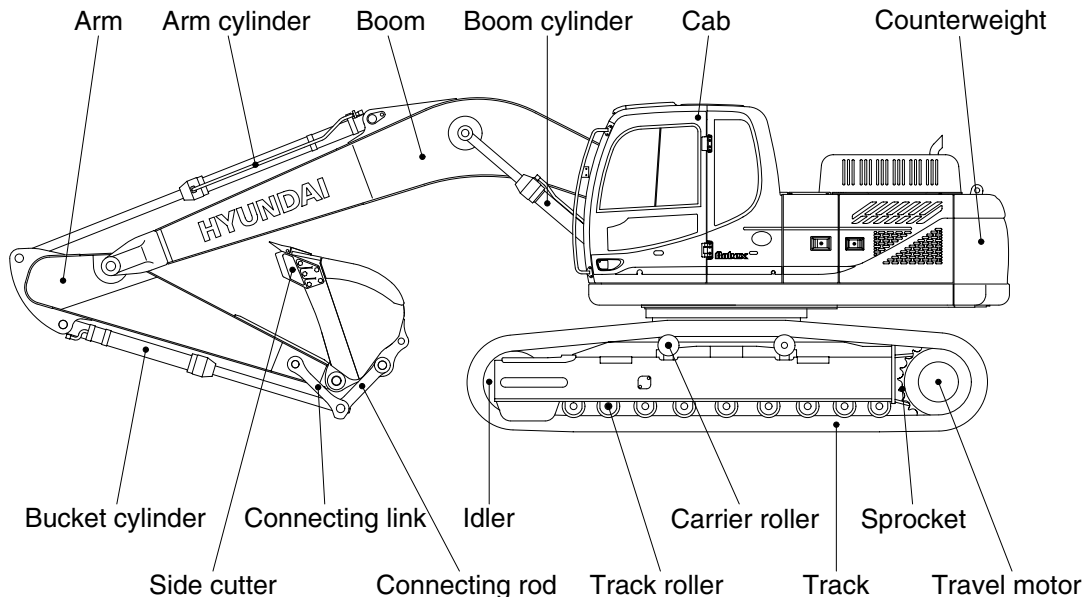
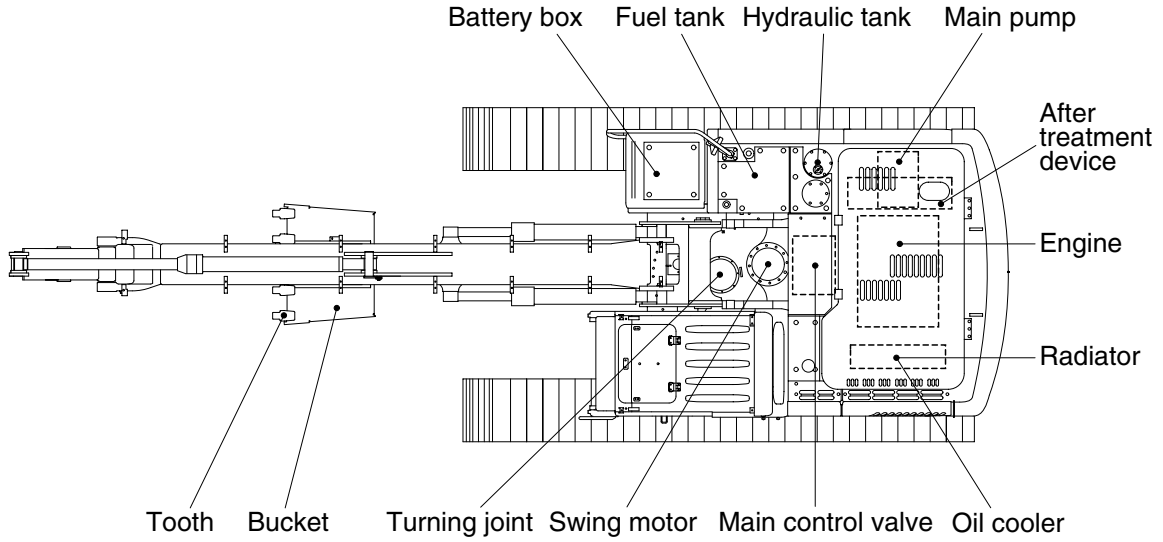

2609A2SP01

2. SPECIFICATIONS

1) R260LC-9A

· 5.85 m (19' 2") BOOM and 3.05 m (10' 0") ARM

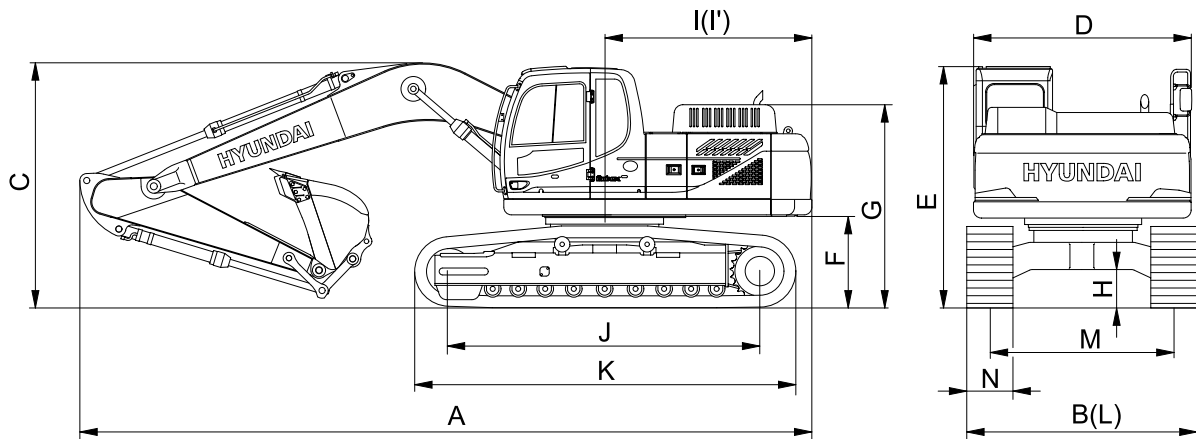

2609A2SP02

Description		Unit	Specification	
Operating weight		kg (lb)	25200 (55600)	
Bucket capacity (SAE heaped), standard		m ³ (yd ³)	1.08 (1.41)	
Overall length	A	mm (ft-in)	9920 (32' 7")	
Overall width, with 600mm shoe	B		3180 (10' 5")	
Overall height	C		3220 (10' 7")	
Superstructure width	D		2840 (9' 4")	
Overall height of cab	E		2990 (9' 10")	
Ground clearance of counterweight	F		1115 (3' 8")	
Engine cover height	G		2541 (8' 4")	
Minimum ground clearance	H		480 (1' 7")	
Rear-end distance	I		2870 (9' 5")	
Rear-end swing radius	I'		2975 (9' 9")	
Distance between tumbler	J		3830 (12' 7")	
Undercarriage length	K		4640 (15' 3")	
Undercarriage width	L		3180 (10' 5")	
Track gauge	M		2580 (8' 6")	
Track shoe width, standard	N		600 (24")	
Travel speed (low/high)			km/hr (mph)	3.3/5.6 (2.1/3.5)
Swing speed			rpm	11.6
Gradeability		Degree (%)	35 (70)	
Ground pressure (600 mm shoe)		kgf/cm ² (psi)	0.51 (7.25)	
Max traction force		kg (lb)	21600 (47600)	

2) R260NLC-9A

· 5.85 m (19' 2") BOOM and 3.05 m (10' 0") ARM

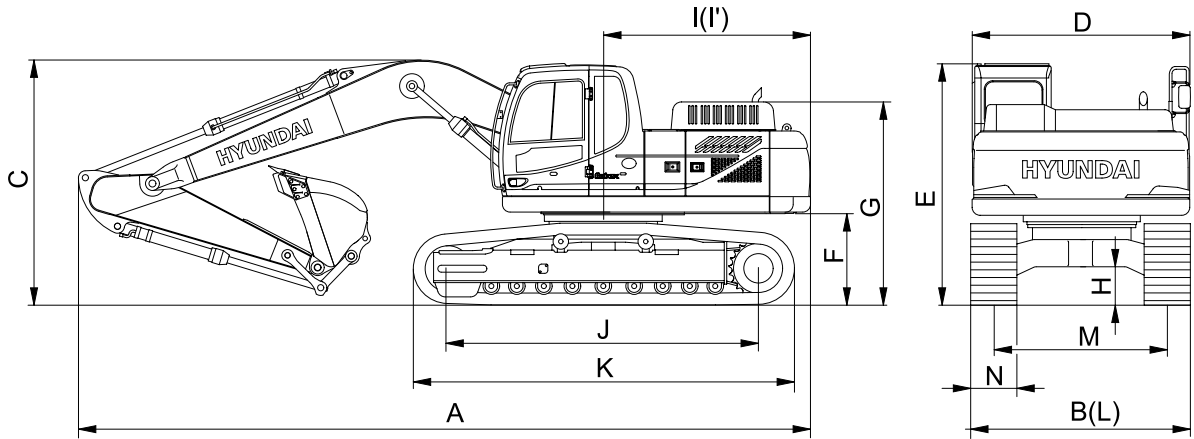

2609A2SP03

Description		Unit	Specification
Operating weight		kg (lb)	25100 (55300)
Bucket capacity (SAE heaped), standard		m ³ (yd ³)	1.08 (1.41)
Overall length	A	mm (ft-in)	9920 (32' 7")
Overall width, with 600 mm shoe	B		2980 (9' 9")
Overall height	C		3220 (10' 7")
Superstructure width	D		2840 (9' 4")
Overall height of cab	E		2990 (9' 10")
Ground clearance of counterweight	F		1115 (3' 8")
Engine cover height	G		2541 (8' 4")
Minimum ground clearance	H		480 (1' 7")
Rear-end distance	I		2870 (9' 5")
Rear-end swing radius	I'		2975 (9' 9")
Distance between tumbler	J		3830 (12' 7")
Undercarriage length	K		4640 (15' 3")
Undercarriage width	L		2980 (9' 9")
Track gauge	M		2380 (7' 10")
Track shoe width, standard	N		600 (24")
Travel speed (low/high)			km/hr (mph)
Swing speed		rpm	11.6
Gradeability		Degree (%)	35 (70)
Ground pressure (600 mm shoe)		kgf/cm ² (psi)	0.51 (7.25)
Max traction force		kg (lb)	21600 (47600)

3) R260LC-9A HIGH WALKER

· 5.85 m (19' 2") BOOM and 3.05 m (10' 0") ARM

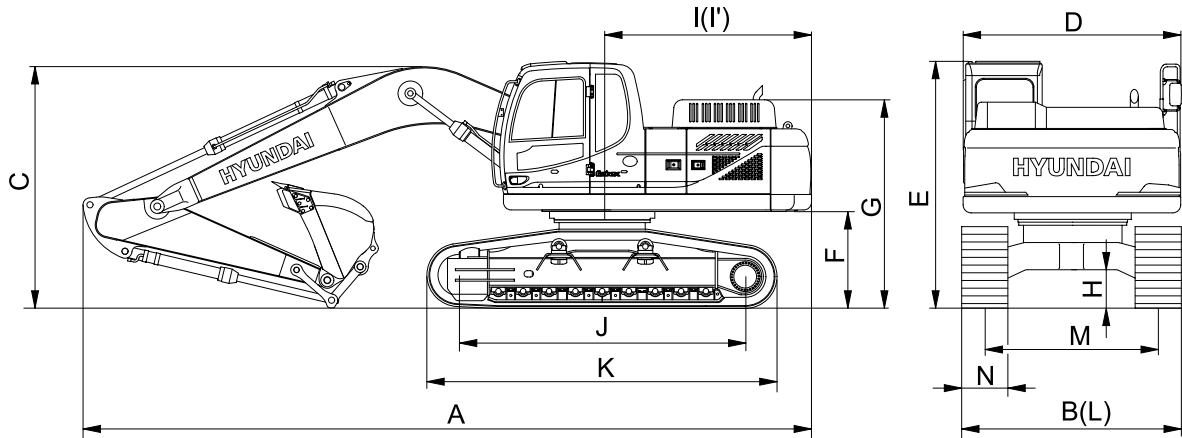

2609A2SP04

Description		Unit	Specification
Operating weight		kg (lb)	27450 (60520)
Bucket capacity (SAE heaped), standard		m ³ (yd ³)	1.08 (1.41)
Overall length	A	mm (ft-in)	9760 (32' 0")
Overall width, with 600 mm shoe	B		3390 (11' 1")
Overall height	C		3240 (10' 8")
Superstructure width	D		2840 (9' 4")
Overall height of cab	E		3345 (11' 0")
Ground clearance of counterweight	F		1470 (4' 10")
Engine cover height	G		2896 (9' 6")
Minimum ground clearance	H		765 (2' 6")
Rear-end distance	I		2870 (9' 5")
Rear-end swing radius	I'		2975 (9' 9")
Distance between tumbler	J		4030 (13' 3")
Undercarriage length	K		4940 (16' 2")
Undercarriage width	L		3390 (11' 1")
Track gauge	M		2790 (9' 2")
Track shoe width, standard	N		600 (24")
Travel speed (low/high)		km/hr (mph)	2.7/4.8 (1.7/3.0)
Swing speed		rpm	11.6
Gradeability		Degree (%)	35 (70)
Ground pressure (600 mm shoe)		kgf/cm ² (psi)	0.53 (7.54)
Max traction force		kg (lb)	21600 (47600)

3. WORKING RANGE

1) R260LC-9A, R260NLC-9A [5.85 m (19' 2") BOOM]

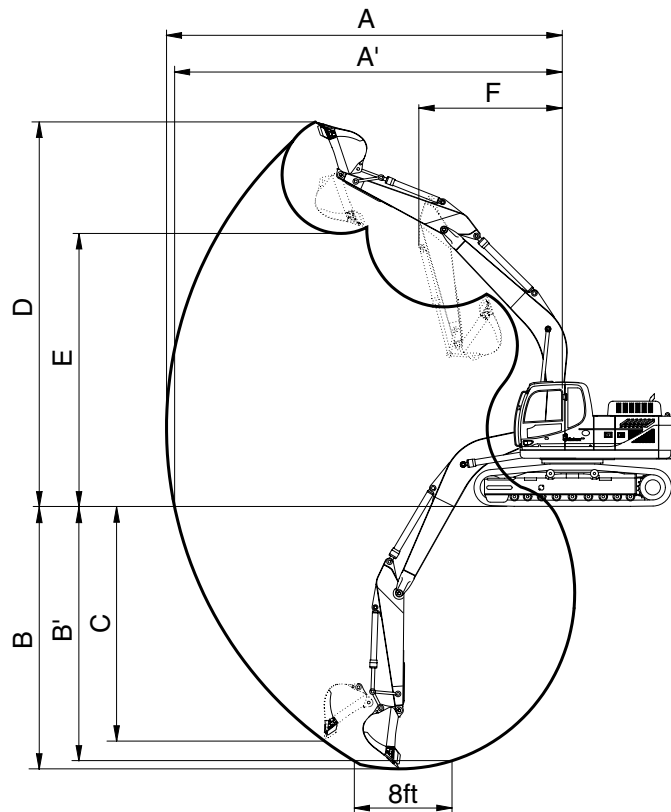

2609A2SP05

Description		2.10m (6' 11") Arm	2.50m (8' 2") Arm	※3.05m (10' 0") Arm	3.60m (11' 10") Arm
Max digging reach	A	9550 mm (31' 4")	9870 mm (32' 5")	10360 mm (34' 0")	10870 mm (35' 8")
Max digging reach on ground	A'	9360 mm (30' 9")	9680 mm (31' 9")	10190 mm (33' 5")	10700 mm (35' 1")
Max digging depth	B	6050 mm (19'10")	6450 mm (21' 2")	7000 mm (23' 0")	7550 mm (24' 9")
Max digging depth (8 ft level)	B'	5840 mm (19' 2")	6260 mm (20' 6")	6830 mm (22' 5")	7400 mm (24' 3")
Max vertical wall digging depth	C	5480 mm (18' 0")	5640 mm (18' 6")	6150 mm (20' 2")	6830 mm (22' 5")
Max digging height	D	9450 mm (31' 0")	9460 mm (31' 0")	9670 mm (31' 9")	9920 mm (32' 7")
Max dumping height	E	6360 mm (20'10")	6420 mm (21' 1")	6630 mm (21' 9")	6860 mm (22' 6")
Min swing radius	F	4420 mm (14' 6")	4200 mm (13' 9")	3980 mm (13' 1")	3900 mm (12'10")
Bucket digging force	SAE	156.9 [170.4] kN	156.9 [170.4] kN	156.9 [170.4] kN	156.9 [170.4] kN
		16000 [17370] kgf	16000 [17370] kgf	16000 [17370] kgf	16000 [17370] kgf
		35270 [38290] lbf	35270 [38290] lbf	35270 [38290] lbf	35270 [38290] lbf
	ISO	178.5 [193.8] kN	178.5 [193.8] kN	178.5 [193.8] kN	178.5 [193.8] kN
		18200 [19760] kgf	18200 [19760] kgf	18200 [19760] kgf	18200 [19760] kgf
		40120 [43560] lbf	40120 [43560] lbf	40120 [43560] lbf	40120 [43560] lbf
Arm digging force	SAE	134.4 [145.9] kN	130.4 [141.6] kN	114.7 [124.6] kN	104.0 [112.9] kN
		13700 [14870] kgf	13300 [14440] kgf	11700 [12700] kgf	10600 [11510] kgf
		30200 [32790] lbf	29320 [31830] lbf	25790 [28000] lbf	23370 [25370] lbf
	ISO	139.3 [151.2] kN	134.4 [145.9] kN	118.7 [128.8] kN	107.9 [117.1] kN
		14200 [15420] kgf	13700 [14870] kgf	12100 [13140] kgf	11000 [11940] kgf
		31310 [33990] lbf	30200 [32790] lbf	26680 [28970] lbf	24250 [26330] lbf

[] : Power boost ※ : STD

2) R260LC-9A HIGH WALKER [5.85 m (19' 2") BOOM]

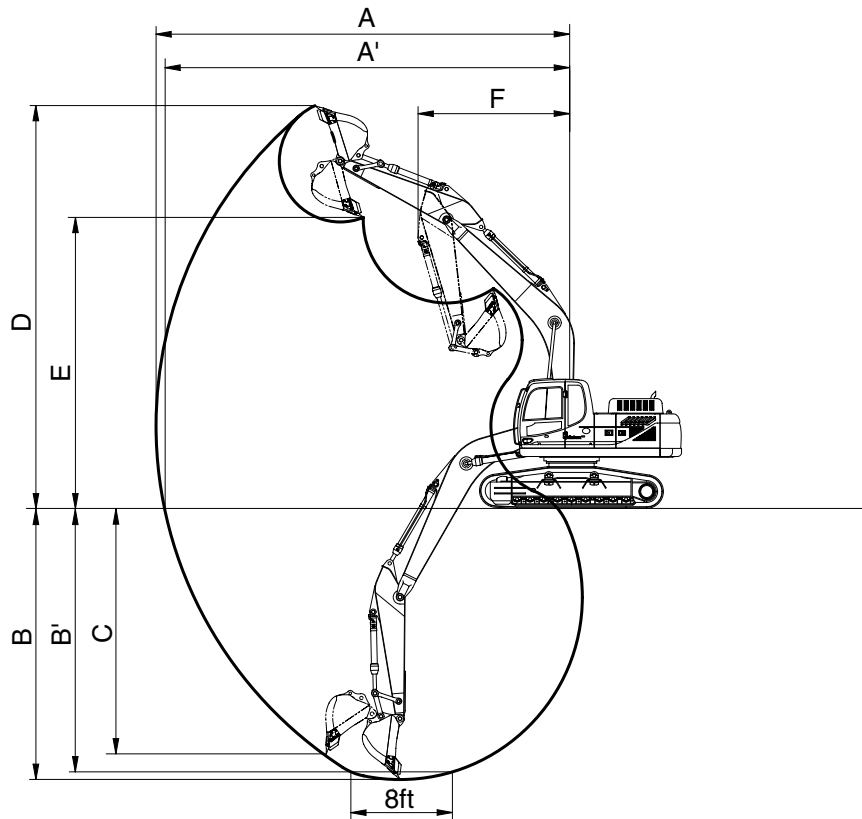

2609A2SP06

Description		2.10m (6' 11") Arm	2.50m (8' 2") Arm	※3.05m (10' 0") Arm	3.60m (11' 10") Arm
Max digging reach	A	9550 mm (31' 4")	9870 mm (32' 5")	10360 mm (34' 0")	10870 mm (35' 8")
Max digging reach on ground	A'	9280 mm (30' 5")	9160 mm (30' 1")	10110 mm (33' 2")	10360 mm (34' 0")
Max digging depth	B	5680 mm (18' 8")	6080 mm (19' 11")	6630 mm (21' 9")	7180 mm (23' 7")
Max digging depth (8 ft level)	B'	5470 mm (17' 11")	5890 mm (19' 4")	6460 mm (21' 2")	7030 mm (23' 1")
Max vertical wall digging depth	C	5120 mm (16' 10")	5300 mm (17' 5")	5790 mm (19' 0")	6470 mm (21' 3")
Max digging height	D	9820 mm (32' 3")	9840 mm (32' 3")	10040 mm (32' 11")	10280 mm (33' 9")
Max dumping height	E	6730 mm (22' 1")	6790 mm (22' 3")	7000 mm (23' 0")	7220 mm (23' 8")
Min swing radius	F	4140 mm (13' 7")	4030 mm (13' 3")	3940 mm (12' 11")	3900 mm (12' 10")
Bucket digging force	SAE	156.9 [170.4] kN	156.9 [170.4] kN	156.9 [170.4] kN	156.9 [170.4] kN
		16000 [17370] kgf	16000 [17370] kgf	16000 [17370] kgf	16000 [17370] kgf
		35270 [38290] lbf	35270 [38290] lbf	35270 [38290] lbf	35270 [38290] lbf
	ISO	178.5 [193.8] kN	178.5 [193.8] kN	178.5 [193.8] kN	178.5 [193.8] kN
		18200 [19760] kgf	18200 [19760] kgf	18200 [19760] kgf	18200 [19760] kgf
		40120 [43560] lbf	40120 [43560] lbf	40120 [43560] lbf	40120 [43560] lbf
Arm crowd force	SAE	134.4 [145.9] kN	130.4 [141.6] kN	114.7 [124.6] kN	104.0 [112.9] kN
		13700 [14870] kgf	13300 [14440] kgf	11700 [12700] kgf	10600 [11510] kgf
		30200 [32790] lbf	29320 [31830] lbf	25790 [28000] lbf	23370 [25370] lbf
	ISO	139.3 [151.2] kN	134.4 [145.9] kN	118.7 [128.8] kN	107.9 [117.1] kN
		14200 [15420] kgf	13700 [14870] kgf	12100 [13140] kgf	11000 [11940] kgf
		31310 [33990] lbf	30200 [32790] lbf	26680 [28970] lbf	24250 [26330] lbf

[] : Power boost ※ : STD

4. WEIGHT

1) R260LC-9A, R260NLC-9A

Item	R260LC-9A		R260NLC-9A	
	kg	lb	kg	lb
Upperstructure assembly	10500	23150	←	←
Main frame weld assembly	2360	5200	←	←
Engine assembly	520	1150	←	←
Main pump assembly	136	300	←	←
Main control valve assembly	220	485	←	←
Swing motor assembly	345	760	←	←
Hydraulic oil tank assembly	220	485	←	←
Fuel tank assembly	200	440	←	←
Counterweight	4600	10140	←	←
Cab assembly	310	680	←	←
Lower chassis assembly	9750	21500	9650	21270
Track frame weld assembly	3070	6770	2980	6570
Swing bearing	280	800	←	←
Travel motor assembly	276	608	←	←
Turning joint	53	117	←	←
Track recoil spring	140	309	←	←
Idler	160	353	←	←
Carrier roller	20	45	←	←
Track roller	40	88	←	←
Track-chain assembly (600 mm standard triple grouser shoe)	1500	3310	←	←
Front attachment assembly (5.85 m boom, 3.05 m arm, 1.08 m ³ SAE heaped bucket)	4950	10910	←	←
5.85 m boom assembly	1940	4280	←	←
3.05 m arm assembly	1020	2250	←	←
1.08 m ³ SAE heaped bucket	910	2010	←	←
Boom cylinder assembly	240	530	←	←
Arm cylinder assembly	340	750	←	←
Bucket cylinder assembly	220	490	←	←
Bucket control rod assembly	110	240	←	←

2) R260LC-9A HIGH WALKER

Item	R260LC-9A HIGH WALKER	
	kg	lb
Upperstructure assembly	10500	23150
Main frame weld assembly	2360	5200
Engine assembly	520	1150
Main pump assembly	136	300
Main control valve assembly	220	485
Swing motor assembly	345	760
Hydraulic oil tank assembly	220	485
Fuel tank assembly	200	440
Counterweight	4600	10140
Cab assembly	310	680
Lower chassis assembly	12000	26460
Track frame weld assembly	5280	11640
Swing bearing	360	800
Travel motor assembly	360	800
Turning joint	53	117
Track recoil spring	200	440
Idler	250	550
Carrier roller	55	120
Track roller	55	120
Track-chain assembly (600 mm standard triple grouser shoe)	1860	4100
Front attachment assembly (5.85 m boom, 3.05 m arm, 1.08 m ³ SAE heaped bucket)	4950	10910
5.85 m boom assembly	1940	4280
3.05 m arm assembly	1020	2250
1.08 m ³ SAE heaped bucket	910	2010
Boom cylinder assembly	240	530
Arm cylinder assembly	340	750
Bucket cylinder assembly	220	490
Bucket control rod assembly	110	240











5. LIFTING CAPACITIES

1) R260LC-9A

(1) 5.85 m (19' 2") boom, 2.10 m (6' 11") arm equipped with 1.08 m³ (SAE heaped) bucket and 600 mm (24") triple grouser shoe.

·  : Rating over-front

·  : Rating over-side or 360 degree

Load point height		Load radius								At max. reach		
		3.0 m (10 ft)		4.5 m (15 ft)		6.0 m (20 ft)		7.5 m (25 ft)		Capacity		Reach
												m (ft)
6.0 m (20 ft)	kg lb					*5790 *12760	*5790 *12760			5220 11510	3200 7050	8.32 (27.3)
4.5 m (15 ft)	kg lb			*7810 *17220	*7810 *17220	*6510 *14350	5570 12280	*6000 *13230	3690 8140	4520 9960	2710 5970	8.91 (29.2)
3.0 m (10 ft)	kg lb			*10260 *22620	8200 18080	*7600 *16760	5190 11440	5900 13010	3550 7830	4210 9280	2480 5470	9.17 (30.1)
1.5 m (5 ft)	kg lb			*12300 *27120	7520 16580	8250 18190	4850 10690	5720 12610	3380 7450	4170 9190	2430 5360	9.14 (30.0)
Ground Line	kg lb			13110 28900	7250 15980	8010 17660	4640 10230	5600 12350	3270 7210	4410 9720	2580 5690	8.80 (28.9)
-1.5 m (-5 ft)	kg lb	*15460 *34080	15160 33420	13090 28860	7230 15940	7940 17500	4580 10100			5060 11160	2990 6590	8.13 (26.7)
-3.0 m (-10 ft)	kg lb	*17100 *37700	15470 34110	*12090 *26650	7390 16290	8050 17750	4680 10320			*6290 *13870	3980 8770	6.98 (22.9)
-4.5 m (-15 ft)	kg lb	*13360 *29450	*13360 *29450	*9460 *20860	7790 17170							











- Note
1. Lifting capacity are based on SAE J1097 and ISO 10567.
 2. Lifting capacity of the ROBEX series does not exceed 75% of tipping load with the machine on firm, level ground or 87% of full hydraulic capacity.
 3. The load point is a hook (standard equipment) located on the back of the bucket.
 4. *indicates load limited by hydraulic capacity.

2) R260NLC-9A

(1) 5.85 m (19' 2") boom, 2.10 m (6' 11") arm equipped with 1.08 m³ (SAE heaped) bucket and 600 mm (24") triple grouser shoe.

·  : Rating over-front

·  : Rating over-side or 360 degree

Load point height		Load radius								At max. reach		
		3.0 m (10 ft)		4.5 m (15 ft)		6.0 m (20 ft)		7.5 m (25 ft)		Capacity		Reach m (ft)
												
6.0 m (20 ft)	kg lb					*5790 *12760	5290 11660			5200 11460	2870 6330	8.32 (27.3)
4.5 m (15 ft)	kg lb			*7810 *17220	*7810 *17220	*6510 *14350	5030 11090	*6000 *13230	3310 7300	4500 9920	2410 5310	8.91 (29.2)
3.0 m (10 ft)	kg lb			*10260 *22620	7330 16160	*7600 *16760	4660 10270	5870 12940	3170 6990	4190 9240	2190 4830	9.17 (30.1)
1.5 m (5 ft)	kg lb			*12300 *27120	6670 14700	8210 18100	4330 9550	5690 12540	3010 6640	4150 9150	2150 4740	9.14 (30.0)
Ground Line	kg lb			13050 28770	6410 14130	7970 17570	4120 9080	5570 12280	2900 6390	4390 9680	2280 5030	8.80 (28.9)
-1.5 m (-5 ft)	kg lb	*15460 *34080	13120 28920	13030 28730	6390 14090	7900 17420	4060 8950			5040 11110	2660 5860	8.13 (26.7)
-3.0 m (-10 ft)	kg lb	*17100 *37700	13420 29590	*12090 *26650	6540 14420	8020 17680	4160 9170			*6290 *13870	3560 7850	6.98 (22.9)
-4.5 m (-15 ft)	kg lb	*13360 *29450	*13360 *29450	*9460 *20860	6930 15280							











- Note
1. Lifting capacity are based on SAE J1097 and ISO 10567.
 2. Lifting capacity of the ROBEX series does not exceed 75% of tipping load with the machine on firm, level ground or 87% of full hydraulic capacity.
 3. The load point is a hook located on the back of the bucket.
 4. *indicates load limited by hydraulic capacity.

3) R260LC-9A HIGH WALKER

(1) 5.85 m (19' 2") boom, 2.10 m (6' 11") arm equipped with 1.08 m³ (SAE heaped) bucket, 600 mm (24") triple grouser shoe.

·  : Rating over-front

·  : Rating over-side or 360 degree

Load point height		Load radius								At max. reach		
		3.0 m (10 ft)		4.5 m (15 ft)		6.0 m (20 ft)		7.5 m (25 ft)		Capacity		Reach m (ft)
												
6.0 m (20 ft)	kg lb					*5910 *13030	*5910 *13030			*5290 *11660	3780 8330	8.49 (27.9)
4.5 m (15 ft)	kg lb			*8350 *18410	*8350 *18410	*6750 *14880	6680 14730	*6080 *13400	4530 9990	5310 11710	3310 7300	9.00 (29.5)
-3.0 m (-10 ft)	kg lb			*10830 *23880	9880 21780	*7870 *17350	6290 13870	*6580 *14510	4370 9630	5040 11110	3110 6860	9.19 (30.2)
-1.5 m (-5 ft)	kg lb			*12610 *27800	9280 20460	*8890 *19600	5970 13160	6840 15080	4210 9280	5080 11200	3120 6860	9.09 (30.2)
Ground Line	kg lb			*13240 *29190	9080 20020	*9480 *20900	5790 12760	6740 14860	4120 9080	5450 12020	3360 7410	8.68 (28.5)
-1.5 m (-5 ft)	kg lb	*17510 *38600	*17510 *38600	*12940 *28530	9100 20060	*9460 *20860	5760 12700			*6350 *14000	3950 8710	7.91 (26.0)
-3.0 m (-10 ft)	kg lb	*16440 *36240	*16440 *36240	*11670 *25730	9310 20530	*8440 *18610	5920 13050			*6190 *13650	5420 11950	6.61 (21.7)

- Note
1. Lifting capacity are based on SAE J1097 and ISO 10567.
 2. Lifting capacity of the ROBEX series does not exceed 75% of tipping load with the machine on firm, level ground or 87% of full hydraulic capacity.
 3. The load point is a hook located on the back of the bucket.
 4. * indicates load limited by hydraulic capacity.

6. BUCKET SELECTION GUIDE

1) GENERAL BUCKET

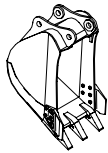
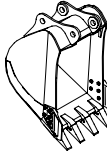
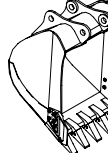
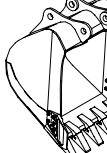
			
0.60 m ³ SAE 0.79 m ³ SAE heaped bucket	1.03 m ³ SAE heaped bucket	※ 1.08 m ³ SAE heaped bucket	1.27 m ³ SAE 1.50 m ³ SAE heaped bucket

Capacity		Width		Weight	Recommendation			
SAE heaped	CECE heaped	Without side cutter	With side cutter		5.85m (19' 2") boom			
					2.1m arm (6' 11")	2.5m arm (8' 2")	3.05m arm (10' 0")	3.6m arm (11' 10")
0.60 m ³ (0.78 yd ³)	0.55 m ³ (0.72 yd ³)	760 mm (29.9")	880 mm (34.6")	720 kg (1590 lb)				
0.79 m ³ (1.03 yd ³)	0.70 m ³ (0.92 yd ³)	890 mm (35.0")	1010 mm (39.8")	790 kg (1740 lb)				
1.03 m ³ (1.35 yd ³)	0.90 m ³ (1.18 yd ³)	1090 mm (42.9")	1210 mm (47.6")	890 kg (1960 lb)				
※ 1.08 m ³ (1.41 yd ³)	0.95 m ³ (1.24 yd ³)	1130 mm (44.5")	1250 mm (49.2")	910 kg (2010 lb)				
1.27 m ³ (1.66 yd ³)	1.10 m ³ (1.44 yd ³)	1290 mm (50.8")	1410 mm (55.5")	1010 kg (2230 lb)				
1.50 m ³ (1.96 yd ³)	1.30 m ³ (1.70 yd ³)	1490 mm (58.7")	1610 mm (63.4")	1080 kg (2380 lb)				

※ : Standard bucket

 Applicable for materials with density of 2000 kgf/m³ (3370 lbf/yd³) or less

 Applicable for materials with density of 1600 kgf/m³ (2700 lbf/yd³) or less

 Applicable for materials with density of 1100 kgf/m³ (1850 lbf/yd³) or less

2) ROCK AND HEAVY DUTY BUCKET

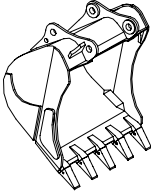
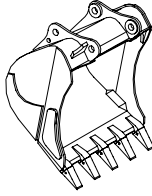
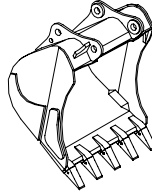
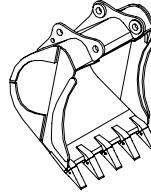
			
<p>◆ 1.07m³ SAE ◆ 1.15m³ SAE heaped bucket</p>	<p>◆ 1.27m³ SAE heaped bucket</p>	<p>◆ 1.46m³ SAE heaped bucket</p>	<p>○ 1.16m³ SAE heaped bucket</p>

Capacity		Width		Weight	Recommendation			
SAE heaped	CECE heaped	Without side cutter	With side cutter		5.85 m (19' 2") boom			
					2.1 m arm (6' 11")	2.5 m arm (8' 2")	3.05 m arm (10' 0")	3.6 m arm (11' 10")
◆ 1.07 m ³ (1.40 yd ³)	0.95 m ³ (1.24 yd ³)	1150 mm (45.3")	—	1120 kg (2470 lb)				
◆ 1.15 m ³ (1.50 yd ³)	1.00 m ³ (1.31 yd ³)	1210 mm (47.6")	—	1160 kg (2560 lb)				
◆ 1.27 m ³ (1.66 yd ³)	1.10 m ³ (1.44 yd ³)	1310 mm (51.6")	—	1240 kg (2730 lb)				
◆ 1.46 m ³ (1.91 yd ³)	1.28 m ³ (1.67 yd ³)	1460 mm (57.5")	—	1320 kg (2910 lb)				
○ 1.16 m ³ (1.52 yd ³)	1.00 m ³ (1.31 yd ³)	1340 mm (52.8")	—	1280 kg (2820 lb)				

◆ : Heavy duty bucket ○ : Rock-Heavy duty bucket

Applicable for materials with density of 2000 kgf/m³ (3370 lbf/yd³) or less

Applicable for materials with density of 1600 kgf/m³ (2700 lbf/yd³) or less

Applicable for materials with density of 1100 kgf/m³ (1850 lbf/yd³) or less

7. UNDERCARRIAGE

1) TRACKS

X-leg type center frame is integrally welded with reinforced box-section track frames. The design includes dry tracks, lubricated rollers, idlers, sprockets, hydraulic track adjusters with shock absorbing springs and assembled track-type tractor shoes with triple grousers.

2) TYPES OF SHOES

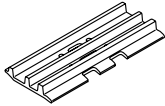
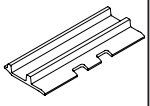
Model	Shapes		Triple grouser				Double grouser
							
R260LC-9A	Shoe width	mm (in)	600 (24)	700 (28)	800 (32)	900 (36)	-
	Operating weight	kg (lb)	25200 (55600)	25500 (56200)	25800 (56900)	26100 (57500)	-
	Ground pressure	kgf/cm ² (psi)	0.51 (7.25)	0.44 (6.26)	0.39 (5.55)	0.35 (4.98)	-
	Overall width	mm (ft-in)	3180 (10' 5")	3280 (10' 9")	3380 (11' 1")	3480 (11' 5")	-
R260NLC-9A	Shoe width	mm (in)	600 (24)	-	-	-	-
	Operating weight	kg (lb)	25100 (55300)	-	-	-	-
	Ground pressure	kgf/cm ² (psi)	0.51 (7.25)	-	-	-	-
	Overall width	mm (ft-in)	2980 (9' 9")	-	-	-	-
R260LC-9A HIGH WALKER	Shoe width	mm (in)	600 (24)	700 (28)	800 (32)	-	700 (28)
	Operating weight	kg (lb)	27450 (60520)	28020 (61770)	28400 (62610)	-	28620 (63100)
	Ground pressure	kgf/cm ² (psi)	0.53 (7.54)	0.46 (6.54)	0.41 (5.83)	-	0.47 (6.68)
	Overall width	mm (ft-in)	3180 (10' 5")	3280 (10' 9")	3380 (11' 1")	-	3280 (10' 9")

3) NUMBER OF ROLLERS AND SHOES ON EACH SIDE

Item	Quantity	
	R260LC-9A, R260NLC-9A	R260LC-9A HIGH WALKER
Carrier rollers	2 EA	2 EA
Track rollers	9 EA	9 EA
Track shoes	51 EA	48 EA

4) SELECTION OF TRACK SHOE

Suitable track shoes should be selected according to operating conditions.

Method of selecting shoes

Confirm the category from the list of applications in table 2, then use table 1 to select the shoe. Wide shoes (Categories B and C) have limitations on applications. Before using wide shoes, check the precautions, then investigate and study the operating conditions to confirm if these shoes are suitable.

Select the narrowest shoe possible to meet the required flotation and ground pressure. Application of wider shoes than recommendations will cause unexpected problem such as bending of shoes, crack of link, breakage of pin, loosening of shoe bolts and the other various problems.

※ Table 1

Track shoe	Specification	Category
600mm triple grouser	Standard	A
700mm triple grouser	Option	B
700mm double grouser ★1	Option	B
800mm triple grouser	Option	C
900mm triple grouser	Option	C

★1 : R260LC-9A HIGH WALKER ONLY

※ Table 2

Category	Applications	Precautions
A	Rocky ground, river beds, normal soil	<ul style="list-style-type: none"> Travel at low speed on rough ground with large obstacles such as boulders or fallen trees
B	Normal soil, soft ground	<ul style="list-style-type: none"> These shoes cannot be used on rough ground with large obstacles such as boulders or fallen trees Travel at high speed only on flat ground Travel slowly at low speed if it is impossible to avoid going over obstacles
C	Extremely, soft ground (Swampy ground)	<ul style="list-style-type: none"> Use the shoes only in the conditions that the machine sinks and it is impossible to use the shoes of category A or B These shoes cannot be used on rough ground with large obstacles such as boulders or fallen trees Travel at high speed only on flat ground Travel slowly at low speed if it is impossible to avoid going over obstacles

8. SPECIFICATIONS FOR MAJOR COMPONENTS

1) ENGINE

Item	Specification
Model	Cummins QSB6.7
Type	4-cycle turbocharged, charger air cooled diesel engine
Cooling method	Water cooling
Number of cylinders and arrangement	6 cylinders, in-line
Firing order	1-5-3-6-2-4
Combustion chamber type	Direct injection type
Cylinder bore × stroke	107 × 124 mm (4.2" × 4.9")
Piston displacement	6700 cc (409 cu in)
Compression ratio	17.3 : 1
Rated gross horse power (SAE J1995)	188 Hp at 1900 rpm (140 kW at 1900 rpm)
Maximum torque	82.5 kgf · m (597 lbf · ft) at 1500 rpm
Engine oil quantity	25 ℓ (6.6 U.S. gal)
Dry weight	519 kg (1144 lb)
High idling speed	1950+ 50 rpm
Low idling speed	850 ± 100 rpm
Rated fuel consumption	162 g/Hp · hr at 1900 rpm
Starting motor	Denso (24V-4.8 kW)
Alternator	Denso (24V-95A)
Battery	2 × 12V × 100 Ah

2) MAIN PUMP

Item	Specification
Type	Variable displacement tandem axis piston pumps
Capacity	2 × 117 cc/rev
Maximum pressure	350 kgf/cm ² (4980 psi) [380 kgf/cm ² (5400 psi)]
Rated oil flow	2 × 222 ℓ /min (58.7 U.S. gpm/ 48.8 U.K. gpm)
Rated speed	1900 rpm

[] : Power boost

3) GEAR PUMP

Item	Specification
Type	Fixed displacement gear pump single stage
Capacity	15 cc/rev
Maximum pressure	40 kgf/cm ² (570 psi)
Rated oil flow	28.5 ℓ /min (7.45 U.S. gpm / 6.27 U.K. gpm)

4) MAIN CONTROL VALVE

Item	Specification
Type	9 spools
Operating method	Hydraulic pilot system
Main relief valve pressure	350 kgf/cm ² (4980 psi) [380 kgf/cm ² (5400 psi)]
Overload relief valve pressure	400 kgf/cm ² (5690 psi)

[] : Power boost

5) SWING MOTOR

Item	Specification	
	Type 1	Type 2
Type	Axial piston motor	
Capacity	148.5 cc/rev	151 cc/rev
Relief pressure	300 kgf/cm ² (4270 psi)	
Braking system	Automatic, spring applied hydraulic released	
Braking torque	70 kgf · m (506 lbf · ft)	
Brake release pressure	21~26 kgf/cm ² (299~370 psi)	30~50 kgf/cm ² (427~711 psi)
Reduction gear type	2 - stage planetary	

※ Type 1 and 2 : See parts manual

6) TRAVEL MOTOR

Item	Specification	
	Type 1	Type 3
Type	Axial piston motor	
Relief pressure	350 kgf/cm ² (4980 psi)	
Capacity (max / min)	161.5/93.5 cc/rev	182.4/105.4 cc/rev
Reduction gear type	Planetary differential	
Braking system	Automatic, spring applied hydraulic released	
Brake release pressure	8.2 kgf/cm ² (117 psi)	14.7~18.3 kgf/cm ² (209~260 psi)
Braking torque	50 kgf · m (362 lbf · ft)	72 kgf · m (521 lbf · ft)

※ Type 1 and 3 : See parts manual

7) TRAVEL MOTOR (HIGH WALKER)

Item	Specification	
	Type 2	Type 4
Type	Axial piston motor	
Relief pressure	350 kgf/cm ² (4980 psi)	
Capacity (max / min)	282.6/156.9 cc/rev	154.8/88.5 cc/rev
Reduction gear type	Planetary differential	
Braking system	Automatic, spring applied hydraulic released	
Brake release pressure	14.8 kgf/cm ² (211 psi)	9 kgf/cm ² (128 psi)
Braking torque	100 kgf · m (723 lbf · ft)	40 kgf · m (289 lbf · ft)

※ Type 2 and 4 : See parts manual

8) CYLINDER

Item		Specification
Boom cylinder	Bore dia × Rod dia × Stroke	∅135 × ∅95 × 1345 mm
	Cushion	Extend only
Arm cylinder	Bore dia × Rod dia × Stroke	∅145 × ∅105 × 1620 mm
	Cushion	Extend and retract
Bucket cylinder	Bore dia × Rod dia × Stroke	∅130 × ∅90 × 1185 mm
	Cushion	Extend only

※ Discoloration of cylinder rod can occur when the friction reduction additive of lubrication oil spreads on the rod surface.

※ Discoloration does not cause any harmful effect on the cylinder performance.

9) SHOE

Item		Width	Ground pressure	Link quantity	Overall width
R260LC-9A	Standard	600 mm (24")	0.51 kgf/cm ² (7.25 psi)	51	3180 mm (10' 5")
	Option	700 mm (28")	0.44 kgf/cm ² (6.26 psi)	51	3280 mm (10' 9")
		800 mm (32")	0.39 kgf/cm ² (5.55 psi)	51	3380 mm (11' 1")
		900 mm (36")	0.35 kgf/cm ² (4.98 psi)	51	3480 mm (11' 5")
R260NLC-9A	Standard	600 mm (24")	0.51 kgf/cm ² (7.25 psi)	51	2980 mm (9' 9")
R260LC-9A HIGH WALKER	Standard	600 mm (24")	0.53 kgf/cm ² (7.54 psi)	48	3180 mm (10' 5")
	Option	700 mm (28")	0.46 kgf/cm ² (6.54 psi)	48	3280 mm (10' 9")
		800 mm (32")	0.41 kgf/cm ² (5.83 psi)	48	3380 mm (11' 1")
		★700 mm (28")	0.47 kgf/cm ² (6.68 psi)	48	3280 mm (10' 9")

★: Double grouser

10) BUCKET

Item		Capacity		Tooth quantity	Width	
		SAE heaped	CECE heaped		Without side cutter	With side cutter
R260LC-9A R260NLC-9A R260LC-9A H/WALKER	Standard	1.08 m ³ (1.41 yd ³)	0.95 m ³ (1.24 yd ³)	5	1130 mm (44.5")	1250 mm (49.2")
	Option	0.60 m ³ (0.78 yd ³)	0.55 m ³ (0.72 yd ³)	3	760 mm (29.9")	880 mm (34.6")
		0.79 m ³ (1.03 yd ³)	0.70 m ³ (0.92 yd ³)	3	890 mm (35.0")	1010 mm (39.8")
		1.03 m ³ (1.35 yd ³)	0.90 m ³ (1.18 yd ³)	4	1090 mm (42.9")	1210 mm (47.6")
		1.27 m ³ (1.66 yd ³)	1.10 m ³ (1.44 yd ³)	5	1290 mm (50.8")	1410 mm (55.5")
		◆1.07 m ³ (1.40 yd ³)	0.95 m ³ (1.24 yd ³)	5	1150 mm (45.3")	—
		◆1.15 m ³ (1.50 yd ³)	1.00 m ³ (1.31 yd ³)	5	1210 mm (47.6")	—
		◆1.27 m ³ (1.66 yd ³)	1.10 m ³ (1.44 yd ³)	5	1310 mm (51.6")	—
		◆1.46 m ³ (1.91 yd ³)	1.28 m ³ (1.67 yd ³)	6	1460 mm (57.5")	—
		⊙1.16 m ³ (1.52 yd ³)	1.00 m ³ (1.31 yd ³)	5	1340 mm (52.8")	—
		1.50 m ³ (1.96 yd ³)	1.30 m ³ (1.70 yd ³)	5	1490 mm (58.7")	1610 mm (63.4")

◆ : Heavy duty bucket

⊙ : Rock bucket

9. RECOMMENDED OILS

Use only oils listed below. Do not mix different brand oil.

Please use HYUNDAI genuine oil and grease.

Service point	Kind of fluid	Capacity ℓ (U.S. gal)	Ambient temperature °C (°F)							
			-50 (-58)	-30 (-22)	-20 (-4)	-10 (14)	0 (32)	10 (50)	20 (68)	30 (86)
Engine oil pan	Engine oil	23 (6.1)	★SAE 5W-40							
			SAE 30							
			SAE 10W							
			SAE 10W-30							
			SAE 15W-40							
Swing drive	Gear oil	6.0 (1.6)								
Final drive		6.0×2 (1.6×2)	★SAE 75W-90							
Final drive (H/W)		8.0×2 (2.1×2)	SAE 80W-90							
Hydraulic tank	Hydraulic oil	Tank; 165 (43.6)	★ISO VG 15							
			ISO VG 32							
		System; 285 (75.3)	ISO VG 46							
			ISO VG 68							
Fuel tank	Diesel fuel★ ¹	400 (106)	★ASTM D975 NO.1							
			ASTM D975 NO.2							
Fitting (grease nipple)	Grease	As required	★NLGI NO.1							
			NLGI NO.2							
Radiator (reservoir tank)	Mixture of antifreeze and water 50 : 50	40 (10.56)	Ethylene glycol base permanent type							
			★Ethylene glycol base permanent type (60 : 40)							

SAE : Society of Automotive Engineers

API : American Petroleum Institute

ISO : International Organization for Standardization

NLGI : National Lubricating Grease Institute

ASTM : American Society of Testing and Material

★¹ Ultra low sulfur diesel

- sulfur content ≤ 15 ppm

★ : Cold region

Russia, CIS, Mongolia