

GROUP 4 HYDRAULIC SYSTEM

HYDRAULIC COMPONENTS MOUNTING 1

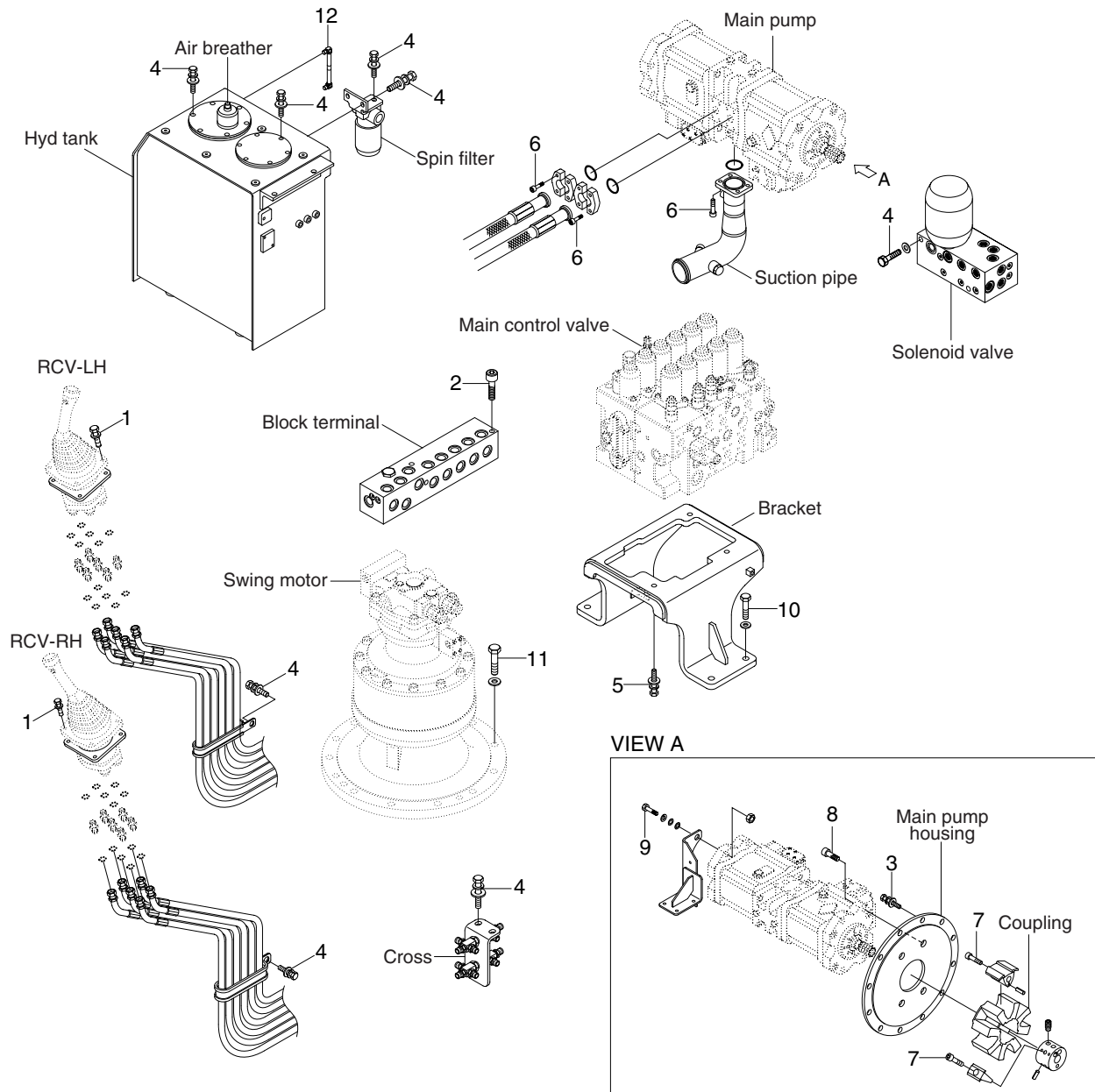

2609A9CM05

• Tightening torque

Item	Size	kgf · m	lbf · ft
1	M 6×1.0	1.05±0.2	7.6±1.45
2	M 8×1.25	2.5±0.5	18.1±3.6
3	M10×1.5	4.8±0.3	34.7±2.2
4	M10×1.5	6.9±1.4	49.9±10.1
5	M12×1.75	12.3±1.3	89±9.4
6	M12×1.75	12.8±3.0	92.6±21.7

Item	Size	kgf · m	lbf · ft
7	M18×2.5	32±1.0	231±7.2
8	M20×2.5	42±4.0	304±28.9
9	M20×2.5	46±5.1	333±36.9
10	M20×2.5	57.9±5.8	419±42
11	M24×3.0	97.8±10	707±72.3
22	Level gauge	1.2	8.7

HYDRAULIC COMPONENTS MOUNTING 2

Double acting attachment piping

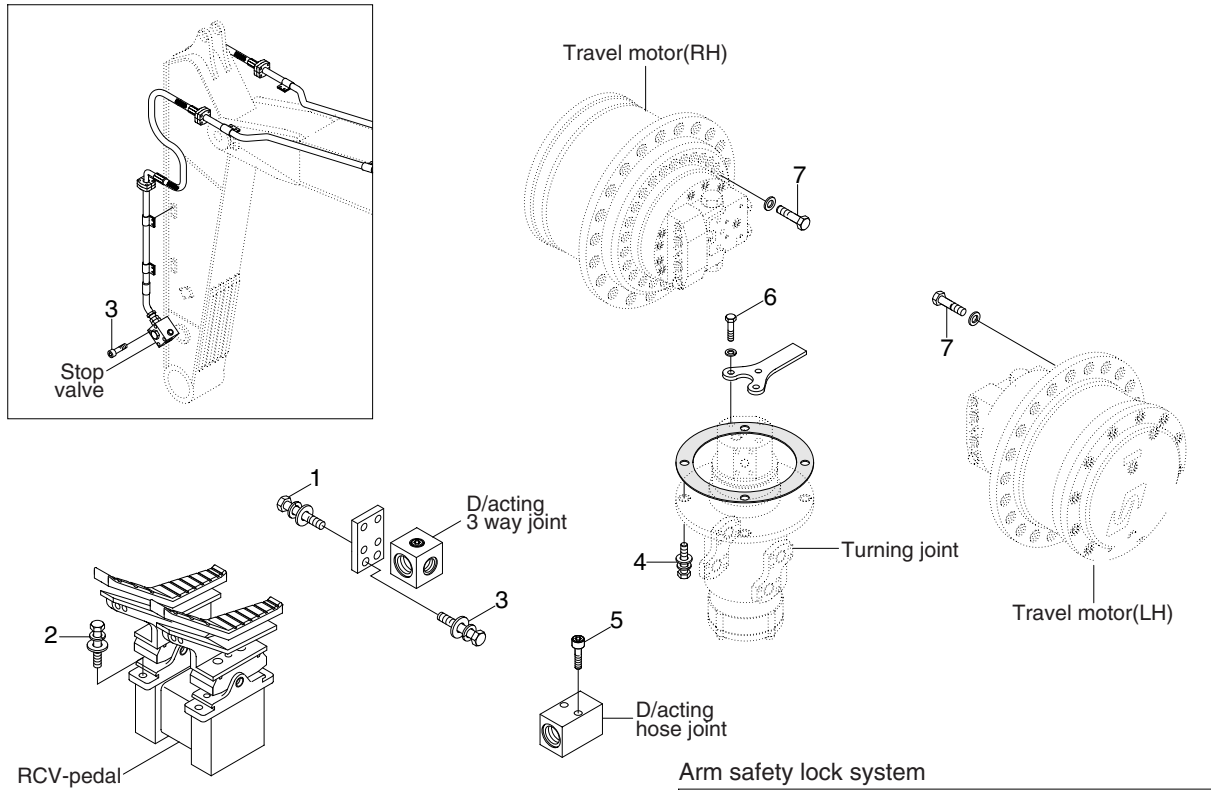

D/acting single pedal

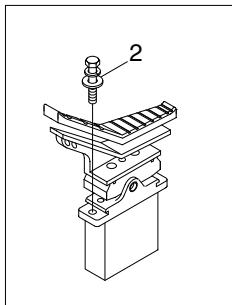

Boom safety lock system

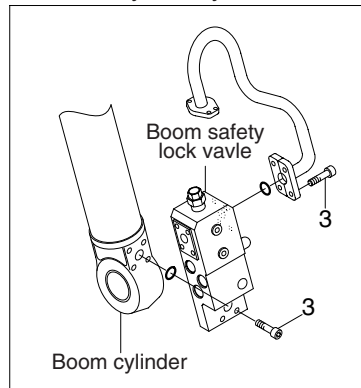

Arm safety lock system

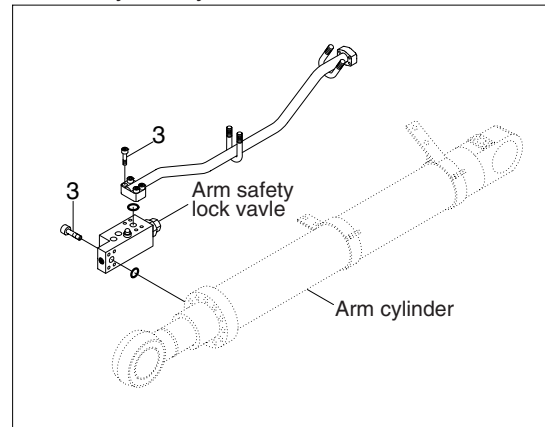

2609A9CM06

• Tightening torque

Item	Size	kgf · m	lbf · ft
1	M 8 × 1.25	2.5 ± 0.5	18.1 ± 3.6
2	M 10 × 1.5	6.9 ± 1.4	49.9 ± 10.1
3	M 12 × 1.75	9.4 ± 1.0	68 ± 7.2
4	M 12 × 1.75	12.0 ± 1.3	86.8 ± 9.4

Item	Size	kgf · m	lbf · ft
5	M 12 × 1.75	14.7 ± 2.2	106 ± 15.9
6	M 14 × 2.0	19.6 ± 2.9	142 ± 21.0
7	M 16 × 2.0	23.0 ± 2.5	166 ± 18.1
-	-	-	-

HYDRAULIC COMPONENTS MOUNTING 3

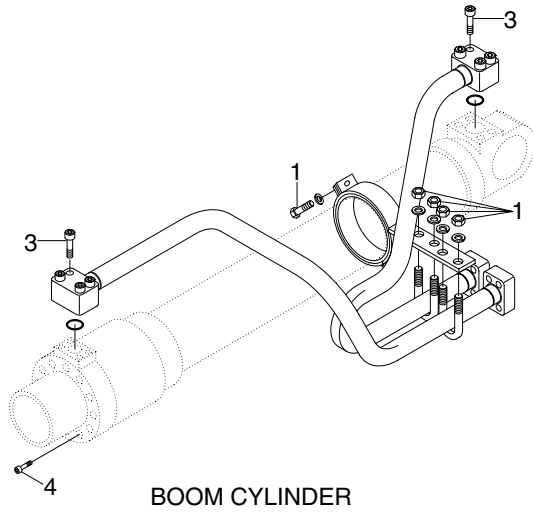

Solenoid valve

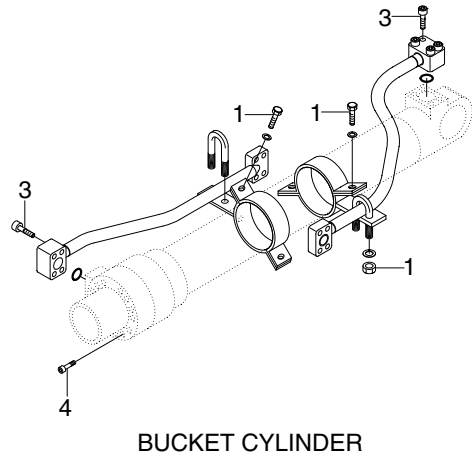
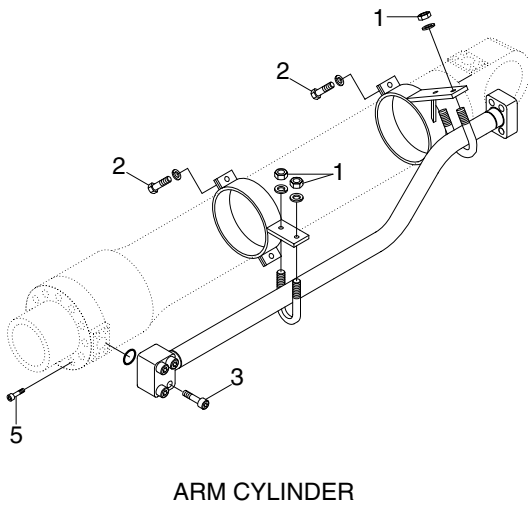
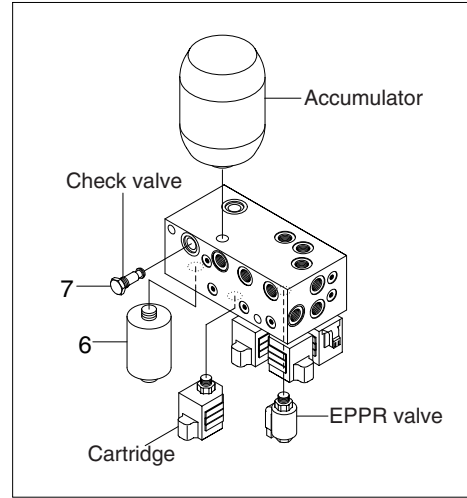

2609A9CM07

· Tightening torque

Item	Size	kgf · m	lbf · ft
1	M10×1.5	3.2±0.3	23.1±2.2
2	M12×1.75	5.5±0.6	39.8±4.3
3	M12×1.75	9.4±1.0	68.0±7.2
4	M18×2.5	32±3.0	232±21.7

Item	Size	kgf · m	lbf · ft
5	M20×2.5	46±5	333±36.2
6	Line filter	2.5	18.0
7	Check valve	4.0	28.9
-	-	-	-