

GROUP 2 SPECIFICATIONS

1. MAJOR COMPONENT

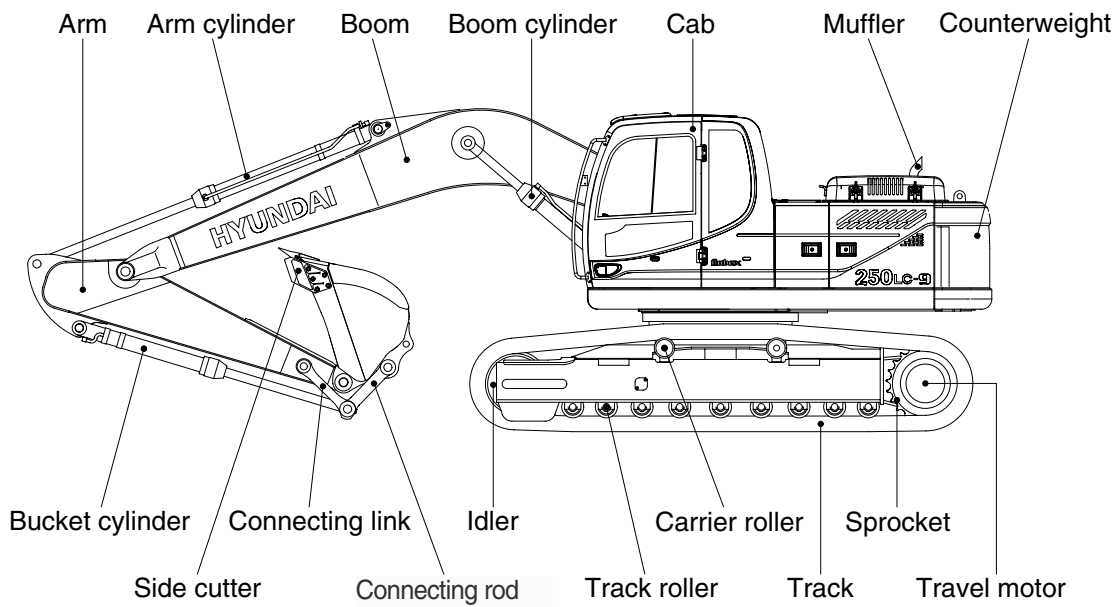
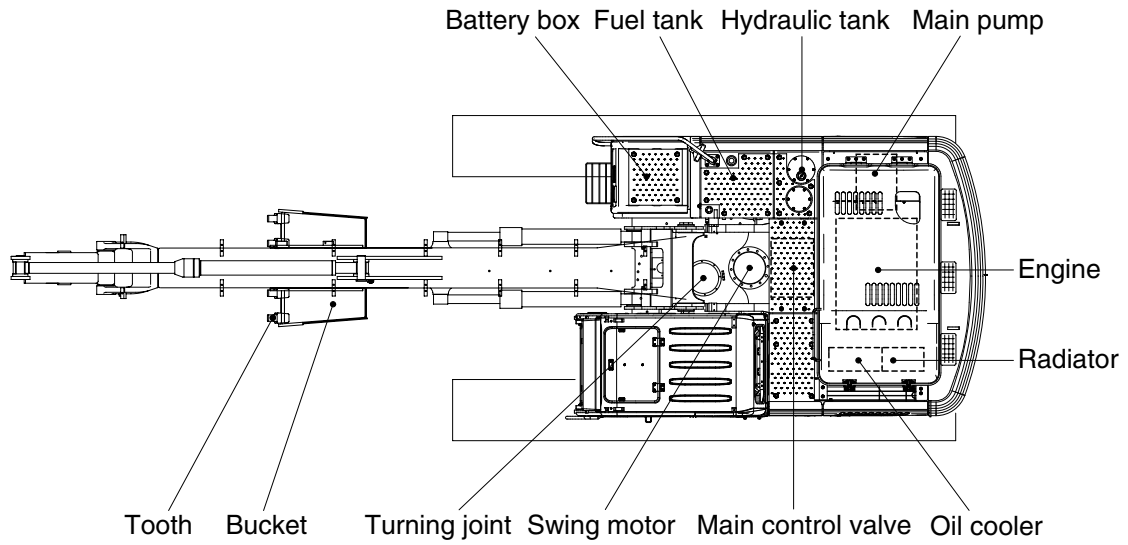

25092SP01

2. SPECIFICATIONS

1) R250LC-9

· 5.85 m (19' 2") BOOM and 3.05 m (10' 0") ARM

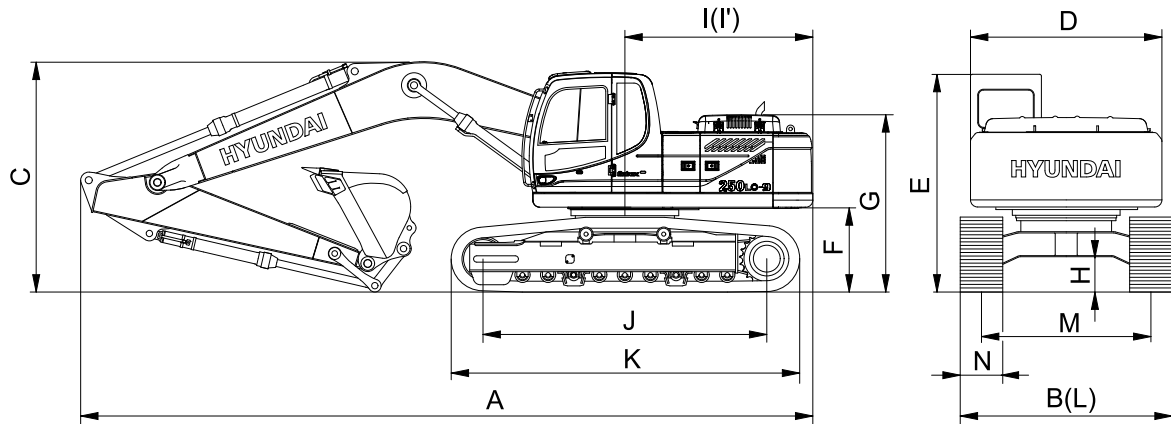

25092SP02

Description		Unit	Specification
Operating weight		kg (lb)	25200 (55560)
Bucket capacity (SAE heaped), standard		m ³ (yd ³)	1.08 (1.41)
Overall length	A	mm (ft-in)	9920 (32' 7")
Overall width, with 600mm shoe	B		3180 (10' 5")
Overall height	C		3220 (10' 7")
Superstructure width	D		2840 (9' 4")
Overall height of cab	E		2990 (9' 10")
Ground clearance of counterweight	F		1115 (3' 8")
Engine cover height	G		2427 (7' 12")
Minimum ground clearance	H		480 (1' 7")
Rear-end distance	I		2870 (9' 5")
Rear-end swing radius	I'		2975 (9' 9")
Distance between tumblers	J		3830 (12' 7")
Undercarriage length	K		4640 (15' 3")
Undercarriage width	L		3180 (10' 5")
Track gauge	M		2580 (8' 6")
Track shoe width, standard	N		600 (24")
Travel speed (low/high)			km/hr (mph)
Swing speed		rpm	12
Gradeability		Degree (%)	35 (70)
Ground pressure (600 mm shoe)		kgf/cm ² (psi)	0.51 (7.25)
Max traction force		kg (lb)	21600 (47600)

2) R250NLC-9

· 5.85 m (19' 2") BOOM and 3.05 m (10' 0") ARM

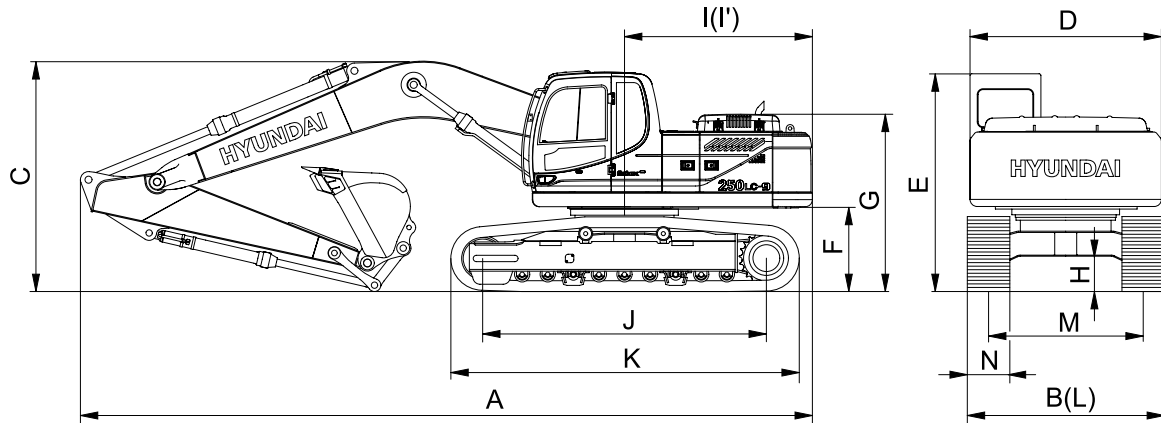

25092SP04

Description		Unit	Specification
Operating weight		kg (lb)	25100 (55300)
Bucket capacity (SAE heaped), standard		m ³ (yd ³)	1.08 (1.41)
Overall length	A	mm (ft-in)	9920 (32' 7")
Overall width, with 600 mm shoe	B		2980 (9' 9")
Overall height	C		3220 (10' 7")
Superstructure width	D		2840 (9' 4")
Overall height of cab	E		2990 (9' 10")
Ground clearance of counterweight	F		1115 (3' 8")
Engine cover height	G		2427 (7' 12")
Minimum ground clearance	H		480 (1' 7")
Rear-end distance	I		2870 (9' 5")
Rear-end swing radius	I'		2975 (9' 9")
Distance between tumbler	J		3830 (12' 7")
Undercarriage length	K		4640 (15' 3")
Undercarriage width	L		2980 (9' 9")
Track gauge	M		2380 (7' 10")
Track shoe width, standard	N		600 (24")
Travel speed (low/high)			km/hr (mph)
Swing speed		rpm	12
Gradeability		Degree (%)	35 (70)
Ground pressure (600 mm shoe)		kgf/cm ² (psi)	0.51 (7.25)
Max traction force		kg (lb)	21600 (47600)

3) R250LC-9 HIGH WALKER

· 5.85 m (19' 2") BOOM and 3.05 m (10' 0") ARM

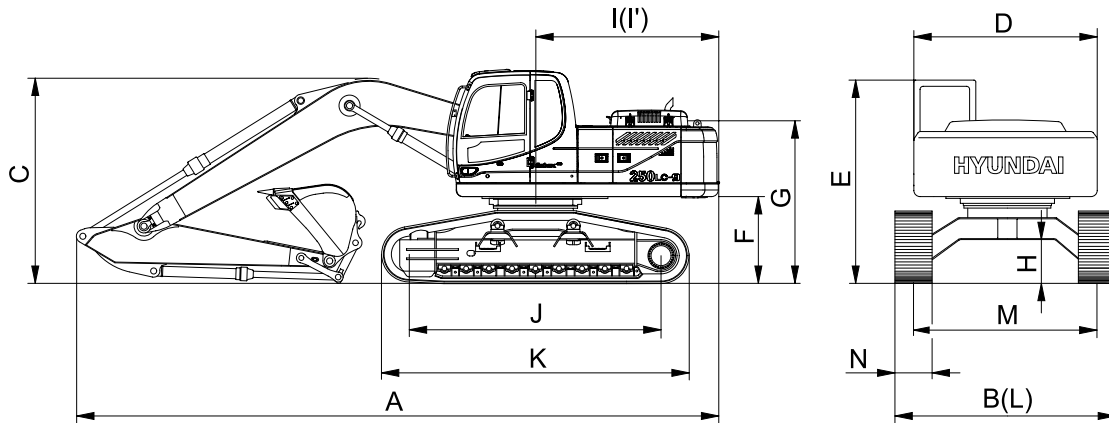

25092SP05

Description		Unit	Specification
Operating weight		kg (lb)	27450 (60520)
Bucket capacity (SAE heaped), standard		m ³ (yd ³)	1.08 (1.41)
Overall length	A	mm (ft-in)	9760 (32' 0")
Overall width, with 600 mm shoe	B		3390 (11' 1")
Overall height	C		3240 (10' 8")
Superstructure width	D		2840 (9' 4")
Overall height of cab	E		3345 (11' 0")
Ground clearance of counterweight	F		1470 (4' 10")
Engine cover height	G		2782 (9' 2")
Minimum ground clearance	H		765 (2' 6")
Rear-end distance	I		2975 (9' 9")
Rear-end swing radius	I'		2870 (9' 5")
Distance between tumbler	J		4030 (13' 3")
Undercarriage length	K		4940 (16' 2")
Undercarriage width	L		3390 (11' 1")
Track gauge	M		2790 (9' 2")
Track shoe width, standard	N		600 (24")
Travel speed (low/high)			km/hr (mph)
Swing speed		rpm	12
Gradeability		Degree (%)	35 (70)
Ground pressure (600 mm shoe)		kgf/cm ² (psi)	0.53 (7.54)
Max traction force		kg (lb)	21600 (47600)

3. WORKING RANGE

1) R250LC-9, R250NLC-9 [5.85 m (19' 2") BOOM]

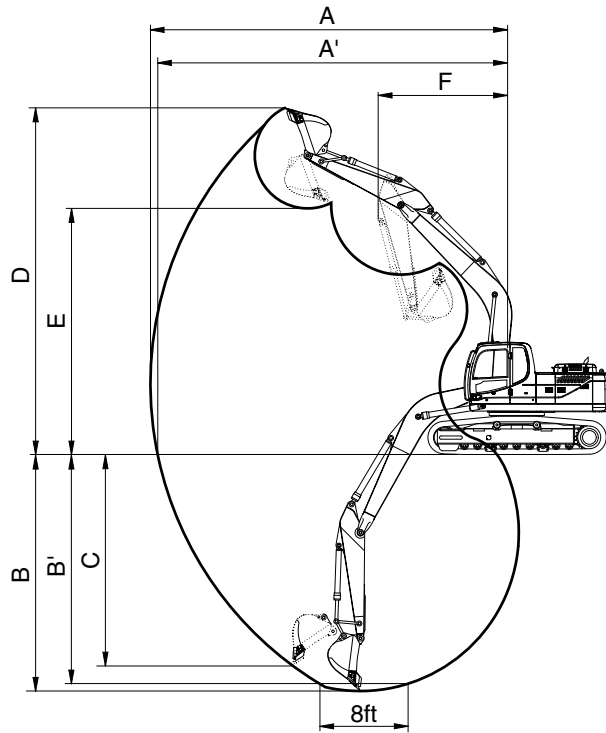

21092SP03

Description		2.10m (6' 11") Arm	2.50m (8' 2") Arm	※3.05m (10' 0") Arm	3.60m (11' 10") Arm
Max digging reach	A	9550 mm (31' 4")	9870 mm (32' 5")	10360 mm (34' 0")	10870 mm (35' 8")
Max digging reach on ground	A'	9360 mm (30' 9")	9680 mm (31' 9")	10190 mm (33' 5")	10700 mm (35' 1")
Max digging depth	B	6050 mm (19'10")	6450 mm (21' 2")	7000 mm (23' 0")	7550 mm (24' 9")
Max digging depth (8 ft level)	B'	5840 mm (19' 2")	6260 mm (20' 6")	6830 mm (22' 5")	7400 mm (24' 3")
Max vertical wall digging depth	C	5480 mm (18' 0")	5640 mm (18' 6")	6150 mm (20' 2")	6830 mm (22' 5")
Max digging height	D	9450 mm (31' 0")	9460 mm (31' 0")	9670 mm (31' 9")	9920 mm (32' 7")
Max dumping height	E	6360 mm (20'10")	6420 mm (21' 1")	6630 mm (21' 9")	6860 mm (22' 6")
Min swing radius	F	4420 mm (14' 6")	4200 mm (13' 9")	3980 mm (13' 1")	3900 mm (12' 10")
Bucket digging force	SAE	154 [167.2] kN	154 [167.2] kN	154 [167.2] kN	154 [167.2] kN
		15700 [17080] kgf	15700 [17080] kgf	16000 [17080] kgf	15700 [17080] kgf
		34610 [37580] lbf	34610 [37580] lbf	35270 [37580] lbf	34610 [37580] lbf
	ISO	175.5 [190.6] kN	175.5 [190.6] kN	175.5 [190.6] kN	175.5 [190.6] kN
		17900 [19430] kgf	17900 [19430] kgf	17900 [19430] kgf	17900 [19430] kgf
		39460 [42840] lbf	39460 [42840] lbf	39460 [42840] lbf	39460 [42840] lbf
Arm digging force	SAE	134.4 [145.9] kN	128.5 [139.5] kN	114.7 [124.6] kN	103.0 [111.8] kN
		13700 [14870] kgf	13100 [14220] kgf	11700 [12700] kgf	10500 [11400] kgf
		30200 [32790] lbf	28880 [31360] lbf	25790 [28000] lbf	23150 [25130] lbf
	ISO	139.3 [151.2] kN	133.4 [144.8] kN	118.7 [128.8] kN	106.9 [116.1] kN
		14200 [15420] kgf	13600 [14770] kgf	12100 [13100] kgf	10900 [11830] kgf
		31310 [33990] lbf	29980 [32550] lbf	26680 [28970] lbf	24030 [26090] lbf

[] : Power boost ※ : STD

2) R250LC-9 HIGH WALKER [5.85 m (19' 2") BOOM]

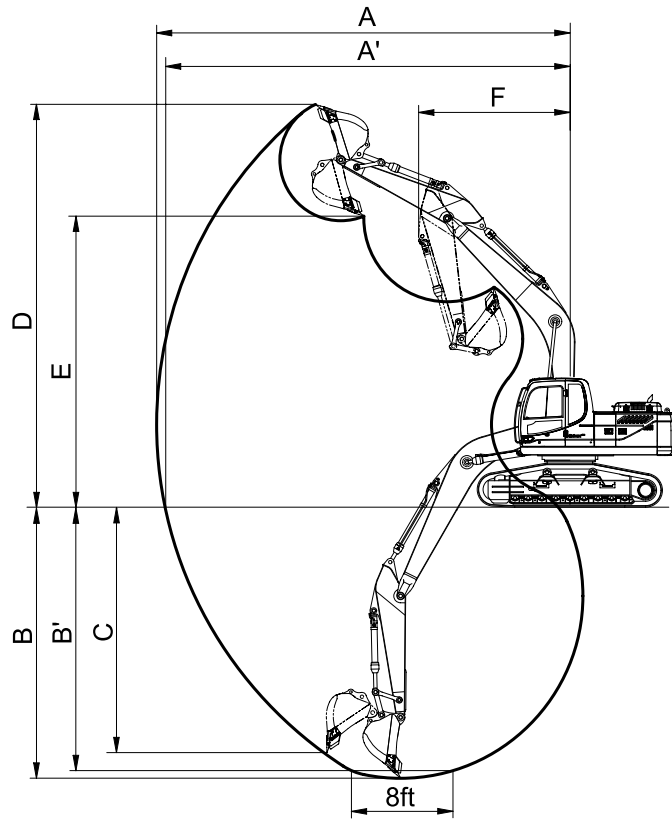

25092SP09

Description		2.10m (6' 11") Arm	2.50m (8' 2") Arm	※3.05m (10' 0") Arm	3.60m (11' 10") Arm
Max digging reach	A	9550 mm (31' 4")	9870 mm (32' 5")	10360 mm (34' 0")	10870 mm (35' 8")
Max digging reach on ground	A'	9280 mm (30' 5")	9160 mm (31' 6")	10110 mm (33' 2")	10360 mm (34' 11")
Max digging depth	B	5680 mm (18' 8")	6080 mm (19' 11")	6630 mm (21' 9")	7180 mm (23' 7")
Max digging depth (8 ft level)	B'	5470 mm (17' 11")	5890 mm (19' 4")	6460 mm (21' 2")	7030 mm (23' 1")
Max vertical wall digging depth	C	5120 mm (16' 10")	5300 mm (17' 5")	5790 mm (19' 0")	6470 mm (21' 3")
Max digging height	D	9820 mm (32' 3")	9840 mm (32' 3")	10040 mm (32' 11")	10280 mm (33' 9")
Max dumping height	E	6730 mm (22' 1")	6790 mm (22' 3")	7000 mm (23' 0")	7220 mm (23' 8")
Min swing radius	F	4140 mm (13' 7")	4030 mm (13' 3")	3940 mm (12' 11")	3900 mm (12' 10")
Bucket digging force	SAE	154 [167.2] kN	154 [167.2] kN	154 [167.2] kN	154 [167.2] kN
		15700 [17080] kgf	15700 [17080] kgf	15700 [17080] kgf	15700 [17080] kgf
		34610 [37580] lbf	34610 [37580] lbf	34610 [37580] lbf	34610 [37580] lbf
	ISO	175.5 [190.6] kN	175.5 [190.6] kN	175.5 [190.6] kN	175.5 [190.6] kN
		17900 [19430] kgf	17900 [19430] kgf	17900 [19430] kgf	17900 [19430] kgf
		39460 [42840] lbf	39460 [42840] lbf	39460 [42840] lbf	39460 [42840] lbf
Arm crowd force	SAE	134.4 [145.9] kN	128.5 [139.5] kN	114.7 [124.6] kN	103.0 [111.8] kN
		13700 [14870] kgf	13100 [14220] kgf	11700 [12700] kgf	10500 [11400] kgf
		30200 [32790] lbf	28880 [31360] lbf	25790 [28000] lbf	23150 [25130] lbf
	ISO	139.3 [151.2] kN	133.4 [144.8] kN	118.7 [128.8] kN	106.9 [116.1] kN
		14200 [15420] kgf	13600 [14770] kgf	12100 [13100] kgf	10900 [11830] kgf
		31310 [33990] lbf	29980 [32550] lbf	26680 [28970] lbf	24030 [26090] lbf

[] : Power boost ※ : STD

4. WEIGHT

1) R250LC-9, R250NLC-9,

Item	R250LC-9		R250NLC-9	
	kg	lb	kg	lb
Upperstructure assembly	10500	23150	←	←
Main frame weld assembly	2360	5200	←	←
Engine assembly	560	1240	←	←
Main pump assembly	136	300	←	←
Main control valve assembly	220	485	←	←
Swing motor assembly	345	760	←	←
Hydraulic oil tank assembly	220	485	←	←
Fuel tank assembly	200	440	←	←
Counterweight	4600	10140	←	←
Cab assembly	310	680	←	←
Lower chassis assembly	9750	21500	9810	21630
Track frame weld assembly	3070	6770	2980	6570
Swing bearing	280	800	←	←
Travel motor assembly	276	608	←	←
Turning joint	53	117	←	←
Track recoil spring	140	309	←	←
Idler	160	353	←	←
Carrier roller	20	45	←	←
Track roller	40	88	←	←
Track-chain assembly (600 mm standard triple grouser shoe)	1500	3310	←	←
Front attachment assembly (5.85 m boom, 3.05 m arm, 1.08 m ³ SAE heaped bucket)	4950	10910	←	←
5.85 m boom assembly	1940	4280	←	←
3.05 m arm assembly	1020	2250	←	←
1.08 m ³ SAE heaped bucket	910	2010	←	←
Boom cylinder assembly	240	530	←	←
Arm cylinder assembly	340	750	←	←
Bucket cylinder assembly	220	490	←	←
Bucket control rod assembly	110	240	←	←

2) R250LC-9 HIGH WALKER

Item	R250LC-9 HIGH WALKER	
	kg	lb
Upperstructure assembly	10500	23150
Main frame weld assembly	2360	5200
Engine assembly	560	1240
Main pump assembly	136	300
Main control valve assembly	220	485
Swing motor assembly	345	760
Hydraulic oil tank assembly	220	485
Fuel tank assembly	200	440
Counterweight	4600	10140
Cab assembly	310	680
Lower chassis assembly	12000	26460
Track frame weld assembly	5280	11640
Swing bearing	360	800
Travel motor assembly	276	608
Turning joint	53	117
Track recoil spring	200	440
Idler	250	550
Carrier roller	55	120
Track roller	55	120
Track-chain assembly (600 mm standard triple grouser shoe)	1860	4100
Front attachment assembly (5.85 m boom, 3.05 m arm, 1.08 m ³ SAE heaped bucket)	4950	10910
5.85 m boom assembly	1940	4280
3.05 m arm assembly	1020	2250
1.08 m ³ SAE heaped bucket	910	2010
Boom cylinder assembly	240	530
Arm cylinder assembly	340	750
Bucket cylinder assembly	220	490
Bucket control rod assembly	110	240











5. LIFTING CAPACITIES

1) R250LC-9

(1) 5.85 m (19' 2") boom, 2.10 m (6' 11") arm equipped with 1.08 m³ (SAE heaped) bucket and 600 mm (24") triple grouser shoe and 4600 kg (10140 lb) counterweight.













·  : Rating over-front

·  : Rating over-side or 360 degree













Load point height		Load radius								At max. reach		
		3.0 m (10 ft)		4.5 m (15 ft)		6.0 m (20 ft)		7.5 m (25 ft)		Capacity		Reach
												m (ft)
6.0 m (20 ft)	kg lb					*5790 *12760	*5790 *12760			5220 11510	3200 7050	8.32 (27.3)
4.5 m (15 ft)	kg lb			*7810 *17220	*7810 *17220	*6510 *14350	5570 12280	*6000 *13230	3690 8140	4520 9960	2710 5970	8.91 (29.2)
3.0 m (10 ft)	kg lb			*10260 *22620	8200 18080	*7600 *16760	5190 11440	5900 13010	3550 7830	4210 9280	2480 5470	9.17 (30.1)
1.5 m (5 ft)	kg lb			*12300 *27120	7520 16580	8250 18190	4850 10690	5720 12610	3380 7450	4170 9190	2430 5360	9.14 (30.0)
Ground Line	kg lb			13110 28900	7250 15980	8010 17660	4640 10230	5600 12350	3270 7210	4410 9720	2580 5690	8.80 (28.9)
-1.5 m (-5 ft)	kg lb	*15460 *34080	15160 33420	13090 28860	7230 15940	7940 17500	4580 10100			5060 11160	2990 6590	8.13 (26.7)
-3.0 m (-10 ft)	kg lb	*17100 *37700	15470 34110	*12090 *26650	7390 16290	8050 17750	4680 10320			*6290 *13870	3980 8770	6.98 (22.9)
-4.5 m (-15 ft)	kg lb	*13360 *29450	*13360 *29450	*9460 *20860	7790 17170							

- Note
1. Lifting capacity are based on SAE J1097 and ISO 10567.
 2. Lifting capacity of the ROBEX series does not exceed 75% of tipping load with the machine on firm, level ground or 87% of full hydraulic capacity.
 3. The load point is a hook (standard equipment) located on the back of the bucket.
 4. *indicates load limited by hydraulic capacity.















(2) 5.85 m (19' 2") boom, 2.50 m (8' 2") arm equipped with 1.08 m³ (SAE heaped) bucket and 600 mm (24") triple grouser shoe and 4600 kg (10140 lb) counterweight.

Load point height		Load radius										At max. reach		
		1.5 m (5 ft)		3.0 m (10 ft)		4.5 m (15 ft)		6.0 m (20ft)		7.5 m (25ft)		Capacity		Reach
														m (ft)
6.0 m (20 ft)	kg lb											4900 10800	3000 6610	8.67 (28.4)
4.5 m (15 ft)	kg lb							*6070 *13380	5670 12500	*5630 *12410	3770 8310	4280 9440	2550 5620	9.23 (30.3)
3.0 m (10 ft)	kg lb					*9550 *21050	8410 18540	*7210 *15900	5280 11640	5950 13120	3590 7910	3990 8800	2340 5160	9.48 (31.1)
1.5 m (5 ft)	kg lb					*11790 *25990	7650 16870	8310 18320	4910 10820	5750 12680	3410 7520	3950 8170	2290 5050	9.45 (31.0)
Ground Line	kg lb					*12990 *28640	7280 16050	8030 17700	4660 10270	5600 12350	3270 7210	4150 9150	2410 5310	9.13 (30.0)
-1.5 m (-5 ft)	kg lb			*15100 *33290	14960 32980	13050 28770	7190 15850	7910 17440	4560 10050	5550 12240	3220 7100	4690 10340	2750 6060	8.49 (27.9)
-3.0 m (-10 ft)	kg lb	*16360 *36070	*16360 *36070	*18120 *39950	15250 33620	*12470 *27490	7300 16090	7970 17570	4610 10160			5940 13100	3550 7830	7.41 (24.3)
-4.5 m (-15 ft)	kg lb			*14860 *32760	*14860 *32760	*10430 *22990	7620 16800							

(3) 5.85 m (19' 2") boom, 3.05 m (10' 0") arm equipped with 1.08 m³ (SAE heaped) bucket and 600 mm (24") triple grouser shoe and 4600 kg (10140 lb) counterweight.

Load point height		Load radius										At max. reach		
		1.5 m (5 ft)		3.0 m (10 ft)		4.5 m (15 ft)		6.0 m (20ft)		7.5 m (25ft)		Capacity		Reach
														m (ft)
6.0 m (20 ft)	kg lb									*3700 *8160	*3700 *8160	4400 9700	2660 5860	9.22 (30.2)
4.5 m (15 ft)	kg lb							*5350 *11790	*5350 *11790	*5060 *11160	3830 8440	3880 8550	2280 5030	9.74 (32.0)
3.0 m (10 ft)	kg lb			*13640 *30070	*13640 *30070	*8400 *18520	*8400 *18520	*6540 *14420	5360 11820	*5660 *12480	3620 7980	3630 8000	2090 4610	9.98 (32.7)
1.5 m (5 ft)	kg lb			*9450 *20830	*9450 *20830	*10870 *23960	7800 17200	*7820 *17240	4950 10910	5750 12680	3400 7500	3580 7890	2040 4500	9.95 (32.6)
Ground Line	kg lb			*10570 *23300	*10570 *23300	*12490 *27540	7280 16050	8010 17660	4640 10230	5560 12260	3230 7120	3730 8220	2130 4700	9.65 (31.7)
-1.5 m (-5 ft)	kg lb	*9940 *21910	*9940 *21910	*13870 *30580	*13870 *30580	12930 28510	7090 15630	7830 17260	4480 9880	5460 12040	3140 6920	4150 9150	2390 5270	9.05 (29.7)
-3.0 m (-10 ft)	kg lb	*13540 *29850	*13540 *29850	*18430 *40630	14860 32760	*12780 *28180	7110 15670	7820 17240	4470 9850			5080 11200	2980 6570	8.06 (26.4)
-4.5 m (-15 ft)	kg lb	*17830 *39310	*17830 *39310	*16580 *36550	15340 33820	*11360 *25040	7340 16180	8020 17680	4640 10230			*5940 *13100	4480 9880	6.48 (21.3)

(4) 5.85 m (19' 2") boom, 3.60 m (11' 10") arm equipped with 1.08 m³ (SAE heaped) bucket and 600 mm (24") triple grouser shoe and 4600 kg (10140 lb) counterweight.











Load point height		Load radius												At max. reach		
		1.5 m (5 ft)		3.0 m (10 ft)		4.5 m (15 ft)		6.0 m (20 ft)		7.5 m (25 ft)		9.0 m (30 ft)		Capacity		Reach
																
6.0 m (20 ft)	kg lb									*3930 *8660	*3930 *8660			3960 8730	2360 5200	9.77 (32.1)
4.5 m (15 ft)	kg lb									*4530 *9990	3890 8580	*2500 *5510	*2500 *5510	3530 7780	2040 4500	10.27 (33.7)
3.0 m (10 ft)	kg lb						*5890 *12990	5490 12100	*5190 *11440	3670 8090	*3590 *7910	2550 5620	3310 7300	1870 4120	10.49 (34.4)	
1.5 m (5 ft)	kg lb			*12610 *27800	*12610 *27800	*9960 *21960	8040 17730	*7260 *16010	5040 11110	5790 12760	3430 7560	4210 9280	2430 5360	3260 7190	1820 4010	10.46 (34.3)
Ground Line	kg lb			*11020 *24290	*11020 *24290	*11930 *26300	7390 16290	8070 17790	4680 10320	5570 12280	3230 7120	4090 9020	2320 5110	3380 7450	1890 4170	10.18 (33.4)
-1.5 m (-5 ft)	kg lb	*9010 *19860	*9010 *19860	*13200 *29100	*13200 *29100	*12900 *28440	7090 15630	7830 17260	4470 9850	5430 11970	3100 6830			3710 8180	2100 4630	9.62 (31.6)
-3.0 m (-10 ft)	kg lb	*12120 *26720	*12120 *26720	*16820 *37080	14680 32360	12880 28400	7040 15520	7750 17090	4400 9700	5390 11880	3070 6770			4420 9740	2550 5620	8.71 (28.6)
-4.5 m (-15 ft)	kg lb	*15830 *34900	*15830 *34900	*17940 *39550	15050 33180	*12020 *26500	7180 15830	7850 17310	4490 9900					*5790 *12760	3580 7890	7.30 (24.0)

2) R250NLC-9

(1) 5.85 m (19' 2") boom, 2.10 m (6' 11") arm equipped with 1.08 m³ (SAE heaped) bucket and 600 mm (24") triple grouser shoe and 4600 kg (10140 lb) counterweight.

·  : Rating over-front

·  : Rating over-side or 360 degree

Load point height		Load radius								At max. reach		
		3.0 m (10 ft)		4.5 m (15 ft)		6.0 m (20 ft)		7.5 m (25 ft)		Capacity		Reach m (ft)
												
6.0 m (20 ft)	kg lb					*5790 *12760	5290 11660			5200 11460	2870 6330	8.32 (27.3)
4.5 m (15 ft)	kg lb			*7810 *17220	*7810 *17220	*6510 *14350	5030 11090	*6000 *13230	3310 7300	4500 9920	2410 5310	8.91 (29.2)
3.0 m (10 ft)	kg lb			*10260 *22620	7330 16160	*7600 *16760	4660 10270	5870 12940	3170 6990	4190 9240	2190 4830	9.17 (30.1)
1.5 m (5 ft)	kg lb			*12300 *27120	6670 14700	8210 18100	4330 9550	5690 12540	3010 6640	4150 9150	2150 4740	9.14 (30.0)
Ground Line	kg lb			13050 28770	6410 14130	7970 17570	4120 9080	5570 12280	2900 6390	4390 9680	2280 5030	8.80 (28.9)
-1.5 m (-5 ft)	kg lb	*15460 *34080	13120 28920	13030 28730	6390 14090	7900 17420	4060 8950			5040 11110	2660 5860	8.13 (26.7)
-3.0 m (-10 ft)	kg lb	*17100 *37700	13420 29590	*12090 *26650	6540 14420	8020 17680	4160 9170			*6290 *13870	3560 7850	6.98 (22.9)
-4.5 m (-15 ft)	kg lb	*13360 *29450	*13360 *29450	*9460 *20860	6930 15280							

- Note
1. Lifting capacity are based on SAE J1097 and ISO 10567.
 2. Lifting capacity of the ROBEX series does not exceed 75% of tipping load with the machine on firm, level ground or 87% of full hydraulic capacity.
 3. The load point is a hook located on the back of the bucket.
 4. * indicates load limited by hydraulic capacity.















(2) 5.85 m (19' 2") boom, 2.50 m (8' 2") arm equipped with 1.08 m³ (SAE heaped) bucket and 600 mm (24") triple grouser shoe and 4600 kg (10140 lb) counterweight.

Load point height		Load radius										At max. reach		
		1.5 m (5 ft)		3.0 m (10 ft)		4.5 m (15 ft)		6.0 m (20ft)		7.5 m (25ft)		Capacity		Reach
														m (ft)
6.0 m (20 ft)	kg lb											4880 10760	2680 5910	8.67 (28.4)
4.5 m (15 ft)	kg lb							*6070 *13380	5130 11310	*5630 *12410	3380 7450	4260 9390	2270 5000	9.23 (30.3)
3.0 m (10 ft)	kg lb					*9550 *21050	7530 16600	*7210 *15900	4750 10470	5920 13050	3210 7080	3970 8750	2070 4560	9.48 (31.3)
1.5 m (5 ft)	kg lb					*11790 *25990	6790 14970	8270 18230	4380 9660	5720 12610	3030 6680	3930 8660	2020 4450	9.45 (31.0)
Ground Line	kg lb					*12990 *28640	6440 14200	7990 17610	4140 9130	5570 12280	2900 6390	4130 9110	2120 4670	9.13 (30.0)
-1.5 m (-5 ft)	kg lb			*15100 *33290	12930 28510	12990 28640	6350 14000	7880 17370	4040 8910	5520 12170	2850 6280	4670 10300	2440 5380	8.49 (27.9)
-3.0 m (-10 ft)	kg lb	*16360 *36070	*16360 *36070	*18120 *39950	13210 29120	*12470 *27490	6450 14220	7940 17500	4090 9020			5910 13030	3170 6990	7.41 (24.3)
-4.5 m (-15 ft)	kg lb			*14860 *32760	13750 30310	*10430 *22990	6760 14900							

(3) 5.85 m (19' 2") boom, 3.05 m (10' 0") arm equipped with 1.08 m³ (SAE heaped) bucket and 600 mm (24") triple grouser shoe and 4600 kg (10140 lb) counterweight.

Load point height		Load radius										At max. reach		
		1.5 m (5 ft)		3.0 m (10 ft)		4.5 m (15 ft)		6.0 m (20ft)		7.5 m (25ft)		Capacity		Reach
														m (ft)
6.0 m (20 ft)	kg lb									*3700 *8160	3570 7870	4380 9660	2370 5220	9.22 (30.2)
4.5 m (15 ft)	kg lb							*5350 *11790	5230 11530	*5060 *11160	3440 7580	3860 8510	2020 4450	9.74 (32.0)
3.0 m (10 ft)	kg lb			*13640 *30070	*13640 *30070	*8400 *18520	7780 17150	*6540 *14420	4830 10650	*5660 *12480	3240 7140	3610 7960	1840 4060	9.98 (32.7)
1.5 m (5 ft)	kg lb			*9450 *20830	*9450 *20830	*10870 *23960	6940 15300	*7820 *17240	4420 9740	5720 12610	3030 6680	3560 7850	1790 3950	9.95 (32.6)
Ground Line	kg lb			*10570 *23300	*10570 *23300	*12490 *27540	6430 14180	7980 17590	4120 9080	5530 12190	2850 6280	3710 8180	1860 4100	9.65 (31.7)
-1.5 m (-5 ft)	kg lb	*9940 *21910	*9940 *21910	*13870 *30580	12620 27820	12870 28370	6250 13780	7790 17170	3960 8730	5430 11970	2760 6080	4130 9110	2100 4630	9.05 (29.7)
-3.0 m (-10 ft)	kg lb	*13540 *29850	*13540 *29850	*18430 *40630	12840 28310	*12780 *28180	6270 13820	7780 17150	3950 8710			5060 11160	2640 5820	8.06 (26.4)
-4.5 m (-15 ft)	kg lb	*17830 *39310	*17830 *39310	*16580 *36550	13290 29300	*11360 *25040	6490 14310	7980 17590	4120 9080			*5940 *13100	4010 8840	6.48 (21.3)

(4) 5.85 m (19' 2") boom, 3.60 m (11' 10") arm equipped with 1.08 m³ (SAE heaped) bucket and 600 mm (24") triple grouser shoe and 4600 kg (10140 lb) counterweight.











Load point height		Load radius												At max. reach		
		1.5 m (5 ft)		3.0 m (10 ft)		4.5 m (15 ft)		6.0 m (20 ft)		7.5 m (25 ft)		9.0 m (30 ft)		Capacity		Reach
																
6.0 m (20 ft)	kg lb									*3930 *8660	3660 8070			3940 8690	2090 4610	9.77 (32.1)
4.5 m (15 ft)	kg lb									*4530 *9990	3510 7740	*2500 *5510	2350 5180	3510 7740	1790 3950	10.27 (33.7)
3.0 m (10 ft)	kg lb							*5890 *12990	4940 10890	*5190 *11440	3290 7250	*3590 *7910	2250 4960	3290 7250	1630 3590	10.49 (34.4)
1.5 m (5 ft)	kg lb			*12610 *27800	*12610 *27800	*9960 *21960	7160 15790	*7260 *16010	4510 9940	5760 12700	3060 6750	4180 9220	2130 4700	3240 7140	1580 3480	10.46 (34.3)
Ground Line	kg lb			*11020 *24290	*11020 *24290	*11930 *26300	6540 14420	8030 17700	4160 9170	5540 12210	2860 6310	4070 8970	2030 4480	3360 7410	1640 3620	10.18 (33.4)
-1.5 m (-5 ft)	kg lb	*9010 *19860	*9010 *19860	*13200 *29100	12560 27690	12890 28420	6250 13780	7790 17170	3950 8710	5400 11900	2730 6020			3690 8140	1830 4030	9.62 (31.6)
-3.0 m (-10 ft)	kg lb	*12120 *26720	*12120 *26720	*16820 *37080	12660 27910	12820 28260	6190 13650	7710 17000	3880 8550	5370 11840	2700 5950			4390 9680	2240 4940	8.71 (28.6)
-4.5 m (-15 ft)	kg lb	*15830 *34900	*15830 *34900	*17940 *39550	13010 28680	*12020 *26500	6330 13960	7820 17240	3970 8750					*5790 *12760	3190 7030	7.30 (24.0)

3) R250LC-9 HIGH WALKER

(1) 5.85 m (19' 2") boom, 2.10 m (6' 11") arm equipped with 1.08 m³ (SAE heaped) bucket, 600 mm (24") triple grouser shoe and 4600 kg (10140 lb) counterweight.













·  : Rating over-front

·  : Rating over-side or 360 degree













Load point height		Load radius								At max. reach		
		3.0 m (10 ft)		4.5 m (15 ft)		6.0 m (20 ft)		7.5 m (25 ft)		Capacity		Reach
												m (ft)
6.0 m (20 ft)	kg lb					*5910 *13030	*5910 *13030			*5290 *11660	3780 8330	8.49 (27.9)
4.5 m (15 ft)	kg lb			*8350 *18410	*8350 *18410	*6750 *14880	6680 14730	*6080 *13400	4530 9990	5310 11710	3310 7300	9.00 (29.5)
-3.0 m (-10 ft)	kg lb			*10830 *23880	9880 21780	*7870 *17350	6290 13870	*6580 *14510	4370 9630	5040 11110	3110 6860	9.19 (30.2)
-1.5 m (-5 ft)	kg lb			*12610 *27800	9280 20460	*8890 *19600	5970 13160	6840 15080	4210 9280	5080 11200	3120 6860	9.09 (30.2)
Ground Line	kg lb			*13240 *29190	9080 20020	*9480 *20900	5790 12760	6740 14860	4120 9080	5450 12020	3360 7410	8.68 (28.5)
-1.5 m (-5 ft)	kg lb	*17510 *38600	*17510 *38600	*12940 *28530	9100 20060	*9460 *20860	5760 12700			*6350 *14000	3950 8710	7.91 (26.0)
-3.0 m (-10 ft)	kg lb	*16440 *36240	*16440 *36240	*11670 *25730	9310 20530	*8440 *18610	5920 13050			*6190 *13650	5420 11950	6.61 (21.7)

- Note
1. Lifting capacity are based on SAE J1097 and ISO 10567.
 2. Lifting capacity of the ROBEX series does not exceed 75% of tipping load with the machine on firm, level ground or 87% of full hydraulic capacity.
 3. The load point is a hook located on the back of the bucket.
 4. *indicates load limited by hydraulic capacity.















(2) 5.85 m (19' 2") boom, 2.50 m (8' 2") arm equipped with 1.08 m³ (SAE heaped) bucket and 600 mm (24") triple grouser shoe and 4600 kg (10140 lb) counterweight.

Load point height		Load radius										At max. reach		
		1.5 m (5 ft)		3.0 m (10 ft)		4.5 m (15 ft)		6.0 m (20ft)		7.5 m (25ft)		Capacity		Reach
														m (ft)
6.0 m (20 ft)	kg lb							*5440 *11990	*5440 *11990			*4950 *10910	3560 7850	8.83 (29.0)
4.5 m (15 ft)	kg lb					*7630 *16820	*7630 *16820	*6320 *13930	*6320 *13930	*5730 *12630	4600 10140	5030 11090	3140 6920	9.32 (30.6)
3.0 m (10 ft)	kg lb					*10140 *22350	10080 22220	*7500 *16530	6380 14070	*6300 *13890	4410 9720	4790 10560	2950 6500	9.50 (31.2)
1.5 m (5 ft)	kg lb					*12180 *26850	9390 20700	*8620 *19000	6020 13270	6860 15120	4230 9330	4810 10600	2940 6480	9.40 (30.8)
Ground Line	kg lb					*13120 *28920	9090 20040	*9350 *20610	5800 12790	6730 14840	4110 9060	5120 11290	3140 6920	9.01 (29.6)
-1.5 m (-5 ft)	kg lb	*12120 *26720	*12120 *26720	*16630 *36660	*16630 *36660	*13100 *28880	9050 19950	*9510 *20970	5730 12630			5900 13010	3640 8020	8.28 (27.2)
-3.0 m (-10 ft)	kg lb	*17840 *39330	*17840 *39330	*17530 *38650	*17530 *38650	*12140 *26760	9210 20300	*8850 *19510	5830 12850			*6280 *13850	4810 10600	7.07 (23.2)
-4.5 m (-15 ft)	kg lb			*13700 *30200	*13700 *30200	*9570 *21100	*9570 *21100							

(3) 5.85 m (19' 2") boom, 3.05 m (10' 0") arm equipped with 1.08 m³ (SAE heaped) bucket and 600 mm (24") triple grouser shoe and 4600 kg (10140 lb) counterweight.

Load point height		Load radius										At max. reach		
		1.5 m (5 ft)		3.0 m (10 ft)		4.5 m (15 ft)		6.0 m (20ft)		7.5 m (25ft)		Capacity		Reach
														m (ft)
6.0 m (20 ft)	kg lb									*4140 *9130	*4140 *9130	*4510 *9940	3190 7030	9.37 (30.7)
4.5 m (15 ft)	kg lb							*5610 *12370	*5610 *12370	*5180 *11420	4650 10250	4590 10120	2830 6240	9.82 (32.2)
3.0 m (10 ft)	kg lb			*15320 *33770	*15320 *33770	*9030 *19910	*9030 *19910	*6850 *15100	6450 14220	*5830 *12850	4430 9770	4370 9630	2660 5860	9.99 (32.8)
1.5 m (5 ft)	kg lb			*9310 *20530	*9310 *20530	*11350 *25020	9510 20970	*8090 *17840	6050 13340	*6510 *14350	4220 9300	4380 9660	2650 5840	9.90 (32.5)
Ground Line	kg lb	*7350 *16200	*7350 *16200	*11240 *24780	*11240 *24780	*12710 *28020	9060 19970	*9010 *19860	5760 12700	6680 14730	4060 8950	4620 10190	2800 6170	9.53 (31.3)
-1.5 m (-5 ft)	kg lb	*10760 *23720	*10760 *23720	*14820 *32670	*14820 *32670	*13100 *28880	8920 19670	*9410 *20750	5640 12430	6610 14570	3990 8800	5220 11510	3180 7010	8.85 (29.0)
-3.0 m (-10 ft)	kg lb	*14470 *31900	*14470 *31900	*18710 *41250	*18710 *41250	*12560 *27690	9000 19840	*9310 *20130	5660 12480			*6000 *13230	4040 8910	7.76 (25.5)
-4.5 m (-15 ft)	kg lb			*15670 *34550	*15670 *34550	*10780 *23770	9290 20480							

(4) 5.85 m (19' 2") boom, 3.60 m (11' 10") arm equipped with 1.08 m³ (SAE heaped) bucket and 600 mm (24") triple grouser shoe and 4600 kg (10140 lb) counterweight.

Load point height		Load radius												At max. reach		
		1.5 m (5 ft)		3.0 m (10 ft)		4.5 m (15 ft)		6.0 m (20 ft)		7.5 m (25 ft)		9.0 m (30 ft)		Capacity		Reach
																
6.0 m (20 ft)	kg lb									*4150 *9150	*4150 *9150			*4210 *9080	2870 6330	9.92 (32.5)
4.5 m (15 ft)	kg lb									*4670 *10300	*4670 *10300	*2810 *6190	*2810 *6190	4190 9240	2560 5640	10.34 (33.9)
3.0 m (10 ft)	kg lb			*12560 *27690	*12560 *27690	*7950 *17530	*7950 *17530	*6220 *13710	*6220 *13710	*5370 *11840	4480 9880	*3790 *8360	3200 7050	4000 8820	2410 5310	10.50 (34.4)
1.5 m (5 ft)	kg lb			*11430 *25200	*11430 *25200	*10510 *23170	9730 21450	*7570 *16690	6130 13510	*6140 *13540	4240 9350	*4350 *9590	3070 6770	4000 8820	2390 5270	10.42 (34.2)
Ground Line	kg lb	*6810 *15010	*6810 *15010	*11370 *25070	*11370 *25070	*12250 *27010	9150 20170	*8650 *19070	5800 12790	6680 14730	4050 8930	*4060 *8950	2980 6570	4200 9260	2510 5530	10.07 (33.0)
-1.5 m (-5 ft)	kg lb	*9710 *21410	*9710 *21410	*13930 *30710	*13930 *30710	*13000 *28660	8910 19640	*9270 *20440	5610 12370	6560 14460	3940 8690			4670 10300	2810 6190	9.44 (31.0)
-3.0 m (-10 ft)	kg lb	*12930 *28510	*12930 *28510	*17900 *39460	*17900 *39460	*12840 *28310	8900 19620	*9280 *20460	5580 12300	6560 14460	3940 8690			5650 12460	3450 7610	8.43 (27.7)
-4.5 m (-15 ft)	kg lb	*16850 *37150	*16850 *37150	*17220 *37960	*17220 *37960	*11600 *25570	9100 20060	*8340 *18390	5720 12610					*5770 *12720	5000 11020	6.86 (22.5)

6. BUCKET SELECTION GUIDE

1) GENERAL BUCKET

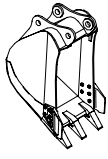
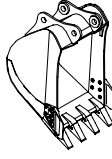
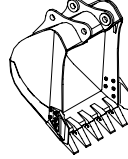
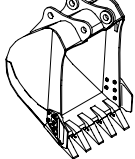
			
0.60 m ³ SAE 0.79 m ³ SAE heaped bucket	1.03 m ³ SAE heaped bucket	※ 1.08 m ³ SAE heaped bucket	1.27 m ³ SAE 1.50 m ³ SAE heaped bucket

Capacity		Width		Weight	Recommendation			
					5.85m (19' 2") boom			
SAE heaped	CECE heaped	Without side cutter	With side cutter		2.1m arm (6' 11")	2.5m arm (8' 2")	3.05m arm (10' 0")	3.6m arm (11' 10")
0.60 m ³ (0.78 yd ³)	0.55 m ³ (0.72 yd ³)	760 mm (29.9")	880 mm (34.6")	720 kg (1590 lb)				
0.79 m ³ (1.03 yd ³)	0.70 m ³ (0.92 yd ³)	890 mm (35.0")	1010 mm (39.8")	790 kg (1740 lb)				
1.03 m ³ (1.35 yd ³)	0.90 m ³ (1.18 yd ³)	1090 mm (42.9")	1210 mm (47.6")	890 kg (1960 lb)				
※ 1.08 m ³ (1.41 yd ³)	0.95 m ³ (1.24 yd ³)	1130 mm (44.5")	1250 mm (49.2")	910 kg (2010 lb)				
1.27 m ³ (1.66 yd ³)	1.10 m ³ (1.44 yd ³)	1290 mm (50.8")	1410 mm (55.5")	1010 kg (2230 lb)				
1.50 m ³ (1.96 yd ³)	1.30 m ³ (1.70 yd ³)	1490 mm (58.7")	1610 mm (63.4")	1080 kg (2380 lb)				

※ : Standard bucket

 Applicable for materials with density of 2000 kgf/m³ (3370 lbf/yd³) or less

 Applicable for materials with density of 1600 kgf/m³ (2700 lbf/yd³) or less

 Applicable for materials with density of 1100 kgf/m³ (1850 lbf/yd³) or less

2) ROCK AND HEAVY DUTY BUCKET

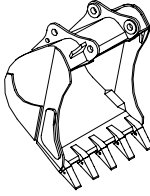
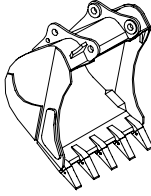
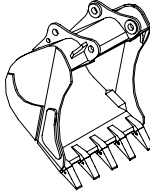
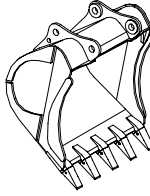
			
<p>◆ 1.07m³ SAE ◆ 1.15m³ SAE heaped bucket</p>	<p>◆ 1.27m³ SAE heaped bucket</p>	<p>◆ 1.46m³ SAE heaped bucket</p>	<p>◎ 1.16m³ SAE heaped bucket</p>

Capacity		Width		Weight	Recommendation			
					5.85 m (19' 2") boom			
SAE heaped	CECE heaped	Without side cutter	With side cutter		2.1 m arm (6' 11")	2.5 m arm (8' 2")	3.05 m arm (10' 0")	3.6 m arm (11' 10")
◆ 1.07 m ³ (1.40 yd ³)	0.95 m ³ (1.24 yd ³)	1150 mm (45.3")	-	1120 kg (2470 lb)				
◆ 1.15 m ³ (1.50 yd ³)	1.00 m ³ (1.31 yd ³)	1210 mm (47.6")	-	1160 kg (2560 lb)				
◆ 1.27 m ³ (1.66 yd ³)	1.10 m ³ (1.44 yd ³)	1310 mm (51.6")	-	1240 kg (2730 lb)				
◆ 1.46 m ³ (1.91 yd ³)	1.28 m ³ (1.67 yd ³)	1460 mm (57.5")	-	1320 kg (2910 lb)				
◎ 1.16 m ³ (1.52 yd ³)	1.00 m ³ (1.31 yd ³)	1340 mm (52.8")	-	1280 kg (2820 lb)				

◆ : Heavy duty bucket ◎ : Rock-Heavy duty bucket

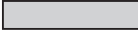
 Applicable for materials with density of 2000 kgf/m³ (3370 lbf/yd³) or less

 Applicable for materials with density of 1600 kgf/m³ (2700 lbf/yd³) or less

 Applicable for materials with density of 1100 kgf/m³ (1850 lbf/yd³) or less

7. UNDERCARRIAGE

1) TRACKS

X-leg type center frame is integrally welded with reinforced box-section track frames. The design includes dry tracks, lubricated rollers, idlers, sprockets, hydraulic track adjusters with shock absorbing springs and assembled track-type tractor shoes with triple grousers.

2) TYPES OF SHOES

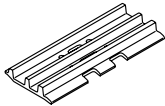
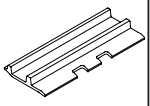
Model	Shapes		Triple grouser				Double grouser
							
R250LC-9	Shoe width	mm (in)	600 (24)	700 (28)	800 (32)	900 (36)	-
	Operating weight	kg (lb)	25200 (55600)	25500 (26200)	25800 (56900)	26100 (57500)	-
	Ground pressure	kgf/cm ² (psi)	0.51 (7.25)	0.44 (6.26)	0.39 (5.55)	0.35 (4.98)	-
	Overall width	mm (ft-in)	3180 (10' 5")	3280 (10' 9")	3380 (11' 1")	3480 (11' 5")	-
R250NLC-9	Shoe width	mm (in)	600 (24)	-	-	-	-
	Operating weight	kg (lb)	25100 (55300)	-	-	-	-
	Ground pressure	kgf/cm ² (psi)	0.51 (7.25)	-	-	-	-
	Overall width	mm (ft-in)	2980 (9' 9")	-	-	-	-
R250LC-9 HIGH WALKER	Shoe width	mm (in)	600 (24)	700 (28)	800 (32)	-	700 (28)
	Operating weight	kg (lb)	27450 (60520)	28020 (61770)	28400 (62610)	-	28620 (63100)
	Ground pressure	kgf/cm ² (psi)	0.53 (7.54)	0.46 (6.54)	0.41 (5.83)	-	0.47 (6.68)
	Overall width	mm (ft-in)	3180 (10' 5")	3280 (10' 9")	3380 (11' 1")	-	3280 (10' 9")

3) NUMBER OF ROLLERS AND SHOES ON EACH SIDE

Item	Quantity	
	R250LC-9, R250NLC-9	R250LC-9 HIGH WALKER
Carrier rollers	2 EA	2 EA
Track rollers	9 EA	9 EA
Track shoes	51 EA	48 EA

4) SELECTION OF TRACK SHOE

Suitable track shoes should be selected according to operating conditions.

Method of selecting shoes

Confirm the category from the list of applications in table 2, then use table 1 to select the shoe. Wide shoes (Categories B and C) have limitations on applications. Before using wide shoes, check the precautions, then investigate and study the operating conditions to confirm if these shoes are suitable.

Select the narrowest shoe possible to meet the required flotation and ground pressure. Application of wider shoes than recommendations will cause unexpected problems such as bending of shoes, crack of link, breakage of pin, loosening of shoe bolts and the other various problems.

※ **Table 1**

Track shoe	Specification	Category
600mm triple grouser	Standard	A
700mm triple grouser	Option	B
700mm double grouser ★1	Option	B
800mm triple grouser	Option	C
900mm triple grouser	Option	C

★1 : R250LC-9 HIGH WALKER ONLY

※ **Table 2**

Category	Applications	Precautions
A	Rocky ground, river beds, normal soil	<ul style="list-style-type: none"> Travel at low speed on rough ground with large obstacles such as boulders or fallen trees
B	Normal soil, soft ground	<ul style="list-style-type: none"> These shoes cannot be used on rough ground with large obstacles such as boulders or fallen trees Travel at high speed only on flat ground Travel slowly at low speed if it is impossible to avoid going over obstacles
C	Extremely, soft ground (Swampy ground)	<ul style="list-style-type: none"> Use the shoes only in the conditions that the machine sinks and it is impossible to use the shoes of category A or B These shoes cannot be used on rough ground with large obstacles such as boulders or fallen trees Travel at high speed only on flat ground Travel slowly at low speed if it is impossible to avoid going over obstacles

8. SPECIFICATIONS FOR MAJOR COMPONENTS

1) ENGINE

Item	Specification
Model	Cummins QSB6.7 / HYUNDAI HE 6.7
Type	4-cycle turbocharged, charger air cooled diesel engine
Cooling method	Water cooling
Number of cylinders and arrangement	6 cylinders, in-line
Firing order	1-5-3-6-2-4
Combustion chamber type	Direct injection type
Cylinder bore × stroke	107 × 124 mm (4.2" × 4.9")
Piston displacement	6700 cc (409 cu in)
Compression ratio	17.2 : 1
Rated gross horse power (SAE J1995)	195 Hp at 1900 rpm (146 kW at 1900 rpm)
Maximum torque	95.0 kgf · m (687 lbf · ft) at 1400 rpm
Engine oil quantity	24 l (6.3 U.S. gal)
Dry weight	556 kg (1225 lb)
High idling speed	1950+ 50 rpm
Low idling speed	850 ± 100 rpm
Rated fuel consumption	167.4 g/Hp · hr at 1900 rpm
Starting motor	Nippon denso (24V-4.5 kW)
Alternator	Delco Remy 24V-50A
Battery	2 × 12V × 100 Ah

2) MAIN PUMP

Item	Specification
Type	Variable displacement tandem axis piston pumps
Capacity	2 × 117 cc/rev
Maximum pressure	350 kgf/cm ² (4980 psi) [380 kgf/cm ² (5400 psi)]
Rated oil flow	2 × 222 l /min (58.7 U.S. gpm/ 48.8 U.K. gpm)
Rated speed	1900 rpm

[] : Power boost

3) GEAR PUMP

Item	Specification
Type	Fixed displacement gear pump single stage
Capacity	15 cc/rev
Maximum pressure	40 kgf/cm ² (570 psi)
Rated oil flow	28.5 l /min (7.45 U.S. gpm / 6.27 U.K. gpm)
Rated speed	1900 rpm

4) MAIN CONTROL VALVE

Item	Specification
Type	9 spools
Operating method	Hydraulic pilot system
Main relief valve pressure	350 kgf/cm ² (4980 psi) [380 kgf/cm ² (5400 psi)]
Overload relief valve pressure	400 kgf/cm ² (5690 psi)

[] : Power boost

5) SWING MOTOR

Item	Specification
Type	Axial piston motor
Capacity	148.5 cc/rev
Relief pressure	300 kgf/cm ² (4270 psi)
Braking system	Automatic, spring applied hydraulic released
Braking torque	70 kgf · m (506 lbf · ft)
Brake release pressure	35 kgf/cm ² (500 psi)
Reduction gear type	2 - stage planetary

6) TRAVEL MOTOR

Item	Specification
Type	Axial piston motor
Relief pressure	350 kgf/cm ² (4980 psi)
Capacity (max / min)	161.5/93.5 cc/rev
Reduction gear type	Planetary differential
Braking system	Automatic, spring applied hydraulic released
Brake release pressure	8.2 kgf/cm ² (116 psi)
Braking torque	50 kgf · m (362 lbf · ft)

7) CYLINDER

Item		Specification
Boom cylinder	Bore dia × Rod dia × Stroke	∅ 135 × ∅ 95 × 1345 mm
	Cushion	Extend only
Arm cylinder	Bore dia × Rod dia × Stroke	∅ 145 × ∅ 105 × 1620 mm
	Cushion	Extend and retract
Bucket cylinder	Bore dia × Rod dia × Stroke	∅ 130 × ∅ 90 × 1185 mm
	Cushion	Extend only

※ Discoloration of cylinder rod can occur when the friction reduction additive of lubrication oil spreads on the rod surface.

※ Discoloration does not cause any harmful effect on the cylinder performance.

8) SHOE

Item		Width	Ground pressure	Link quantity	Overall width
R250LC-9	Standard	600 mm (24")	0.51 kgf/cm ² (7.25 psi)	51	3180 mm (10' 5")
	Option	700 mm (28")	0.44 kgf/cm ² (6.26 psi)	51	3280 mm (10' 9")
		800 mm (32")	0.39 kgf/cm ² (5.55 psi)	51	3380 mm (11' 1")
		900 mm (36")	0.35 kgf/cm ² (4.98 psi)	51	3480 mm (11' 5")
R250NLC-9	Standard	600 mm (24")	0.51 kgf/cm ² (7.25 psi)	51	2980 mm (9' 9")
R250LC-9 HIGH WALKER	Standard	600 mm (24")	0.53 kgf/cm ² (7.54 psi)	48	3180 mm (10' 5")
	Option	700 mm (28")	0.46 kgf/cm ² (6.54 psi)	48	3280 mm (10' 9")
		800 mm (32")	0.41 kgf/cm ² (5.83 psi)	48	3380 mm (11' 1")
		★700 mm (28")	0.47 kgf/cm ² (6.68 psi)	48	3280 mm (10' 9")

★: Double grouser

9) BUCKET

Item		Capacity		Tooth quantity	Width	
		SAE heaped	CECE heaped		Without side cutter	With side cutter
R250LC-9 R250NLC-9 R250LC-9 H/WALKER	Standard	1.08 m ³ (1.41 yd ³)	0.95 m ³ (1.24 yd ³)	5	1130 mm (44.5")	1250 mm (49.2")
	Option	0.60 m ³ (0.78 yd ³)	0.55 m ³ (0.72 yd ³)	3	760 mm (29.9")	880 mm (34.6")
		0.79 m ³ (1.03 yd ³)	0.70 m ³ (0.92 yd ³)	3	890 mm (35.0")	1010 mm (39.8")
		1.03 m ³ (1.35 yd ³)	0.90 m ³ (1.18 yd ³)	4	1090 mm (42.9")	1210 mm (47.6")
		1.27 m ³ (1.66 yd ³)	1.10 m ³ (1.44 yd ³)	5	1290 mm (50.8")	1410 mm (55.5")
		◆1.07 m ³ (1.40 yd ³)	0.95 m ³ (1.24 yd ³)	5	1150 mm (45.3")	-
		◆1.15 m ³ (1.50 yd ³)	1.00 m ³ (1.31 yd ³)	5	1210 mm (47.6")	-
		◆1.27 m ³ (1.66 yd ³)	1.10 m ³ (1.44 yd ³)	5	1310 mm (51.6")	-
		◆1.46 m ³ (1.91 yd ³)	1.28 m ³ (1.67 yd ³)	5	1460 mm (57.5")	-
		◎1.16 m ³ (1.52 yd ³)	1.00 m ³ (1.31 yd ³)	5	1340 mm (52.8")	-
		1.50 m ³ (1.96 yd ³)	1.30 m ³ (1.70 yd ³)	6	1490 mm (58.7")	1610 mm (63.4")

◆ : Heavy duty bucket

◎ : Rock bucket

9. RECOMMENDED OILS

Use only oils listed below. Do not mix different brand oil.

Please use HYUNDAI genuine oil and grease.

Service point	Kind of fluid	Capacity ℓ (U.S. gal)	Ambient temperature °C (°F)						
			-50 (-58)	-30 (-22)	-20 (-4)	-10 (14)	0 (32)	10 (50)	20 (68)
Engine oil pan	Engine oil	24 (6.3)	★SAE 5W-40						
			SAE 30						
			SAE 10W						
			SAE 10W-30						
			SAE 15W-40						
Swing drive	Gear oil	6.0 (1.6)							
Final drive		3.3×2 (0.9×2)	★SAE 75W-90						
Final drive (H/W)		8.0×2 (2.1×2)	SAE 80W-90						
Hydraulic tank	Hydraulic oil	Tank; 165 (43.6) System; 285 (75.3)	★ISO VG 15						
			ISO VG 32						
			ISO VG 46						
			ISO VG 68						
Fuel tank	Diesel fuel	400 (106)	★ASTM D975 NO.1						
			ASTM D975 NO.2						
Fitting (grease nipple)	Grease	As required	★NLGI NO.1						
			NLGI NO.2						
Radiator (reservoir tank)	Mixture of antifreeze and water	35 (9.2)	Ethylene glycol base permanent type (50 : 50)						
			★Ethylene glycol base permanent type (60 : 40)						

SAE : Society of Automotive Engineers

API : American Petroleum Institute

ISO : International Organization for Standardization

NLGI : National Lubricating Grease Institute

ASTM : American Society of Testing and Material

★ : Cold region

Russia, CIS, Mongolia