

SECTION 3 HYDRAULIC SYSTEM

Group 1 Hydraulic Circuit	3-1
Group 2 Main Circuit	3-2
Group 3 Pilot Circuit	3-5
Group 4 Single Operation	3-13
Group 5 Combined Operation	3-23

GROUP 1 HYDRAULIC CIRCUIT

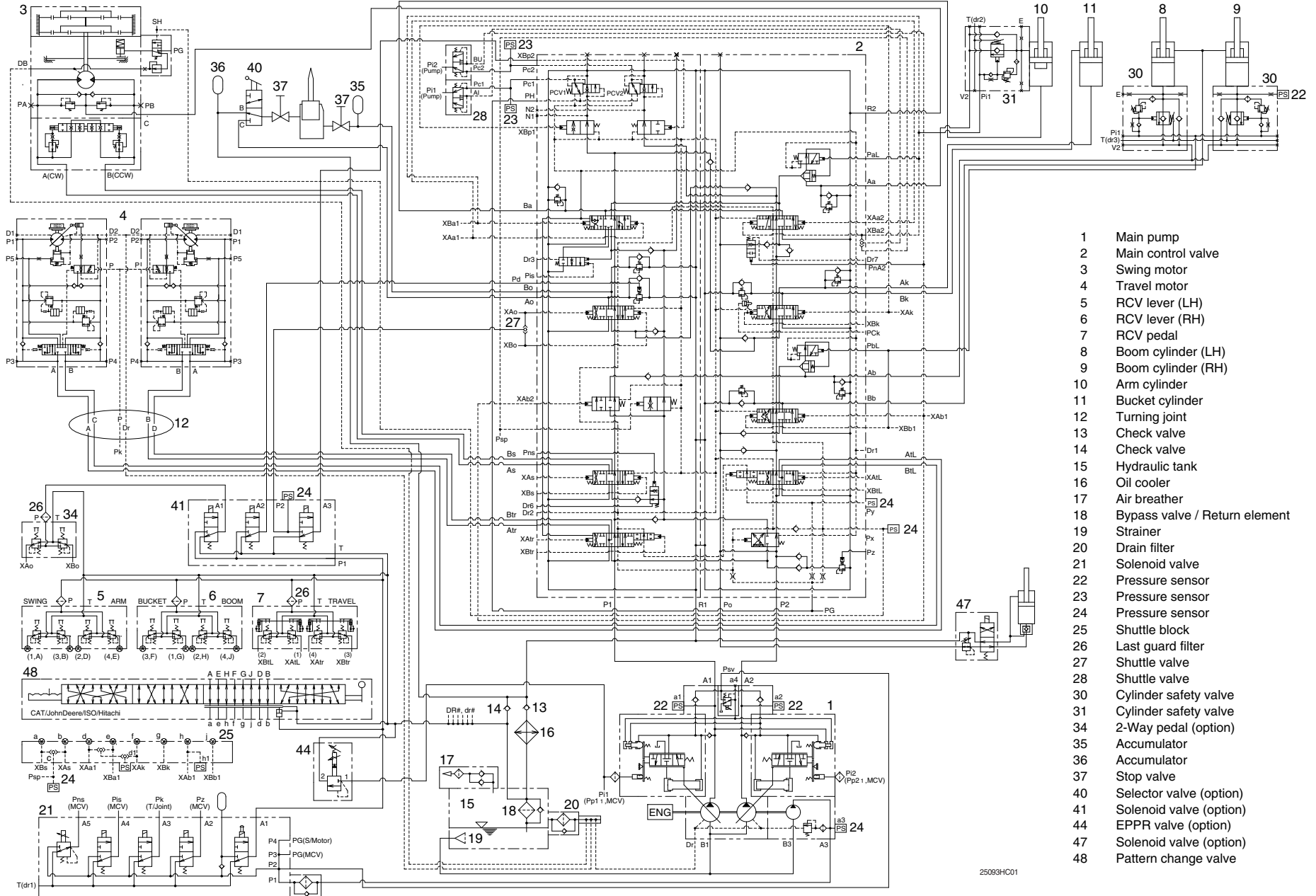

- 1 Main pump
- 2 Main control valve
- 3 Swing motor
- 4 Travel motor
- 5 RCV lever (LH)
- 6 RCV lever (RH)
- 7 RCV pedal
- 8 Boom cylinder (LH)
- 9 Boom cylinder (RH)
- 10 Arm cylinder
- 11 Bucket cylinder
- 12 Turning joint
- 13 Check valve
- 14 Check valve
- 15 Hydraulic tank
- 16 Oil cooler
- 17 Air breather
- 18 Bypass valve / Return element
- 19 Strainer
- 20 Drain filter
- 21 Solenoid valve
- 22 Pressure sensor
- 23 Pressure sensor
- 24 Pressure sensor
- 25 Shuttle block
- 26 Last guard filter
- 27 Shuttle valve
- 28 Shuttle valve
- 29 Cylinder safety valve
- 30 Cylinder safety valve
- 31 Cylinder safety valve
- 32 2-Way pedal (option)
- 33 Accumulator
- 34 Accumulator
- 35 Stop valve
- 36 Selector valve (option)
- 37 Solenoid valve (option)
- 38 EPPR valve (option)
- 39 Solenoid valve (option)
- 40 Pattern change valve