

GROUP 9 SWING SPEED CONTROL SYSTEM

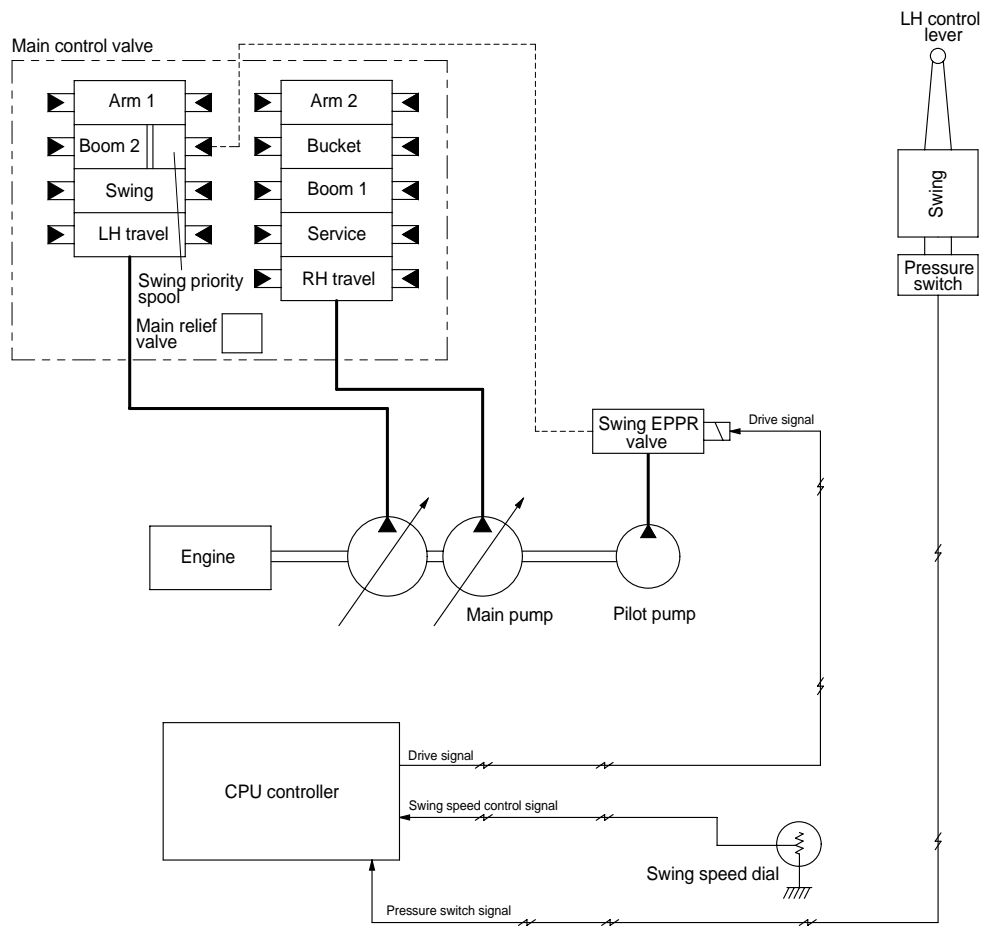

1. SWING SPEED CONTROL SYSTEM

When turning swing speed dial to the left or right, the electric current that flows into the swing EPPR valve is changed and it adjusts pilot oil flowing into the swing priority spool of MCV.

According to the operating rate of swing priority spool, the oil flow of swing section is changed.

Thus, the swing speed is controlled by change of the swing speed dial position.

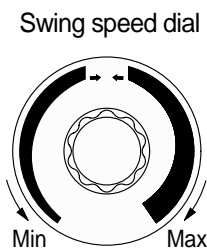

	Swing speed dial	
	Min	Max
Swing EPPR current	0mA	700mA
Swing EPPR valve pressure	0kgf/cm ²	40kgf/cm ²
Swing speed	Slow	Fast