

GROUP 4 SINGLE OPERATION

1. BOOM RAISE OPERATION

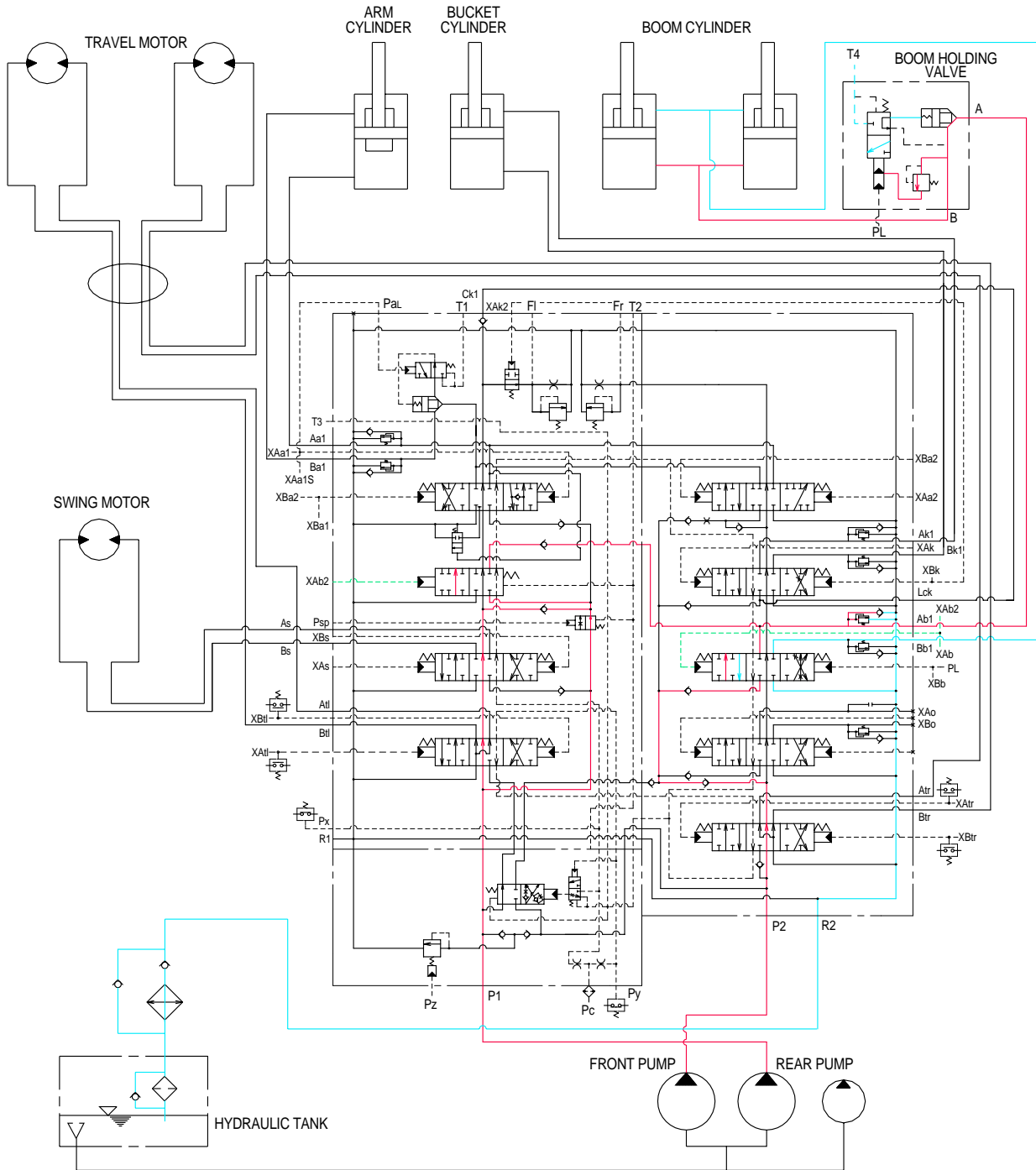

When the right control lever is pulled back, the boom spools in the main control valve are moved to the raise position by the pilot oil pressure from the remote control valve.

The oil from the front and rear pump flows into the main control valve and then goes to the large chamber of boom cylinders.

At the same time, the oil from the small chamber of boom cylinders returns to the hydraulic oil tank through the boom spool in the main control valve. When this happens, the boom goes up.

The excessive pressure in the boom cylinder bottom end circuit is prevented by relief valve.

When the boom is raised and the control lever is returned to neutral position, the circuit for the holding pressure at the bottom end of the boom cylinder is closed by the boom holding valve.

This prevents the hydraulic drift of boom cylinder.

2. BOOM DOWN OPERATION

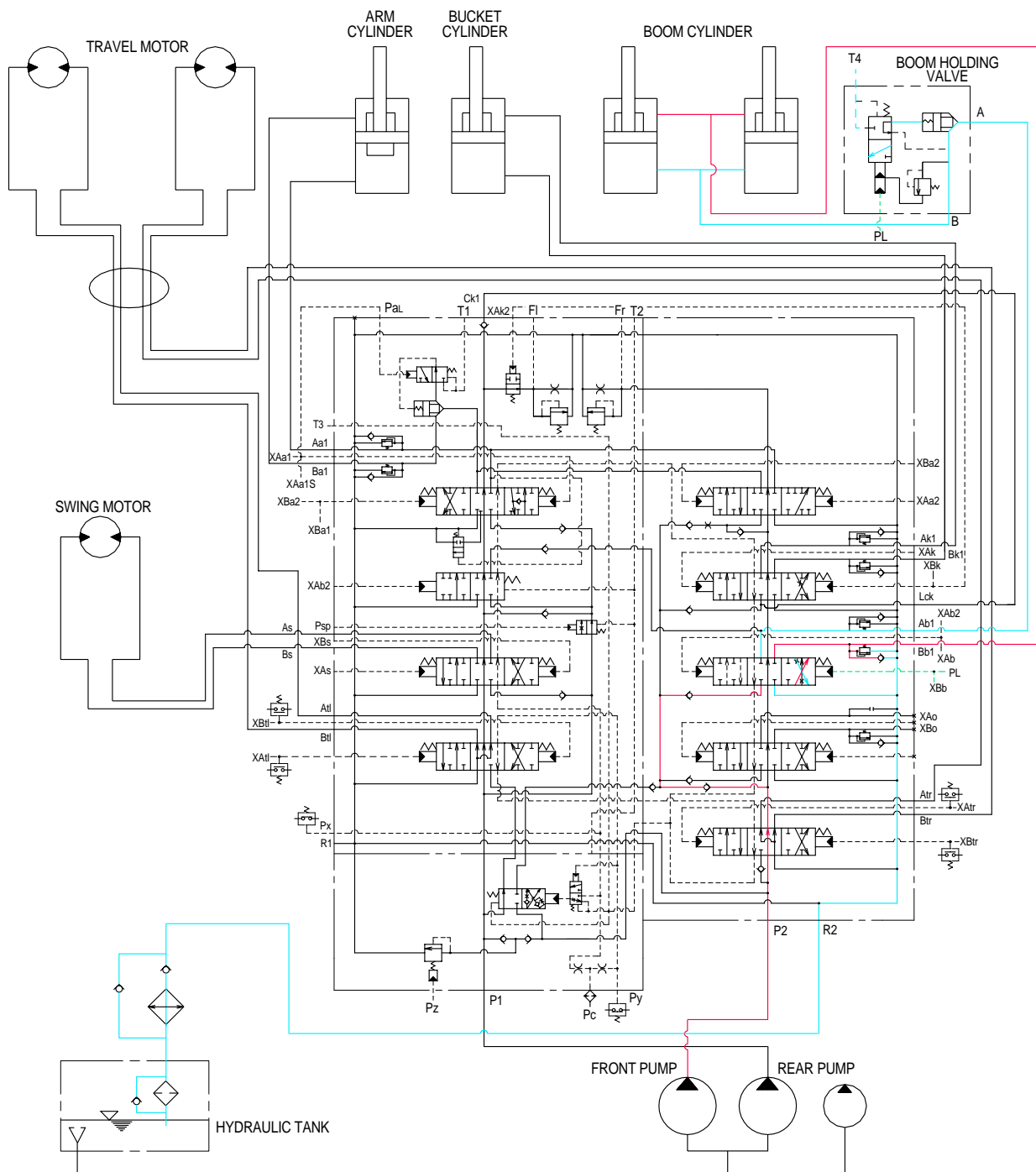

When the right control lever is pushed forward, the boom spools in the main control valve are moved to the lower position by the pilot oil pressure from the remote control valve.

The oil from the front pump flows into the main control valve and then goes to the small chamber of boom cylinders. At the same time, the oil from the large chamber of boom cylinders returns to the hydraulic tank through the boom spool in the main control valve.

When the lowering speed of boom is faster, the oil returned from the large chamber of boom cylinder combines with the oil from the front pump, and flows into the small chamber of the cylinder.

This prevents cylinder cavitation by the negative pressure when the front pump flow can not match the boom down speed. And the excessive pressure in the boom cylinder rod end circuit is prevented by the relief valve.

3. ARM ROLL IN OPERATION

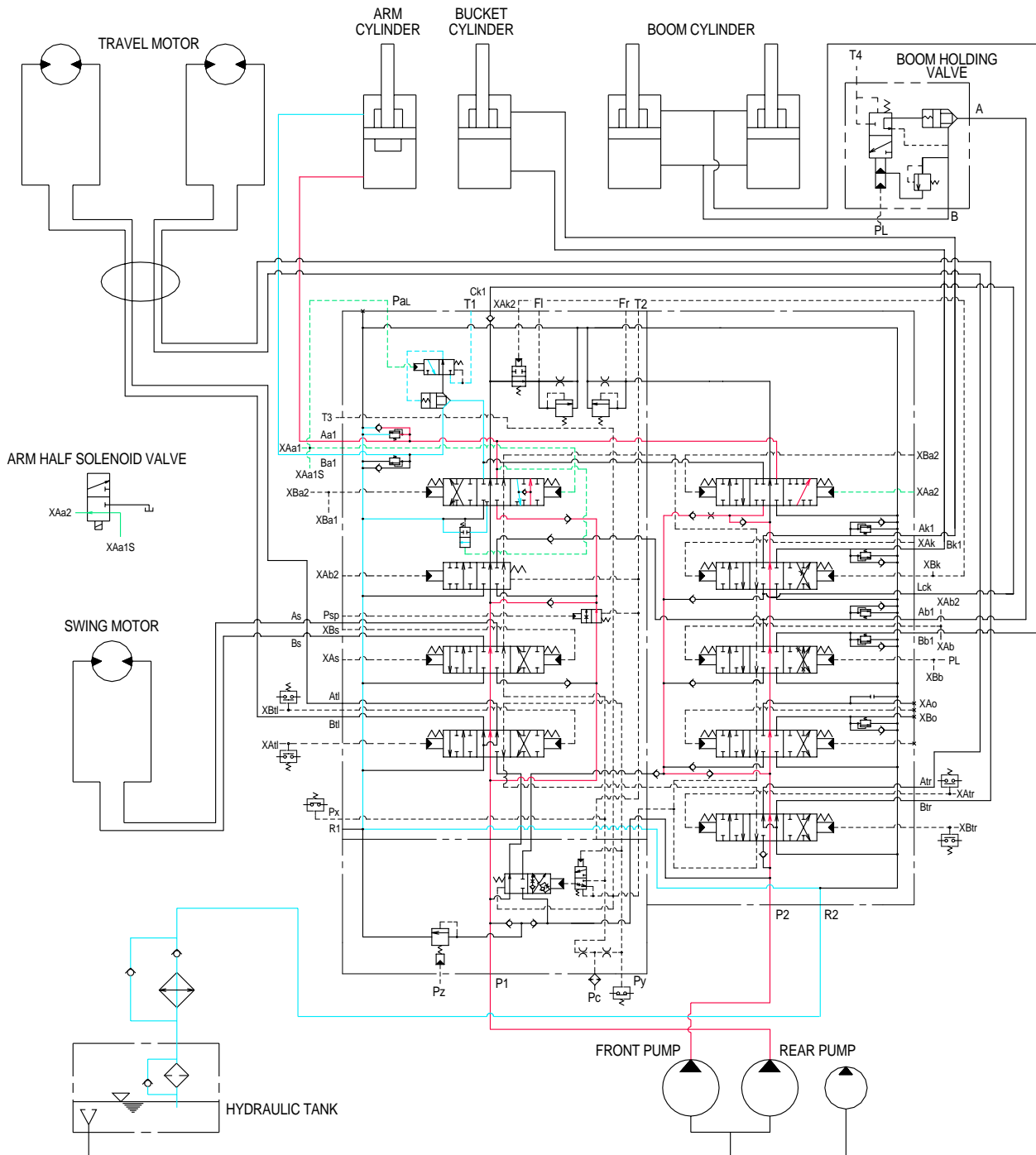

When the left control lever is pulled back the arm spools in the main control valve are moved to the roll in position by the pilot oil pressure from the remote control valve. The oil from the front and rear pump flows into the main control valve and then goes to the large chamber of arm cylinder. At the same time, the oil from small chamber of arm cylinder returns to the hydraulic oil tank through the arm spool in the main control valve. When this happens, the arm rolls in. The cavitation which will happen to the bottom of the arm cylinder is also prevented by the make-up valve in the main control valve.

4. ARM ROLL OUT OPERATION

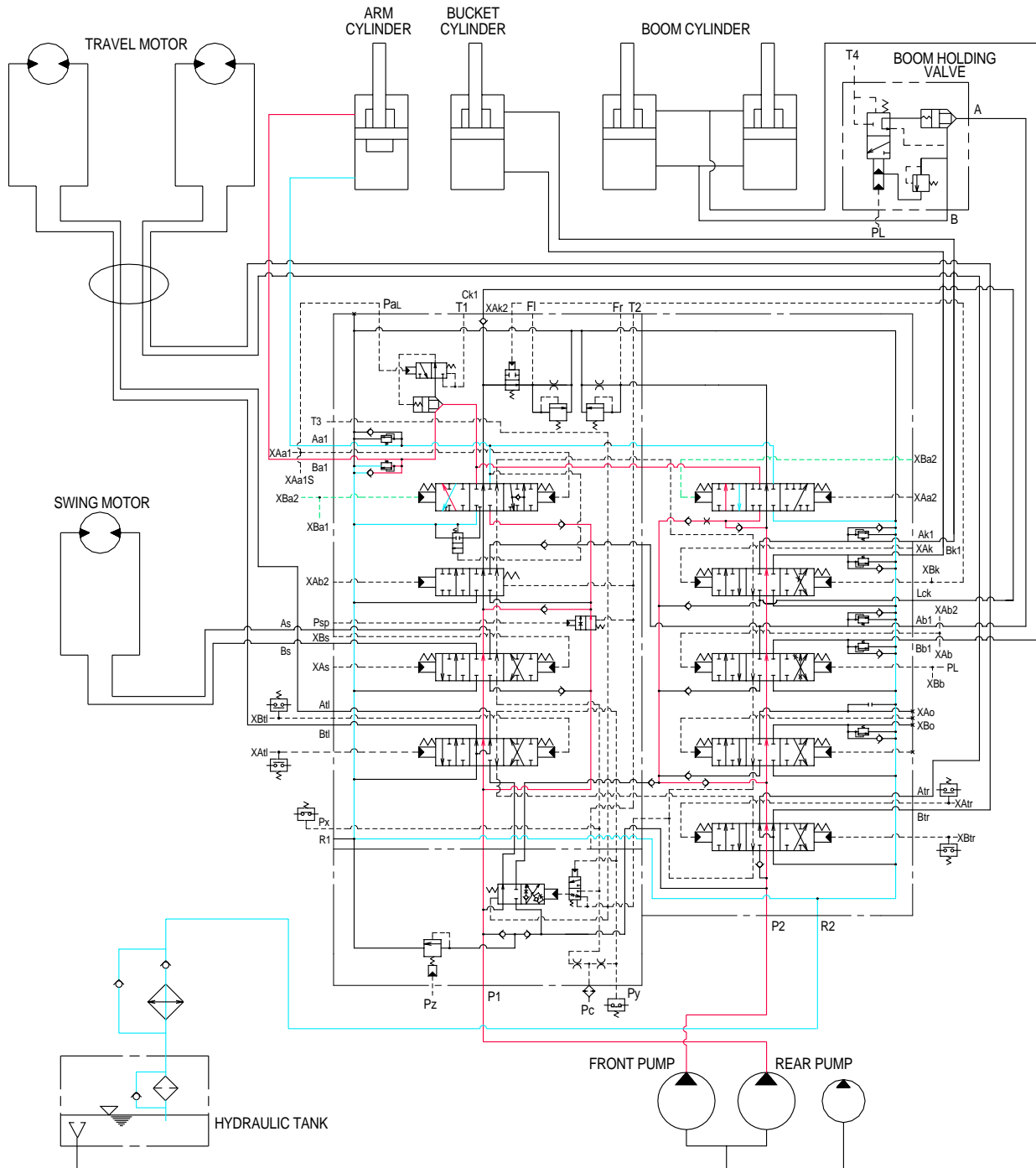

When the left control lever is pushed forward, the arm spool in the main control valve are moved to the roll out position by the pilot oil pressure from the remote control valve.

The oil from the front & rear pump flows into the main control valve and then goes to the small chamber of arm cylinder.

At the same time, the oil from the large chamber of arm cylinder returns to the hydraulic oil tank through the arm spool in the main control valve. When this happens, the arm rolls out.

The cavitation which will happen to the rod of the arm cylinder is also prevented by the make-up valve in the main control valve.

5. BUCKET ROLL IN OPERATION

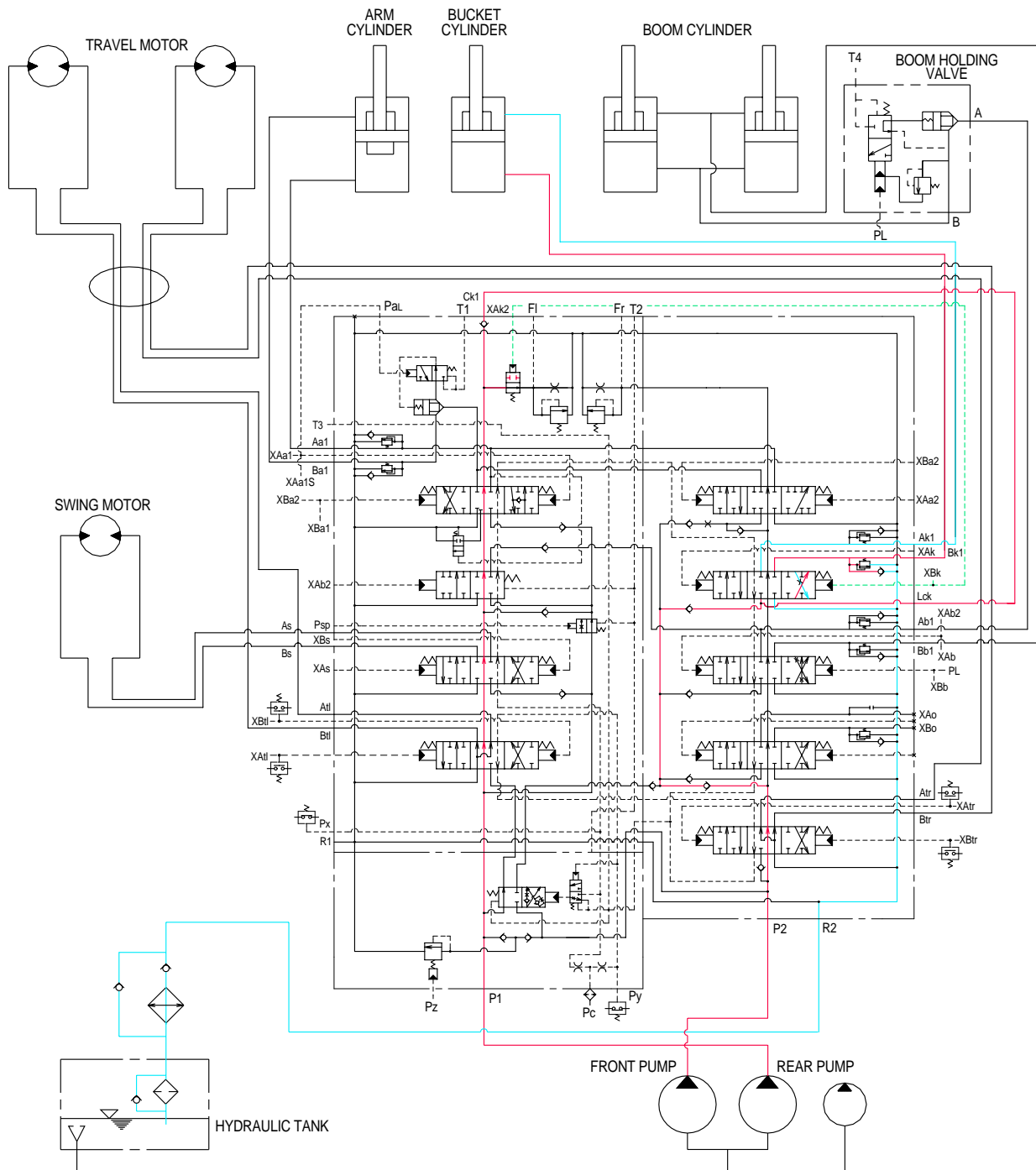

When the right control lever is pulled left, the bucket spool in the main control valve is moved to the roll in position by the pilot oil pressure from the remote control valve.

Also the bucket roll in summation valve is blocked by the pilot oil pressure ; Then the oil from the rear pump join to the front pump flow.

The oil from the front pump and rear pump flows into the main control valve and then goes to the large chamber of bucket cylinder.

At the same time, the oil from the small chamber of bucket cylinder returns to the hydraulic oil tank through the boom spool in the main control valve. When this happens, the bucket rolls in.

The cavitation which will happen to the bottom of the bucket cylinder is also prevented by the make-up valve in the main control valve.

6. BUCKET ROLL OUT OPERATION

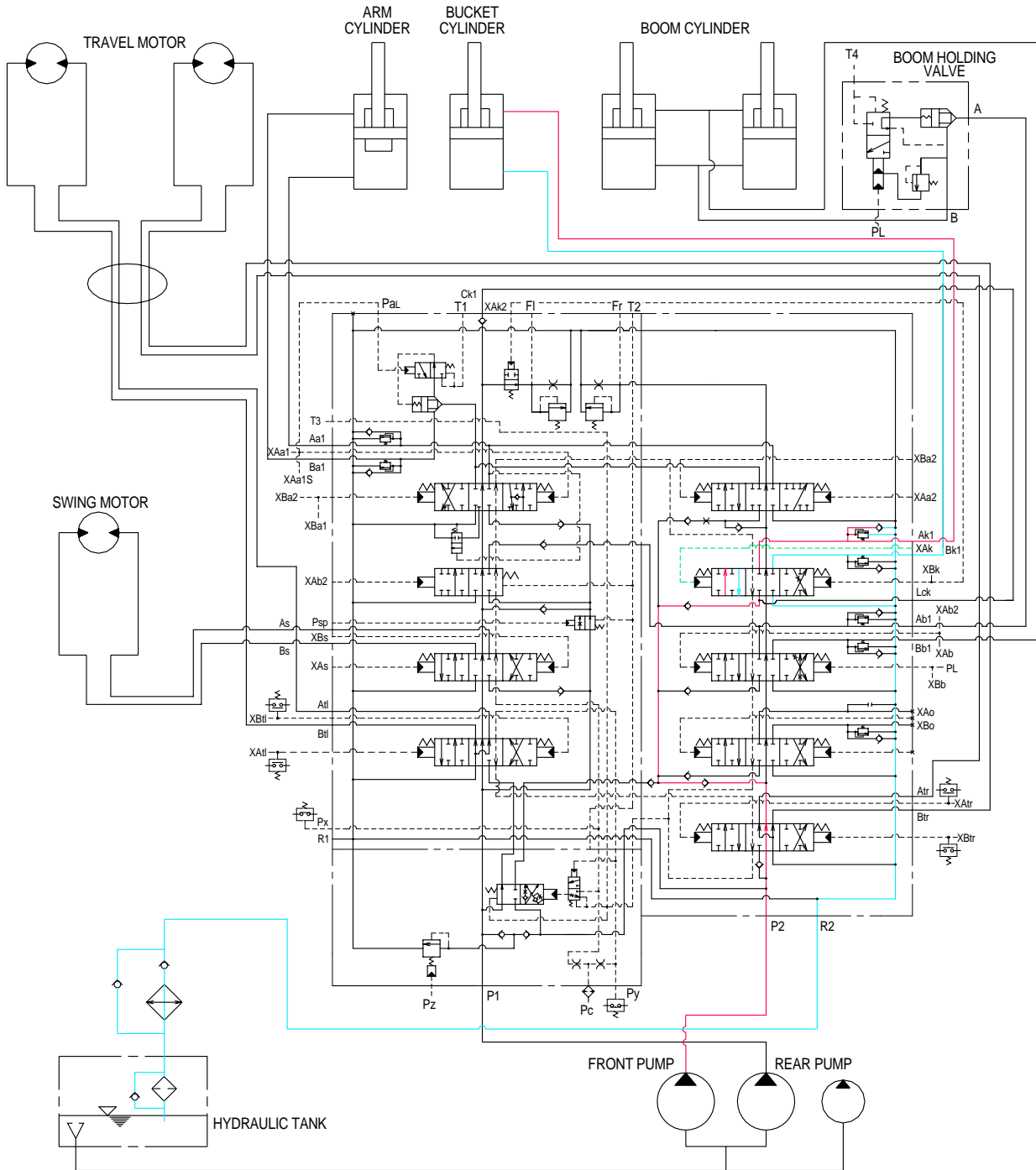

When the right control lever is pushed right, the bucket spool in the main control valve is moved to the roll out position by the pilot oil pressure from the remote control valve.

The oil from the front pump flows into the main control valve and then goes to the small chamber of bucket cylinder.

At the same time, the oil from the large chamber of bucket cylinder returns to the hydraulic oil tank through the bucket spool in the main control valve. When this happens, the bucket rolls out.

The cavitation which will happen to the rod of the bucket cylinder is also prevented by the make-up valve in the main control valve.

7. SWING OPERATION

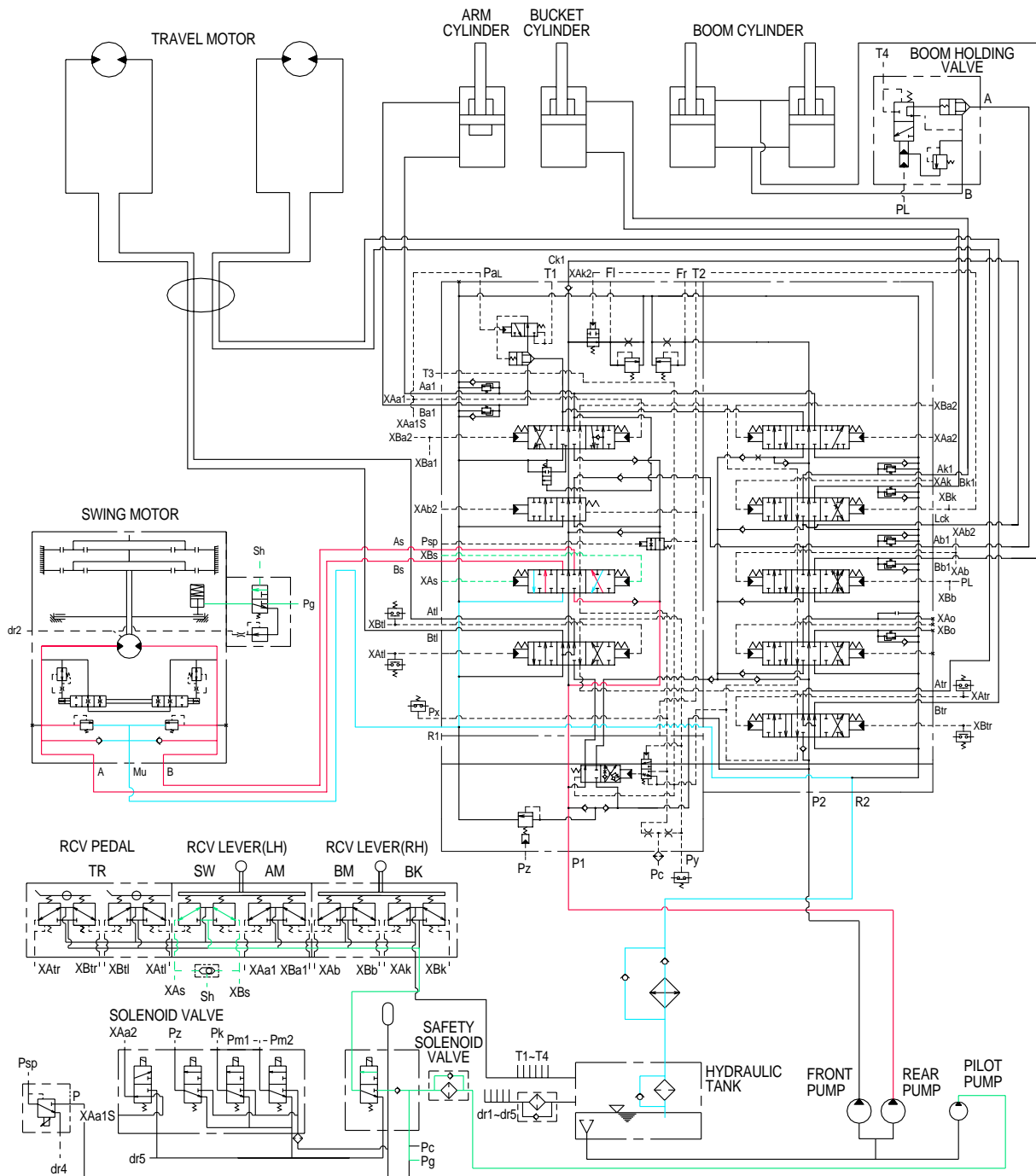

When the left control lever is pushed left or right, the swing spool in the main control valve is moved to the left or right swing position by the pilot oil pressure from the remote control valve.

The oil from the rear pump flows into the main control valve and then goes to the swing motor.

At the same time, the oil returned from the swing motor returns to the hydraulic oil tank through the swing spool in the main control valve.

When this happens, the superstructure swags to the left or right.

The swing parking brake, make up valve and the overload relief valve are provided in the swing motors. The cavitation which will happen to the swing motor is also prevented by the make up valve in the swing motor itself.

SWING CIRCUIT OPERATION

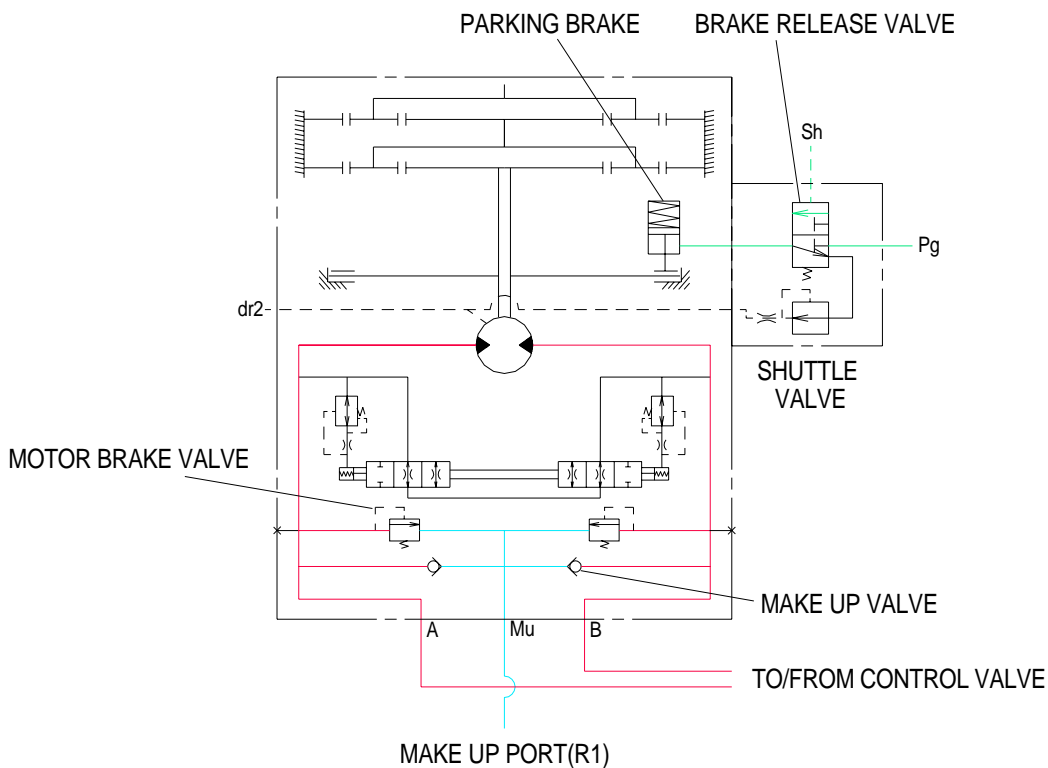

1) MOTOR BREKE VALVE

Motor brake valve for the swing motor limits to cushion the starting and stopping pressure of swing operation.

2) MAKE UP VALVE

The make up valves prevent cavitation by supplying return oil to the vacuum side of the motor.

3) PARKING BRAKE

In case that the parking of the machine at slope is required during operation, there is the danger of involuntary swing caused by the self weight of the machine. The brake is connected to prevent this involuntary swing.

PARKING BRAKE "OFF" OPERATION

The parking brake is released by the pilot pressure oil from the pilot pump.

When the left control lever placed in the swing position, the pilot oil pressure of the shuttle valve is transferred to the brake release valve and the brake release valve is change over. Then the pilot oil pressure lift the brake piston and release the parking brake.

PARKING BRAKE "ON" OPERATION

When the control lever placed in the neutral position, the pressure of the pilot oil passage down.

Then the brake release valve returned to the neutral position and the oil is returned from the brake piston to the tank. And the brake is set to 'ON'.

8. TRAVEL OPERATION

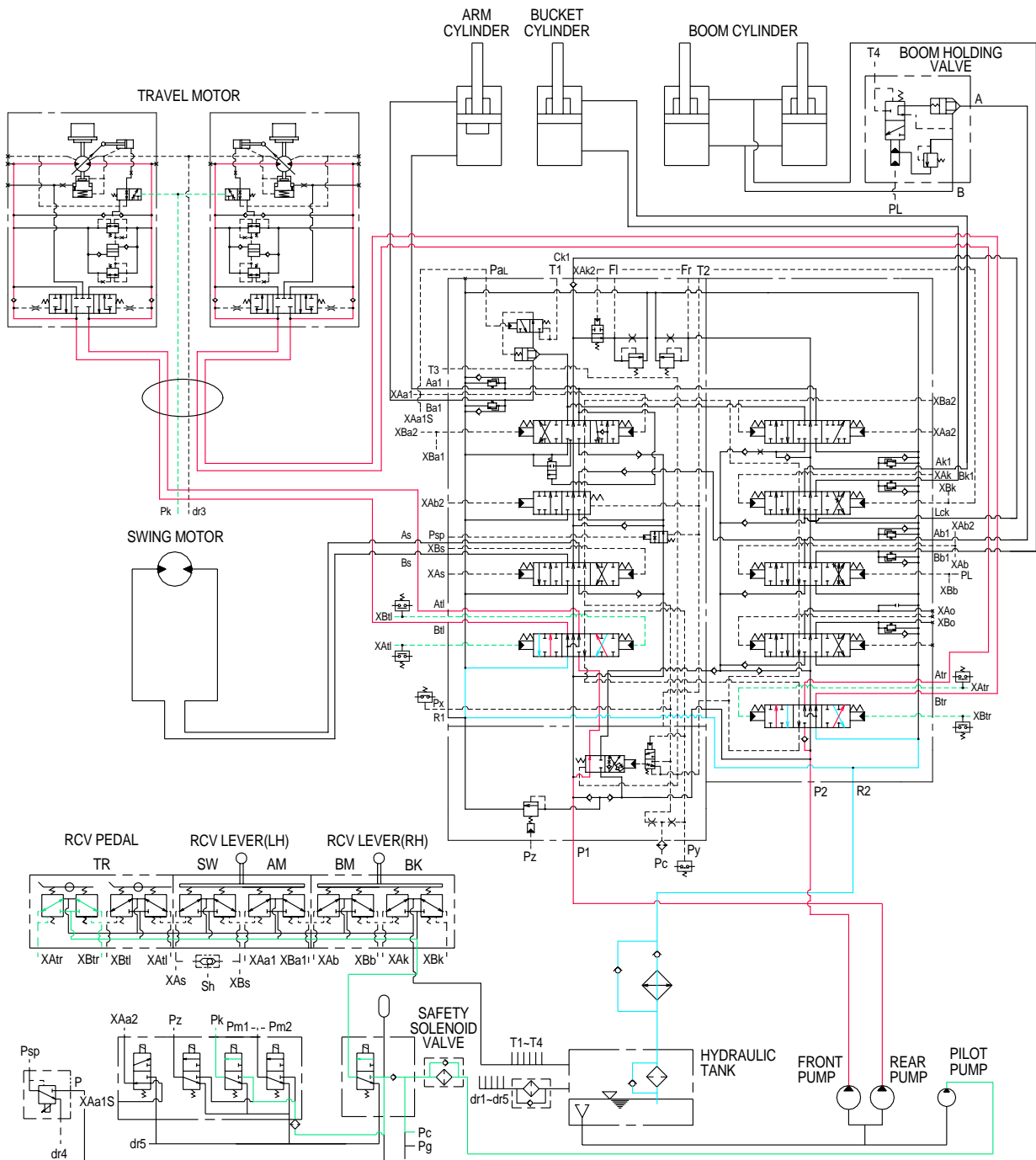

When the travel levers are pushed forward or reverse position, the travel spools in the main control valve are moved to the forward or reverse travel position by the pilot oil pressure from the remote control valve.

The oil from the both pumps flows into the main control valve and then goes to the both travel motors through the turning joint.

The oil returned from both travel motors returns to the hydraulic oil tank through the turning joint and the travel spools in the main control valve.

When this happens, the machine moves to the forward or reverse.

TRAVEL CIRCUIT OPERATION

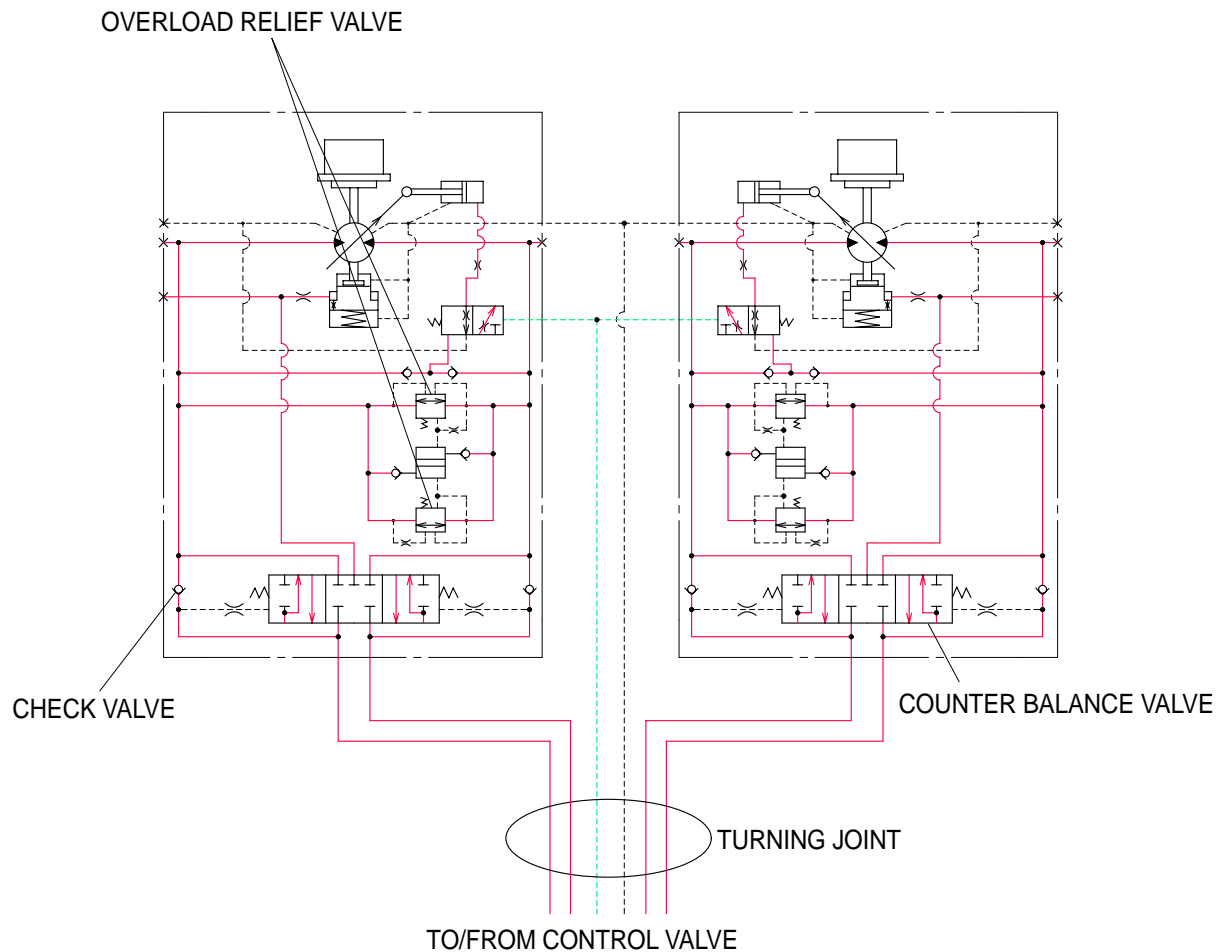

Brake valves are provided on travel motors to offer the following functions.

1) CHECK VALVE

This valve assists the counterbalance valve operation and prevent the cavitation of the motor.

2) COUNTER BALANCE VALVE

This valve prevents the motor from overrunning on the slope and blocks the circuits when stopping.

3) OVERLOAD RELIEF VALVE

Relief valve limits the circuit pressure below 350kgf/cm^2 to prevent overload of the motor.