

GROUP 4 MAIN CONTROL VALVE

1. REMOVAL AND INSTALL

1) REMOVAL

- (1) Lower the work equipment to the ground and stop the engine.
- (2) Operate the control levers and pedals several times to release the remaining pressure in the hydraulic piping.
- (3) Loosen the breather slowly to release the pressure inside the hydraulic tank.
 - ▲ Escaping fluid under pressure can penetrate the skin causing serious injury.
 - ※ When pipes and hoses are disconnected, the oil inside the piping will flow out, so catch it in oil pan.
- (4) Remove bolts and disconnect pipe.
- (5) Disconnect pilot line hoses.
- (6) Disconnect pilot piping.
- (7) Sling the control valve assembly and remove the control valve mounting bolt.
 - Weight : 193kg(426lb)

- (8) Remove the control valve assembly.
 - ※ When removing the control valve assembly, check that all the piping have been disconnected.

2) INSTALL

- (1) Carry out installation in the reverse order to removal.
- (2) Bleed the air from below items.
 - ① Cylinder(Boom, arm, bucket)
 - ② Swing motor
 - ③ Travel motor
 - ※ See each item removal and install.
- (3) Confirm the hydraulic oil level and recheck the hydraulic oil leak or not.

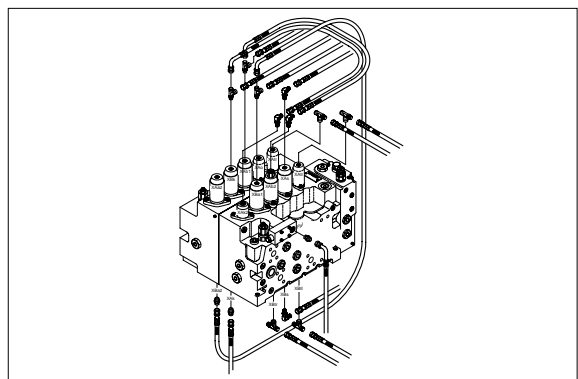
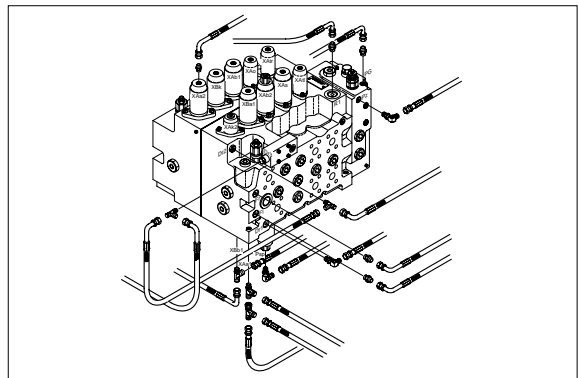
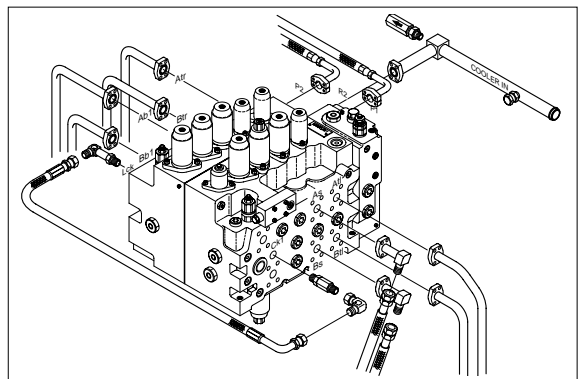

2. STRUCTURE(1/3)

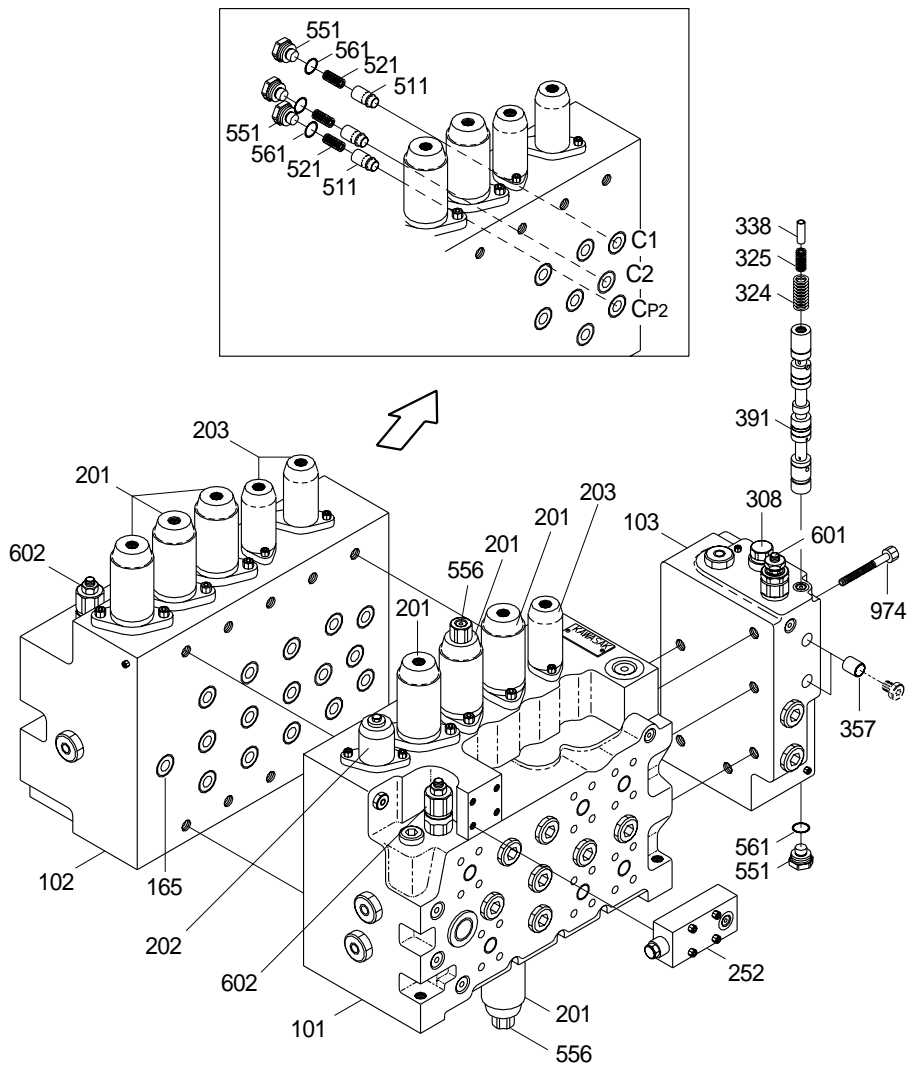

101	Casing A	252	Lock valve	515	Poppet
102	Casing B	308	Arm confluence spool	551	Plug
103	Straight travel block	324	Spring	556	Plug
165	O-ring	325	Spring	561	O-ring
201	Cover	338	Stopper	601	Relief valve assembly
202	Cover	357	Orifice	602	Port relief valve
203	Cover	391	Straight travel spool	974	Socket screw

STRUCTURE(2/3)

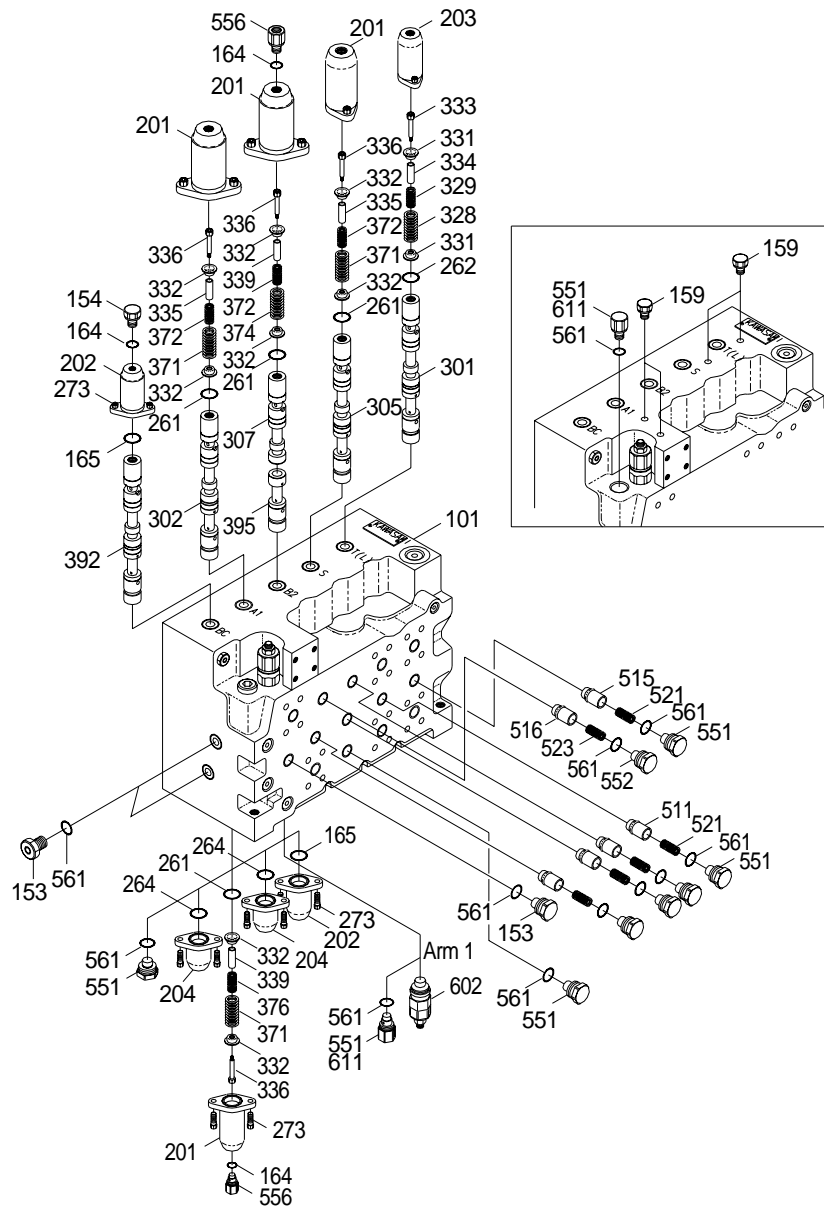

101	Casing A	302	Arm 1 spool	376	Spring
153	Plug	305	Swing spool	392	Rod
154	Plug	307	Boom 2 spool	395	Swing priority spool
159	Plug	328	Spring	511	Poppet
164	O-ring	329	Spring	515	Poppet
165	O-ring	331	Seat	516	Poppet
201	Cover	332	Seat	521	Spring
202	Cover	333	Bolt	523	Spring
203	Cover	334	Stopper	551	Plug
204	Cover	335	Stopper	552	Plug
261	O-ring	336	Bolt	556	Plug
262	O-ring	339	Stopper	561	O-ring
264	O-ring	371	Spring	602	Port relief valve
273	Socket screw	372	Spring	611	Negative relief valve
301	Spool	374	Spring		

STRUCTURE(3/3)

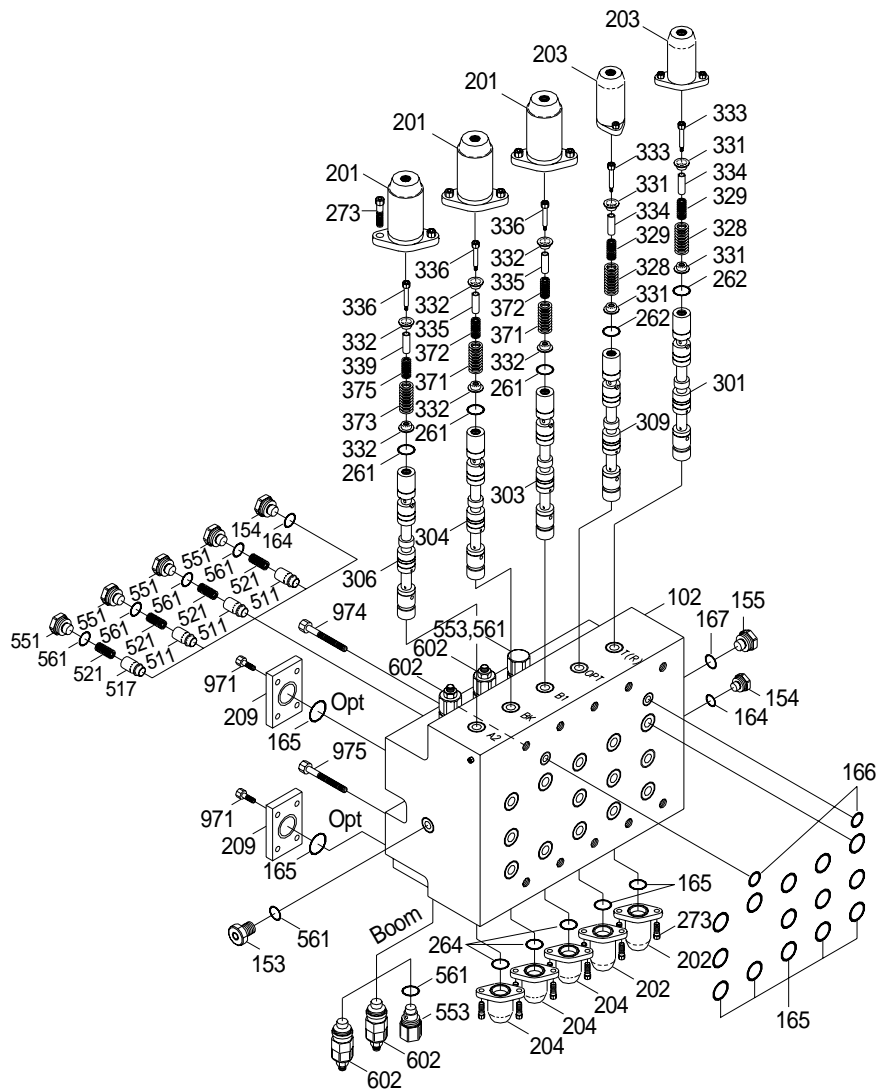

102	Casing B	264	O-ring	339	Stopper
153	Plug	273	Socket screw	371	Spring
154	Plug	301	Spool	372	Spring
155	Plug	303	Boom 1 spool	373	Spring
164	O-ring	304	Bucket spool	375	Spring
165	O-ring	306	Arm 2 spool	511	Poppet
166	O-ring	309	Option spool	517	Poppet
167	O-ring	328	Spring	521	Spring
201	Cover	329	Spring	551	Plug
202	Cover	331	Seat	553	Plug
203	Cover	332	Seat	561	O-ring
204	Cover	333	Bolt	602	Port relief valve
209	Flange	334	Stopper	971	Screw
261	O-ring	335	Stopper	974	Socket screw
262	O-ring	336	Bolt	975	Screw

1) MAIN RELIEF VALVE

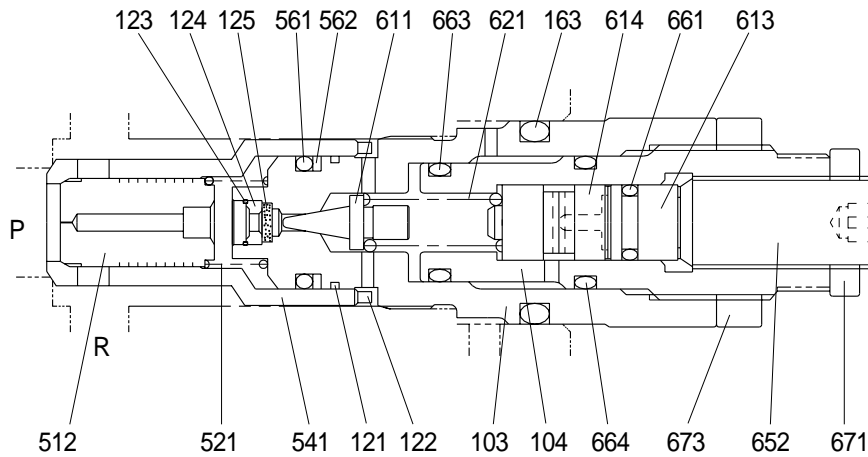

103	Plug	512	Plunger	621	Spring
104	Adjusting plug	521	Spring	652	Adjusting screw
121	O-ring	541	Seat	661	O-ring
122	Spacer	561	O-ring	663	O-ring
123	O-ring	562	Back up ring	664	O-ring
124	Filter stopper	611	Poppet	671	Lock nut
125	Filter	613	Stopper	673	Lock nut
163	O-ring	614	Piston		

2) PORT RELIEF VALVE

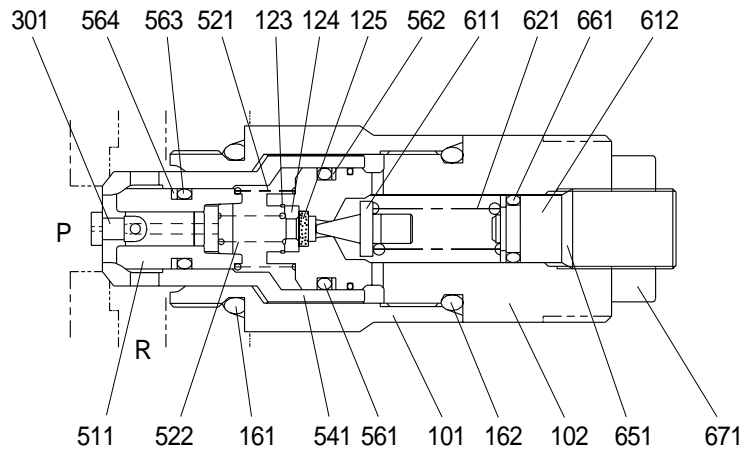

101	Body	511	Plunger	564	Back up ring
102	Plug	521	Spring	611	Poppet
123	O-ring	522	Spring	612	Spring seat
124	Filter stopper	541	Seat	621	Spring
125	Filter	561	O-ring	651	Adjusting screw
161	O-ring	562	Back up ring	661	O-ring
162	O-ring	563	O-ring	671	Lock nut
301	Piston				

3) STRAIGHT TRAVEL VALVE BLOCK

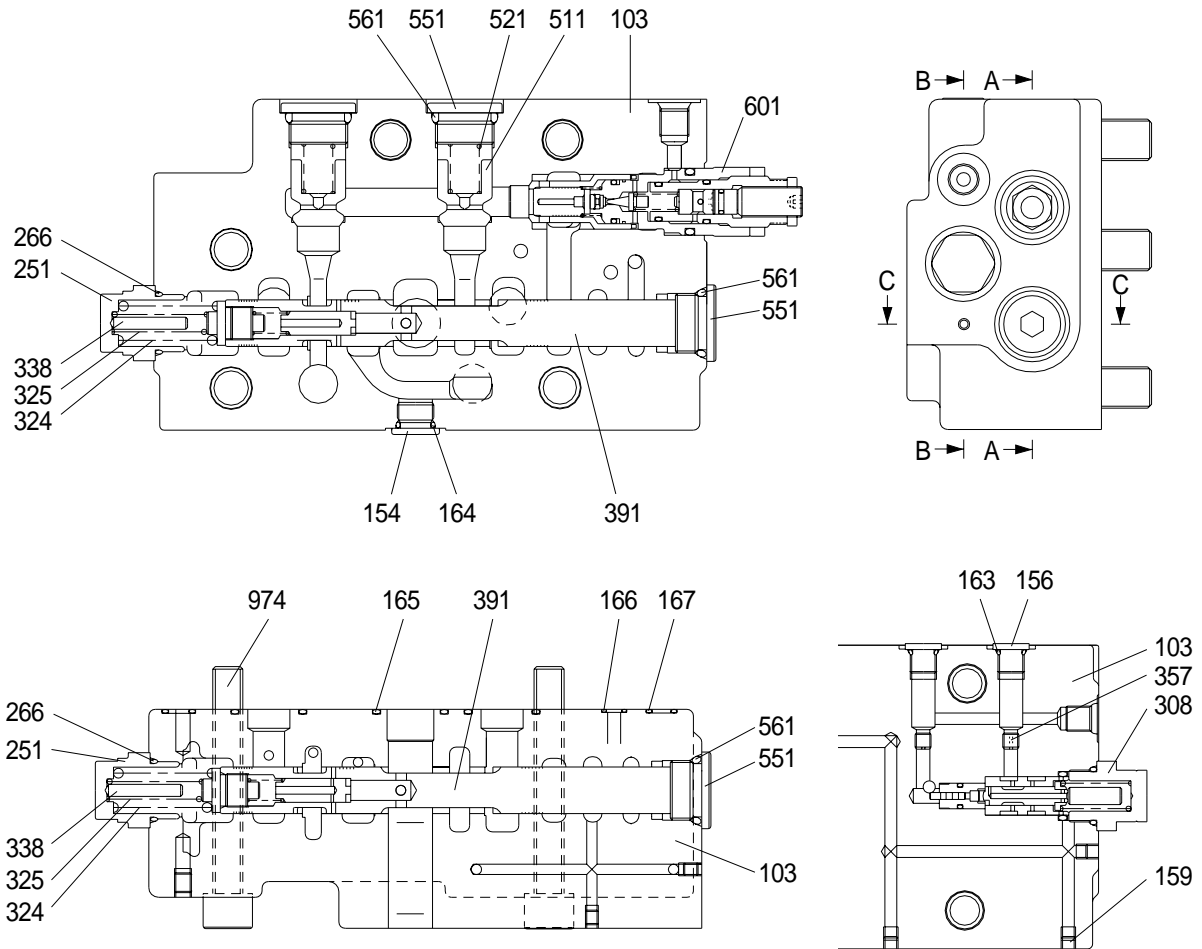

- | | | | | | |
|-----|-----------------------|-----|--------------|-----|----------------------------|
| 103 | Straight travel block | 167 | O-ring | 391 | Straight travel spool assy |
| 154 | RO plug | 251 | Plug | 511 | Poppet |
| 156 | RO plug | 266 | O-ring | 521 | Spring |
| 159 | Plug | 308 | Sequence sub | 551 | Plug |
| 163 | O-ring | 324 | Spring | 561 | O-ring |
| 164 | O-ring | 325 | Spring | 601 | Main relief valve |
| 165 | O-ring | 338 | Stopper | 974 | Hexagon socket bolt |
| 166 | O-ring | 357 | Orifice | | |

• Sequence sub(308)

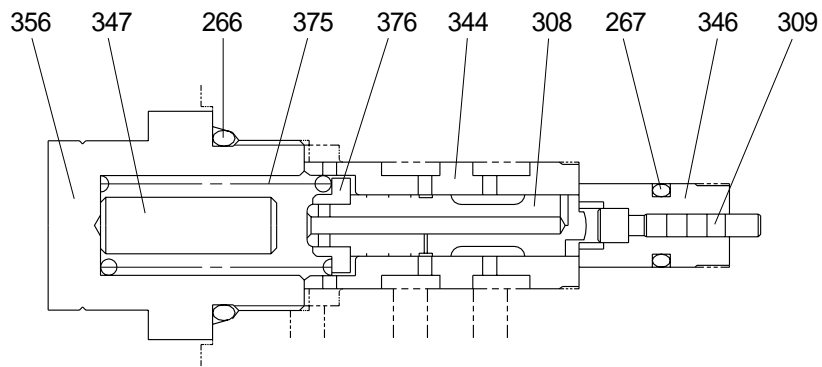

266	O-ring	344	Sleeve	356	Plug
267	O-ring	346	Bushing	375	Spring
308	Spool	347	Stopper	376	Spring seat
309	Piston				

4) ARM SPOOL

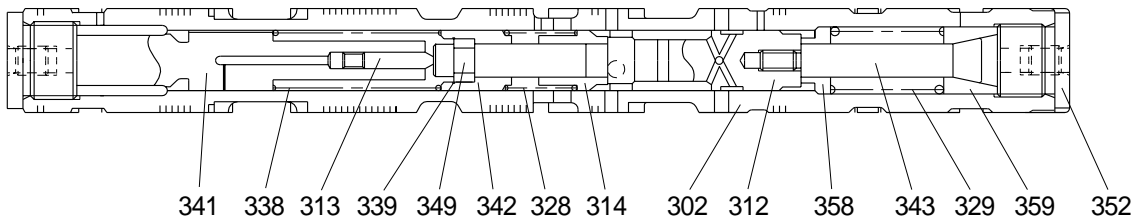

302	Spool	329	Spring A2	343	Spacer bolt
312	Sub spool	338	Spring	349	Stopper 1
313	Piston	339	C-ring	352	Plug
314	Sleeve 2	341	Plug	358	Spring seat
328	Spring A1	342	Sleeve 1	359	Spring seat

5) BOOM SPOOL

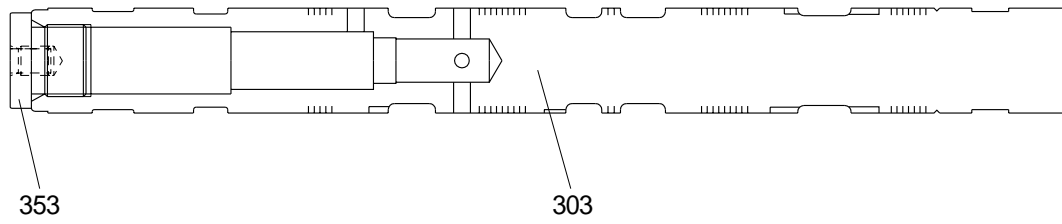

303 Spool

353 Plug

6) NEGATIVE CONTROL RELIEF VALVE

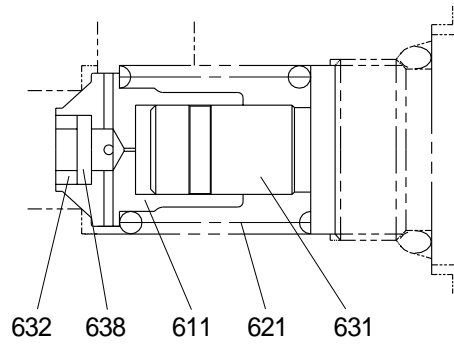

611 Poppet

621 Spring

631 Damping rod

632 Bushing

638 Filter

7) STRAIGHT TRAVEL SPOOL

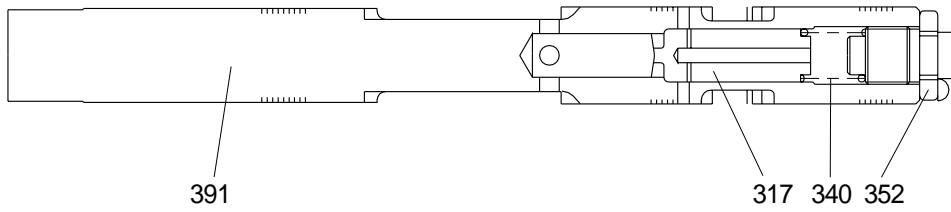

317	Plunger 3	352	Plug	391	Spool
340	Spring				

8) LOCK VALVE ASSEMBLY

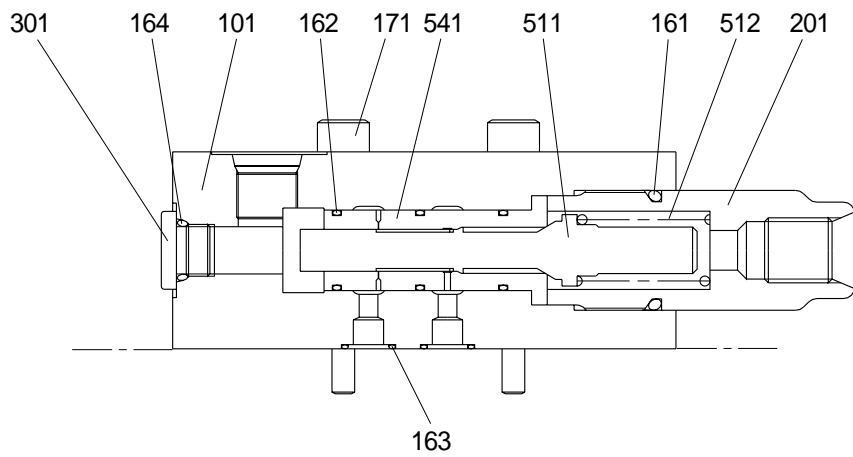

101	Casing	164	O-ring	511	Spol
161	O-ring	171	Hexagon socket bolt	512	Spring
162	O-ring	201	Plug	541	Bushing
163	O-ring	301	Plug		

3. TOOLS AND TIGHTENING TORQUES

1) TOOLS

Before disassembling the control valve, prepare the following tools beforehand.

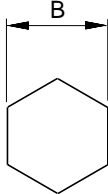
Tool name	Remark	
Vice bench	-	
Box wrench	27	
	30	
	32	
Hex key wrench	4	
	5	
	6	
	8	
	10	
	12	
	14	
Seal tape	-	
Loctite #241	-	
Spanner	32	

2) TIGHTENING TORQUE

Item No.	Part name	Torque	
		kgf · m	lbf · ft
101	Body	69.0 ~ 78.0	499 ~ 564
102	Plug	69.0 ~ 78.0	499 ~ 564
103	Plug	69.0 ~ 78.0	499 ~ 564
154	Plug	69.0 ~ 78.0	499 ~ 564
156	Plug	34.0 ~ 39.0	246 ~ 282
159	Plug	5.9 ~ 8.8	42.7 ~ 63.7
201	Plug	74.0	535
251	Plug	69.0 ~ 78.0	499 ~ 564
301	Plug	34.0 ~ 39.0	256 ~ 282
308	Sequence assy	69.0 ~ 78.0	499 ~ 564
341	Plug	59.0 ~ 69.0	427 ~ 499
343	Spacer bolt	9.8 ~ 11.8	70.9 ~ 85.3
352	Plug	59.0 ~ 69.0	427 ~ 499
353	Plug	59.0 ~ 69.0	427 ~ 499
356	Plug	69.0 ~ 78.0	499 ~ 564
357	Orifice	15.0 ~ 18.0	109 ~ 130
551	Plug	147 ~ 176	1063 ~ 1273
601	Main relief valve	69.0 ~ 78.0	499 ~ 564
671	Lock nut	27.0 ~ 31.0	195 ~ 224
673	Lock nut	27.0 ~ 31.0	195 ~ 224

4. DISASSEMBLY AND ASSEMBLY

1) PRECAUTION

- (1) All hydraulic components are worked with precision working. Then, before disassembling and assembling them, it is essential to select an especially clean place.
- (2) In handling a control valve, pay full attention to prevent dust, sand, etc. from entering into it.
- (3) When a control valve is to be removed from the machine, apply caps to all ports.
Before disassembling the valve, recheck that these caps are fitted completely, and then clean the outside of the assembly. Use a proper bench for working, spread a paper or rubber mat on the bench, and disassemble the valve on it.
- (4) Support the body section carefully in carrying, transferring and so on of the control valve. Do not support the lever, exposed spool, end cover section or so on without fail.
- (5) After disassembling and assembling of the component it is desired to carry out various tests (For the relief characteristics, leakage, flow resistance, etc.), but the hydraulic test equipment is necessary to these tests.
Therefore, even when its disassembling can be carried out technically, do not disassemble such component that cannot be tested, adjusted, and so on.
Besides, prepare clean cleaning oil, hydraulic oil, grease, etc. beforehand.

2) DISASSEMBLING

The figure in () shown after the part name in the explanation sentence shows its number in the structure figures at page 8-31 to 8-38.

- (1) Place control valve on working bench.
※ Disassemble it in clean place and pay attention not to damage flange face.

(2) Removal of straight travel valve block

● Removal

Loosen hexagon socket head bolts to remove straight travel valve block (103) in its assembled stated.

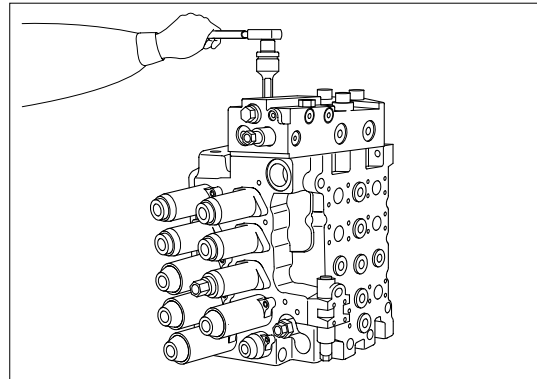

● Disassembling

- ① Hold casing(103) with vice.
- ② Remove plug(251) and pull out springs (324, 325), stopper(338) and straight travel spool assembly(391).
- ③ Remove plug(551) and pull out poppet (511) and spring(521).
- ④ Remove main relief valve(601).
(Disassemble main relief valve as shown in the following.)

(3) Disassembling of main relief valve

- ① Since plug(103) and seat(541) are fixed with C-ring(121), pull them out to remove them.
 - ② Take out spring(521) and plunger(512) from inside of seat(541).
 - ③ Remove lock nut(671) and adjusting screw(652) of adjusting plug(104) and take out stopper(613), piston(614), spring (621) and poppet(611).
 - ④ Loosen lock nut(673) of plug(103) and remove adjusting plug (104).
 - ⑤ Remove O-ring(121) and spacer(122) from plug(103).
- ※ Since filter(125) and filter stopper(124) are assembled to plug(103) with O-ring (123), do not disassemble them more than these conditions.

(4) Disassembling of travel spool

- ① Loosen hexagon socket head bolts(273) and remove spring cover(203).

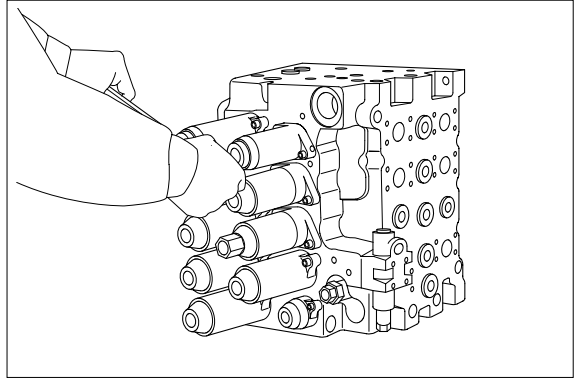

- ② Remove travel spool(301), springs(328, 329), spring seat(331), stopper(334) and spacer bolt(333) in spool assembly condition from casing.

※ When pulling out spool assembly from casing, pay attention not to damage casing.

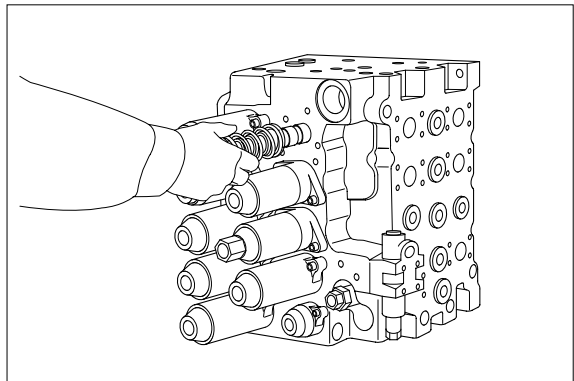

- ③ Hold travel spool(301) in mouthpiece-attached vise. Remove spacer bolt(333) and disassemble springs(328, 329), spring seat(331) and stopper(334).

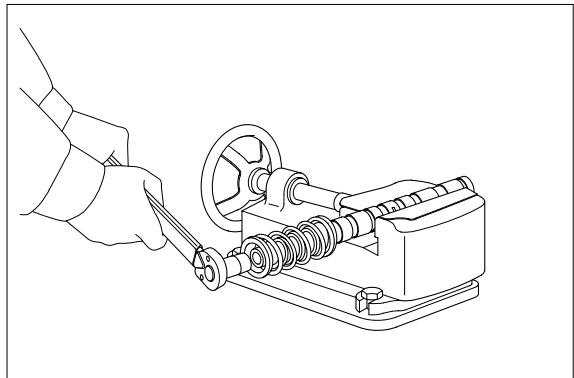

(5) Disassembling of arm spool

- ① Loosen hexagon socket head bolts(273) and remove arm cover(206).

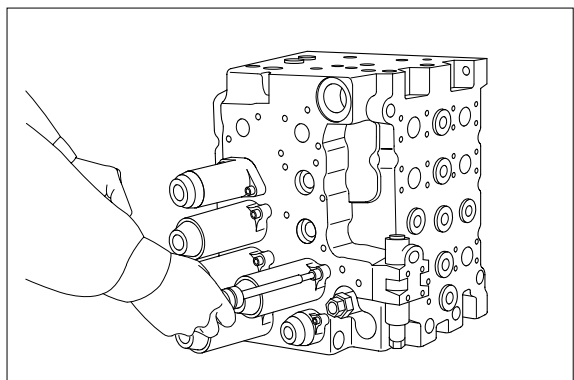

- ② Remove arm spool(302), springs(371, 372), spring seat(332), stopper(335) and spacer bolt(336) in spool assembly condition from casing.

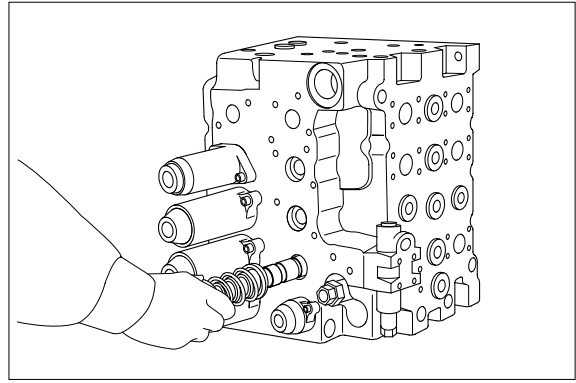

- ③ Hold arm spool(302) in mouthpiece-attached vise. Remove spacer bolt(336) and disassemble springs(371, 372), spring seat(332) and stopper(335).

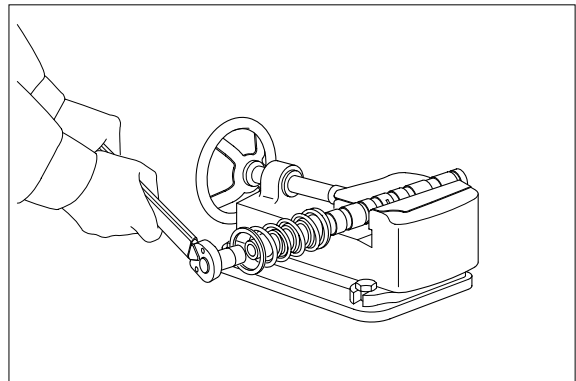

- ④ Except when there is any problem specially, do not disassemble arm spool (302) more than these conditions. If this is necessary at any cost, disassemble it in the following procedures.

- Hold middle section of arm spool(302) in mouthpiece-attached vise and remove plugs(352, 341) from its both ends.
 - Remove plugs(352, 341) and pull out sub-spool(312) in assembly condition. Remove piston(313) being fitted to plug (341).
 - Hold sub-spool(312) in mouthpiece-attached vise, remove space bolt(343) and take out spring(329) and spring seats(358, 359).
- ※ Pay attention not to damage sub-spool (312).
- Since sub-spool(312), sleeve 2(314), spring(328), sleeve 1(342), stopper(349) and C-ring(339) are assembled in one, do not disassemble them more than these conditions.

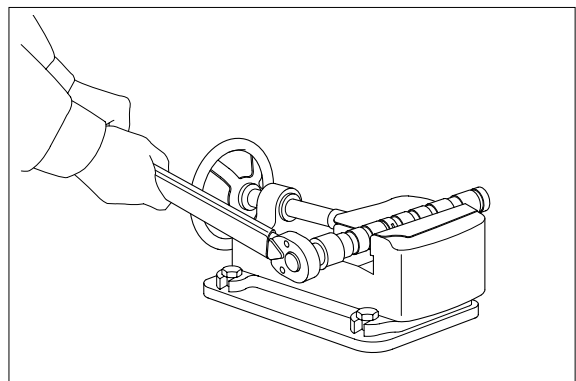

(6) Disassembling of boom spool

① Loosen hexagon socket head bolts(273), remove spring cover(201), and pull out boom spool(303), springs(371, 372), spring seat(332), stopper(335) and spacer bolt(336) in spool assembly condition from casing.

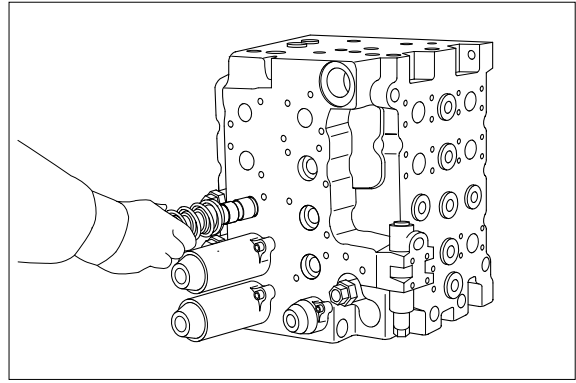

② Hold plug of spool assembly end in vise, remove spacer bolt(336), and disassemble springs(371, 372), spring seat(332) and stopper(335).

③ Except when there is any problem specially, do not disassemble boom spool sub(303) more than these conditions. If this is necessary at any cost, disassemble it in the following procedures.

- Hold middle section of boom spool(303) in mouthpiece-attached vise and remove plug(353).

※ Pay attention not to deform boom spool sub(303) by over tightening vise.

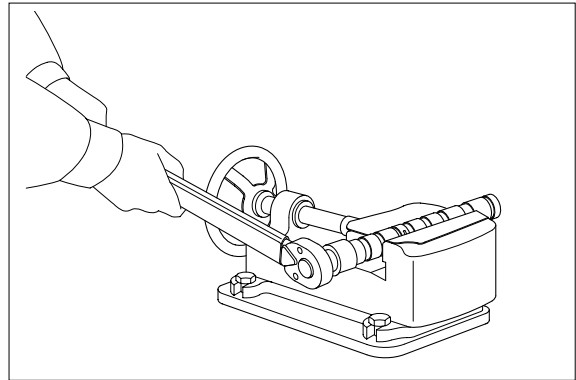

(7) Disassembly of covers

① Remove hexagon socket head bolts (273), and remove spool cover(202).

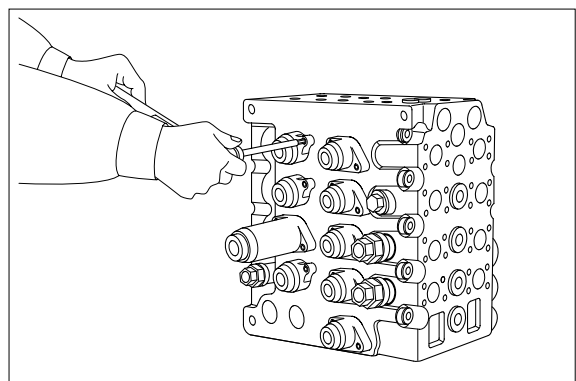

(8) Removal of port relief valve

● Removal

Remove port relief valve(602) from casing.

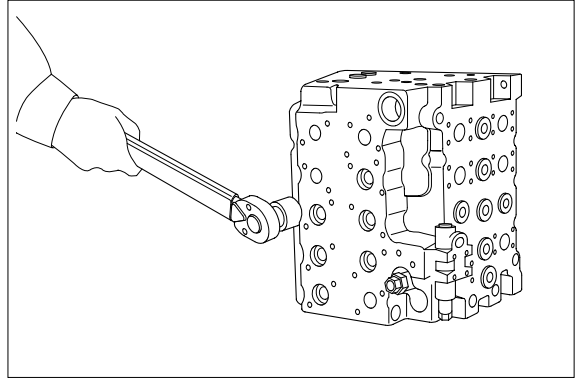

● Disassembling

- ① Loosen plug(102), remove springs(521, 522) and seat(541) from inside of body (101) and take out piston(301) and plunger(511) from inside of seat(541).

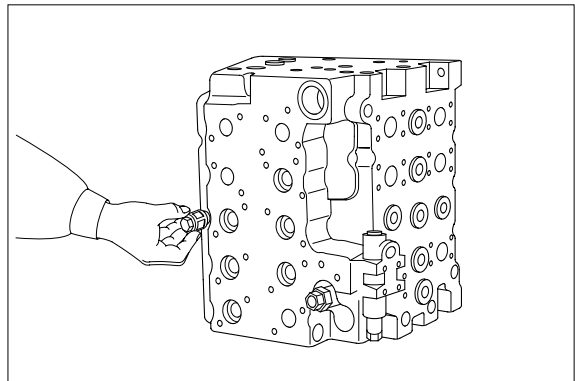

- ② Remove lock nut(671) and adjusting screw(651) of plug(102) and take out spring seat(612), spring(621) and poppet (611).

Since filter(125) and filter stopper(124) are assembled to plug(102) with O-ring (123), do not disassemble them more than these conditions.

(9) Removal of lock valve assembly

Loosen hexagon socket head bolts and remove lock valve assembly(252).

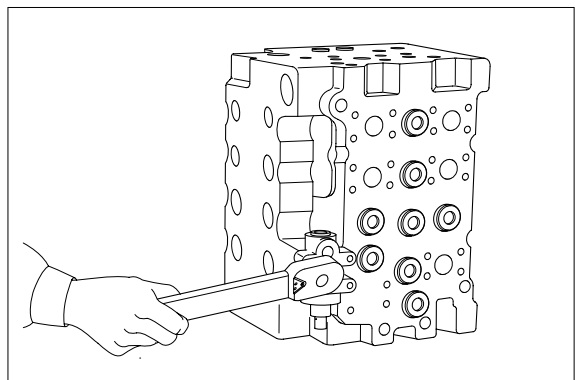

(10) Disassembly of negative control relief valve

- ① Remove plug(551).

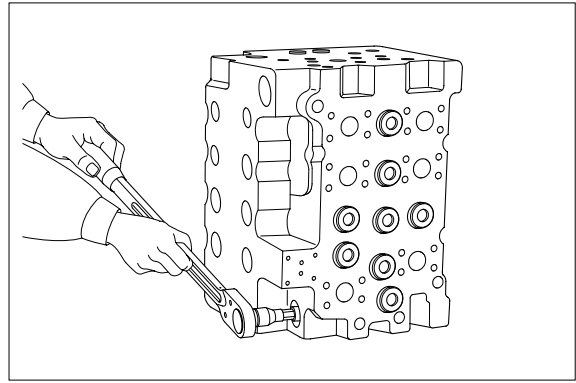

- ② Remove poppet(611), spring(621) and damping rod(631).

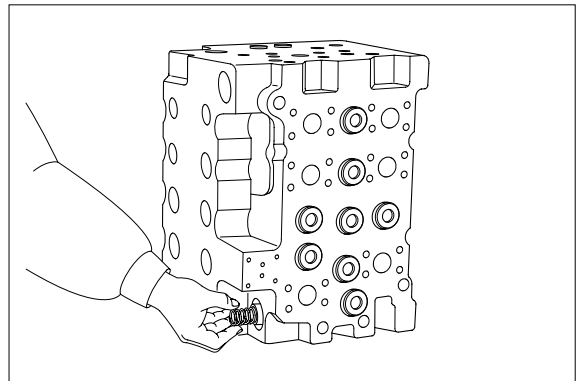

(11) Disassembly of check valve

- Remove plug(551) and take out poppet (511) and spring(521).

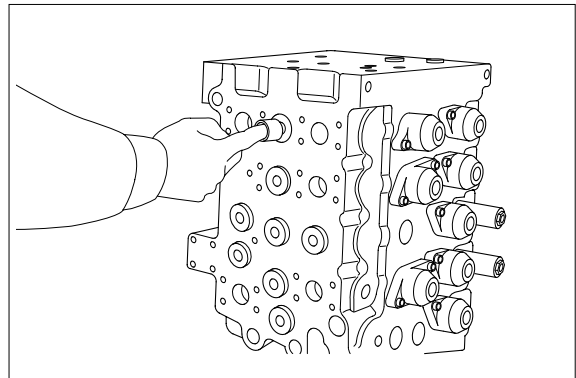

(12) Disassembly of casing

- ① Except when required specially, do not disassemble tie bolts of casing A and B.
- ② Since plugs not described in above disassembling procedures are blind plugs for sacrifice holes and blind plugs for casting sanitation, do not disassemble them as far as not required specially.

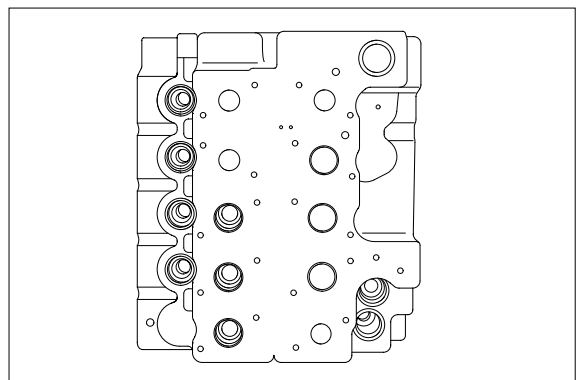

3) INSPECTION AFTER DISASSEMBLING

Clean all disassembled parts with clean mineral oil fully, and dry them with compressed air. Then, place them on clean papers or cloths for inspection.

(1) Control valve

- ① Check whole surfaces of all parts for burrs, scratches, notches and other defects.
- ② Confirm that seal groove faces of casing and block are smooth and free of dust, dent, rust etc.
- ③ Correct dents and damages on check seat faces of casing and block, if any, by lapping.
※ Pay attention not to leave lapping agent in casing and block.
- ④ Confirm that all sliding and fitting parts can be moved manually and that all grooves and paths are free foreign matter.
- ⑤ If any spring is broken or deformed, replace it with new one.
- ⑥ When relief valve do not function properly, repair it, following its disassembling assembling procedures.
- ⑦ Replace all seals and O-rings with new ones.

(2) Relief valve

- ① Confirm that all seat faces at ends of all poppets and seats are free of defects and are uniform contact faces.
- ② Confirm manually that main poppet and seat can slide lightly and smoothly.
- ③ Confirm that outside face of main poppet and inside face of seat are free from scratches and so on.
- ④ Confirms that springs are free from breaking, deformation, and wear.
- ⑤ Confirm that orifices of main poppet and seat section are not clogged with foreign matter.
- ⑥ Replace all O-rings with new ones.
- ⑦ When any light damage is found in above inspections, correct it by lapping.
- ⑧ When any abnormal part is found, replace it as relief valve assembly.

4) ASSEMBLING

- ※ In this assembling section, explanation only is shown. Refer to figures shown in disassembling section and structure section.
- ※ Figure in () shown after part name in explanation sentence shows number in structure figure.
- ※ **Cautions in assembling seals**
 - Pay attention to keep seals free from defects in its forming and damages in its handling.
 - Apply grease, hydraulic oil or so on to seals and seal-fitting sections for full lubrication.
 - Do not stretch seals so much to deform them permanently.
 - In fitting O-ring, pay attention not to roll it into its position. In addition, twisted O-ring cannot remove its twisting naturally with ease after being fitted, and causes oil leakage.
 - Tighten fitting bolts at all sections with torque wrench to their respective tightening torques.

(1) Assembling of casing

Fit O-rings(164, 165) to Casing A(101) and Casing B(102) and tighten bolts(974, 975) to specified torques.

- ※ Check mating faces for dust, etc. and confirm that O-rings are fitted to O-ring grooves securely.

(2) Assembly of plug

Tighten plug(159) to specified torque.

- ※ Since plug(159) is applied with special coating, use new one in reassembling without fail. However, in case of emergency, PT 1/8 plug available on market can be used substitutively with seal tape turned in one turn and half on it.
In this case pay full attention not to fall piece of seal tape into casing.
- ※ Use of seal tape may cause malfunction of control valve. Do not use it as far as possible.

(3) Assembly of check valve

Assemble poppets(511, 515, 516, 517) and tighten the latters to their specified torques.

- ※ Use poppets, springs and plugs in following groups.

Poppet	Poppet	Poppet
511	521	551
517	521	551
515	521	551
516	523	552

Remember that

- 511 in 10 positions

- 515 in 1 position and 516 in 1 position

(4) Assembling of negative control relief valve

Assemble poppet(611), spring(621) and damping rod(631) to casing A(101). Put O-ring(561) onto plug(551) and tighten the latter to its specified torque.

(5) Assembling of lock valve assembly

Fit O-ring(163) to lock valve assembly(252) and tighten hexagon socket head bolts to specified torque.

(6) Assembling of port relief valve

Assembling port relief valve(602) to casing and tighten it to specified torque.

- ※ Assembling procedures for relief valve itself are to be as shown in the following.
- Fit O-rings(162, 561) and back up ring(562) to plug(102). Fit poppet(611), spring(621) and O-ring (661) to spring seat(612). Then, assemble spring seat(612) into plug(102) temporarily with adjusting screw(651) and lock nut(671).
- ※ Confirm that poppet(611) has been fitted to seat section of plug(102) securely.
- Fit O-ring(563) and back up ring(564) to seat(541) of plunger(511). Then, assemble plunger (511), piston(301) and springs(521, 522)
- Fit seat(541) assembly to body(101) and tighten plug(102) assembly to specified torque.
- ※ Confirm that springs(521, 522) are guided securely.
- Since pressure adjustment is carried out according to **maintenance standards**, keep adjusting screw(651) as being assembled temporarily.

(7) Assembling of boom spool

- ① Tighten plug(353) to boom spool(303).
 - ② Hold boom spool in vise, set spring seat(332), springs(371, 372), stopper(335) and tighten spacer bolt(336) to specified torque.
- ※ Before tightening spacer bolt(336), apply Loctite #241 to it.
- ③ Fit spool assemblies of Items ① and ② above into Casing B(102).
- ※ Fit spool assemblies into Casing B(102) carefully and slowly. Do not push them forcibly without fail.

(8) Assembling of arm spool

- ① Hold arm sub-spool(312) in mouthpiece -attached vise, fit spring(329), spring seats(358, 359) and tighten spacer bolt(343) to specified torque.
- ※ Before tightening spacer bolt(343), apply Loctite #241 to it.
- ② Insert arm sub-spool(312) assembly into arm spool(302), paying attention not to insert it in wrong direction.
- Confirm that piston(313) has been inserted in plug(341), fit the latter and tighten it to specified torque.
- ※ Confirm that arm sub-spool(312) can move lightly in arm spool(302).
- ③ Hold plug(341) at end of arm spool(302) in vise, set spring seat(332), springs(371, 372) and stopper (335), and tighten spacer bolt(336) to specified torque.
- ※ Before tightening spacer bolt(336), apply loctite #241 to it.
- ④ Fit spool assemblies of Items ① and ② above into Casing A(102).
- ※ Fit spool assemblies into Casing A(101) carefully and slowly. Do not push them forcibly without fail.

(9) Assembling of travel spool

- ① Hold end of travel spool(301) in mouthpiece attached vise, set spring seat(331), springs(328, 329) and stopper(334), and tighten spacer bolt(333) to specified torque.
- ※ Before tightening spacer bolt(333), apply Loctite #241 to it.
- ② Insert spool assemblies into Casing A(101) and Casing B(102).
- ※ Fit spool assemblies into Casing A(101) and Casing B(102) carefully and slowly. Do not push them forcibly without fail.

(10) Assembling of covers

- ① Fit spool covers(202, 204) to sides reverse to spring sides of travel, option, swing, arm 1, boom 1, bucket and arm 2 spools and tighten hexagon socket head bolts(273) to specified torque.
 - ※ Confirm that O-rings(165, 264) have been fitted.
- ② Fit spring covers(203, 201) to spring sides of travel, option, bypass cut, swing, boom 2, arm 1, bucket, swing preferential boom, and arm 2 spools and tighten hexagon socket head bolts(273) to specified torque.
 - ※ Confirm that O-ring(261 & 262) have been fitted.

(11) Assembling of straight travel valve block

Fit O-rings(165, 166, 167, 266) to straight travel valve block(103) and tighten hexagon socket head bolt to specified torque.

- ※ Assembling procedures for straight travel valve block itself are to be as shown in the following.
 - Hold casing(103) in vise.
 - Fit main relief valve(601) to casing and tighten it to specified torque.
(Assembling procedures for main relief valve itself are shown separately.)
 - Fit poppet(511) and spring(521), and tighten plug(551) to specified torque.
 - Tighten orifice(357) with hexagon wrench to specified torque. Further, fit O-ring(163) to plug(156) and tighten plug to specified torque.
 - Fit piston(309), spool(308), sleeve(344), spring seat(376) and spring(375), paying attention not to fit them in wrong direction. Then, fit O-ring(266) to plug(356) and tighten plug to specified torque.
 - Fit spool(391), springs(324, 325) and stopper(338). Fit O-ring(266) to plug(251) and tighten plug to specified torque.

(12) Assembling of main relief valve

- ① Fit spacer(122), O-rings(121, 163, 561) and back up ring(562) to plug(103).
- ② Fit piston(614) and O-ring(661) to stopper(613). Fit them to adjusting plug(104) and assemble them temporarily with adjusting screw(652) and lock nut(671).
- ③ Fit poppet(611) and spring(621) to plug(103) and fit adjusting plug(104) fitted with O-ring(663, 664).
 - ※ Confirm that poppet(611) has been fitted to seat section of plug(103) securely.
- ④ Fit plunger(512) and spring(521) to seat(541).
- ⑤ Fit seat to plug(103) assembly and fix it with O-ring(121).
- ⑥ Since pressure adjustment is carried out according to **maintenance standards**, keep adjusting plug(104) and adjusting screw(652) as being assembled temporarily.