

GROUP 2 SPECIFICATIONS

1. MAJOR COMPONENT

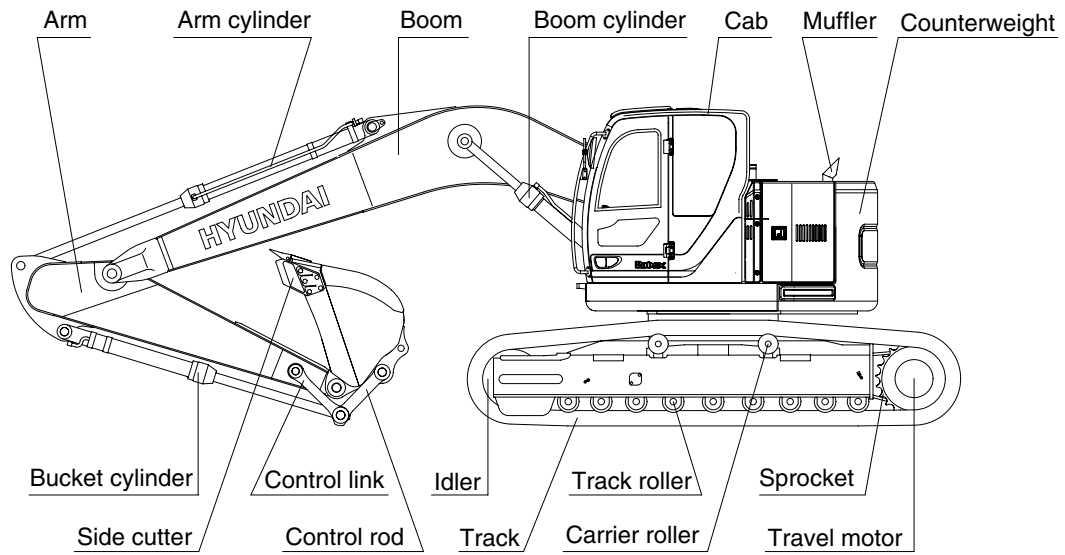
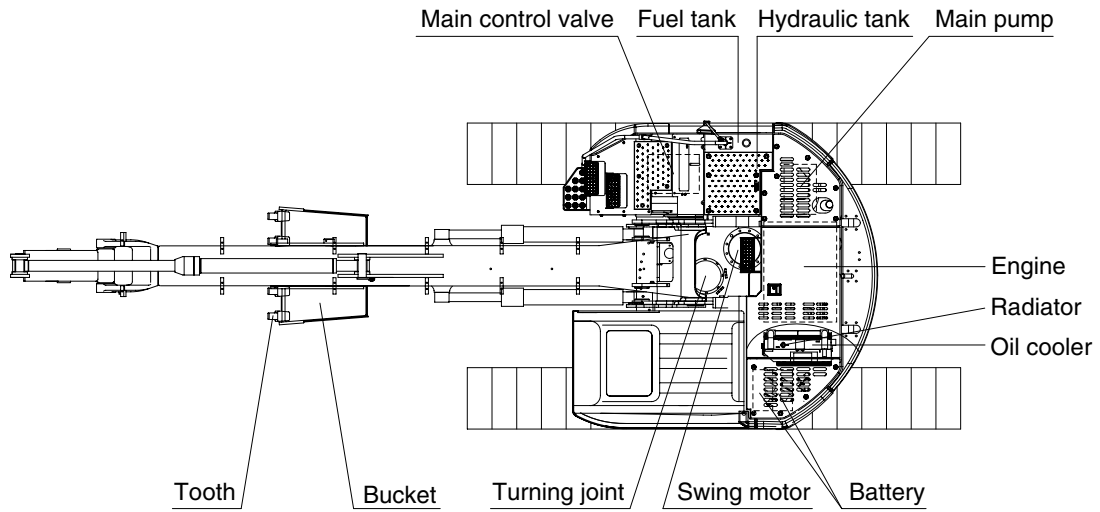

235Z92SP01

2. SPECIFICATIONS

1) R235LCR-9

· 5.68 m (18' 8") BOOM and 2.92 m (9' 7") ARM

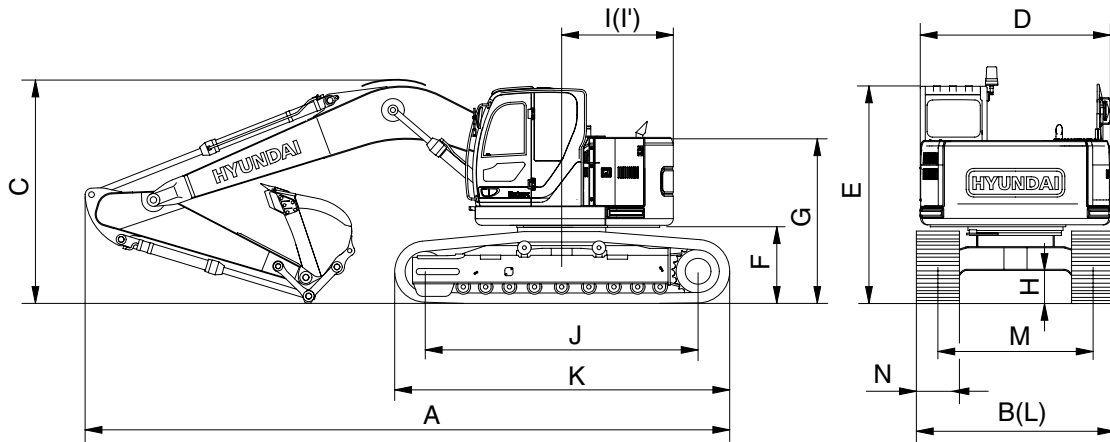

235Z92SP02

Description		Unit	Specification
Operating weight		kg (lb)	23800 (52470)
Bucket capacity (SAE heaped), standard		m ³ (yd ³)	0.8 (1.05)
Overall length	A	mm (ft-in)	8910 (29' 3")
Overall width, with 600mm shoe	B		2990 (9' 10")
Overall height	C		3020 (9' 11")
Superstructure width	D		2980 (9' 9")
Overall height of cab	E		2950 (9' 8")
Ground clearance of counterweight	F		1060 (3' 6")
Engine cover height	G		2385 (7' 10")
Minimum ground clearance	H		480 (1' 7")
Rear-end distance	I		1680 (5' 6")
Rear-end swing radius	I'		1680 (5' 6")
Distance between tumblers	J		3650 (12' 0")
Undercarriage length	K		4440 (14' 7")
Undercarriage width	L		2990 (9' 10")
Track gauge	M		2390 (7' 10")
Track shoe width, standard	N		600 (24")
Travel speed (low/high)			km/hr (mph)
Swing speed		rpm	12.0
Gradeability		Degree (%)	35 (70)
Ground pressure (600 mm shoe)		kgf/cm ² (psi)	0.51 (7.25)
Max traction force		kg (lb)	21100 (46500)

3. WORKING RANGE

1) R235LCR-9

· 5.68 m (18' 8") BOOM

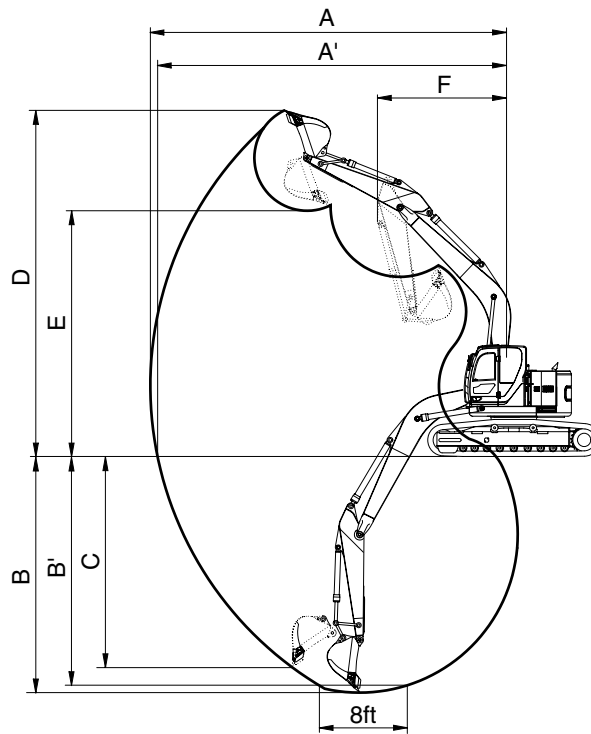

235Z92SP03

Description		2.0 m (6' 7") Arm	2.40 m (7' 10") Arm	2.92 m (9' 7") Arm
Max digging reach	A	9040 mm (29' 8")	9430 mm (30' 11")	9910 mm (32' 6")
Max digging reach on ground	A'	8860 mm (29' 1")	9260 mm (30' 5")	9750 mm (32' 0")
Max digging depth	B	5780 mm (19' 0")	6180 mm (20' 3")	6700 mm (22' 0")
Max digging depth (8 ft level)	B'	5550 mm (18' 3")	5980 mm (19' 7")	6530 mm (21' 5")
Max vertical wall digging depth	C	5140 mm (16' 10")	5710 mm (18' 9")	6270 mm (20' 7")
Max digging height	D	10090 mm (33' 1")	10420 mm (34' 2")	10830 mm (35' 6")
Max dumping height	E	7190 mm (23' 7")	7510 mm (24' 8")	7890 mm (25' 11")
Min swing radius	F	2860 mm (9' 5")	2550 mm (8' 4")	2350 mm (7' 9")
Bucket digging force	SAE	133.4 [144.8] kN		
		13600 [14770] kgf		
		29980 [32550] lbf		
	ISO	152.0 [165.0] kN		
		15500 [16830] kgf		
		34170 [37100] lbf		
Arm digging force	SAE	144.2 [156.5] kN	119.6 [129.9] kN	102.0 [110.7] kN
		14700 [15960] kgf	12200 [13250] kgf	10400 [11290] kgf
		32410 [35190] lbf	26900 [29210] lbf	22930 [24900] lbf
	ISO	151.0 [164.0] kN	125.5 [136.3] kN	106.9 [116.1] kN
		15400 [16720] kgf	12800 [13900] kgf	10900 [11830] kgf
		33950 [36860] lbf	28220 [30640] lbf	24030 [26090] lbf

[] : Power boost

4. WEIGHT

1) R235LCR-9













Item	R235LCR-9	
	kg	lb
Upperstructure assembly	11100	24470
Main frame weld assembly	1930	4250
Engine assembly	560	1240
Main pump assembly	140	310
Main control valve assembly	220	485
Swing motor assembly	240	530
Hydraulic oil tank assembly	160	350
Fuel tank assembly	150	330
Counterweight	5600	12350
Cab assembly	450	990
Lower chassis assembly	8700	19180
Track frame weld assembly	2720	6000
Swing bearing	290	640
Travel motor assembly	300	660
Turning joint	55	120
Track recoil spring	140	310
Idler	170	370
Carrier roller	20	45
Track roller	40	90
Track-chain assembly (600 mm standard triple grouser shoe)	1350	2980
Front attachment assembly (5.68 m boom, 2.92 m arm, 0.8 m ³ SAE heaped bucket)	3965	8740
5.68 m boom assembly	1520	3350
2.92 m arm assembly	750	1650
0.8 m ³ SAE heaped bucket	700	1540
Boom cylinder assembly	180	400
Arm cylinder assembly	290	640
Bucket cylinder assembly	175	390
Bucket control link assembly	170	370

5. LIFTING CAPACITIES

1) R235LCR-9

(1) 5.68 m (18' 8") boom, 2.92 m (9' 7") arm equipped with 0.80 m³ (SAE heaped) bucket, 600 mm (24") triple grouser shoe without dozer blade.













·  : Rating over-front ·  : Rating over-side or 360 degree

Load point height		Load radius										At max. reach		
		1.5 m (5 ft)		3.0 m (10 ft)		4.5 m (15 ft)		6.0 m (20 ft)		7.5 m (25 ft)		Capacity	Reach	
														m (ft)
9.0 m (30.0 ft)	kg lb					*2970 *6550	*2970 *6550					*3620 *7980	*3620 *7980	6.12 (20.1)
7.5 m (25.0 ft)	kg lb							*3310 *7300	*3310 *7300			*3460 *7630	3180 7010	7.70 (25.3)
6.0 m (20.0 ft)	kg lb							*3770 *8310	*3770 *8310			*3430 *7560	2480 5470	8.66 (28.4)
4.5 m (15.0 ft)	kg lb					*4800 *10580	*4800 *10580	*4190 *9240	*4190 *9240	*3850 *8490	3140 6920	*3460 *7630	2120 4670	9.24 (30.3)
3.0 m (10.0 ft)	kg lb			*9720 *21430	*9720 *21430	*6230 *13730	*6230 *13730	*4850 *10690	4410 9720	*4150 *9150	3000 6510	*3510 *7740	1940 4280	9.52 (31.3)
1.5 m (5.0 ft)	kg lb			*9500 *20940	*9500 *20940	*7640 *16840	6400 14110	*5550 *12240	4100 9040	*4480 *9880	2850 6280	*3520 *7760	1880 4140	9.52 (31.3)
Ground Line	kg lb			*9890 *21800	*9890 *21800	*8440 *18610	6000 13230	*6040 *13320	3870 8530	*4710 *10380	2720 6000	*3640 *8020	1960 4320	9.24 (30.3)
-1.5 m (-5.0 ft)	kg lb	*8800 *19400	*8800 *19400	*12830 *28290	11650 25680	*8510 *18760	5840 12870	*6150 *13560	3750 8270	*4680 *10320	2660 5860	*3660 *8070	2190 4830	8.66 (28.4)
-3.0 m (-10 ft)	kg lb	*12230 *26960	*12230 *26960	*11420 *25180	*11420 *25180	*7880 *17370	5860 12920	*5730 *12630	3740 8250			*3550 *7830	2710 5970	7.69 (25.2)
-4.5 m (-15.0 ft)	kg lb			*8960 *19750	*8960 *19750	*6340 *13980	6030 13290					*2970 *6550	*2970 *6550	6.13 (20.0)

- Note
1. Lifting capacity are based on SAE J1097 and ISO 10567.
 2. Lifting capacity of the ROBEX series does not exceed 75% of tipping load with the machine on firm, level ground or 87% of full hydraulic capacity.
 3. The load point is a hook located on the back of the bucket.
 4. *indicates load limited by hydraulic capacity.

(2) 5.68 m (18' 8") boom, 2.92 m (9' 7") arm equipped with 0.80 m³ (SAE heaped) bucket, 600 mm (24") triple grouser shoe with dozer blade.

-  : Rating over-front
-  : Rating over-side or 360 degree

Load point height		Load radius										At max. reach				
		1.5 m (5 ft)		3.0 m (10 ft)		4.5 m (15 ft)		6.0 m (20 ft)		7.5 m (25 ft)		Capacity		Reach		
														Capacity	Reach	
9.0 m (30.0 ft)	kg					*2970	*2970							*3630	*3630	6.12
	lb					*6550	*6550							*8000	*8000	(20.1)
7.5 m (25.0 ft)	kg							*3310	*3310					*3460	*3460	7.70
	lb							*7300	*7300					*7630	*7630	(25.3)
6.0 m (20.0 ft)	kg							*3780	*3780					*3430	2880	8.66
	lb							*8330	*8330					*7560	6350	(28.4)
4.5 m (15.0 ft)	kg					*4810	*4810	*4190	*4190	*3860	3630	*3460	2490	9.24		
	lb					*10600	*10600	*9240	*9240	*8510	8000	*7630	5490	(30.3)		
3.0 m (10.0 ft)	kg			*9730	*9730	*6240	*6240	*4860	*4860	*4150	3490	*3512	2300	9.52		
	lb			*21450	*21450	*13760	*13760	*10710	*10710	*9150	7960	*7760	5270	(31.3)		
1.5 m (5.0 ft)	kg			*9500	*9500	*7650	7430	*5560	4770	*4490	3340	*3590	2250	9.52		
	lb			*20940	*20940	*16870	16380	*12260	10520	*9900	7360	*7910	4960	(31.3)		
Ground Line	kg			*9890	*9890	*8460	7020	*6050	4530	*4720	3210	*3650	2330	9.24		
	lb			*21800	*21800	*18650	15480	*13340	9990	*10410	7080	*8050	5140	(30.3)		
-1.5 m (-5.0 ft)	kg	*8800	*8800	*12860	*12860	*8530	6860	*6160	4410	*4690	3150	*3670	2600	8.66		
	lb	*19400	*19400	*28350	*25350	*18810	15120	*13580	9720	*10340	6940	*8090	5730	(28.4)		
-3.0 m (-10 ft)	kg	*12230	*12230	*11440	*11440	*7900	6880	*5740	4410			*3560	3190	7.69		
	lb	*26960	*26960	*25220	*25220	*17420	15170	*12650	9720			*7850	7030	(25.2)		
-4.5 m (-15.0 ft)	kg			*8990	*8990	*6360	*6060					*2980	*2980	6.13		
	lb			*19820	*19820	*14020	*14020					*6570	*6570	(20.0)		

- Note
1. Lifting capacity are based on SAE J1097 and ISO 10567.
 2. Lifting capacity of the ROBEX series does not exceed 75% of tipping load with the machine on firm, level ground or 87% of full hydraulic capacity.
 3. The load point is a hook located on the back of the bucket.
 4. *indicates load limited by hydraulic capacity.

6. BUCKET SELECTION GUIDE

1) GENERAL BUCKET

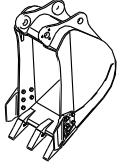
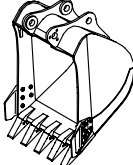
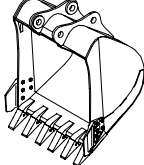
		
0.51 m ³ SAE heaped bucket	0.80, 0.87, 0.92, 1.10, 1.20 m ³ SAE heaped bucket	1.34 m ³ SAE heaped bucket

Capacity		Width		Weight	Recommendation		
					5.65 m (18' 6") Mono boom		
SAE heaped	CECE heaped	Without side cutter	With side cutter		2.0 m arm (6' 7")	2.4 m arm (7' 10")	2.92 m arm (9' 7")
0.51 m ³ (0.67 yd ³)	0.45 m ³ (0.59 yd ³)	700 mm (27.6")	820 mm (312.3)	570 kg (1260 lb)			
0.80 m ³ (1.05 yd ³)	0.70 m ³ (0.92 yd ³)	1000 mm (39.4")	1120 mm (44.1")	700 kg (1540 lb)			
0.87 m ³ (1.14 yd ³)	0.75 m ³ (0.98 yd ³)	1090 mm (42.9")	1210 mm (47.6")	740 kg (1630 lb)			
0.92 m ³ (1.20 yd ³)	0.80 m ³ (1.05 yd ³)	1150 mm (45.3")	1270 mm (50.0")	770 kg (1700 lb)			
1.10 m ³ (1.44 yd ³)	0.96 m ³ (1.26 yd ³)	1320 mm (52.0")	1440 mm (56.7")	830 kg (1830 lb)			
1.20 m ³ (1.57 yd ³)	1.00 m ³ (1.31 yd ³)	1400 mm (55.1")	1520 mm (60.0")	850 kg (1870 lb)			
1.34 m ³ (1.75 yd ³)	1.15 m ³ (1.50 yd ³)	1550 mm (61.0")	1670 mm (65.7")	920 kg (2030 lb)			

 Applicable for materials with density of 2000 kg/m³ (3370 lb/yd³) or less

 Applicable for materials with density of 1600 kg/m³ (2700 lb/yd³) or less

 Applicable for materials with density of 1100 kg/m³ (1850 lb/yd³) or less

2) HEAVY DUTY, ROCK-HEAVY DUTY AND SLOPE FINISHING BUCKET

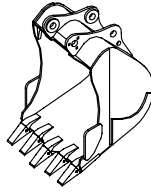
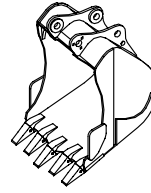
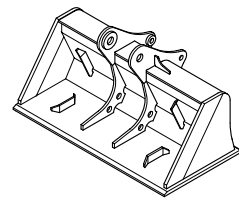
Heavy duty bucket	Rock-Heavy duty bucket	Slope finishing bucket
		
◆ 0.74, 0.90, 1.05 m ³ SAE heaped bucket	◎ 0.87 m ³ SAE heaped bucket	■ 0.75 m ³ SAE heaped bucket

Capacity		Width		Weight	Recommendation		
SAE heaped	SAE heaped	Without side cutter	With side cutter		5.65 m (18' 6") boom		
					2.0 m arm (6' 7")	2.4 m arm (7' 10")	2.92 m arm (9' 7")
◆ 0.74 m ³ (0.97 yd ³)	0.65 m ³ (0.85 yd ³)	985 mm (38.8")	-	770 kg (1700 lb)			
◆ 0.90 m ³ (1.18 yd ³)	0.80 m ³ (1.05 yd ³)	1070 mm (42.1")	-	810 kg (1790 lb)			
◆ 1.05 m ³ (1.37 yd ³)	0.92 m ³ (1.20 yd ³)	1290 mm (50.8")	-	890 kg (1960 lb)			
◎ 0.87 m ³ (1.14 yd ³)	0.75 m ³ (0.98 yd ³)	1140 mm (44.9")	-	900 kg (1980 lb)			
■ 0.75 m ³ (0.98 yd ³)	0.65 m ³ (0.85 yd ³)	1790 mm (70.5")	-	880 kg (1940 lb)			

◆ : Heavy duty bucket ◎ : Rock-Heavy duty bucket ■ : Slope finishing bucket

 Applicable for materials with density of 2000 kg/m³ (3370 lb/yd³) or less

 Applicable for materials with density of 1600 kg/m³ (2700 lb/yd³) or less

 Applicable for materials with density of 1100 kg/m³ (1850 lb/yd³) or less

7. UNDERCARRIAGE

1) TRACKS

X-leg type center frame is integrally welded with reinforced box-section track frames. The design includes dry tracks, lubricated rollers, idlers, sprockets, hydraulic track adjusters with shock absorbing springs and assembled track-type tractor shoes with triple grousers.

2) TYPES OF SHOES

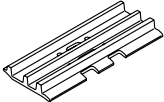
Model	Shapes		Triple grouser			
						
R235LCR-9	Shoe width	mm (in)	600 (24)	700 (28)	800 (32)	900 (36)
	Operating weight	kg (lb)	23800 (52470)	24150 (53240)	24415 (53830)	24680 (54410)
	Ground pressure	kgf/cm ² (psi)	0.51 (7.25)	0.44 (6.26)	0.39 (5.55)	0.35 (4.98)
	Overall width	mm (ft-in)	2990 (9' 10")	3090 (10' 2")	3190 (10' 6")	3290 (10' 10")

3) NUMBER OF ROLLERS AND SHOES ON EACH SIDE

Item	Quantity
Carrier rollers	2 EA
Track rollers	9 EA
Track shoes	49 EA

4) SELECTION OF TRACK SHOE

Suitable track shoes should be selected according to operating conditions.

Method of selecting shoes

Confirm the category from the list of applications in **table 2**, then use **table 1** to select the shoe. Wide shoes (categories B and C) have limitations on applications. Before using wide shoes, check the precautions, then investigate and study the operating conditions to confirm if these shoes are suitable.

Select the narrowest shoe possible to meet the required flotation and ground pressure. Application of wider shoes than recommendations will cause unexpected problem such as bending of shoes, crack of link, breakage of pin, loosening of shoe bolts and the other various problems.

※ **Table 1**

Track shoe	Specification	Category
600 mm triple grouser	Standard	A
700 mm triple grouser	Option	B
800 mm triple grouser	Option	C
900 mm triple grouser	Option	C

※ **Table 2**

Category	Applications	Precautions
A	Rocky ground, river beds, normal soil	<ul style="list-style-type: none"> • Travel at low speed on rough ground with large obstacles such as boulders or fallen trees
B	Normal soil, soft ground	<ul style="list-style-type: none"> • These shoes cannot be used on rough ground with large obstacles such as boulders or fallen trees • Travel at high speed only on flat ground • Travel slowly at low speed if it is impossible to avoid going over obstacles
C	Extremely soft ground (swampy ground)	<ul style="list-style-type: none"> • Use the shoes only in the conditions that the machine sinks and it is impossible to use the shoes of category A or B • These shoes cannot be used on rough ground with large obstacles such as boulders or fallen trees • Travel at high speed only on flat ground • Travel slowly at low speed if it is impossible to avoid going over obstacles

8. SPECIFICATIONS FOR MAJOR COMPONENTS

1) ENGINE

Item	Specification
Model	Cummins QSB6.7 / HYUNDAI HE 6.7
Type	4-cycle turbocharged diesel engine, low emission
Cooling method	Water cooling
Number of cylinders and arrangement	6 cylinders, in-line
Firing order	1-5-3-6-2-4
Combustion chamber type	Direct injection type
Cylinder bore × stroke	107 × 124 mm (4.2" × 4.9")
Piston displacement	6700 cc (409cu in)
Compression ratio	17.2 : 1
Rated gross horse power (SAE J1995)	151 Hp at 1900 rpm (113 kW at 1900 rpm)
Maximum torque at 1500 rpm	63.0 kgf · m (456 lbf · ft)
Engine oil quantity	24 l (6.3 U.S. gal)
Dry weight	556 kg (1226 lb)
High idling speed	1950 ± 50 rpm
Low idling speed	850 ± 100 rpm
Rated fuel consumption	167.8 g/Hp · hr at 1900 rpm
Starting motor	Nippon denso (24 V-4.5 kW)
Alternator	Delco Remy (24 V-70 A)
Battery	2 × 12 V × 100 Ah

2) MAIN PUMP

Item	Specification
Type	Variable displacement tandem axis piston pumps
Capacity	2 × 117cc/rev
Maximum pressure	350kgf/cm ² (4980psi) [380 kgf/cm ² (5400 psi)]
Rated oil flow	2 × 222 l /min (58.6U.S. gpm/ 48.8U.K. gpm)
Rated speed	1900 rpm

[] : Power boost

3) GEAR PUMP

Item	Specification
Type	Fixed displacement gear pump single stage
Capacity	15 cc/rev
Maximum pressure	40 kgf/cm ² (570 psi)
Rated oil flow	28.5 l /min (7.5 U.S. gpm/6.3 U.K. gpm)

4) MAIN CONTROL VALVE

Item	Specification	
Type	9 spools two-block	
Operating method	Hydraulic pilot system	
Main relief valve pressure	350 kgf/cm ² (4980 psi) [380 kgf/cm ² (5400 psi)]	
Port relief valve pressure	Boom	400 kgf/cm ² (5690 psi)
	Arm	400 kgf/cm ² (5690 psi)
	Bucket	400 kgf/cm ² (5690 psi)

[]: Power boost

5) SWING MOTOR

Item	Specification
Type	Two fixed displacement axial piston motor
Capacity	151 cc/rev
Relief pressure	285 kgf/cm ² (4050 psi)
Braking system	Automatic, spring applied hydraulic released
Braking torque	59 kgf · m (427 lbf · ft)
Brake release pressure	33~50 kgf/cm ² (470~711 psi)
Reduction gear type	2 - stage planetary

6) TRAVEL MOTOR

Item	Specification
Type	Variable displacement axial piston motor
Relief pressure	350 kgf/cm ² (4980 psi)
Reduction gear type	2-stage planetary
Braking system	Automatic, spring applied hydraulic released
Brake release pressure	11 kgf/cm ² (156 psi)
Braking torque	49.3 kgf · m (357 lbf · ft)

7) CYLINDER

Item		Specification
Boom cylinder	Bore dia × Rod dia × Stroke	∅ 120 × ∅ 85 × 1290 mm
	Cushion	Extend only
Arm cylinder	Bore dia × Rod dia × Stroke	∅ 140 × ∅ 100 × 1510 mm
	Cushion	Extend and retract
Bucket cylinder	Bore dia × Rod dia × Stroke	∅ 120 × ∅ 85 × 1055 mm
	Cushion	Extend only

※ Discoloration of cylinder rod can occur when the friction reduction additive of lubrication oil spreads on the rod surface.

※ Discoloration does not cause any harmful effect on the cylinder performance.

8) SHOE

Item		Width	Ground pressure	Link quantity	Overall width
R235LCR-9	Standard	600 mm (24")	0.51 kgf/cm ² (7.25 psi)	49	2990 mm (9' 10")
	Option	700 mm (28")	0.44 kgf/cm ² (6.26 psi)	49	3090 mm (10' 2")
		800 mm (32")	0.39 kgf/cm ² (5.55 psi)	49	3190 mm (10' 6")
		900 mm (36")	0.35 kgf/cm ² (4.98 psi)	49	3290 mm (10' 10")

9) BUCKET

Item	Capacity		Tooth quantity	Width	
	SAE heaped	CECE heaped		Without side cutter	With side cutter
R235LCR-9	0.51 m ³ (0.67 yd ³)	0.45 m ³ (0.59 yd ³)	3	700 mm (27.6")	820 mm (32.3")
	0.80 m ³ (1.05 yd ³)	0.70 m ³ (0.92 yd ³)	5	1000 mm (39.4")	1120 mm (44.1")
	0.87 m ³ (1.14 yd ³)	0.75 m ³ (0.98 yd ³)	5	1090 mm (42.9")	1120 mm (47.6")
	0.92 m ³ (1.20 yd ³)	0.80 m ³ (1.05 yd ³)	5	1150 mm (45.3")	1270 mm (50.0")
	1.10 m ³ (1.44 yd ³)	0.96 m ³ (1.26 yd ³)	5	1320 mm (52.0")	1440 mm (56.7")
	1.20 m ³ (1.57 yd ³)	1.00 m ³ (1.31 yd ³)	5	1400 mm (55.1")	1520 mm (60.0")
	1.34 m ³ (1.75 yd ³)	1.15 m ³ (1.50 yd ³)	6	1550 mm (61.0")	1670 mm (65.7")
	◆0.74 m ³ (0.97 yd ³)	0.65 m ³ (0.85 yd ³)	5	985 mm (38.8")	-
	◆0.90 m ³ (1.18 yd ³)	0.80 m ³ (1.05 yd ³)	5	1070 mm (42.1")	-
	◆1.05 m ³ (1.37 yd ³)	0.92 m ³ (1.20 yd ³)	5	1290 mm (50.8")	-
	◎0.87 m ³ (1.14 yd ³)	0.75 m ³ (0.98 yd ³)	5	1140 mm (44.9")	-
	■0.75 m ³ (0.98 yd ³)	0.65 m ³ (0.85 yd ³)	-	1790 mm (70.5")	-

◆ : Heavy duty bucket

◎ : Rock bucket

■ : Slope finishing bucket

9. RECOMMENDED OILS

Use only oils listed below. Do not mix different brand oil.

Please use HYUNDAI genuine oil and grease.

Service point	Kind of fluid	Capacity ℓ (U.S. gal)	Ambient temperature °C (°F)						
			-50 (-58)	-30 (-22)	-20 (-4)	-10 (14)	0 (32)	10 (50)	20 (68)
Engine oil pan	Engine oil	24 (6.3)	★SAE 5W-40						
			SAE 30						
			SAE 10W						
			SAE 10W-30						
			SAE 15W-40						
Swing drive	Gear oil	5.0 (1.3) ^{★2} 6.2 (1.7)	★SAE 75W-90						
Final drive		5.8 × 2 (1.5 × 2)	SAE 80W-90						
Hydraulic tank	Hydraulic oil	Tank; 160 (42) System; 275 (73)	★ISO VG 15						
			ISO VG 32						
			ISO VG 46						
			ISO VG 68						
Fuel tank	Diesel fuel	320 (85)	★ASTM D975 NO.1						
			ASTM D975 NO.2						
Fitting (grease nipple)	Grease	As required	★NLGI NO.1						
			NLGI NO.2						
Radiator (reservoir tank)	Mixture of antifreeze and soft water ^{★1}	35 (9.2)	Ethylene glycol base permanent type (50 : 50)						
			★Ethylene glycol base permanent type (60 : 40)						

SAE : Society of Automotive Engineers

API : American Petroleum Institute

ISO : International Organization for Standardization

NLGI : National Lubricating Grease Institute

ASTM : American Society of Testing and Material

★2 : Service when the grease inlet exists on the equipment

★1 : Soft water
City water or distilled water

★ : Cold region
Russia, CIS, Mongolia