

GROUP 2 ENGINE SYSTEM

ENGINE AND ACCESSORIES MOUNTING

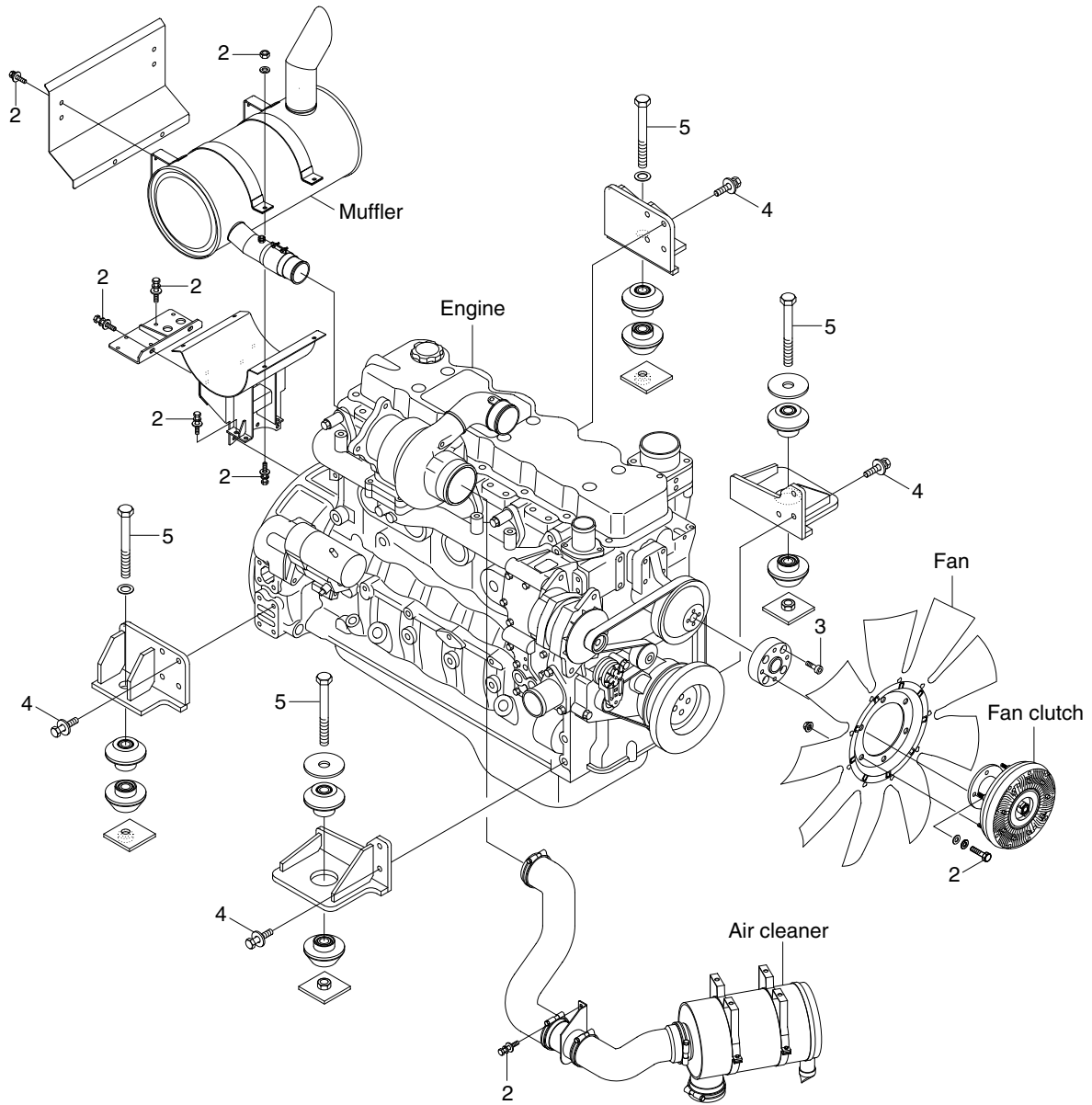

235Z99CM01

• Tightening torque

Item	Size	kgf · m	lbf · ft
1	M 8×1.25	2.5±0.5	18.1±3.6
2	M10×1.5	6.9±1.4	49.9±10.1
3	M10×1.5	8.27±1.7	59.8±12.3

Item	Size	kgf · m	lbf · ft
4	M12×1.75	10.0±1.0	72.3±7.2
5	M20×2.5	55±3.5	398±25.3

COOLING SYSTEM AND FUEL TANK MOUNTING

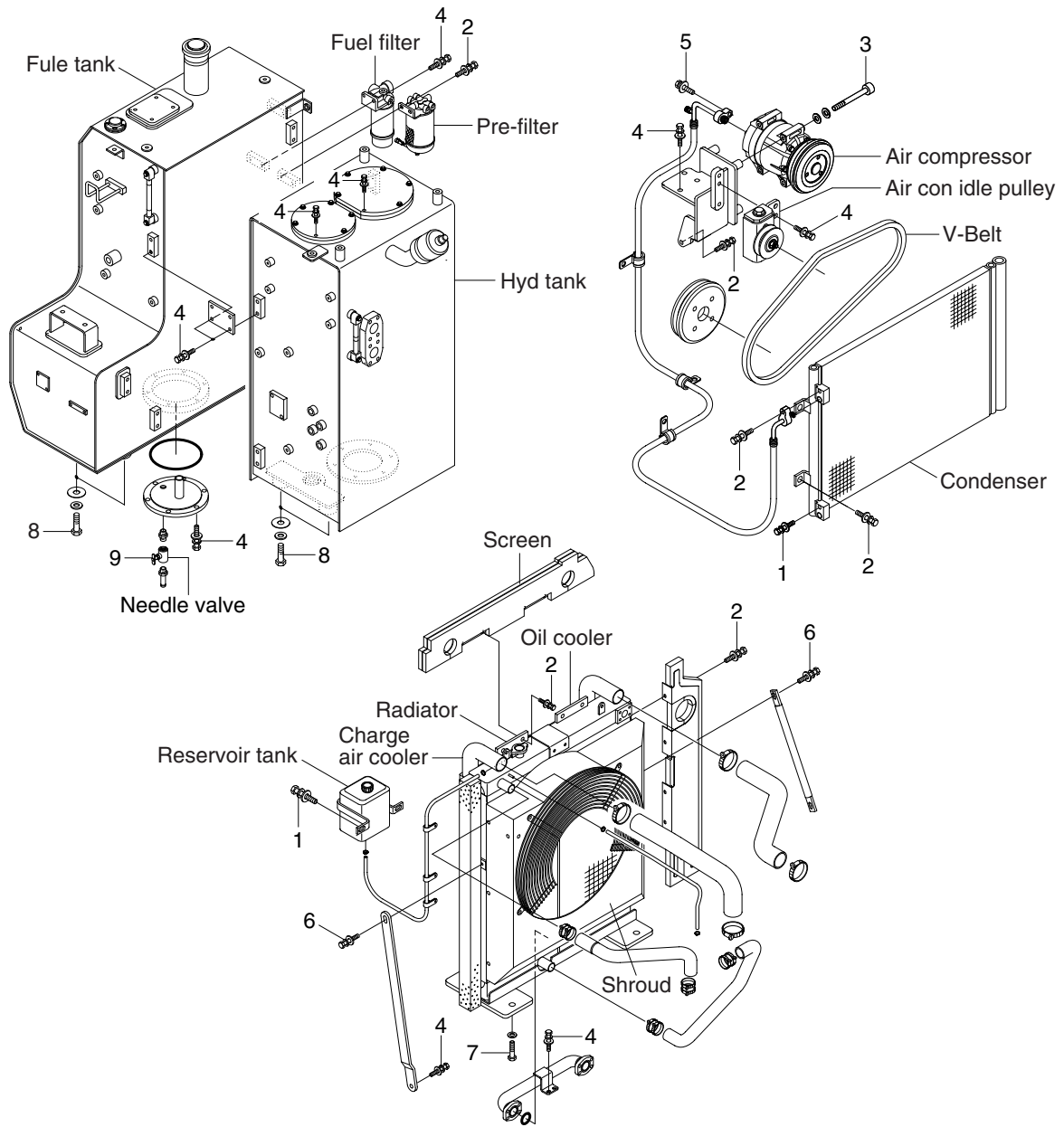

235Z99CM02

· Tightening torque

Item	Size	kgf · m	lbf · ft
1	M 6×1.0	1.05±0.2	7.6±1.45
2	M 8×1.25	2.5±0.5	18.1±3.6
3	M 8×1.25	4.05±0.8	29.3±5.8
4	M10×1.5	6.9±1.4	49.9±10.1
5	M10×1.25	7.4±1.5	53.5±10.8

Item	Size	kgf · m	lbf · ft
6	M12×1.75	12.8±3.0	92.6±21.7
7	M16×2.0	29.7±4.5	215±32.5
8	M20×2.5	46±5.1	333±36.9
9	-	2.3±0.6	16.6±4.3