

SECTION 2 STRUCTURE AND FUNCTION

Group 1 Pump Device	2-1
Group 2 Main Control Valve	2-20
Group 3 Swing Device	2-54
Group 4 Travel Device	2-65
Group 5 RCV Lever	2-79
Group 6 RCV Pedal	2-86

SECTION 2 STRUCTURE AND FUNCTION

GROUP 1 PUMP DEVICE

1. STRUCTURE

The pump device consists of main pump, regulator and gear pump.

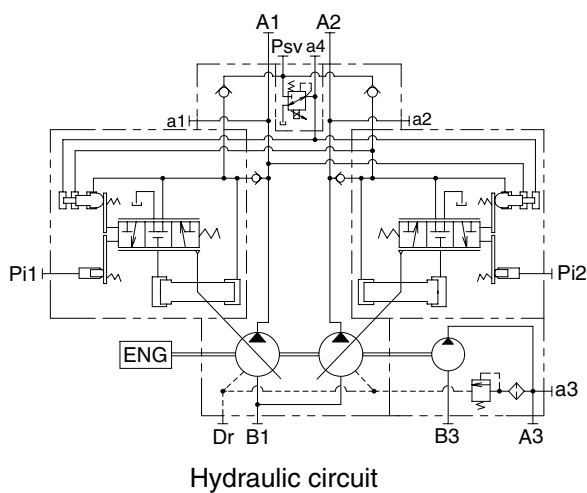
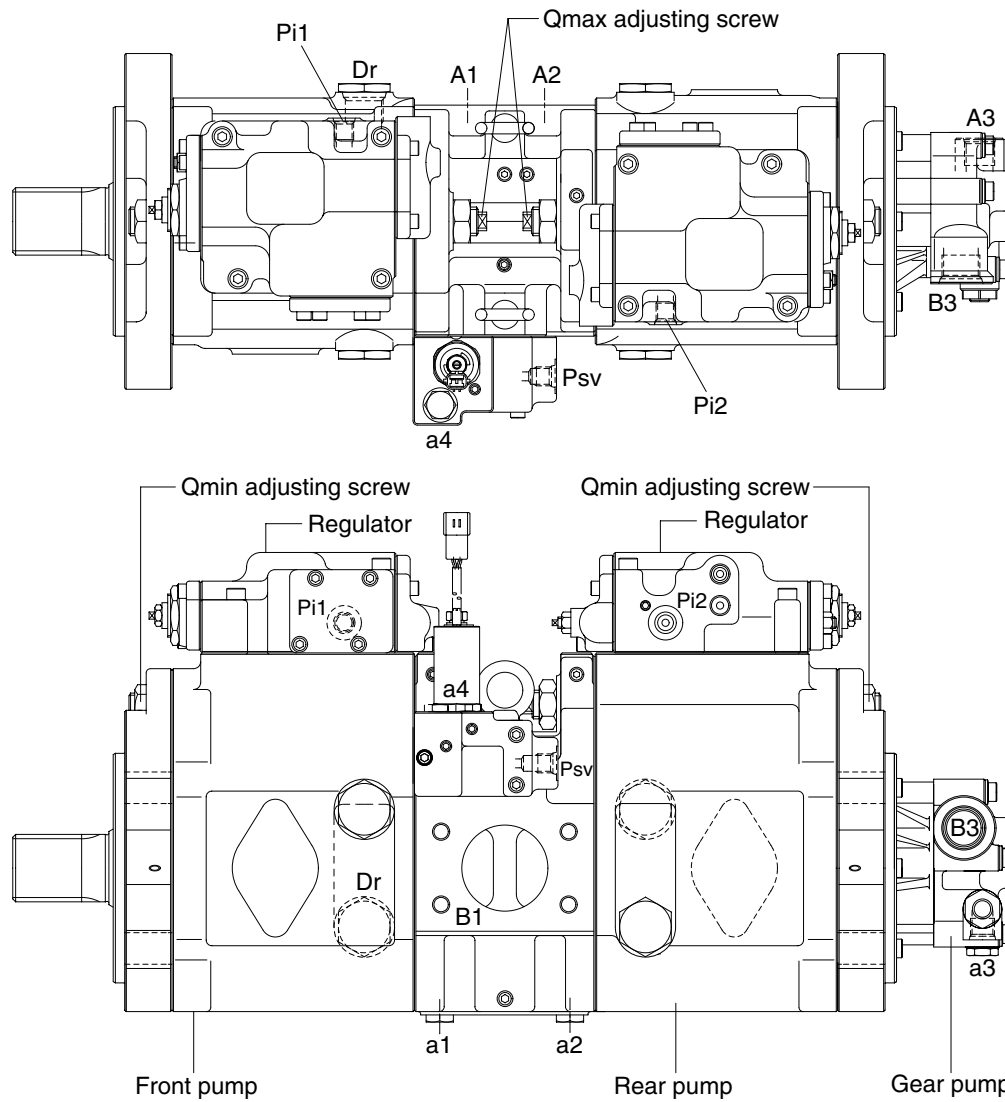

Port	Port name	Port size
A1,2	Delivery port	SAE6000psi 3/4"
B1	Suction port	SAE2500psi 2 1/2"
Dr	Drain port	PF 3/4 - 20
Pi1,i2	Pilot port	PF 1/4 - 15
Psv	Servo assist port	PF 1/4 - 15
a1,2,4	Gauge port	PF 1/4 - 15
a3	Gauge port	PF 1/4-14
A3	Gear pump delivery port	PF 1/2 - 19
B3	Gear pump suction port	PF 3/4 - 20.5

1) MAIN PUMP (1/2)

The main pump consists of two piston pumps (front & rear) and valve block.

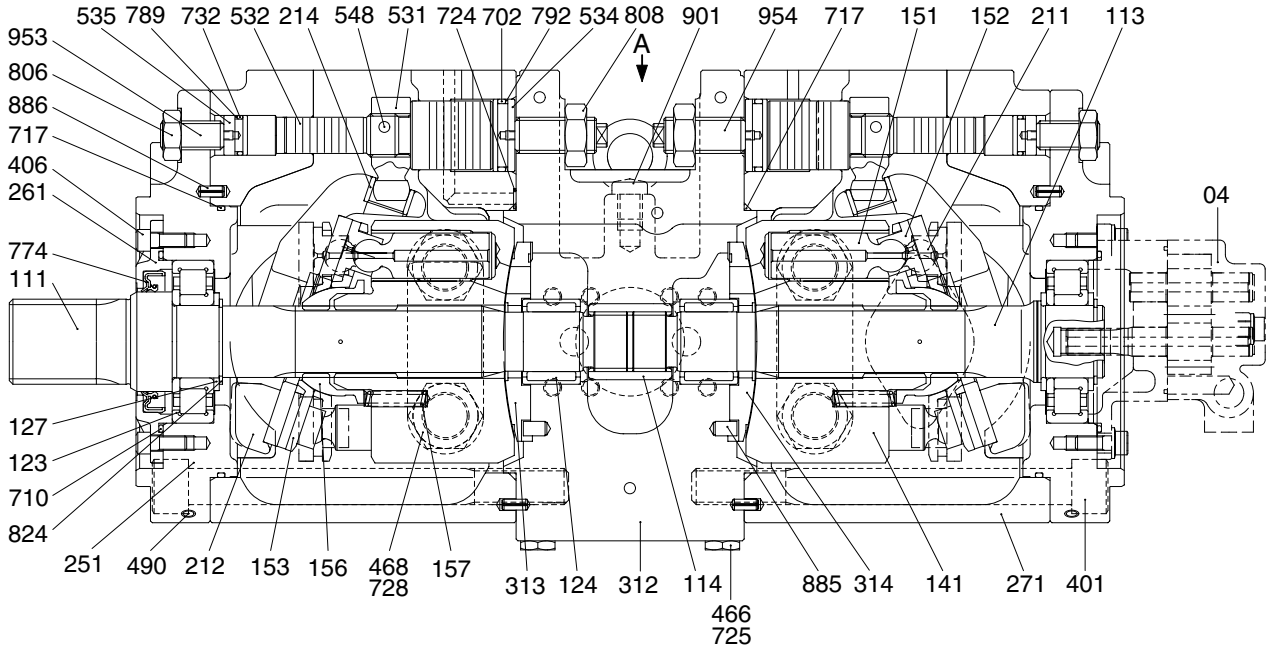

04	Gear pump	261	Seal cover (F)	717	O-ring
111	Drive shaft (F)	271	Pump casing	724	O-ring
113	Drive shaft (R)	312	Valve block	725	O-ring
114	Spline coupling	313	Valve plate (R)	728	O-ring
123	Roller bearing	314	Valve plate (L)	732	O-ring
124	Needle bearing	401	Hexagon socket bolt	774	Oil seal
127	Bearing spacer	406	Hexagon socket bolt	789	Back up ring
141	Cylinder block	466	VP Plug	792	Back up ring
151	Piston	468	VP Plug	806	Hexagon head nut
152	Shoe	490	Plug	808	Hexagon head nut
153	Set plate	531	Tilting pin	824	Snap ring
156	Bushing	532	Servo piston	885	Pin
157	Cylinder spring	534	Stopper (L)	886	Spring pin
211	Shoe plate	535	Stopper (S)	901	Eye bolt
212	Swash plate	548	Pin	953	Set screw
214	Bushing	702	O-ring	954	Set screw
251	Support	710	O-ring		

MAIN PUMP (2/2)

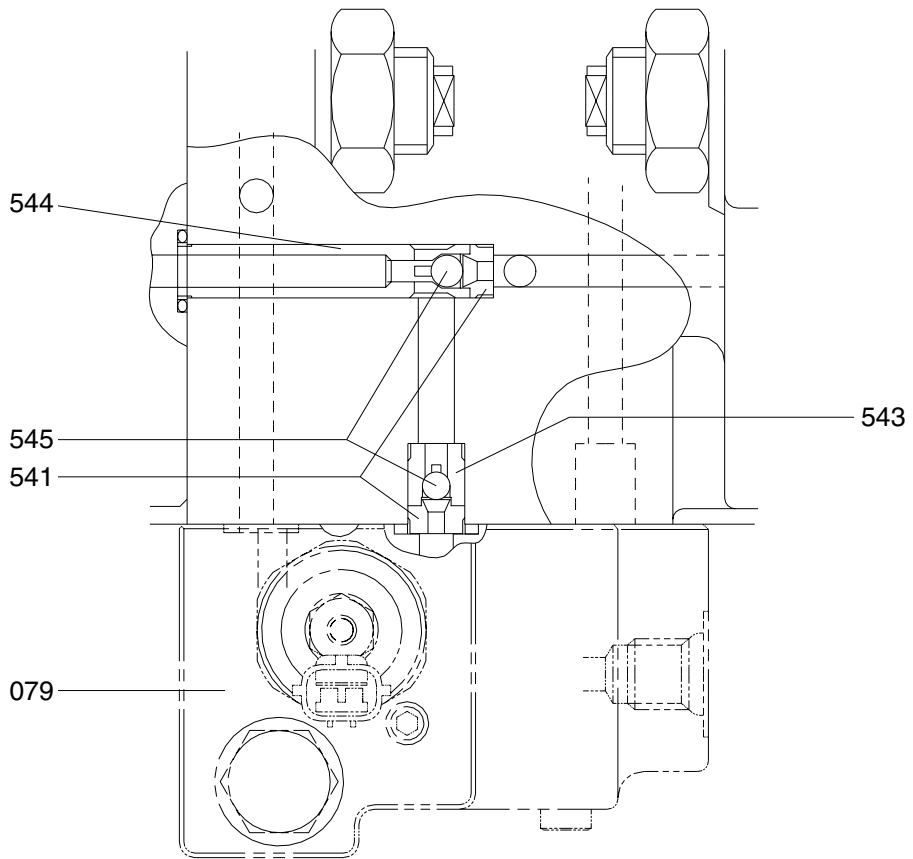

VIEW A

- | | | | | | |
|-----|-----------------------------|-----|-----------|-----|------------|
| 079 | Proportional reducing valve | 543 | Stopper 1 | 545 | Steel ball |
| 541 | Seat | 544 | Stopper 2 | | |

2) REGULATOR (1/2)

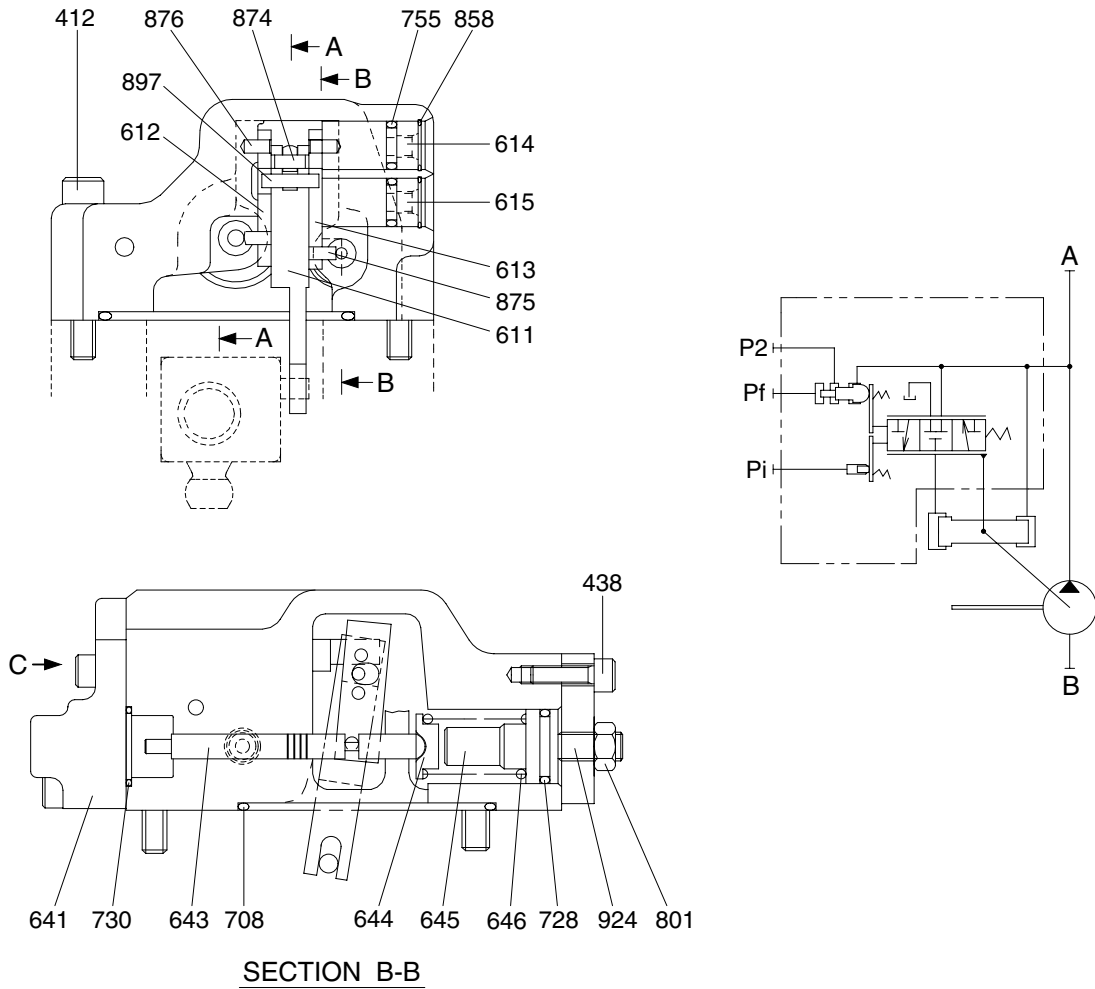

SECTION B-B

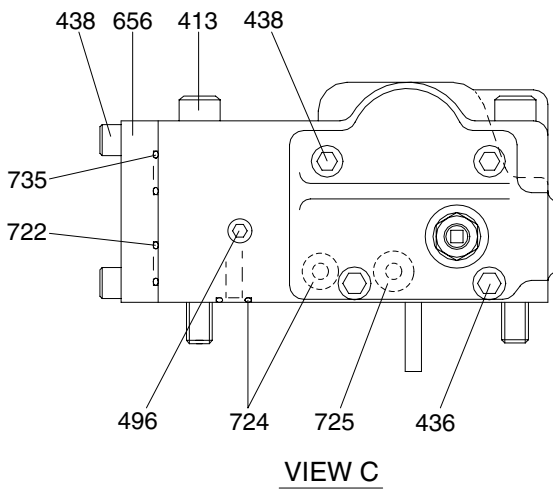

Port	Port name	Port size
A	Delivery port	3/4"
B	Suction port	2 1/2"
Pi	Pilot port	PF 1/4-15
Pf	Power shift port	-
P2	Companion delivery port	-

REGULATOR (2/2)

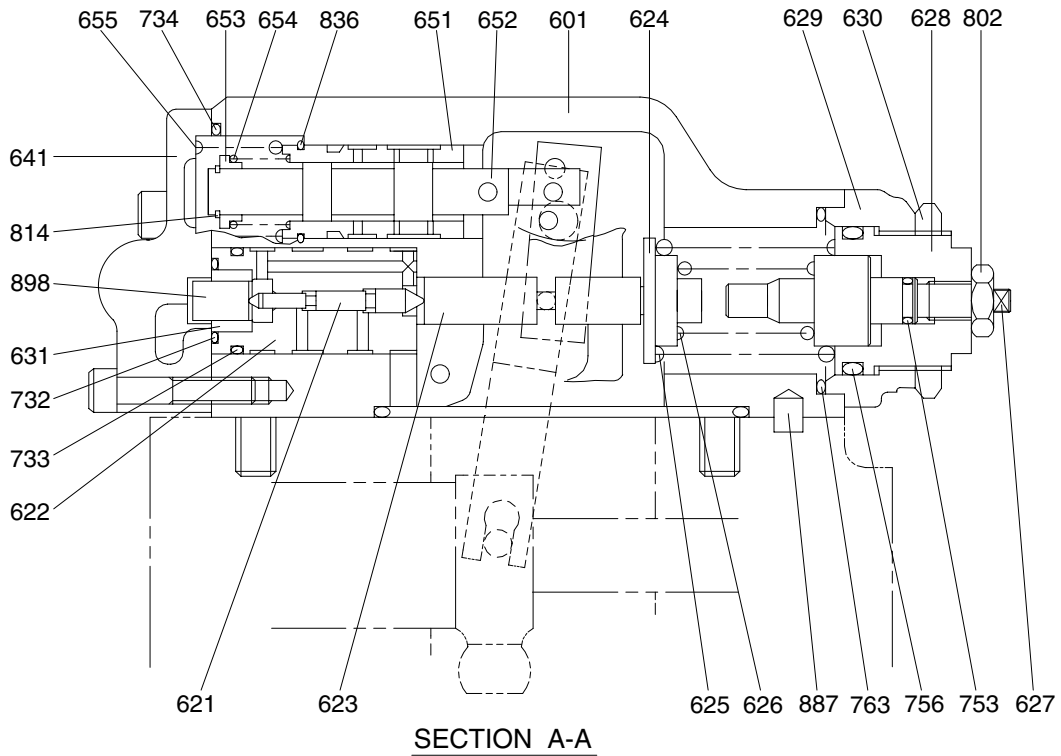

412 Hexagon socket screw	630 Lock nut	733 O-ring
413 Hexagon socket screw	631 Sleeve, pf	734 O-ring
436 Hexagon socket screw	641 Pilot cover	735 O-ring
438 Hexagon socket screw	643 Pilot piston	753 O-ring
496 Plug	644 Spring seat (Q)	755 O-ring
601 Casing	645 Adjust stem (Q)	756 O-ring
611 Feed back lever	646 Pilot spring	763 O-ring
612 Lever (1)	651 Sleeve	801 Nut
613 Lever (2)	652 Spool	802 Nut
614 Fulcrum plug	653 Spring seat	814 Snap ring
615 Adjust plug	654 Return spring	836 Snap ring
621 Compensator piston	655 Set spring	858 Snap ring
622 Piston case	656 Block cover	874 Pin
623 Compensator rod	708 O-ring	875 Pin
624 Spring seat (C)	722 O-ring	876 Pin
625 Outer spring	724 O-ring	887 Pin
626 Inner spring	725 O-ring	897 Pin
627 Adjust stem (C)	728 O-ring	898 Pin
628 Adjust screw (C)	730 O-ring	924 Set screw
629 Cover (C)	732 O-ring	

3) GEAR PUMP

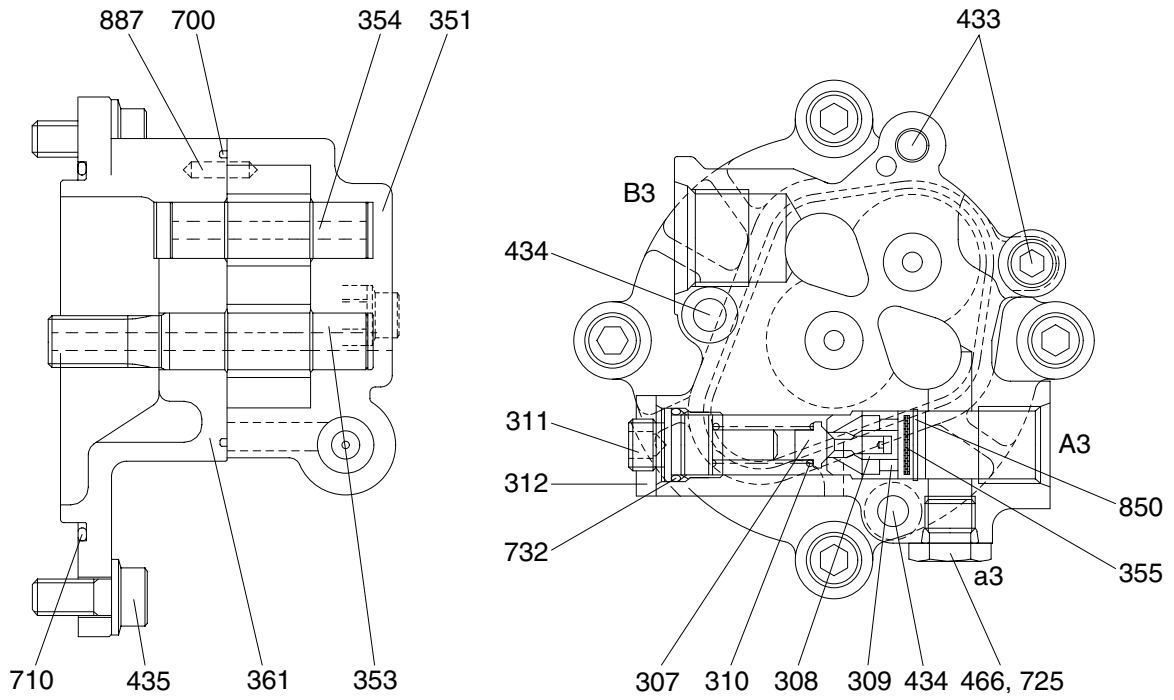

- 307 Poppet
- 308 Seat
- 309 Spring seat
- 310 Spring
- 311 Screw
- 312 Nut
- 351 Gear case

- 353 Drive gear
- 354 Driven gear
- 355 Filter
- 361 Front case
- 433 Flange socket
- 434 Flange socket
- 435 Flange socket

- 466 Plug
- 700 Ring
- 710 O-ring
- 725 O-ring
- 732 O-ring
- 850 Snap ring
- 887 Pin

2. FUNCTION

1) MAIN PUMP

The pumps may be classified roughly into the rotary group performing a rotary motion and working as the major part of the whole pump function: the swash plate group that varies the delivery rates: and the valve cover group that changes over oil suction and discharge.

(1) Rotary group

The rotary group consists of drive shaft (F) (111), cylinder block (141), piston shoes (151,152), set plate (153), spherical bushing (156) and cylinder spring (157). The drive shaft is supported by bearing (123,124) at its both ends.

The shoe is caulked to the piston to form a spherical coupling. It has a pocket to relieve thrust force generated by loading pressure and to take hydraulic balance so that it slides lightly over the shoe plate (211). The sub group composed by a piston and a shoe is pressed against the shoe plate by the action of the cylinder spring via a retainer and a spherical bush. Similarly, the cylinder block is pressed against valve plate (313) by the action of the cylinder spring.

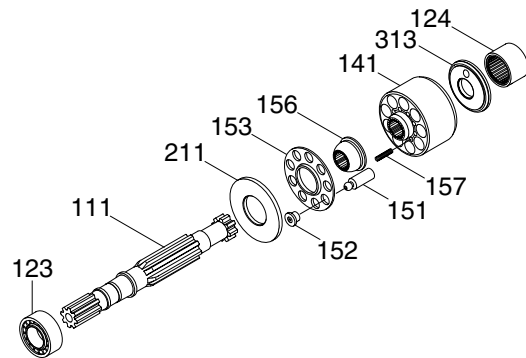

(2) Swash plate group

The swash plate group consists of swash plate (212), shoe plate (211), swash plate support (251), tilting bush (214), tilting pin (531) and servo piston (532).

The swash plate is a cylindrical part formed on the opposite side of the sliding surface of the shoe and is supported by the swash support.

If the servo piston moves to the right and left as hydraulic force controlled by the regulator is admitted to hydraulic chamber located on both sides of the servo piston, the swash plate slides over the swash plate support via the spherical part of the tilting pin to change the tilting angle (α).

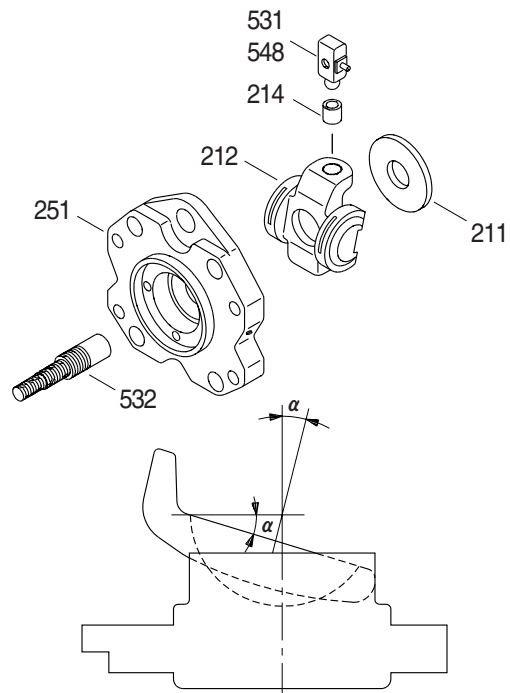

(3) Valve block group

The valve block group consists of valve block (312), valve plate (313) and valve pin(885).

The valve plate having two melon-shaped ports is fixed to the valve block and feeds and collects oil to and from the cylinder block.

The oil changed over by the valve plate is connected to an external pipeline by way of the valve block.

Now, if the drive shaft is driven by a prime mover (electric motor, engine, etc), it rotates the cylinder block via a spline linkage at the same time. If the swash plate is tilted as in Fig (previous page) the pistons arranged in the cylinder block make a reciprocating motion with respect to the cylinder block, while they revolve with the cylinder block.

If you pay attention to a single piston, it performs a motion away from the valve plate (oil sucking process) within 180 degrees, and makes a motion towards the valve plate (or oil discharging process) in the rest of 180 degrees. When the swash plate has a tilting angle of zero, the piston makes no stroke and discharges no oil.

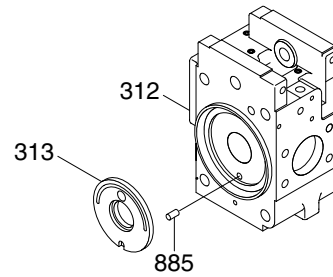

2) REGULATOR

Regulator consists of the negative flow control, total horse power control and power shift control function.

(1) Negative flow control

By changing the pilot pressure P_i , the pump tilting angle (delivery flow) is regulated arbitrarily, as shown in the figure.

This regulator is of the negative flow control in which the delivery flow Q decreases as the pilot pressure P_i rises.

With this mechanism, when the pilot pressure corresponding to the flow required for the work is commanded, the pump discharges the required flow only, and so it does not consume the power uselessly.

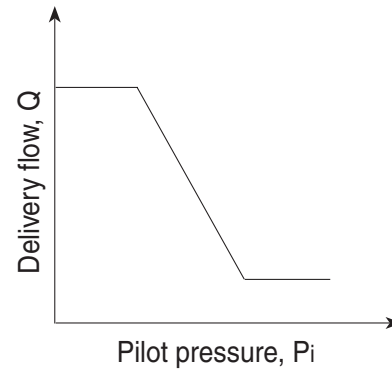

① Flow reducing function

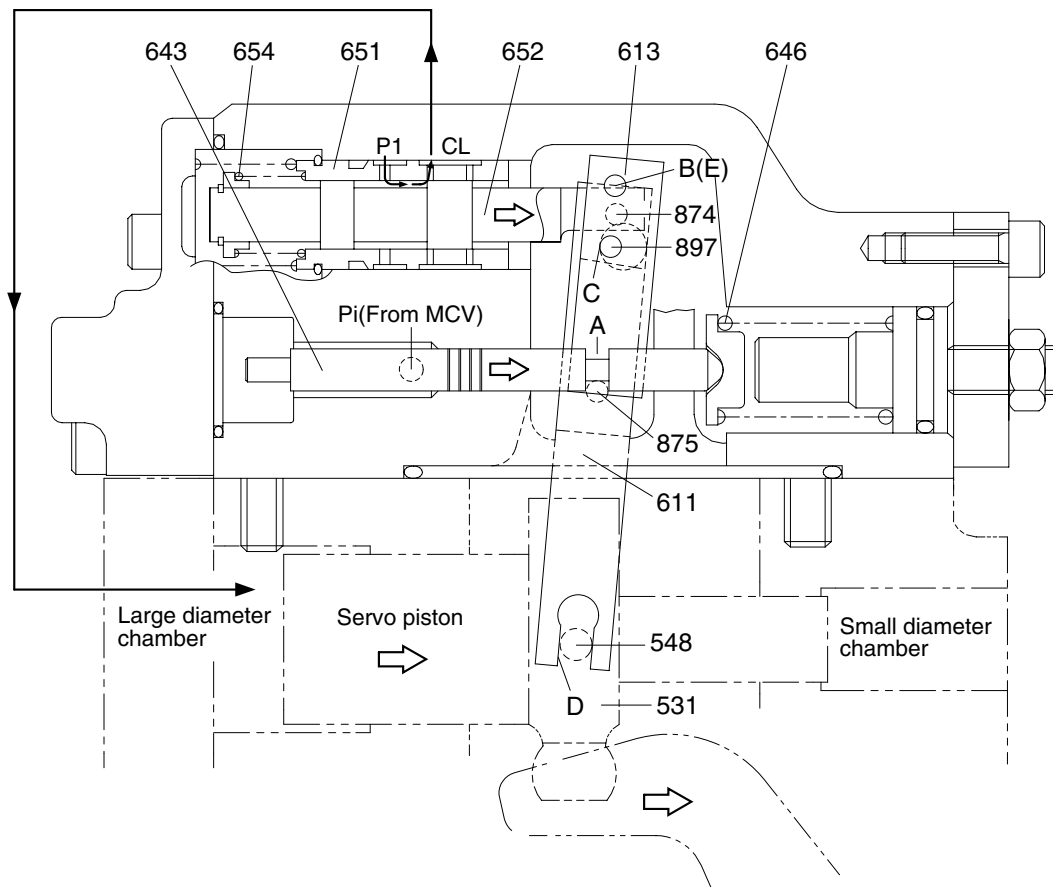

As the pilot pressure P_i rises, the pilot piston (643) moves to the right to a position where the force of the pilot spring (646) balances with the hydraulic force.

The groove (A) in the pilot piston is fitted with the pin (875) that is fixed to lever 2 (613). Therefore, when the pilot piston moves, lever 2 rotates around the fulcrum of point B [fixed by the fulcrum plug (614) and pin (875)]. Since the large hole section (C) of lever 2 contains a protruding pin (897) fixed to the feedback lever (611), the pin (897) moves to the right as lever 2 rotates. Since the opposing-flat section (D) of the feedback lever is fitted with the pin (548) fixed by the tilting pin (531) that swings the swash plate, the feedback lever rotates around the fulcrum of point D, as the pin (897) moves.

Since the feedback lever is connected with the spool (652) via the pin (874), the spool moves to the right.

The movement of the spool causes the delivery pressure P_1 to connect to port CL through the spool and to be admitted to the large diameter section of the servo piston. The delivery pressure P_1 that is constantly admitted to the small diameter section of the servo piston moves the servo piston to the right due to the area difference, resulting in decrease of the tilting angle.

When the servo piston moves to the right, point D also moves to the right. The spool is fitted with the return spring (654) and is tensioned to the left at all times, and so the pin (897) is pressed against the large hole section (C) of lever 2.

Therefore, as point D moves, the feedback lever rotates around the fulcrum of point C, and the spool is shifted to the left. This causes the opening between the sleeve (651) and spool (652) to close slowly, and the servo piston comes to a complete stop when it closes completely.

② Flow increasing function

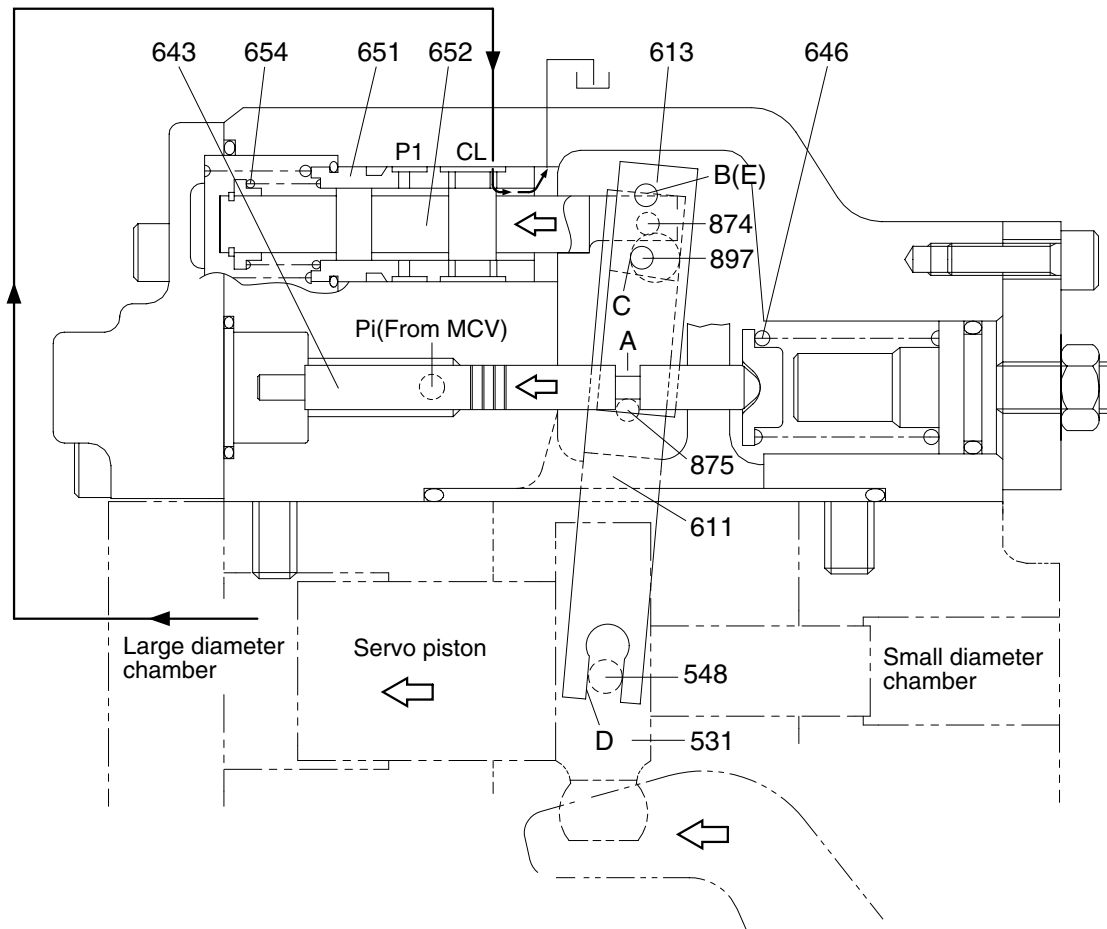

As the pilot pressure P_i decreases, the pilot piston (643) moves to the left by the action of the pilot spring (646) and causes lever 2 (613) to rotate around the fulcrum of point B. Since the pin (897) is pressed against the large hole section (C) of lever 2 by the action of the return spring (654) via the spool (652), pin (874), and feedback lever (611), the feedback lever rotates around the fulcrum of point D as lever 2 rotates, and shifts the spool to the left. Port CL opens a way to the tank port as the spool moves. This deprives the large diameter section of the servo piston of pressure, and shifts the servo piston to the left by the discharge pressure P1 in the small diameter section, resulting in an increase in the flow rate.

As the servo piston moves, point D also moves to the left, the feedback lever rotates around the fulcrum of point C, and the spool moves to the right till the opening between the spool and sleeve is closed.

③ Adjustment of flow control characteristic

The flow control characteristic can be adjusted with the adjusting screw.

Adjust it by loosening the hexagon nut (801) and by tightening (or loosening) the hexagonal socket head screw (924).

Tightening the screw shifts the control chart to the right as shown in the figure.

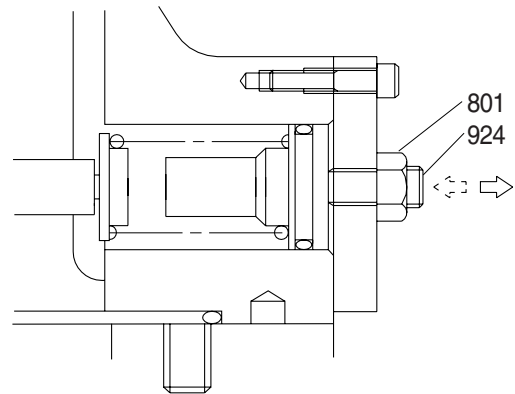

※ Adjusting value

Speed (min^{-1})	Adjustment of flow control characteristic		
	Tightening amount of adjusting screw(924) (Turn)	Flow control starting pressure change amount (kgf/cm^2)	Flow change amount (l/min)
1900	+1/4	+1.5	+14.8

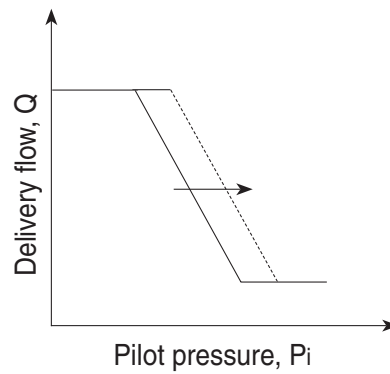

(2) Total horsepower control

The regulator decreases the pump tilting angle (delivery flow) automatically to limit the input torque within a certain value with a rise in the delivery pressure P_1 of the self pump and the delivery pressure P_2 of the companion pump.

(The input horsepower is constant when the speed is constant.)

Since the regulator is of the simultaneous total horsepower type that operates by the sum of load pressures of the two pumps in the tandem double-pump system, the prime mover is automatically prevented from being overloaded, irrespective of the load condition of the two pumps, when horsepower control is under way.

Since this regulator is of the simultaneous total horsepower type, it controls the tilting angles (displacement volumes) of the two pumps to the same value as represented by the following equation :

$$\begin{aligned} T_{in} &= P_1 \times q/2\pi + P_2 \times q/2\pi \\ &= (P_1+P_2) \times q/2\pi \end{aligned}$$

The horsepower control function is the same as the flow control function and is summarized in the following. (For detailed behaviors of respective parts, refer to the section of flow control).

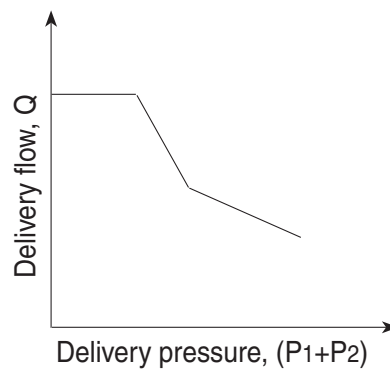

① Overload preventive function

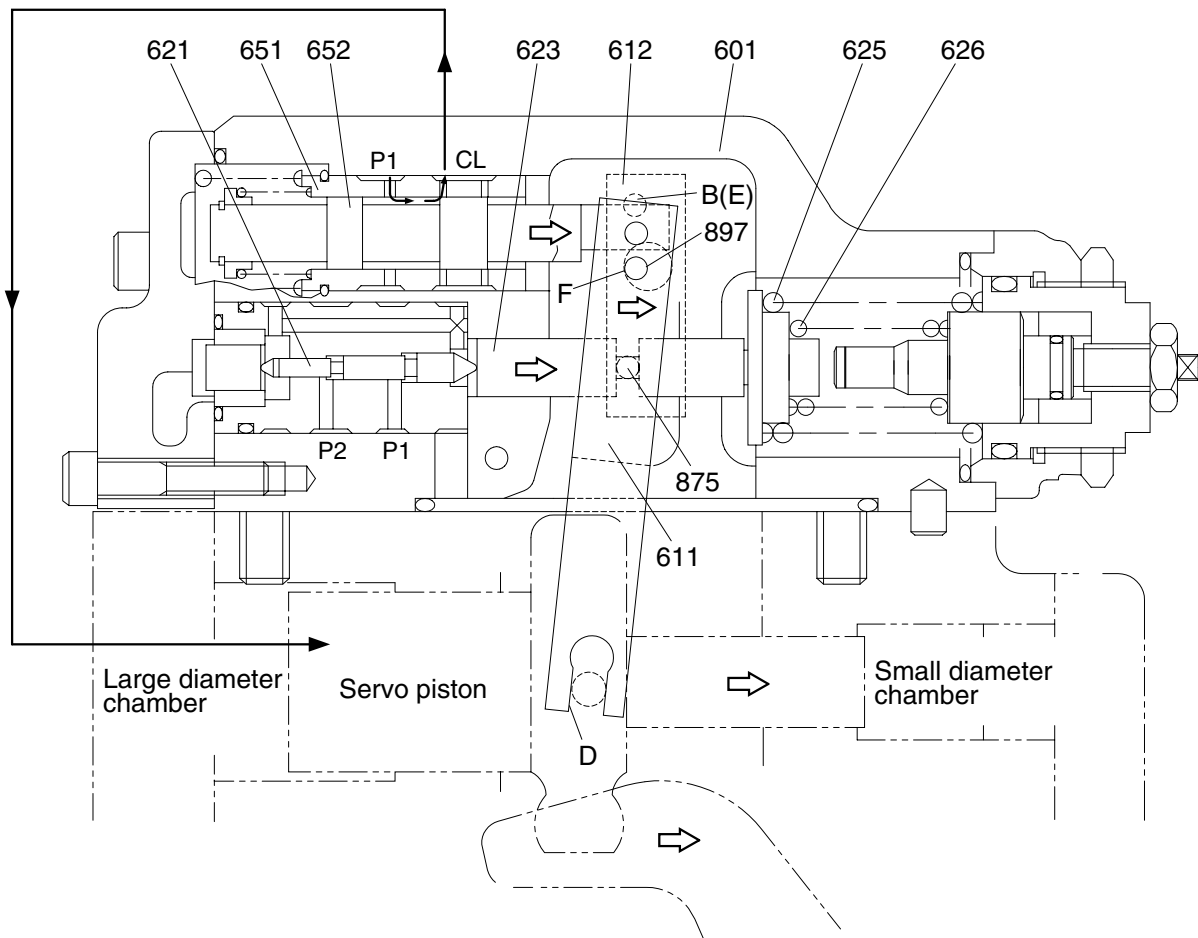

When the self pump delivery pressure P1 or the companion pump delivery pressure P2 rises, it acts on the stepped part of the compensating piston (621). It presses the compensating rod (623) to the right till the force of the outer spring (625) and inner spring (626) balances with the hydraulic force. The movement of the compensating rod is transmitted to lever 1 (612) via pin (875).

Lever 1 rotates around the pin (875) (E) fixed to the casing (601).

Since the large hole section (F) of lever 1 contains a protruding pin (897) fixed to the feedback lever (611), the feedback lever rotates around the fulcrum of point D as lever 1 rotates, and then the spool (652) is shifted to the right. As the spool moves, the delivery pressure P1 is admitted to the large diameter section of the servo piston via port CL, causes the servo piston move to the right, reduces the pump delivery, flow rate, and prevents the prime mover from being overloaded. The movement of the servo piston is transmitted to the feedback lever via point D. Then the feedback lever rotates around the fulcrum of point F and the spool is shifted to the left. The spool moves till the opening between the spool (652) and sleeve (651) is closed.

② Flow reset function

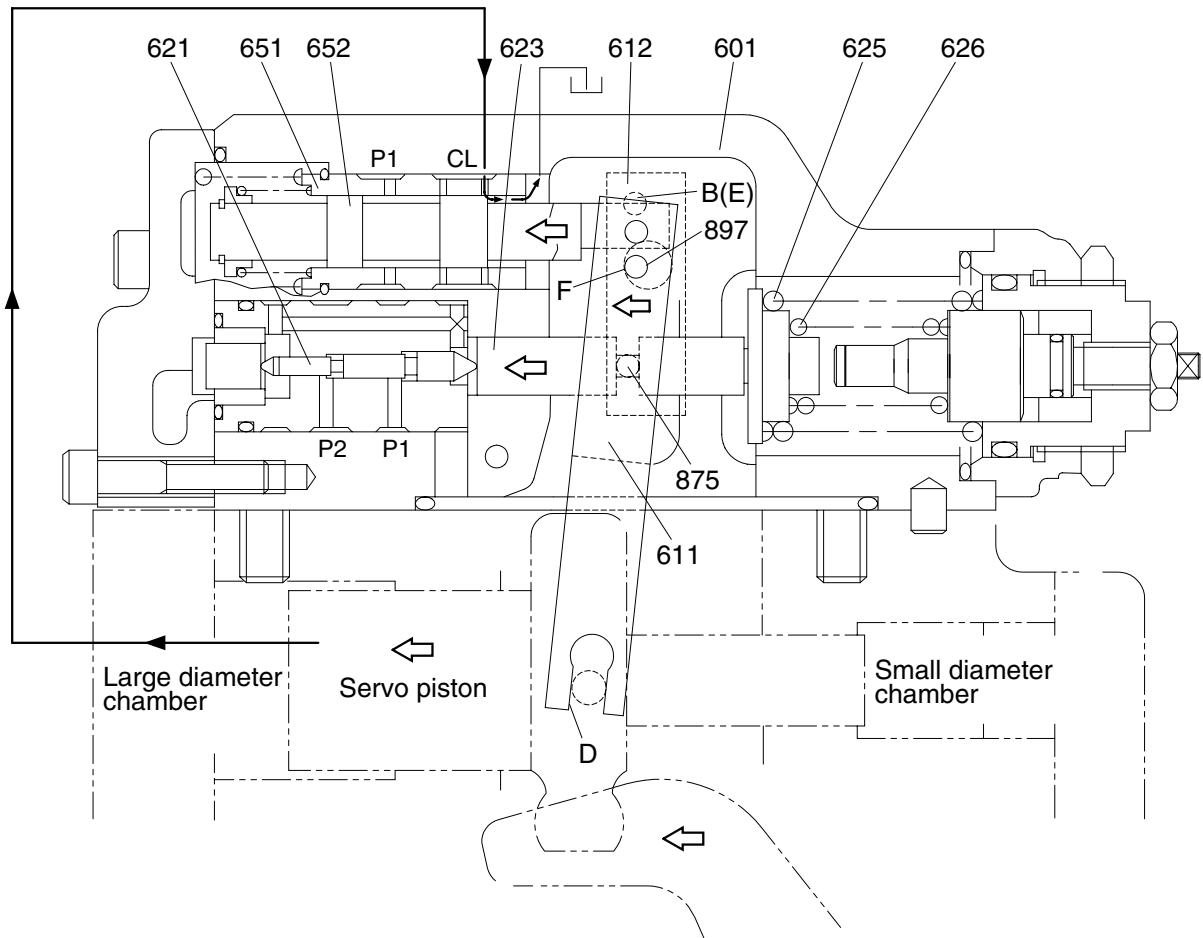

As the self pump delivery pressure P1 or the companion pump delivery pressure P2 decreases, the compensating rod (623) is pushed back by the action of the springs (625 & 626) to rotate lever 1 (612) around point E. Rotating of lever 1 causes the feedback lever (611) to rotate around the fulcrum of point D and then the spool (652) to move to the left. As a result, port CL opens a way to the tank port.

This causes the servo piston to move to the left and the pump's delivery rate to increase.

The movement of the servo piston is transmitted to the spool by the action of the feedback mechanism to move it till the opening between the spool and sleeve is closed.

③ **Low tilting angle (low flow) command preferential function**

As mentioned above, flow control and horsepower control tilting angle commands are transmitted to the feedback lever and spool via the large-hole sections (C & F) of levers 1 and 2. However, since sections C and F have the pins ($\varnothing 4$) protruding from the large hole ($\varnothing 8$), only the lever lessening the tilting angle contacts the pin (897); the hole ($\varnothing 8$) in the lever of a larger tilting angle command is freed without contacting the pin (897). Such a mechanical selection method permits preference of the lower tilting angle command of the flow control and horsepower control.

④ **Adjustment of input horsepower**

a. **Adjustment of outer spring**

Adjust it by loosening the hexagon nut (630) and by tightening (or loosening) the adjusting screw C (628). Tightening the screw shifts the control chart to the right and increases the input horsepower as shown in the figure. Since turning the adjusting screw C by N turns changes the setting of the inner spring (626), return the adjusting stem C (627) by $N \times A$ turns at first. ($A=1.78$)

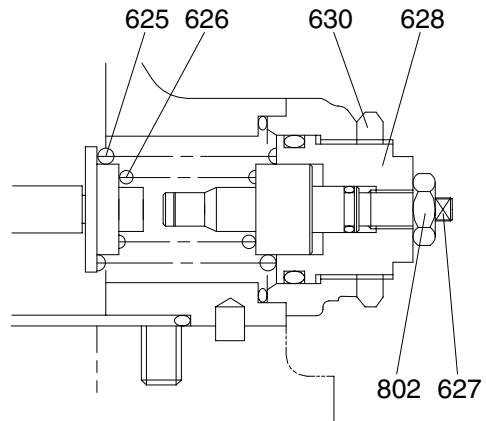

※ **Adjusting value**

Speed	Adjustment of input horsepower		
	Tightening amount of adjusting screw(628)	Compensating control starting pressure change amount	Input torque change amount
(min ⁻¹)	(Turn)	(kgf/cm ²)	(kgf · m)
1900	+1/4	+16.5	+4.0

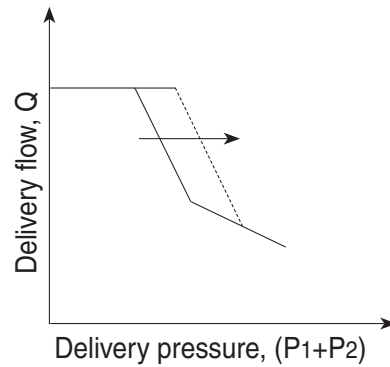

b. Adjustment of inner spring

Adjust it by loosening the hexagon nut (802) and by tightening (or loosening) the adjusting stem C (627).

Tightening the screw increases the flow and then the input horsepower as shown in the figure.

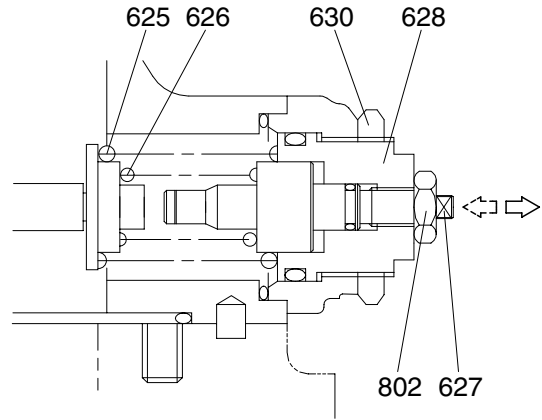

※ Adjusting valve

Speed	Adjustment of input horsepower		
	Tightening amount of adjusting stem (C) (627)	Flow change amount	Input torque change amount
(min ⁻¹)	(Turn)	(l /min)	(kgf·m)
1900	+1/4	+11.3	+4.7

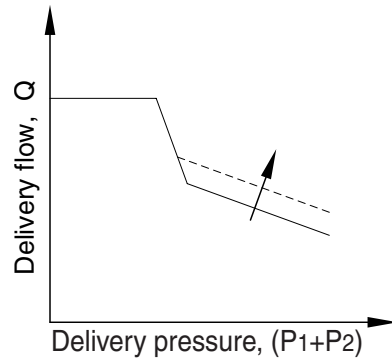

(3) Variable horsepower control

Variable horsepower control can be obtained by supplying pilot pressure.

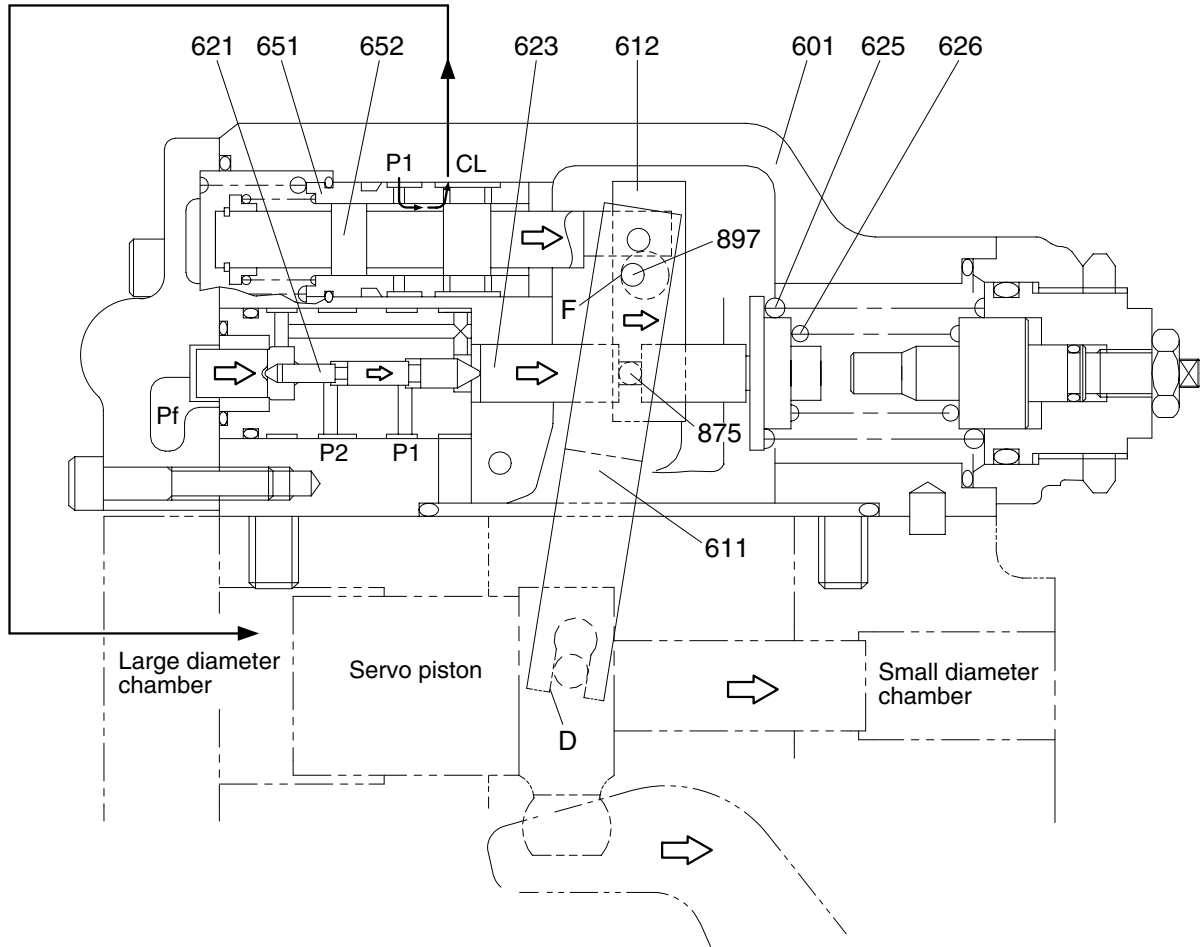

The set horsepower valve is shifted by varying the command current level of the proportional pressure reducing valve attached to the pump. Only one proportional pressure reducing valve is provided.

However, the secondary pressure P_f (power shift pressure) is admitted to the horsepower control section of each pump regulator through the pump's internal path to shift it to the same set horsepower level.

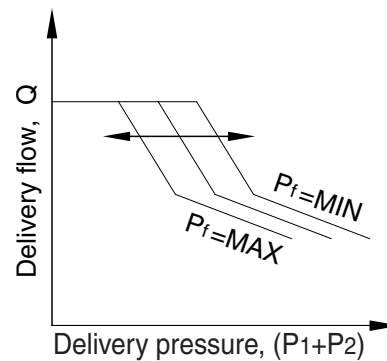

This function permits arbitrary setting of the pump output power, thereby providing the optimum power level according to the operating condition.

The power shift pressure P_f controls the set horsepower of the pump to a desired level, as shown in the figure.

As the power shift pressure P_f rises, the compensating rod (623) moves to the right via the pin (898) and compensating piston (621).

This decreases the pump tilting angle and then the set horsepower in the same way as explained in the overload preventive function of the horsepower control. On the contrary, the set horsepower rises as the power shift pressure P_f falls.

(4) Adjustment of maximum and minimum flows

The regulator can adjust the maximum and minimum flows with the adjusting screws.

① Adjustment of maximum flow

Adjust it by loosening the hexagon nut (808) and by tightening (or loosening) the set screw (954).

The maximum flow only is adjusted without changing other control characteristics.

Speed	Adjustment of max flow	
	Tightening amount of adjusting screw (954)	Flow change amount
(min ⁻¹)	(Turn)	(l /min)
1900	+1/4	-5.5

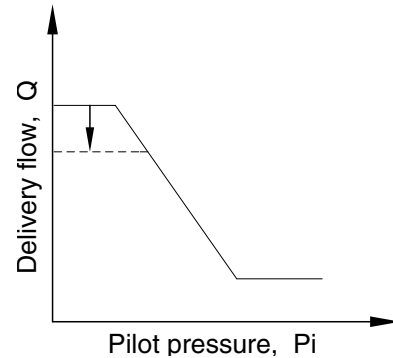
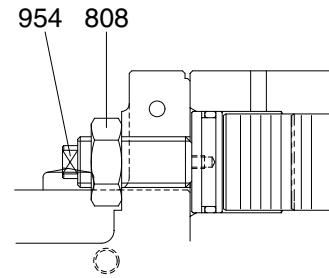

② Adjustment of minimum flow

Adjust it by loosening the hexagon nut (806) and by tightening (or loosening) the hexagonal socket head set screw (953). Similarly to the adjustment of the maximum flow, other characteristics are not changed.

However, remember that, if tightened too much, the required horsepower during the maximum delivery pressure (or during relieving) may increase.

Speed	Adjustment of min flow	
	Tightening amount of adjusting screw (953)	Flow change amount
(min ⁻¹)	(Turn)	(l /min)
1900	+1/4	+4.4

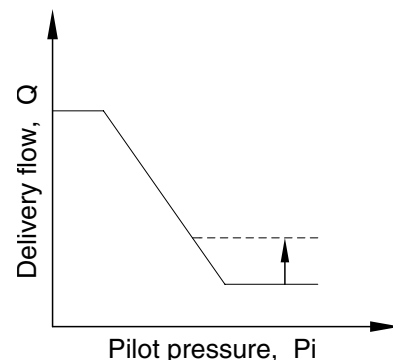
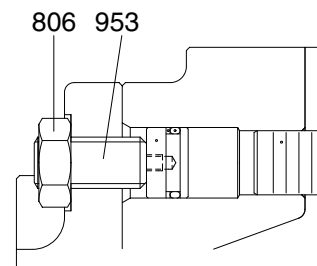

GROUP 2 MAIN CONTROL VALVE

1. STRUCTURE

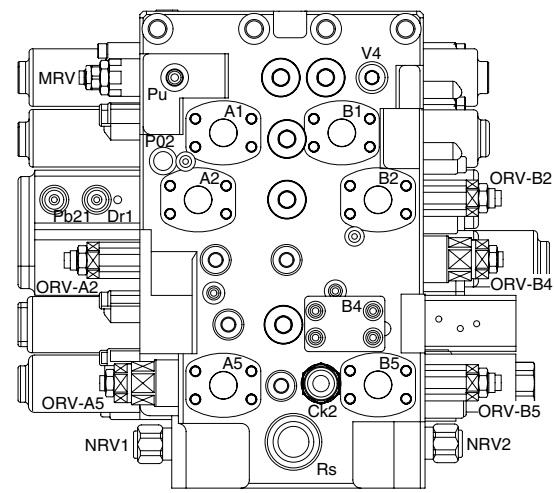

VIEW A

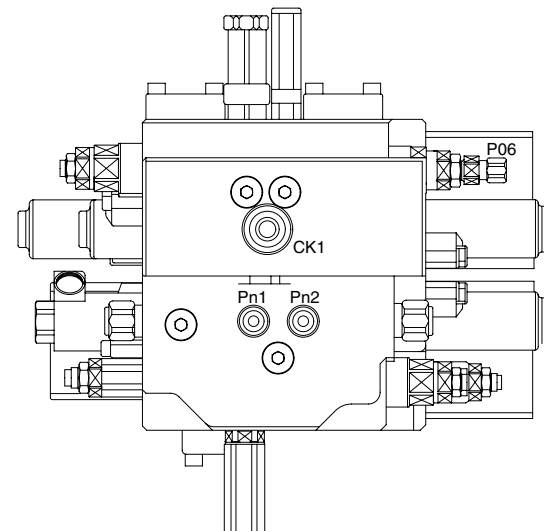
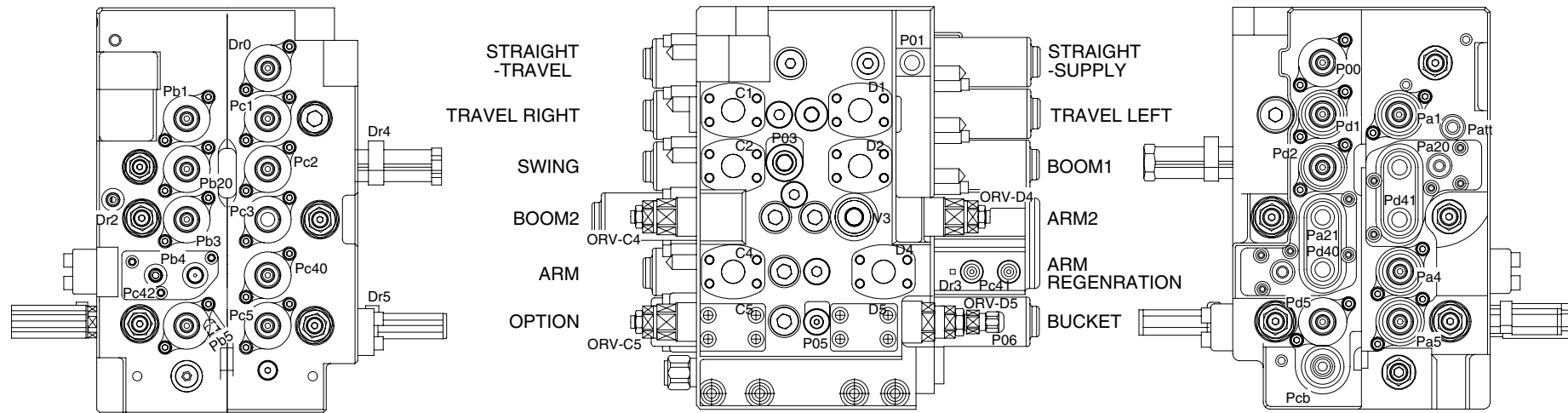
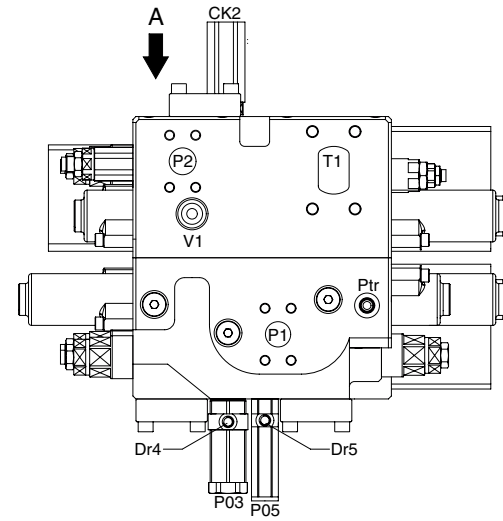

Mark	Port name	Port size	Tightening torque
R _s V ₃	Make up for swing motor Carry-over P port	PF1	20~25 kgf · m (145~180 lbf · ft)
P _{att} P _{b21} P _{cb} P ₀₁ P ₀₂ P ₀₃ P ₀₄ P ₀₅ P ₀₆ P _{c41} P _{c42} P _{tr} P _u D _{r1} D _{r2} D _{r3}	Auto idle signal-attachment Lock valve pilot port (boom) Bucket in confluence pilot port Pilot signal port Pilot signal port Swing logic pilot port Bucket parallel orifice pilot port Option B confluence pilot port Option B 2 stage relief valve pilot port Lock valve pilot port (arm) Arm in regen-cut signal selector port Auto idle signal-travel Power boost Drain port Drain port Drain port	PF1/4	3.5~3.9 kgf · m (25.3~28.2 lbf · ft)
C _{k1} C _{k2}	Bucket confluence Bucket confluence	PF3/4	17~19 kgf · m (123~137.4 lbf · ft)
P _{a1} P _{b1} P _{c1} P _{d1} P _{a20} P _{a21} P _{b20} P _{c2} P _{d2} P _{b3} P _{c3} P _{a4} P _{b4} P _{c4} P _{d40} P _{d41} P _{a5} P _{b5} P _{c5} P _{d5} D _{r0} P _{n1} P _{n2} V ₁ V ₄	Travel pilot port-LH (FW) Travel pilot port-LH (BW) Travel pilot port-RH (BW) Travel pilot port-RH (FW) Boom up pilot port Boom up confluence pilot port Boom down pilot port Swing pilot port (LH) Swing pilot port (RH) Arm in confluence pilot port Swing priority pilot port Option A pilot port (breaker) Arm in regeneration cut port Arm in pilot port Arm out pilot port Arm out confluence pilot port Bucket in pilot port Bucket out pilot port Option B pilot port Option B pilot port Drain port Negative control signal port (A2 port side) Negative control signal port (A1 port side) Carry-over port Carry-over port	PF3/8	7~8 kgf · m (50.6~57.8 lbf · ft)
A ₁ B ₁ C ₁ D ₁ A ₂ B ₂ C ₂ D ₂ B ₄ C ₄ D ₄ A ₅ B ₅ C ₅ D ₅ P ₁ P ₂	Travel motor port-LH (FW) Travel motor port-LH (BW) Travel motor port-RH (BW) Travel motor port-RH (FW) Boom up port Boom down port Swing motor port (LH) Swing motor port (RH) Option A port (breaker) Arm in port Arm out port Bucket in port Bucket out port Option B port Option B port Pump port (A2 side) Pump port (A1 side)	SAE 5000 psi 1"	7.5~9.2 kgf · m (54.2~66.5 lbf · ft)
D _{r4} D _{r5}	Drain port Drain port	PF1/8	1.5~1.9 kgf · m (10.8~13.7 lbf · ft)
T ₁	Return port	SAE 3000 psi 2" (M12)	6.4~8.6 kgf · m (46.2~62.2 lbf · ft)

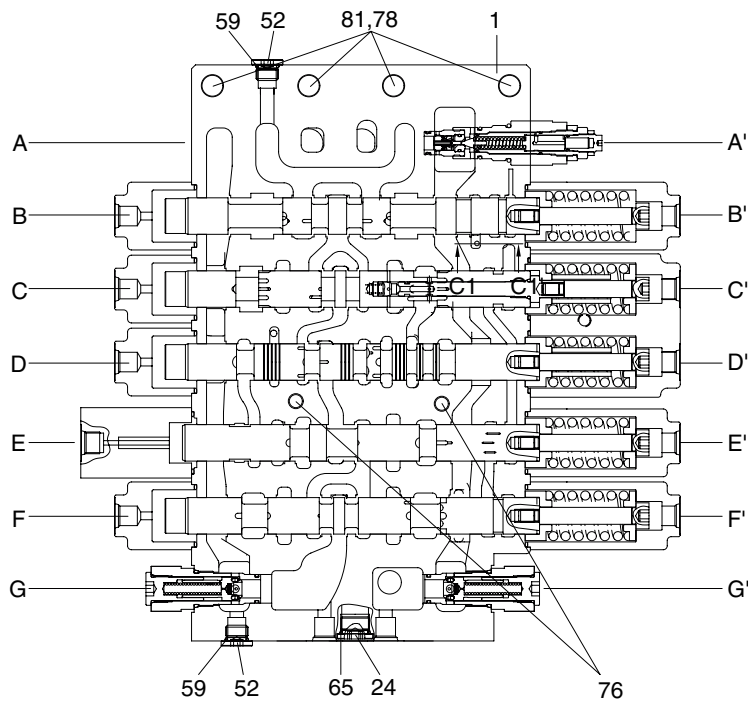

P1 BLOCK SPOOL SECTION

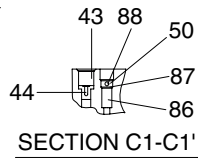

SECTION C1-C1'

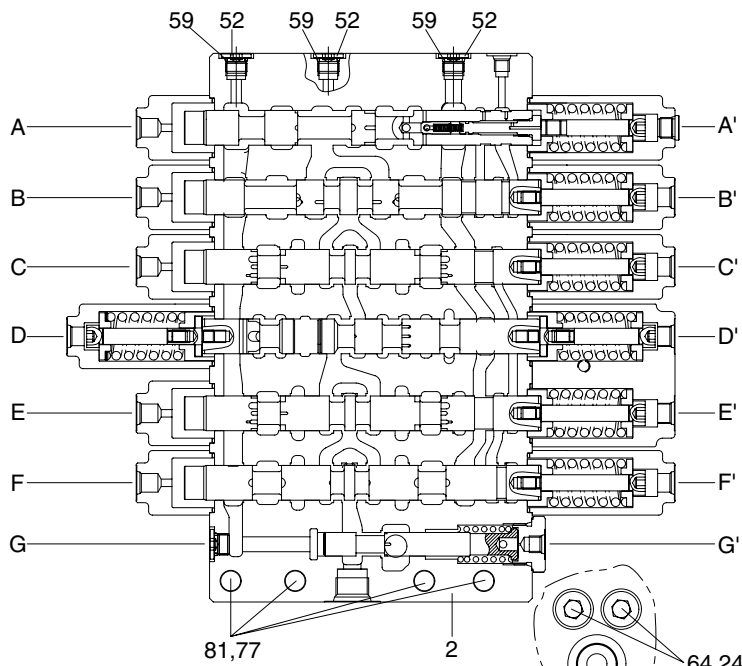

P2 BLOCK SPOOL SECTION

- 1 Housing (P1)
- 2 Housing (P2)
- 24 Plug
- 43 Orifice-signal
- 44 Coin type filter
- 50 O-ring
- 52 Plug
- 59 O-ring
- 64 O-ring
- 65 O-ring
- 76 Socket bolt
- 77 Hex socket head bolt
- 78 Hex socket head bolt
- 81 Spring washer
- 86 Poppet
- 87 Spring check
- 88 Plug

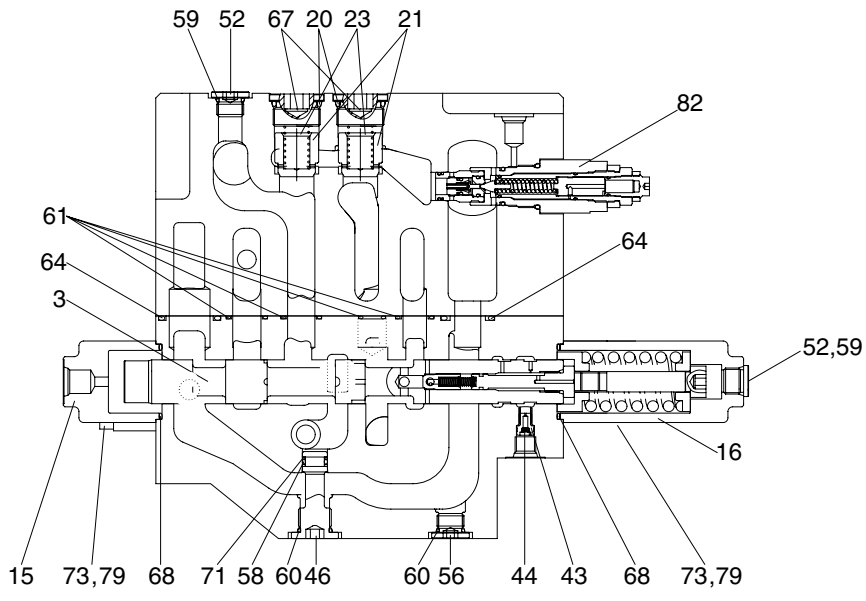

A-A' (STRAIGHT-TRAVEL & SUPPLY)

- 3 Spool-straight
- 4 Spool-travel
- 15 Cover-pilot A
- 16 Cover-pilot B1
- 20 Plug
- 21 Poppet 1-check valve
- 23 Spring 1-check valve
- 24 Plug
- 43 Orifice-signal
- 44 Coin type filter
- 46 Plug
- 47 Plug
- 52 Plug
- 56 Plug
- 57 O-ring
- 58 O-ring
- 59 O-ring
- 60 O-ring
- 61 O-ring
- 64 O-ring
- 65 O-ring
- 67 O-ring
- 68 O-ring
- 71 Back-up ring
- 73 Hex socket head bolt
- 79 Washer
- 82 Main relief valve
- 83 Main relief valve

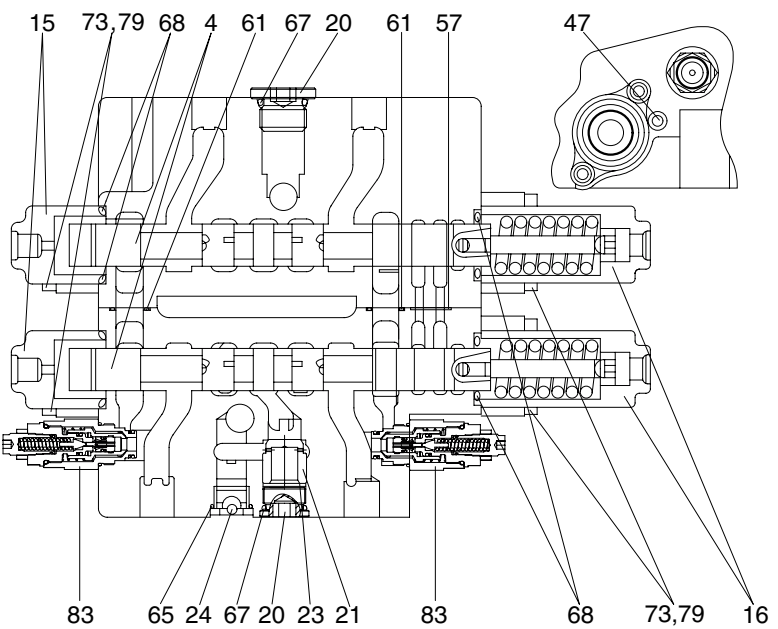

B-B' (TRAVEL RIGHT & LEFT)

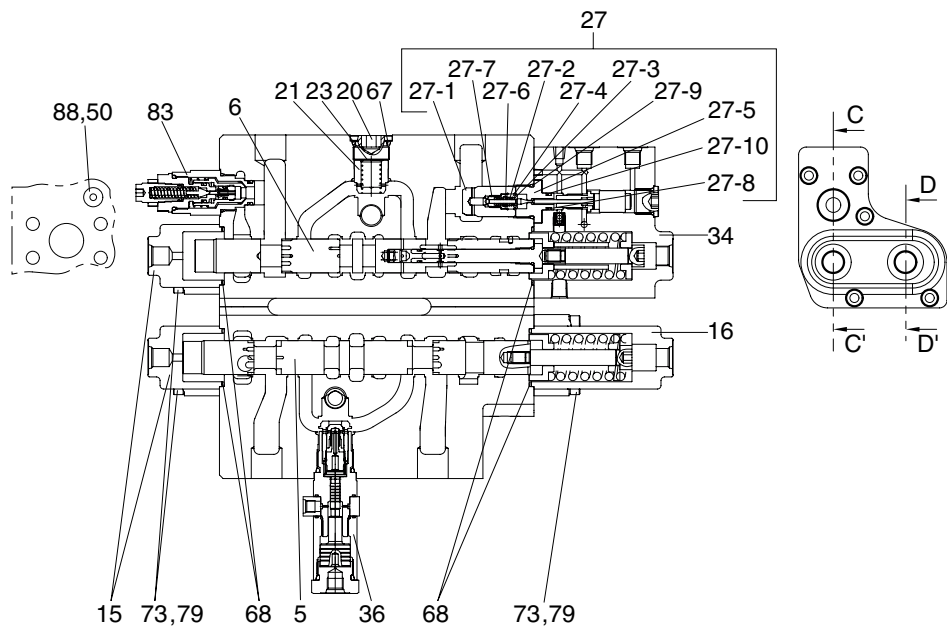

C-C' (SWING & BOOM1)

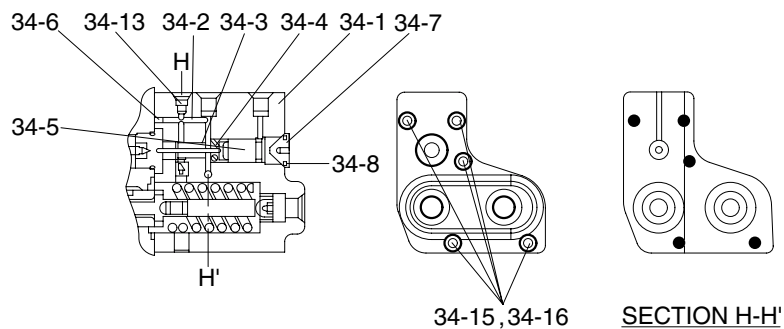

34 DETAIL (HOLDING ASSY)

5	Spool-swing	27-7	Restrictor-lock valve	34-14	Plug
6	Spool-boom	27-8	O-ring	34-15	Socket bolt
15	Cover-pilot A	27-9	O-ring	34-16	Spring washer
16	Cover-pilot B1	27-10	Back up ring	36	Logic valve
20	Plug	34	Holding kit-A1	50	O-ring
21	Poppet 1-check valve	34-1	Block-H/D P1	56	O-ring
23	Spring 1-check valve	34-2	Piston 1-holding	66	O-ring
27	Holding kit-B	34-3	Guide piston-holding	67	O-ring
27-1	Poppet	34-4	Spring 1-lock valve	68	O-ring
27-2	Spring	34-5	Piston 2-holding	70	Back-up ring
27-3	Poppet guide	34-6	Plug	73	Hex socket head bolt
27-4	Pilot poppet	34-7	Plug	79	Washer
27-5	Poppet seat	34-8	Plug	83	Overload relief valve
27-6	C-ring	34-13	Plug	88	Plug

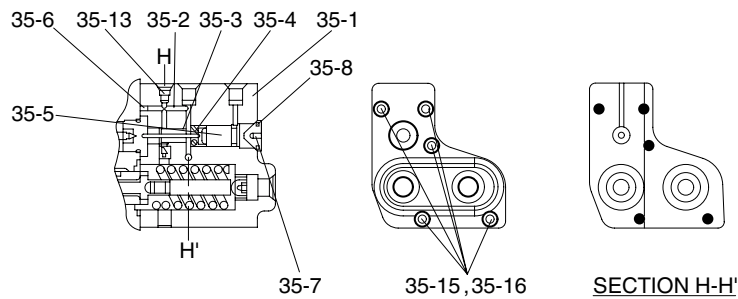
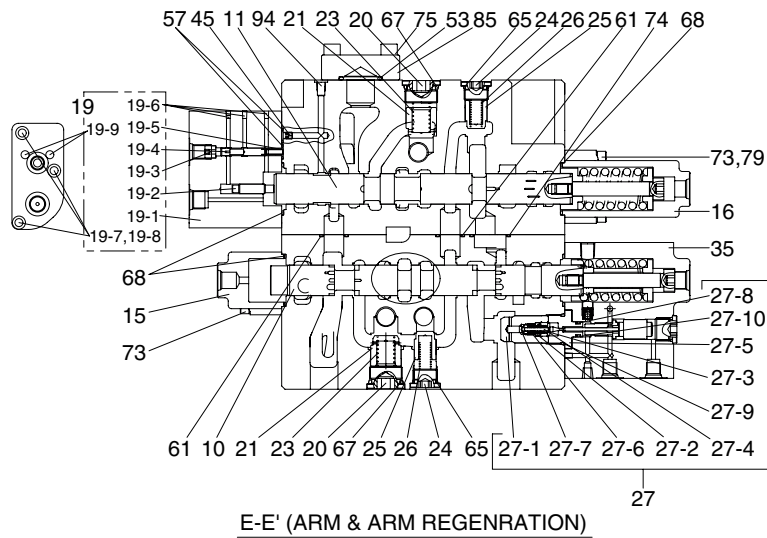

35 DETAIL (HOLDING ASSY)

10	Spool-arm	27	Poppet-lock valve	35-13	Plug
11	Spool-arm regeneration	27-1	Poppet	35-15	Socket bolt
15	Cover-pilot A	27-2	Spring	35-16	Spring washer
16	Cover-pilot B1	27-3	Poppet guide	45	Orifice-plug
19	Arm-regeneration	27-4	Pilot poppet	53	Flange
19-1	Block-regeneration	27-5	Poppet seat	56	O-ring
19-2	Piston-cut off	27-6	C-ring	57	O-ring
19-3	Stopper-regeneration	27-7	Restrictor-lock valve	61	O-ring
19-4	Spool-regeneration	27-8	O-ring	65	O-ring
19-5	Spring-regeneration	27-9	O-ring	66	O-ring
19-6	Plug	27-10	Back up ring	67	O-ring
19-7	Socket bolt	35	Holding kit-A2	68	O-ring
19-8	Spring wahser	35-1	Block-H/D P2	70	Back-up ring
19-9	Pin-regeneration	35-2	Piston 1-holding	73	Hex socket head bolt
20	Plug	35-3	Guide piston-holding	74	O-ring
21	Poppet 1-check valve	35-4	Spring 1-lock valve	75	Socket bolt
23	Spring 1-check valve	35-5	Piston 2-holding	79	Washer
24	Plug	35-6	Plug	85	O-ring
25	Poppet 2-check valve	35-7	Plug		
26	Spring 2-check valve	35-8	Plug		

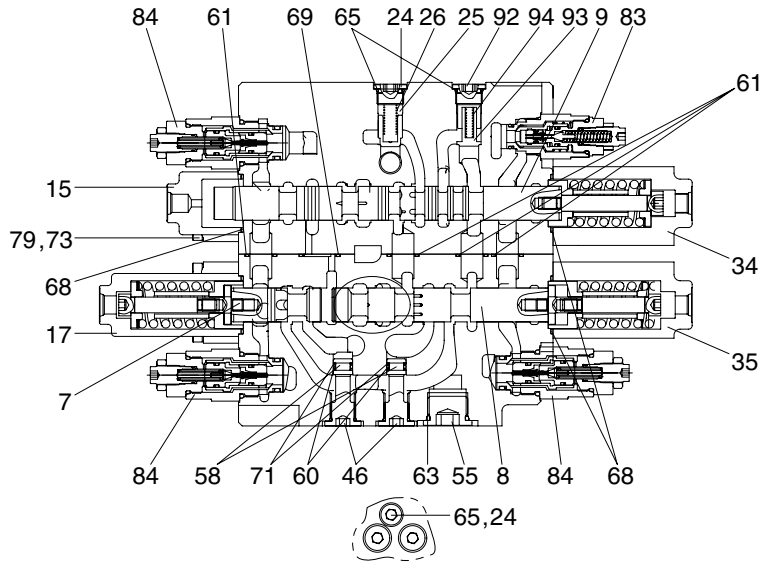

D-D' (SWING PRIORITY-BOOM2 & ARM2)

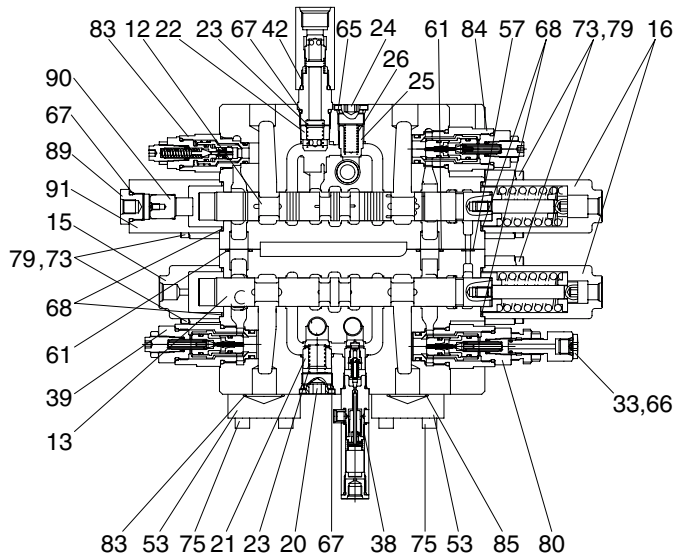

F-F' (OPTION & BUCKET)

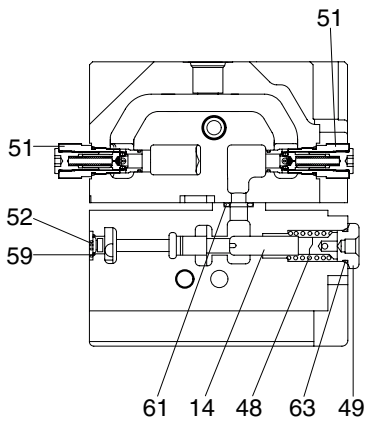

G-G' (CENTER BYPASS CUT-OFF & NEGATIVE CONTROL)

- 7 Spool-swing priority
- 8 Spool-boom 2
- 9 Spool-arm 2
- 12 Spool-bucket
- 13 Spool-option
- 14 BC spool
- 15 Cover-pilot A
- 16 Cover-pilot B1
- 17 Cover-pilot B2
- 20 Plug
- 21 Poppet 1-check valve
- 22 Poppet L/C-bucket
- 23 Spring 1-check valve
- 24 Plug
- 25 Poppet 2-check valve
- 26 Spring 2-check valve
- 34 Holding kit
- 35 Holding kit
- 38 Load check valve assy
- 39 Overload relief valve
- 42 Check valve
- 46 Plug
- 48 Spring-BC spool
- 49 Plug-BC spool
- 51 Negative control valve
- 52 Plug
- 53 Flange
- 55 Plug
- 57 O-ring
- 58 O-ring
- 59 O-ring
- 60 O-ring
- 61 O-ring
- 63 O-ring
- 65 O-ring
- 67 O-ring
- 68 O-ring
- 69 O-ring
- 71 Back-up ring
- 73 Hex socket head bolt
- 75 Socket bolt
- 79 Washer
- 80 Overload relief valve
- 83 Overload relief valve
- 84 Overload relief valve
- 85 O-ring
- 89 Plug
- 90 Piston
- 91 Pilot cover C1
- 92 Plug
- 93 Poppet
- 94 Spring

2. HYDRAULIC CIRCUIT

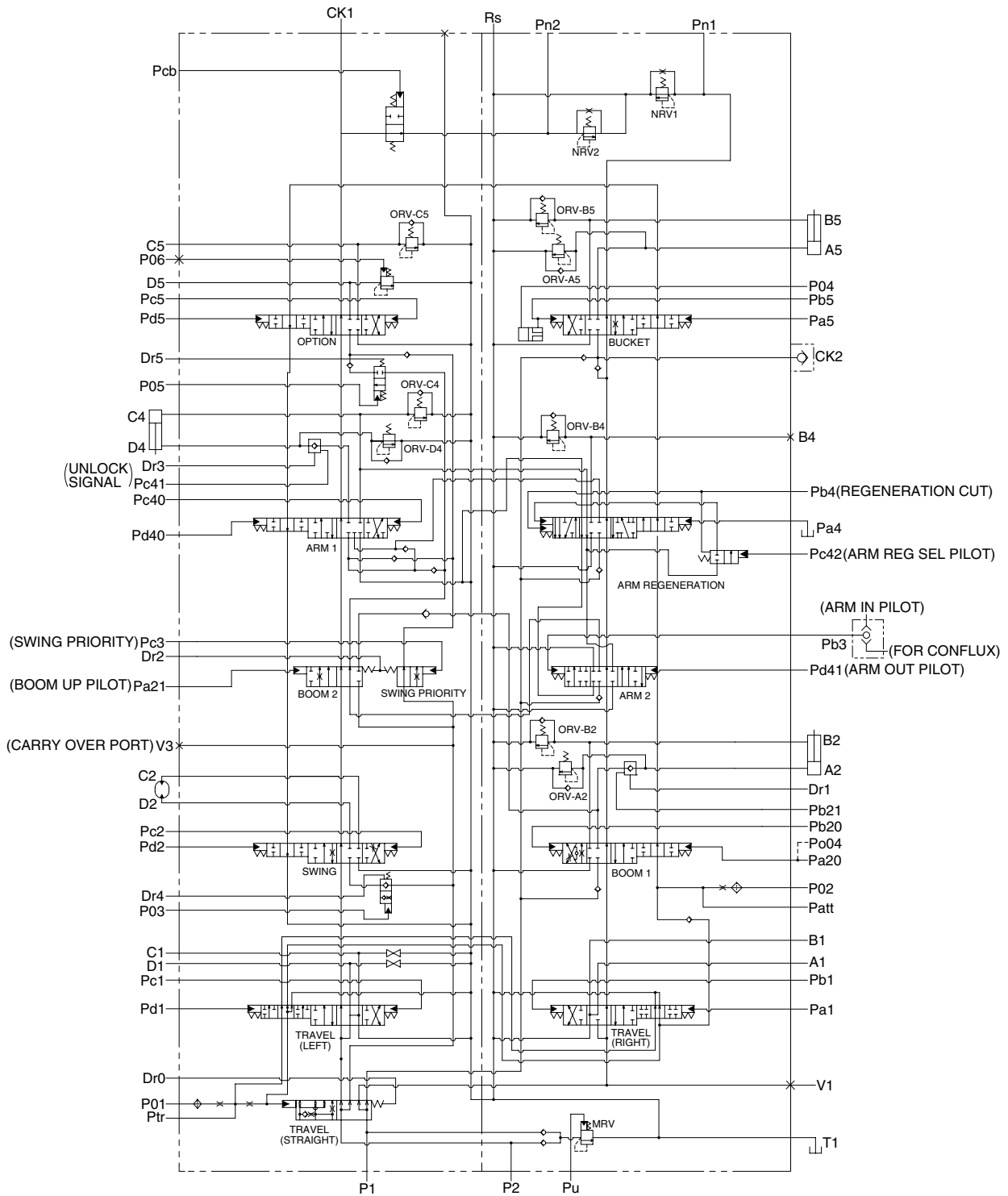

3. FUNCTION

1) CONTROL IN NEUTRAL

(1) P1 SIDE

The hydraulic fluid from pump flows into the main control valve through the inlet port "P1", pass the land of the travel straight spool, into the P1 bypass passage and P1 parallel passage. When the straight travel spool is in neutral position, the bypass passage is not shut off. Then the hydraulic fluid from the pump P1 is directed to the tank through the bypass passage of spools : travel right, boom 1, arm 2, arm regeneration & option A and bucket, the negative relief valve of P1, tank passage, and the tank port "T1"

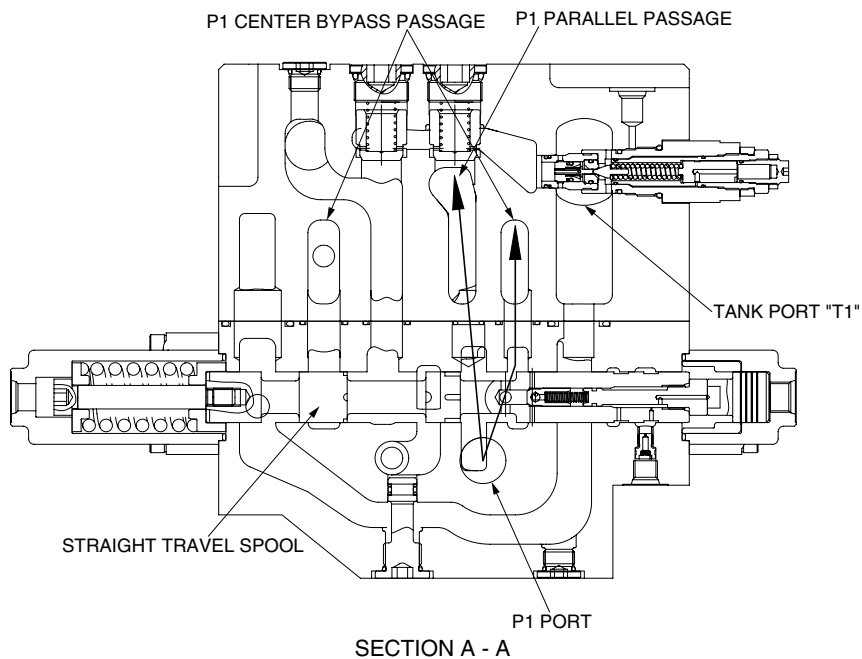
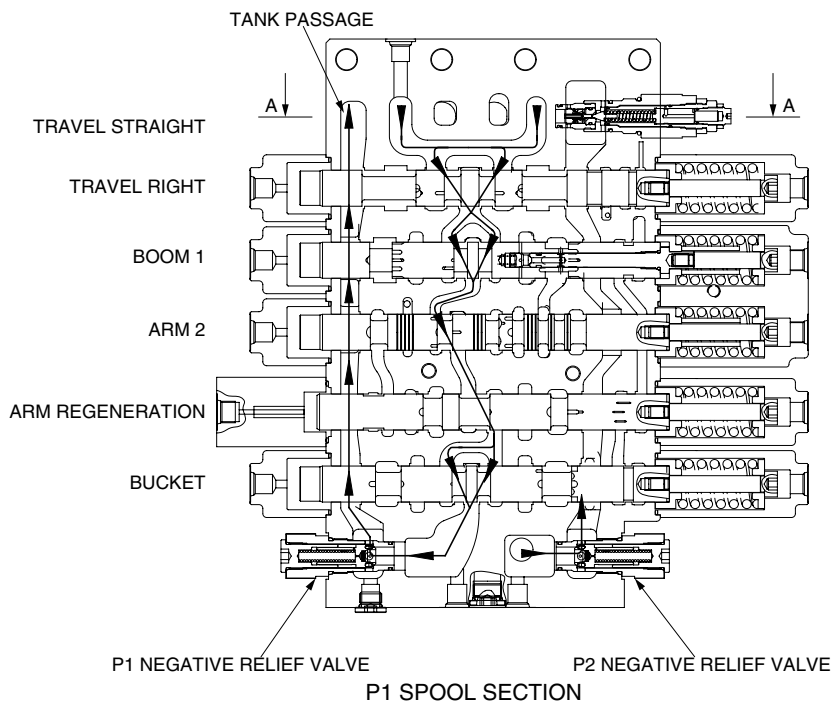

(2) P2 SIDE

The hydraulic fluid from pump flows into the main control valve through the inlet port "P2", pass the land of the straight travel spool, into the P2 bypass passage and P2 parallel passage. When the straight travel spool is in neutral position, the bypass passage is not shut off. Then the hydraulic fluid from the pump P2 is directed to the tank through the bypass passage of spools : travel left, swing, boom 2 & swing priority, arm 1, option "B" and option "C" of bypass passage summation, and the negative relief valve of P2, the tank passage and the tank port "T1".

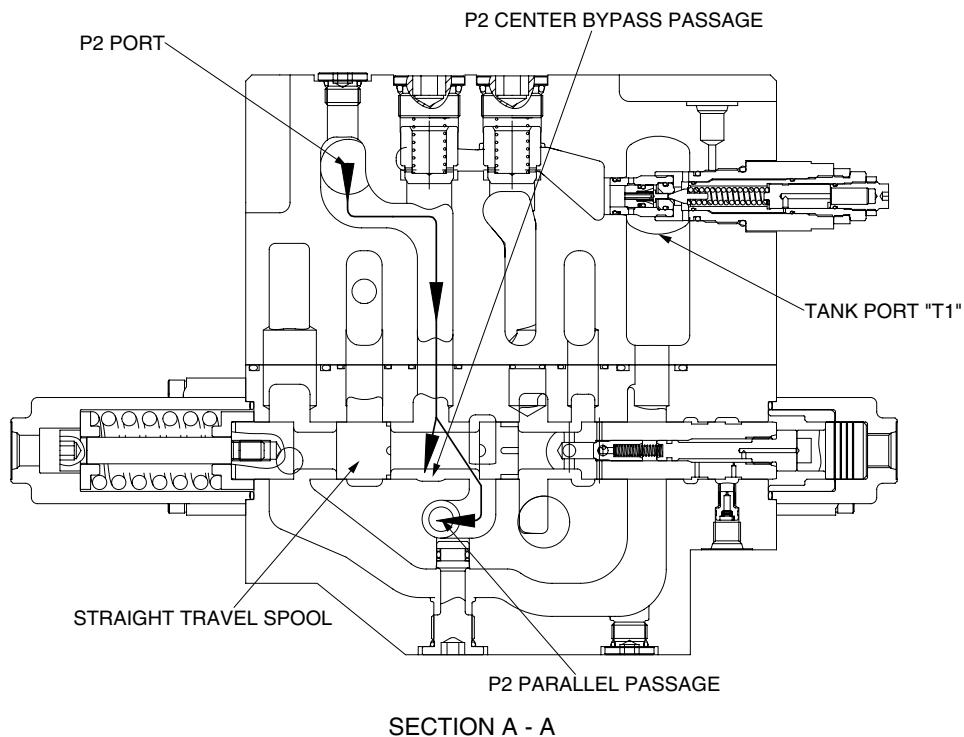
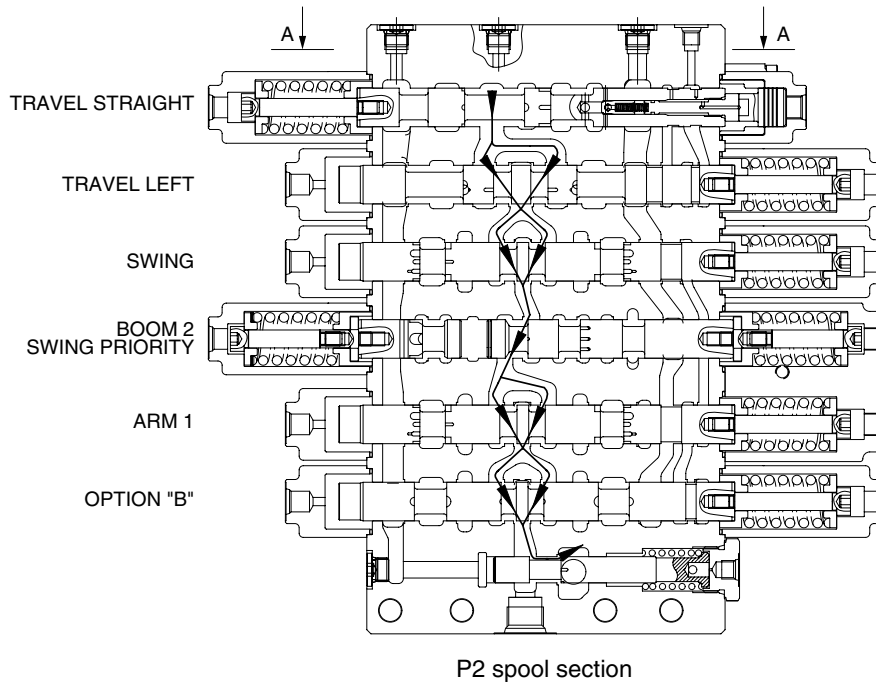

2) TRAVEL OPERATION

(1) TRAVEL FORWARD OPERATION

During the travel forward operation, the pilot pressure of RCV is supplied to the port of the spring side, and it shifts travel right and left spools in the left direction against springs. Hydraulic fluid from the pump flows into the bypass passage of travel spool through the land of the straight travel spool.

Then the bypass passage is shut off by the movement of the spool, they are directed to the each travel motor through port B1 and D1. At the same time, the hydraulic fluid from the each travel motor through port A1 and C1 returns to the tank passage through the travel spools.

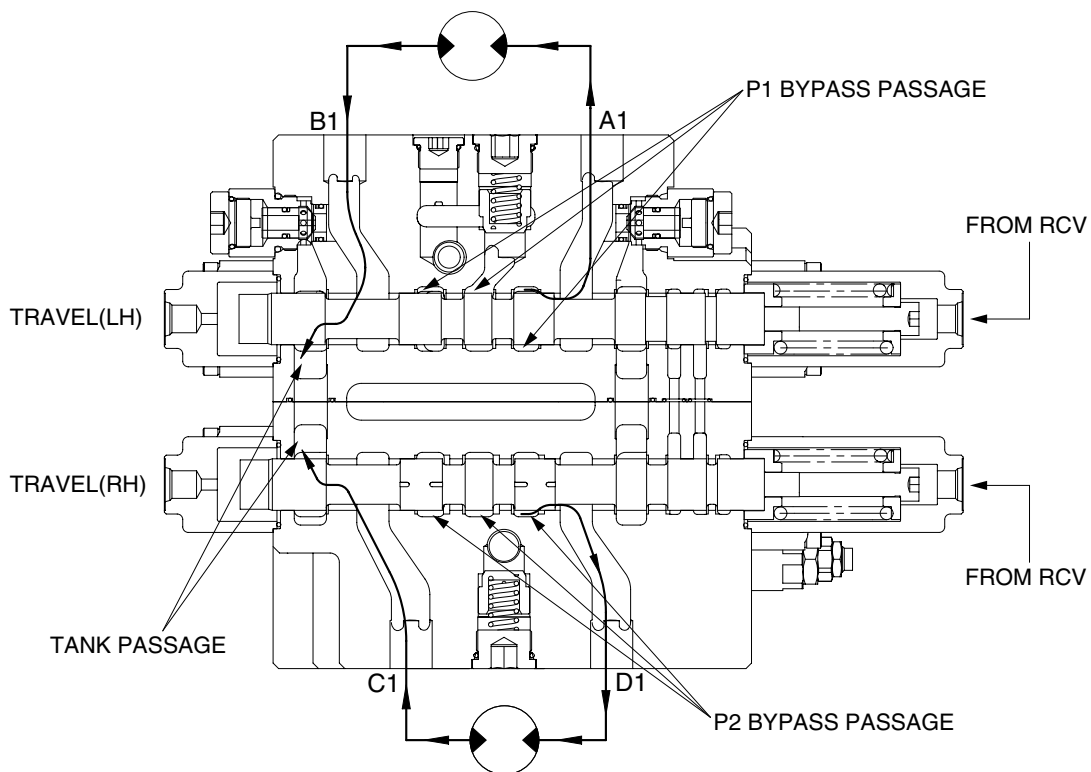

(2) TRAVEL REVERSE OPERATION

During the travel reverse operation, the pilot pressure of RCV is supplied to the port of the spring opposite side, and it shifts travel right and left spools in the right direction against springs. Hydraulic fluid from the pump flows into the bypass passage of travel spool through the land of the straight travel spool.

Then the bypass passage is shut off by the movement of the spool, they are directed to the each travel motor through port A1 and C1. At the same time, the hydraulic fluid from the each travel motor through port B1 and D1 returns to the tank passage through the travel spools.

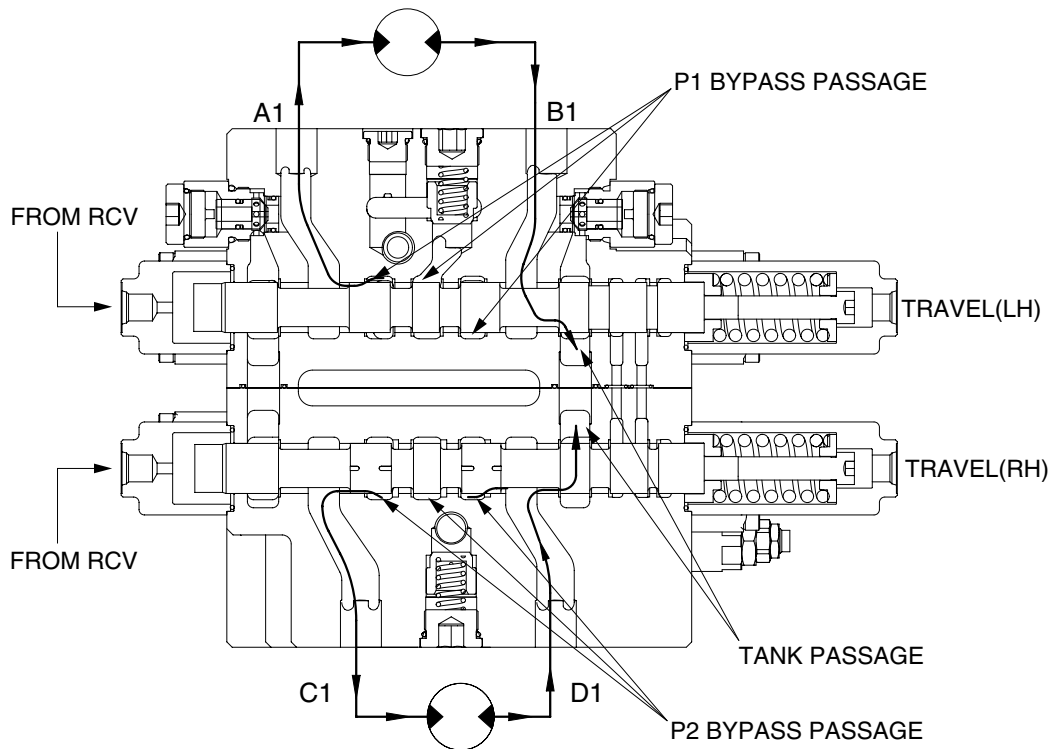

(3) TRAVEL STRAIGHT FUNCTION

Straight travel valve is the valve for keeping traveling straight when boom, arm, bucket or swing is operated at the time of traveling. Therefore the oil from the P1 and P2 pump flows into the control valve through the each passage in neutral condition.

When the both travels and any of attachment is switched, the pilot pressure is applied the port of spring chamber and the travel straight spool is shifted.

When the straight travel spool is shifted, the oil pressure from P1 is led to the each attachment switching section through the P1 and P2 parallel passage. Also some of oil is combined with bypass of P1 side by opening of check valve of spool inside through the orifice of the straight travel spool.

On the other hand, the oil from P2 is supplied to the both travel section through P1 and P2 bypass passage.

Therefore, when attachment is switched at the time of both travels, since the oil of P2 mainly flows to both travels, and the oil of P1 mainly flows to attachments, it can keep traveling straight.

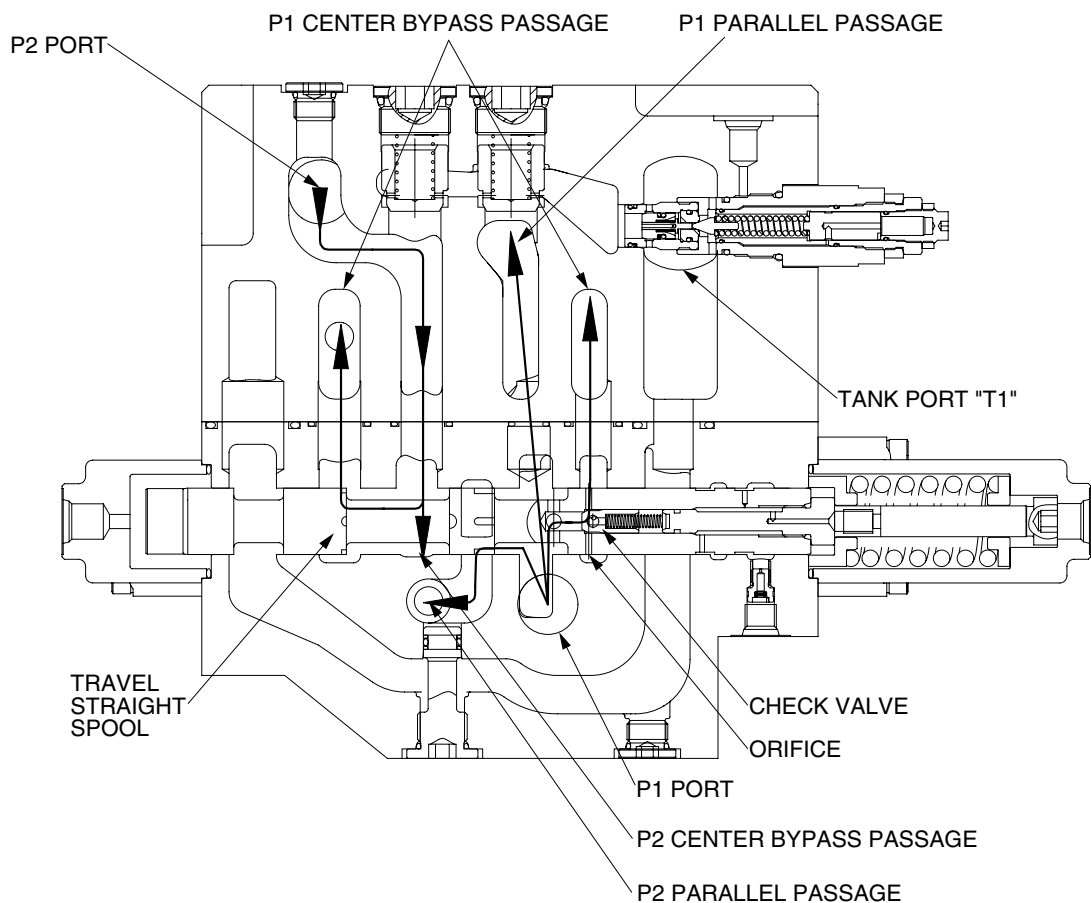

3) BOOM OPERATION

(1) BOOM UP OPERATION

During boom up operation, the pilot secondary pressure from RCV is supplied to the port of the spring side and shifts the boom 1 spool in the left direction. The bypass passage is shut off by the movement of the spool and the hydraulic oil fluid from pump P1 is entered P1 parallel passage and then passes through the load check valve, bridge passage and boom holding valve then flows into the port A2.

Following this it flows into the head side of the boom cylinder.

(In this case, the boom holding valve is free flow condition)

At the same time, the pilot pressure from RCV is supplied to the port of the spring side of boom 2 and shifts the boom 2 spool. The bypass passage is shut off by the movement of the spool and the hydraulic oil fluid from pump P2 entered boom summation passage via the P2 parallel passage, the land of the swing priority spool, notch of the boom 2 spool, arm 2 spool and the check. The flows combine in passage and are directed to port A2 and head side of boom cylinder. At the same time, the flow from rod side of the boom cylinder return to the boom 1 spool through the port B2. There after it is directed to the hydraulic oil tank through the tank passage.

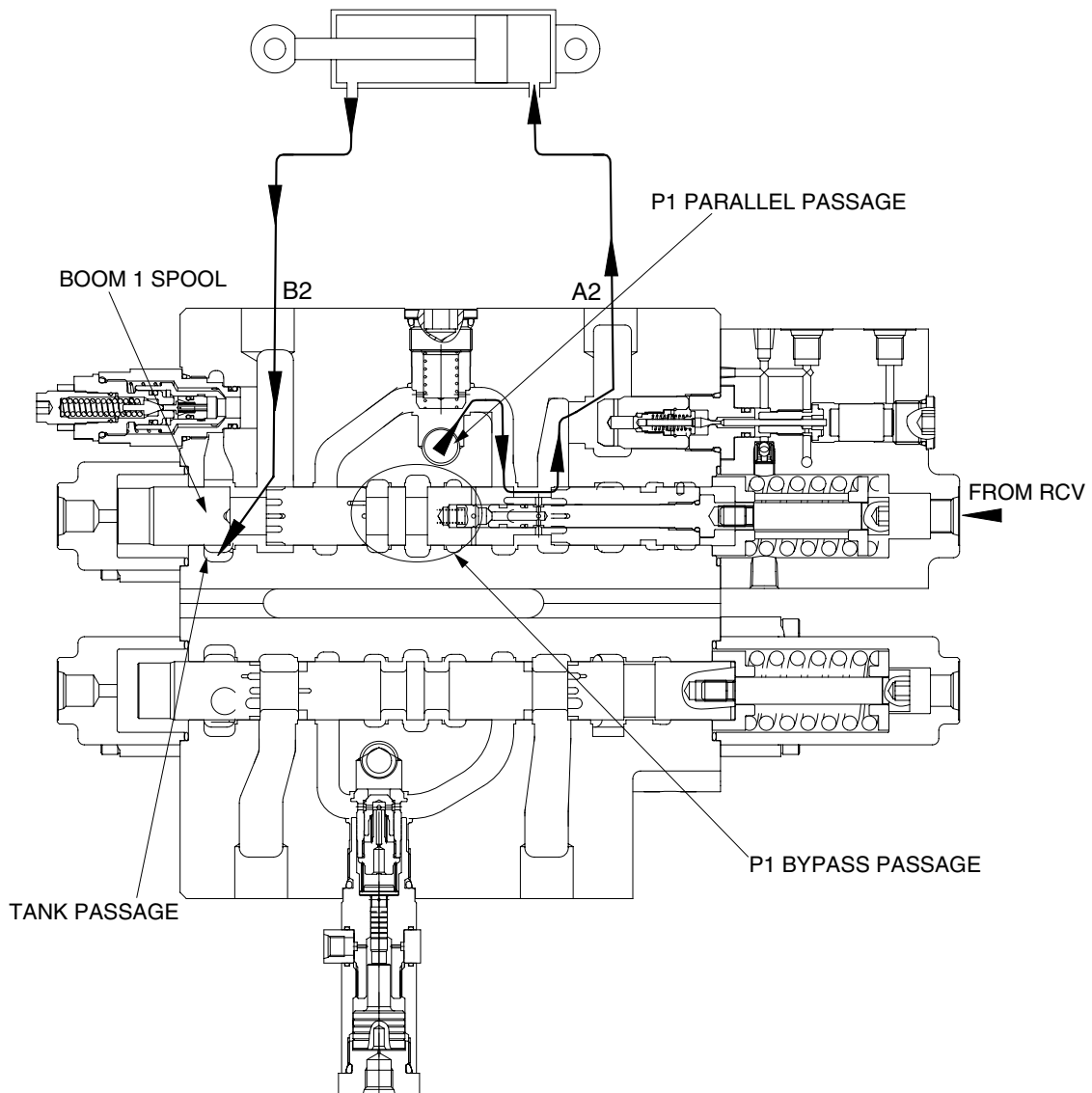

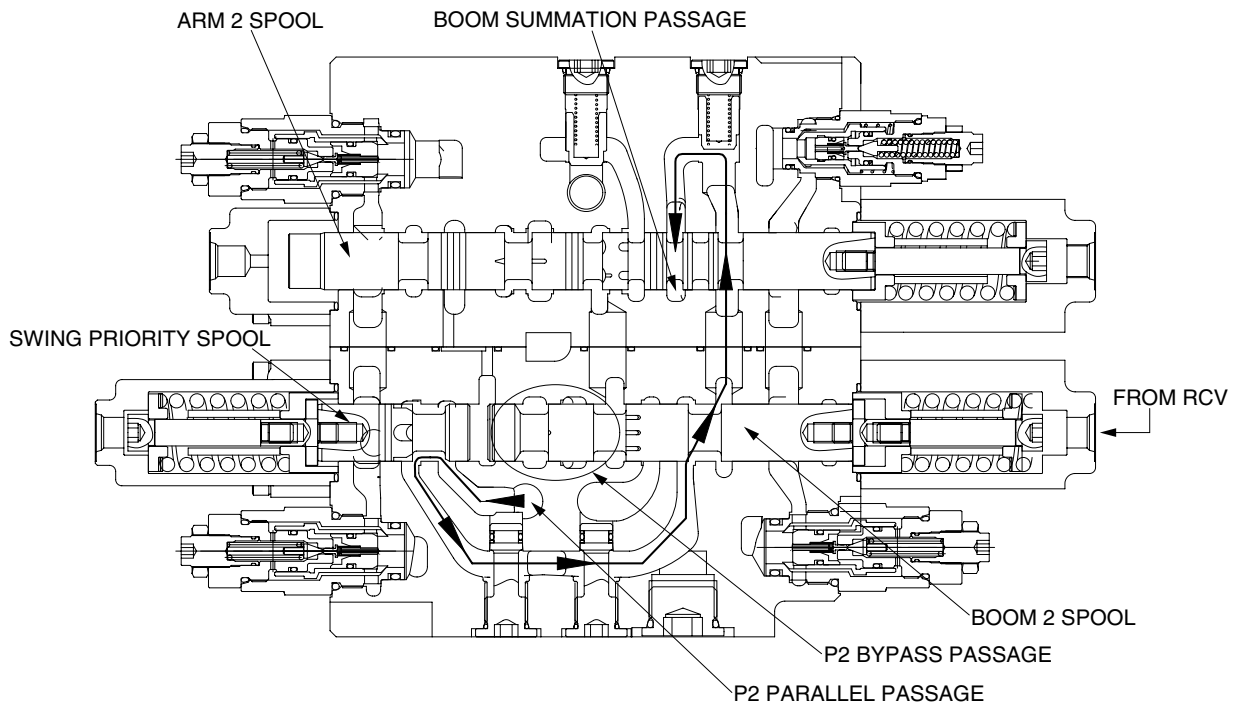

(2) BOOM DOWN OPERATION

During the boom lowering operation, the pilot pressure from RCV is supplied to the port of the spring opposite side and shifts the boom 1 spool in the right direction.

The bypass passage is shut off by the movement of the spool and the hydraulic fluid from the pump P1 enters the parallel passage and is directed to the port B2 through the load check valve. Following this, it flows into the rod side of the boom cylinder.

At the same time, the return flow from the head side of the boom cylinder returns to the port A2 and boom holding valve. And it is directed to the hydraulic oil tank through opened tank passage by movement of the boom 1 spool.

Meanwhile some of return flow is directed to P1 parallel passage through the internal passage of the boom 1 spool. (boom regeneration)

In this case, the holding valve is open condition, for details of the boom holding valve, see page following page.

During the boom lowering operation, the fluid from P2 pump is not summation.

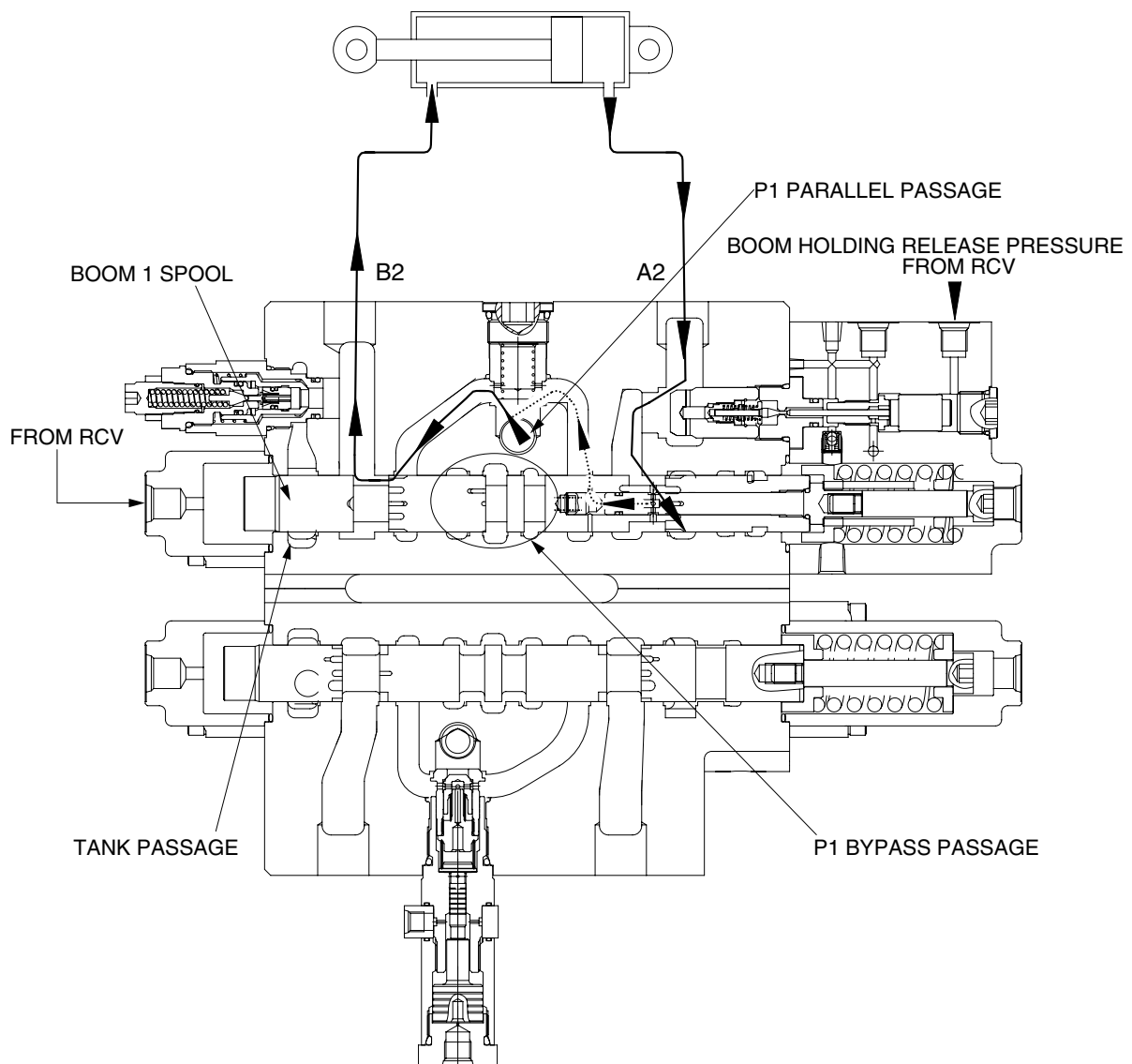

4) HOLDING VALVE OPERATION

(1) HOLDING OPERATION

At neutral condition, the pilot piston chamber is connected to drain port through the pilot port.

And the piston "B" is supported with spring "B".

Also, the pressured fluid from actuator entered to inside of the holding valve through the periphery hole of check, crevice of the check and the plug and the periphery hole of plug.

Then, this pressured oil pushed the poppet to the poppet seat and the check to the seat of body.

So the hydraulic fluid from actuator is not escaped and the actuator is not moved.

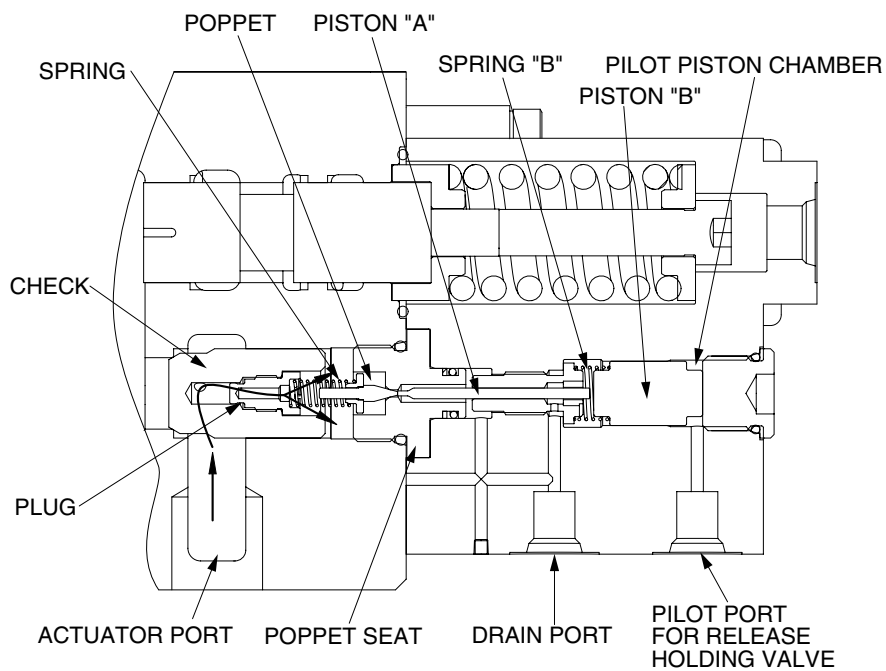

(2) RELEASE HOLDING OPERATION

The pilot pressure is supplied to the pilot port for release holding valve and shifts the piston "B" in the left direction against the spring "B", and shifts the poppet in the left direction through piston "B" and piston "A" against spring "B" and shifts the spool in the left side.

At same time, the return fluid from actuator returns to the drain port through the periphery hole of check, crevice of the check and the plug, the periphery hole of the plug, in side of holding valve, crevice of the poppet and the poppet seat, the periphery hole of the poppet seat, crevice of socket and spool and internal passage of spool.

When the poppet is opened, pressure of inside of holding valve is decreased and the return fluid from actuator returns to the tank passage through the notch of spool.

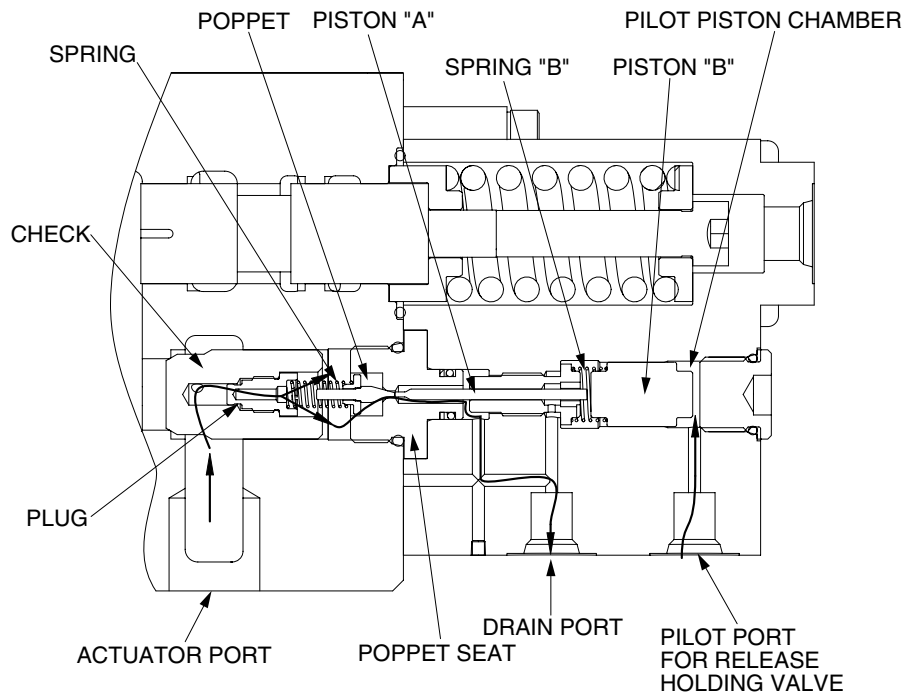

5) BUCKET OPERATION

(1) BUCKET IN OPERATION

① Bucket operation only

During the bucket in operation, the pilot secondary pressure from RCV is supplied to port of the spring side and shifts the bucket spool in the left direction.

The bypass passage is shut off by the movement of the spool and the hydraulic fluid from pump P1 entered P1 parallel passage and is directed to the port A5 through the check2.

At the same time, the hydraulic fluid from P1 bypass passage is directed to the port A5 through the check1.

Following this it flows into the head side of the bucket cylinder.

The return flow from the rod side of the bucket cylinder returns to the bucket spool through the port B5. Thereafter it is directed to the hydraulic oil tank through the tank passage.

② Bucket operation with arm or boom operation

When combined operation, mostly same as above but the fluid from bypass passage is empty.

So only the fluid from parallel passage is supplied to the bucket cylinder. Also, parallel passage is installed the orifice for supplying the fluid from pump to the boom or the arm operation prior to the bucket operation.

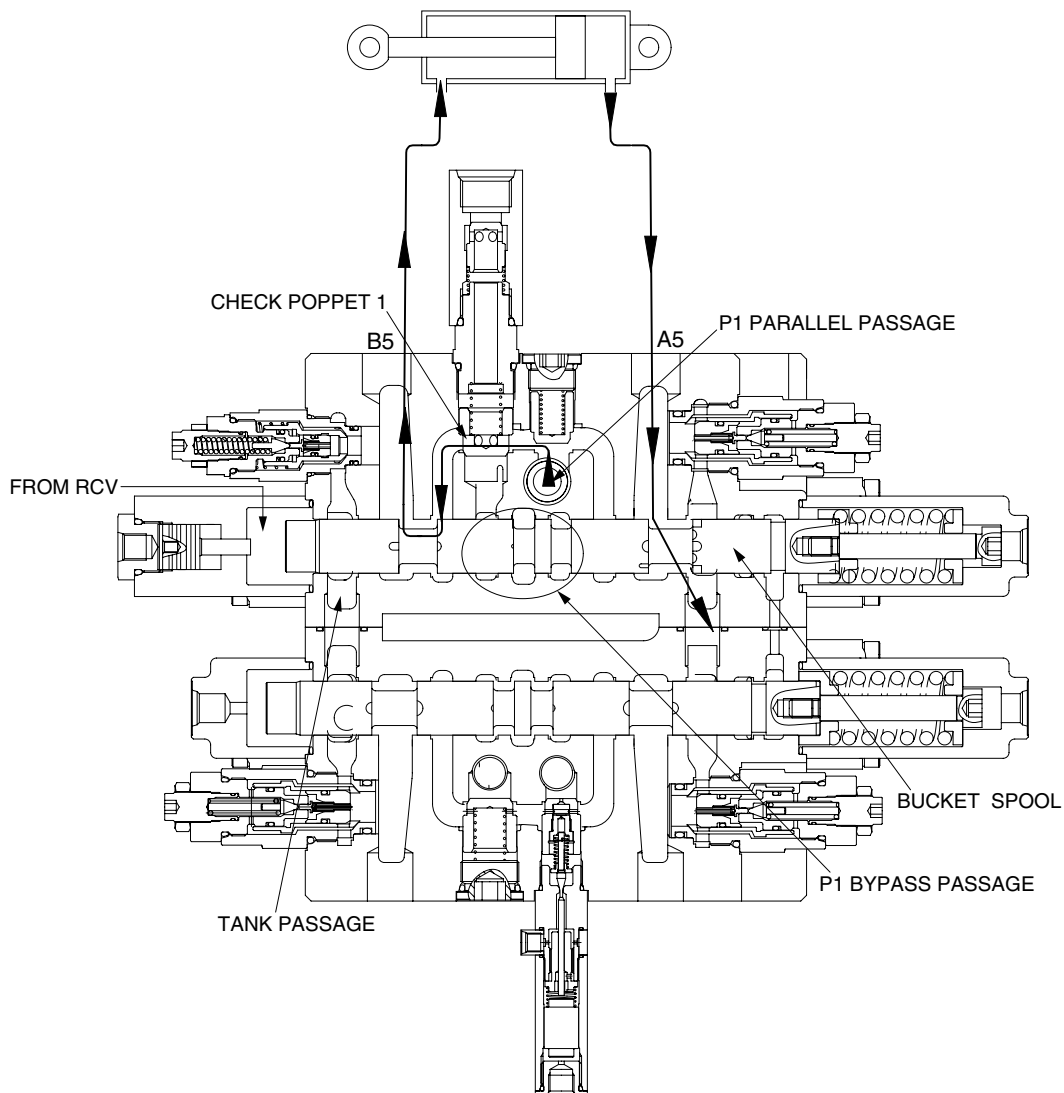

(2) BUCKET OUT OPERATION

① Bucket operation only

During the bucket out operation, the pilot secondary pressure from RCV is supplied to port of the spring opposite side and shifts the bucket spool in the left direction.

The bypass passage is shut off by the movement of the spool and the hydraulic fluid from pump P1 entered P1 parallel passage and is directed to the port B5 through the check1.

The return flow from the rod side of the bucket cylinder returns to the hydraulic oil tank through the tank passage and the port A5.

② Bucket operation with arm or boom operation

When combined operation, the same as above.

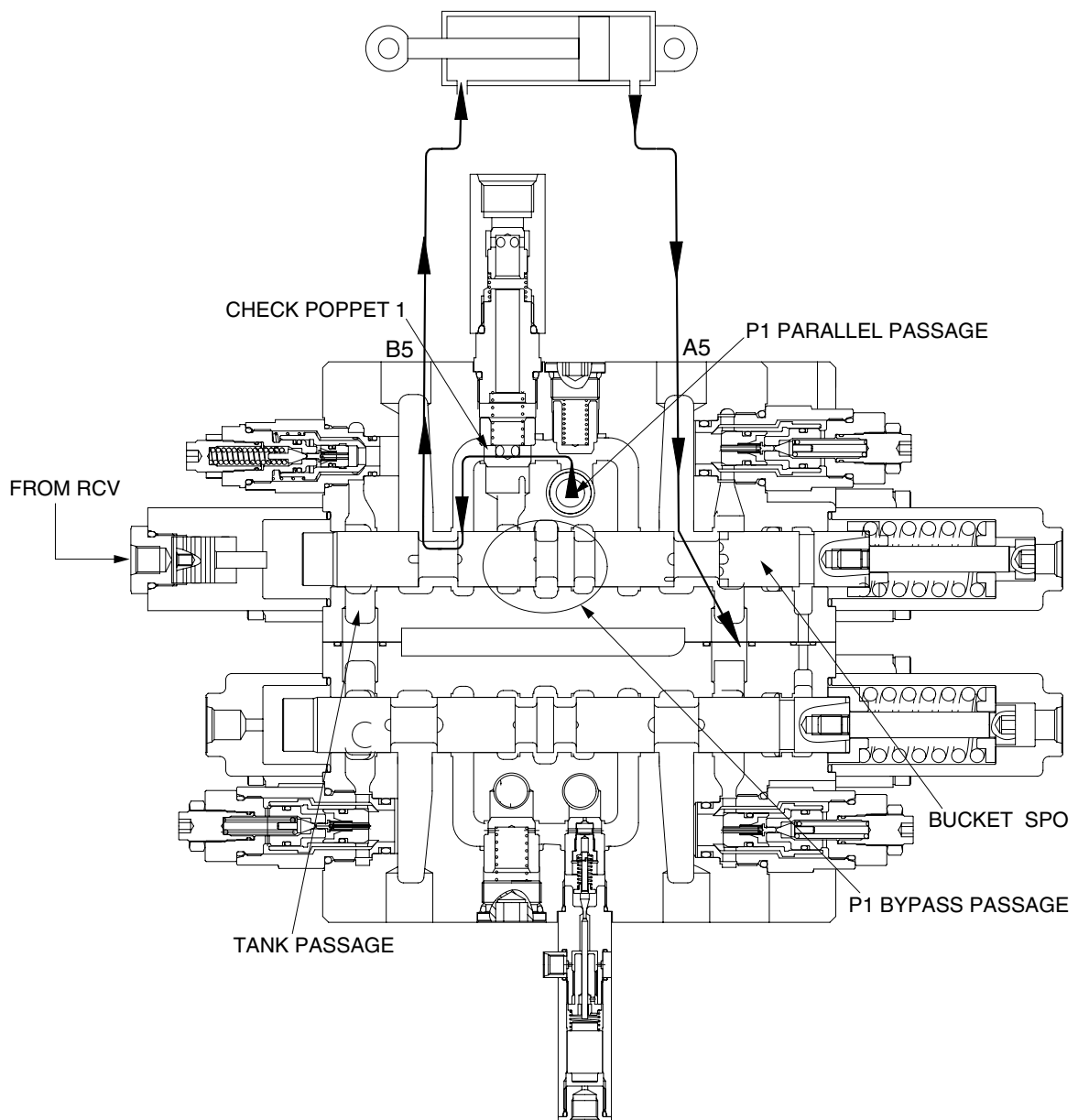

(3) BUCKET SLOW OPERATION

This function is used to speed up of the boom by reducing the bucket speed when bucket operation with boom operation simultaneously.

When the boom up operation, the boom up pilot pressure is supplied the pilot port of bucket spool stroke limit and the piston is shifted to the right and then the bucket spool stroke is limited and the open of the bucket spool is reduced.

Accordingly, the oil of the bucket spool is reduced and the boom speed up.

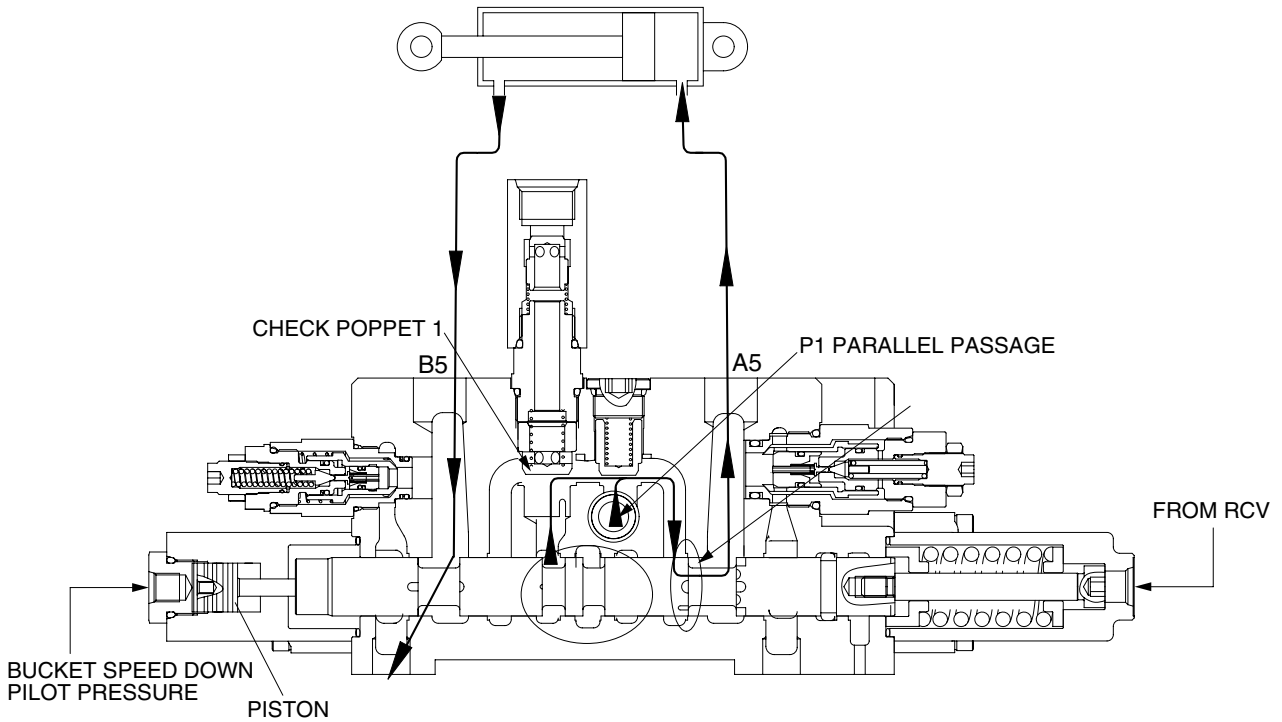

6) SWING OPERATION

(1) SWING LEFT & RIGHT OPERATION

During the swing left operation, the pilot secondary pressure from the RCV is supplied to the port of the spring side and shift the swing spool in left direction. The bypass passage is shut off by the movement of the spool and the hydraulic fluid from pump P2 flows into swing spool through the parallel passage. Then it is directed to swing motor through the port D2.

As the result, swing motor turns and flow from the swing motor returns to the hydraulic oil tank through the port C2, swing spool and the tank passage.

In case of swing right operation, the operation is similar to swing left operation but the pilot secondary pressure from the RCV is supplied to the port of the spring opposite side.

Accordingly, the hydraulic fluid from pump P2 flows into swing motor through the port C2 and returns to the hydraulic oil tank through the port D2 and the tank passage.

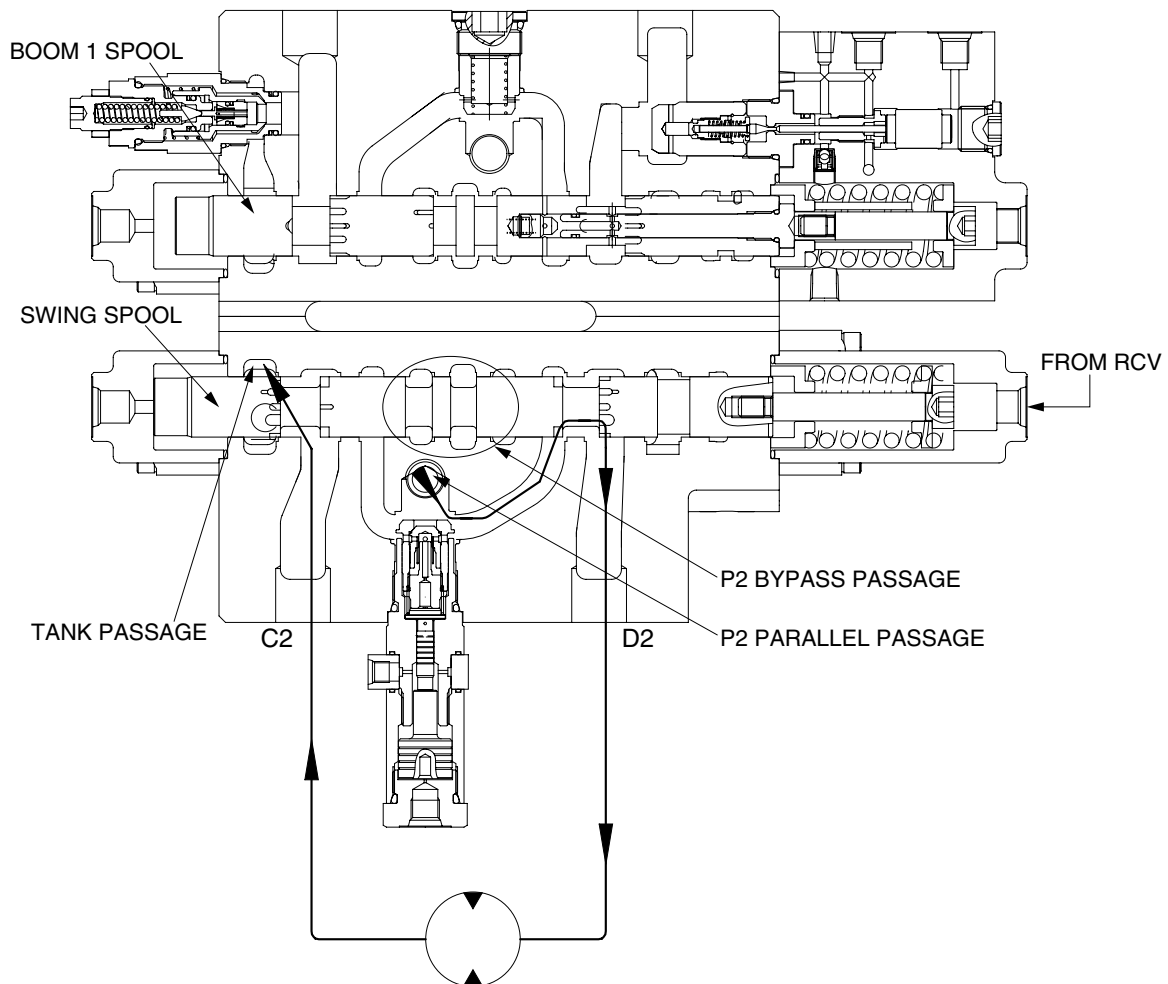

(2) SWING SLOW DOWN OPERATION

This operation is used to speed up the boom or arm by reducing the swing speed when swing operation with boom or arm operation.

The poppet of swing logic valve is closed by the pilot pressure of swing speed down is supplied to the port, the fluid from the port P2 is drained through orifice. Accordingly, the fluid from the port P2 is reduced and swing speed is slow down.

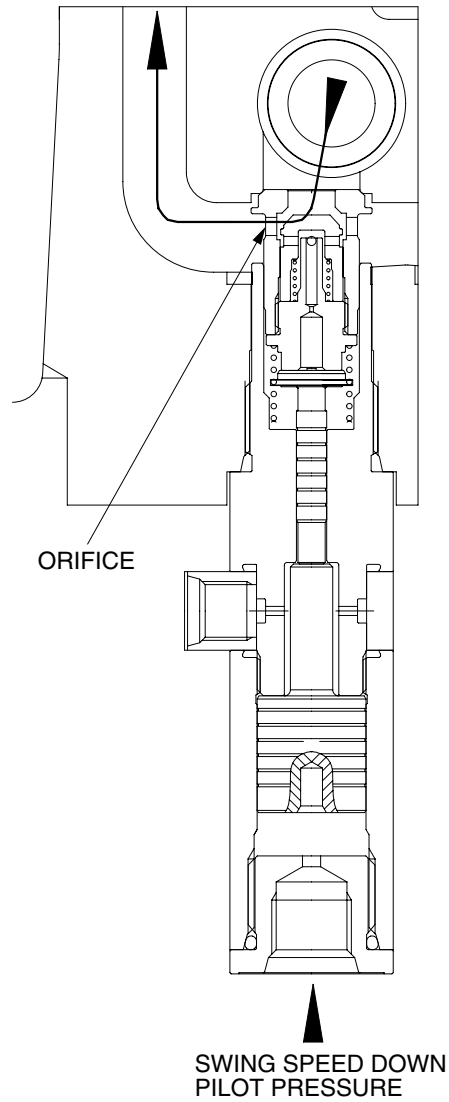

7) ARM OPERATION

(1) ARM IN OPERATION

During arm in operation, the pilot secondary pressure from the RCV is supplied to the port of spring opposite side and shifts arm 1 spool in the right direction.

The bypass passage is shut off by the movement of the arm 1 spool and the hydraulic oil from the pump P2 flows into the arm cylinder head side through P2 parallel passage, the load check valve, bridge passage and the port C4.

At same time, the pilot secondary pressure from the RCV is supplied to the port of spring opposite side and shifts arm 2 spool in the right direction. The bypass passage is shut off by the movement of the spool and the hydraulic fluid from the pump P1 flows into the arm summation passage through parallel passage, the check valve, the arm 2 spool and the boom 2 spool. Then it entered the arm cylinder head side with hydraulic fluid from arm 1 spool.

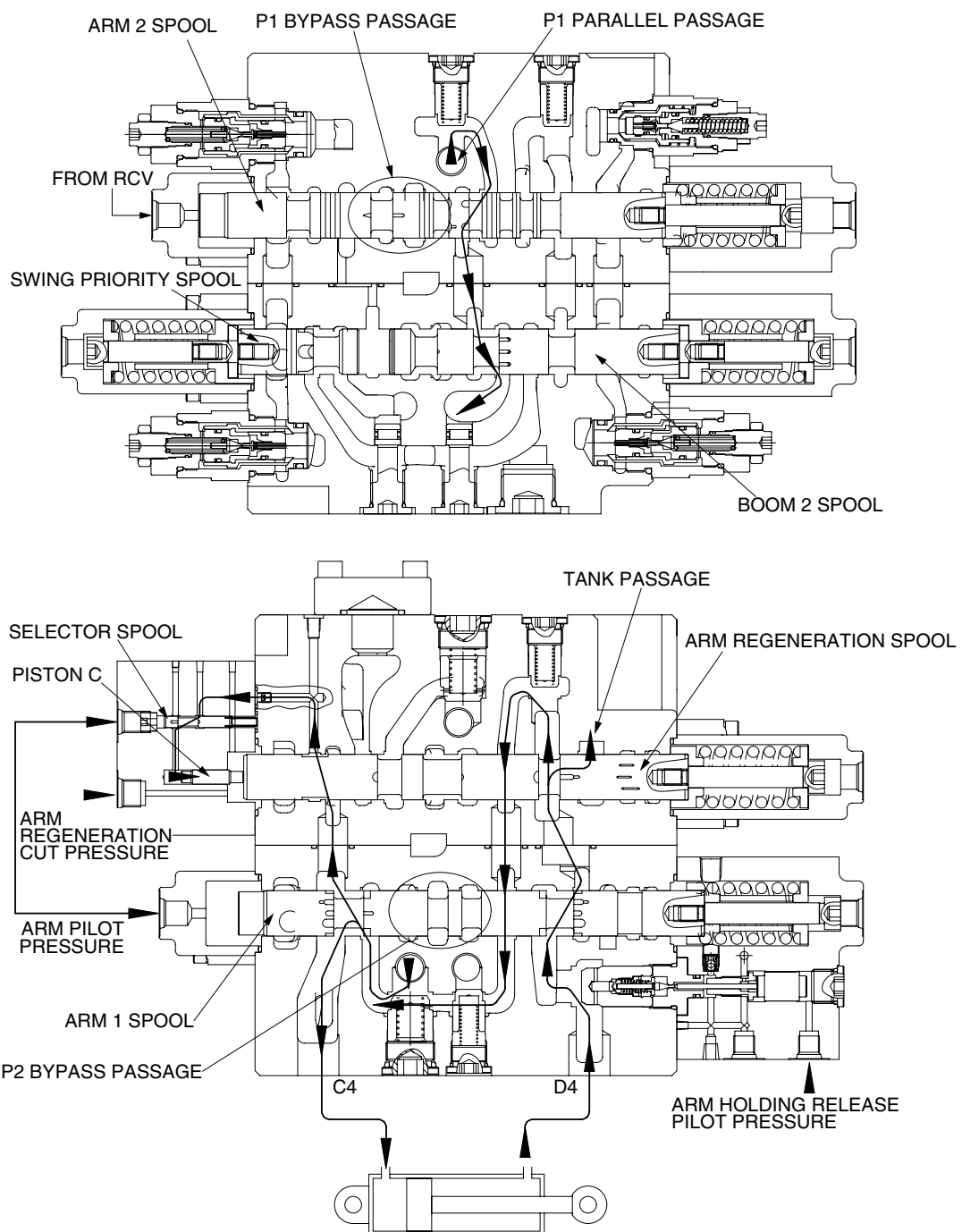

ARM REGENERATION

The return flow from the arm cylinder rod side is pressurized by self weight of arm and so, returns to port D4. The pressurized oil returning to port D4 enters the arm regeneration spool through the arm holding valve and the arm 1 spool. It is supplied the arm cylinder head through internal passage. This is called the arm regeneration function.

The amount of regeneration fluid is changed by movement of the arm regeneration spool. A few fluids after P2 parallel passage is push piston "C" through the notch of arm regeneration spool and selector spool. At this time, the selector spool is opened by pilot pressure from RCV.

Then, the arm regeneration spool shifts to right side and flow to tank pass increases and regeneration flow decreases. Therefore, pressure of arm cylinder head increases, then, arm regeneration flow decreases.

Furthermore, the arm regeneration cut pressure is supplied to the port of spring opposite side and arm regeneration spool is move into the right direction fully. The flow from the arm cylinder rod is returned to the hydraulic oil tank and regeneration function is not activated. (The return fluid is maximum condition)

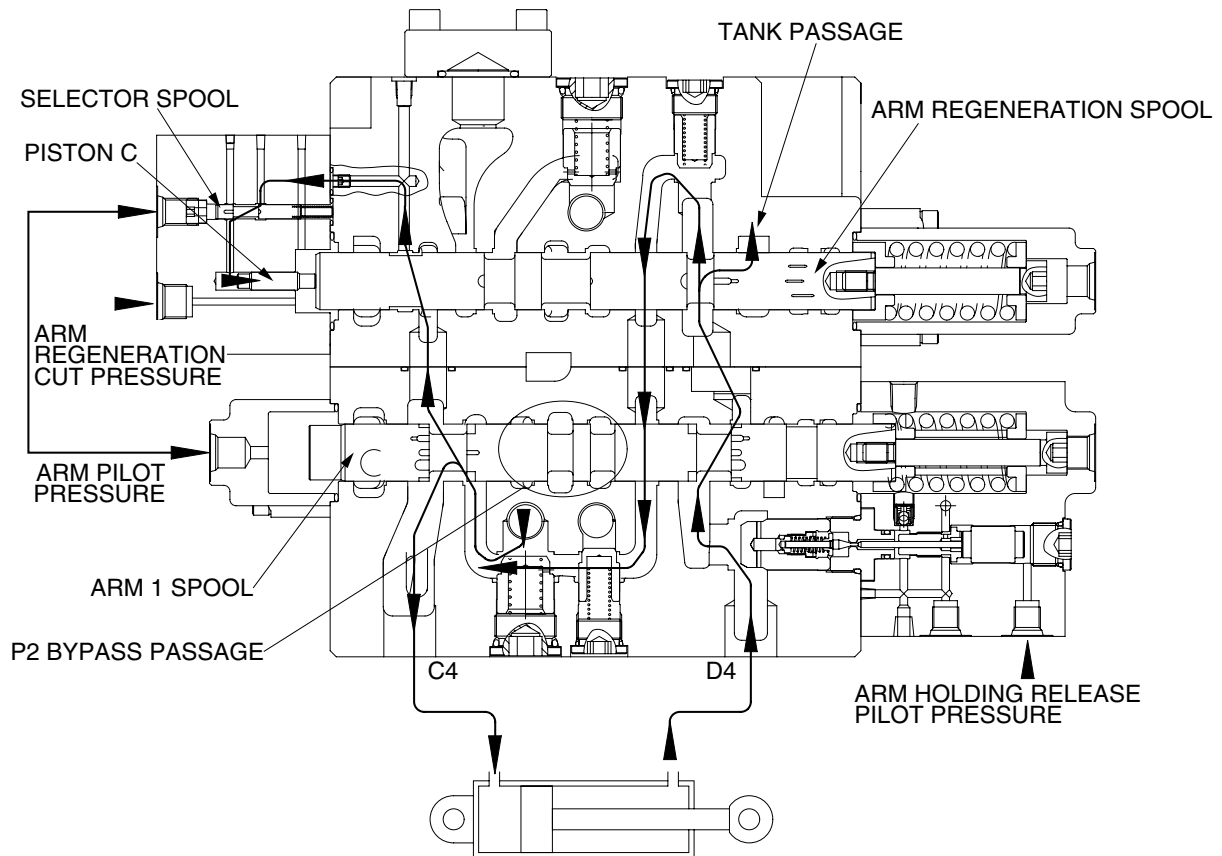

(2) ARM OUT OPERATION

During arm out operation, the pilot secondary pressure from RCV is supplied to the port of spring side and shifts arm 1 spool in the left direction.

The bypass passage is shut off by the movement of the spool and the hydraulic fluid from pump P2 flows into arm 1 spool through the parallel passage. Then it enters into the arm cylinder rod side through the load check valve, bridge passage, arm holding valve and the port D4.

Also, the pilot secondary pressure from RCV is supplied to the port of spring side and shifts arm 2 spool in the left direction.

The bypass passage is shut off by the movement of the spool and some of the hydraulic fluid from pump P2 bypassed through bypass notch. The rest of hydraulic fluid from pump P2 flows into the arm summation passage through P1 parallel passage the check valve arm 2 spool and boom 2 spool.

Then it enters into the arm cylinder rod side with the fluid from the arm 1 spool.

The return flow from the arm cylinder head side returns to the hydraulic tank through the port C4 the arm 1 spool and tank passage.

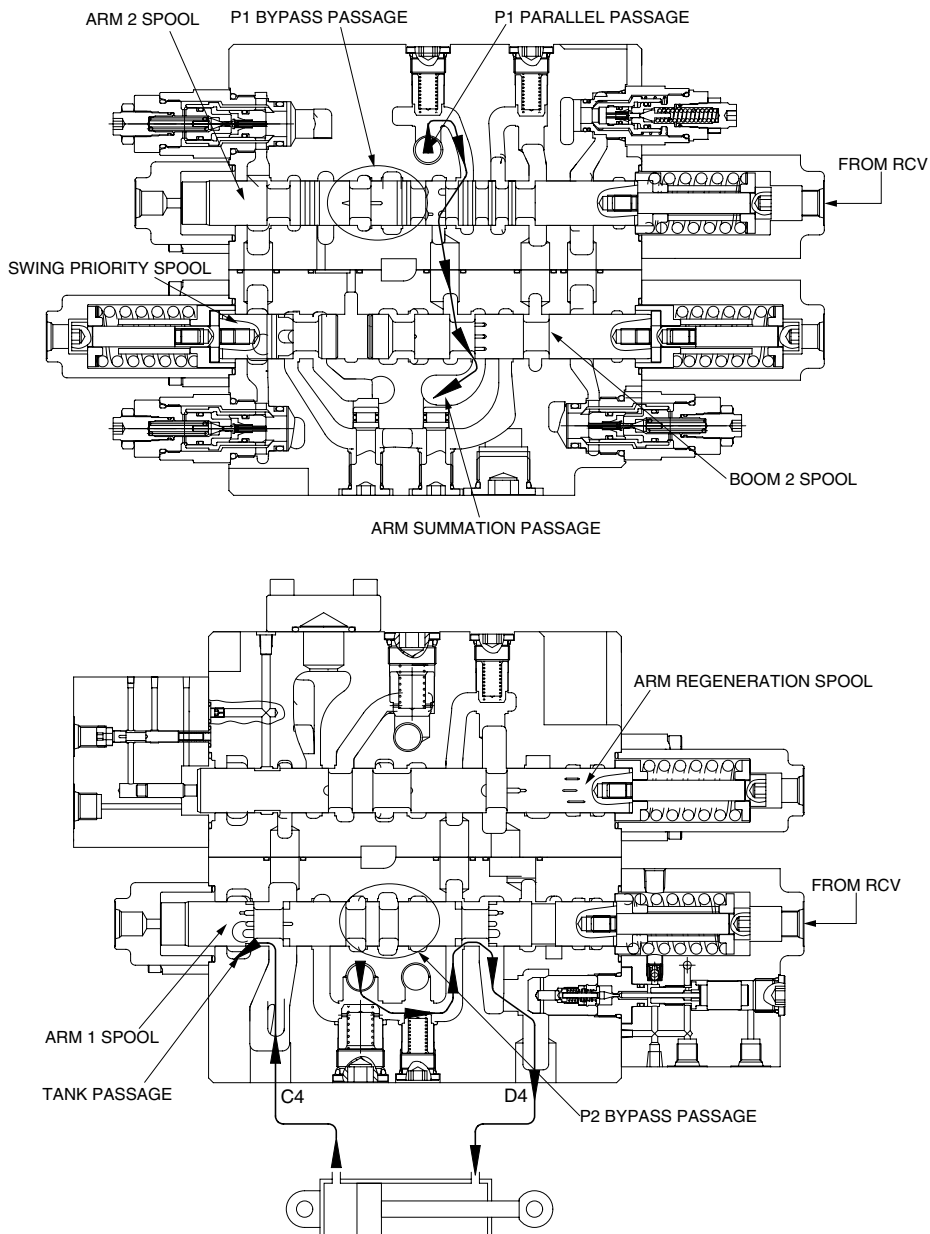

8) SWING PRIORITY FUNCTION

During swing priority operation, the pilot secondary pressure is supplied to the port of the spring side of the swing priority spool and shift swing priority spool in the right direction.

The hydraulic fluid from P2 parallel passage flows into the parallel passage of arm 1 side through swing priority spool and the passage "A" and also flows into the boom 2 spool.

When the swing priority spool is neutral condition, the passage is same as normal condition. But due to shifting of the swing priority spool, the fluid from pump P2 flows to swing side more then the boom 2, arm 1, option B and bucket summation spools to make the swing operation most preferential.

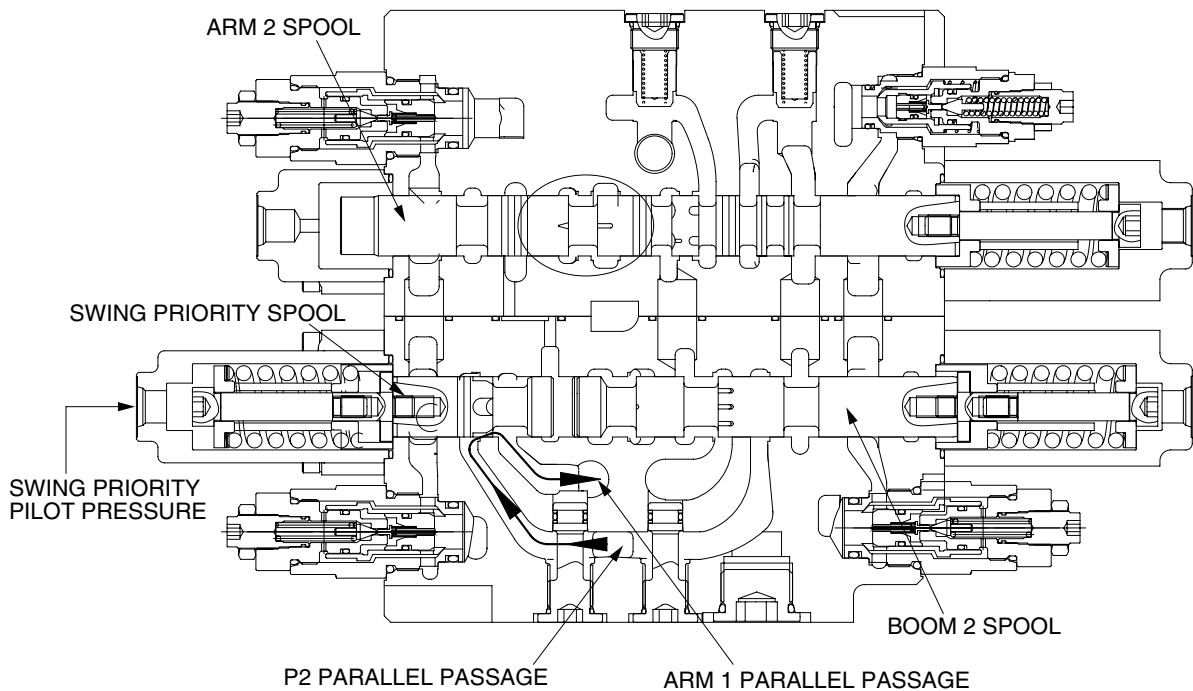

9) OPERATION OF OPTION

(1) OPERATION BY PUMP P2

The pilot secondary pressure from RCV is supplied to the port of spring side and shifts option spool as the figure.

The bypass passage is shut off by the movement of the spool and the hydraulic fluid from pump P2 flows into actuator through the load check valve, bridge passage and port D5.

If the pilot pressure is not supplied to P1 summation pilot port and is not shifts arm 2 spool. Accordingly, the pump P1 fluid connected the parallel passage is not flowing the check poppet of option ON/OFF valve and the fluid from pump is not joined the fluid from P2.

At the same time, the fluid from actuator returns to the tank passage through port C5 and notch of the option spool.

In case of reverse operation, the operating principle is same as above.

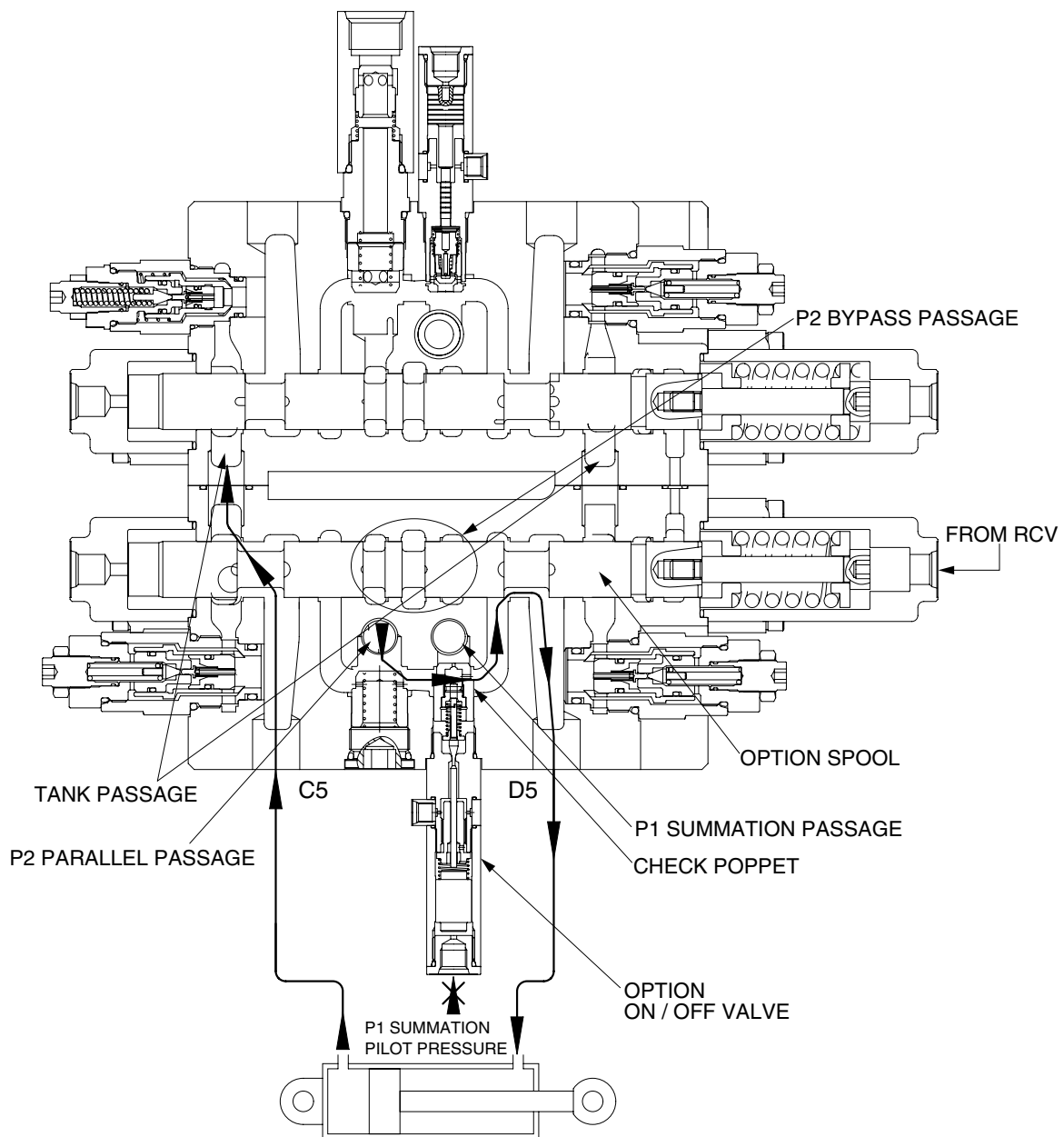

(2) SUMMATION OPERATION WITH PUMP P1

The pilot pressure from RCV is supplied to option pilot port and one of arm 2 pilot port at the same time, the fluid for the arm summation is build up. This fluid flows into the arm 1 spool priority but the arm is not operated, the fluid flows into P1 summation passage. Now the pilot pressure of RCV is supplied to the P1 summation pilot port of option ON/OFF valve, the fluid from pump P1 opens the load check valve and flows into port D5 with the fluid of pump P2.

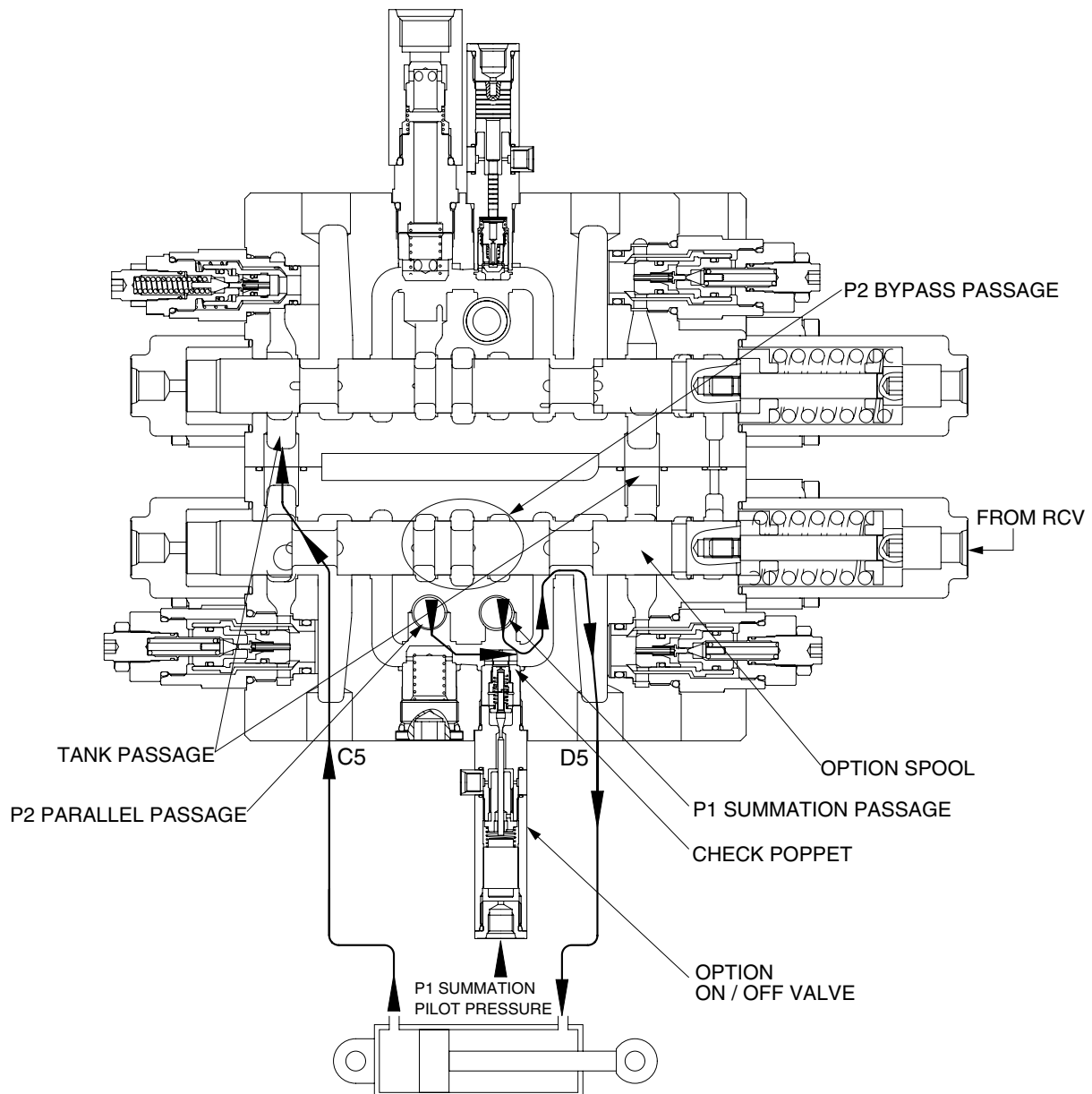

11) NEGATIVE RELIEF VALVE OPERATION

When no function is being actuated on P1 side, the hydraulic fluid from the pump P1, flows into the tank passage through the bypass passage and orifice. The restriction caused by this orifice thereby pressurizes. This pressure is transferred as the negative control signal pressure Pn1 to the pump P1 regulator.

It controls the pump regulator so as to minimize the discharge of the pump P1.

The bypass passage is shut off when the shifting of one or more spools and the flow through bypass passage became zero. The pressure of negative control signal becomes zero and the discharge of the pump P1 becomes maximum.

The negative control pressure reaches to the set level, the hydraulic fluid in the passage pushes open negative control valve and escapes into the return passage.

For the pump P2 the same negative control principle.

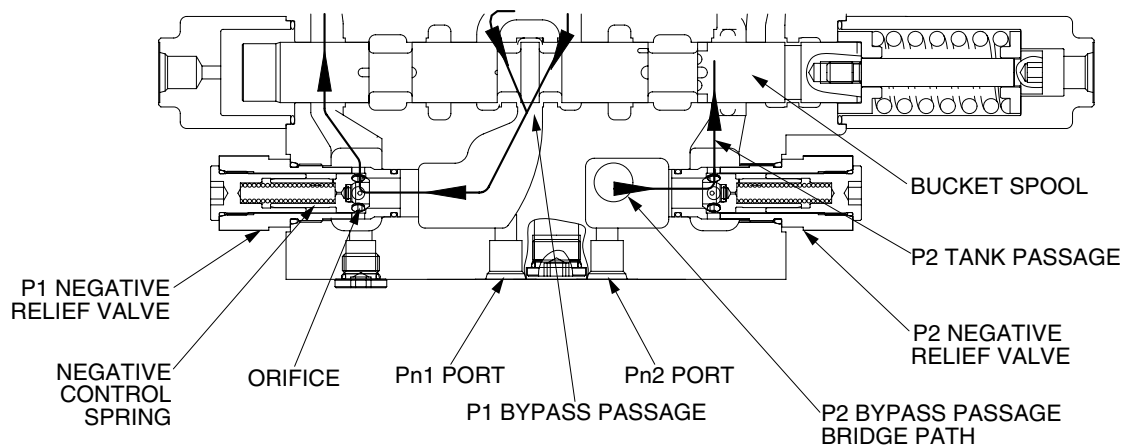

12) OPERATION OF MAIN RELIEF VALVE

- (1) The pressurized oil passes through the orifice (A) of the plunger is filled up in chamber A of the inside space, and seats the plunger against the housing securely.

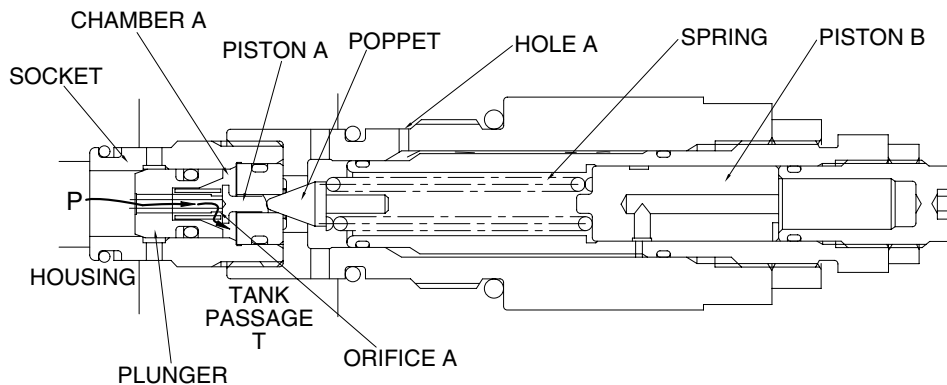

- (2) When the pressure at (P) becomes equal to the set pressure of the spring the hydraulic oil passes through the piston (A) pushes open the poppet and flows to tank passage (T) through the plunger internal passage, periphery orifice A, chamber A, periphery orifice B and the hole (E).

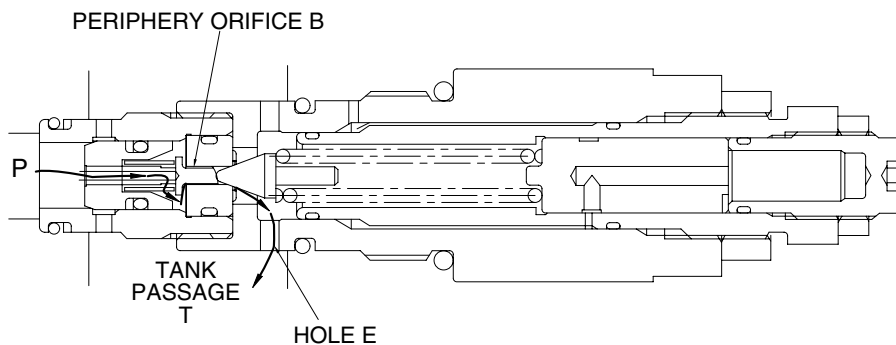

- (3) Opening the poppet causes the pressure in chamber A to fall and the plunger to open. As the result the pressurized oil at port P runs into tank passage (T).

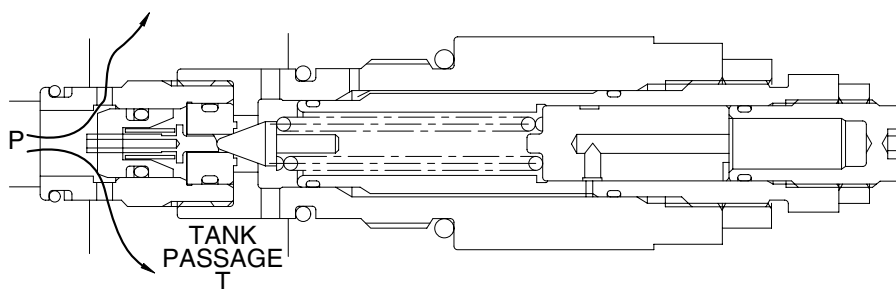

- (4) The pressure at port P becomes lower than set pressure of the spring, the poppet is seated by spring force. Then the pressure at port P becomes equal to set pressure of the spring and the plunger is seated to the socket.

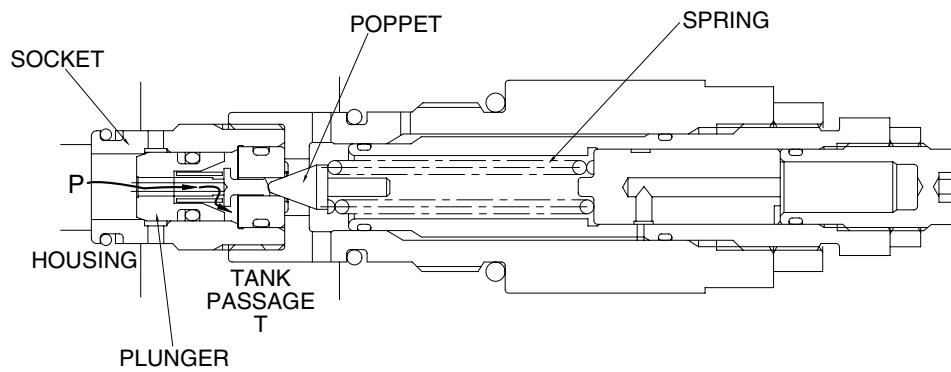

- (5) When the power boost switch is ON, the pilot pressure enters through hole A. It pushes the piston (B) in the left direction to increase the force of the spring and change the relief set pressure to the high pressure.

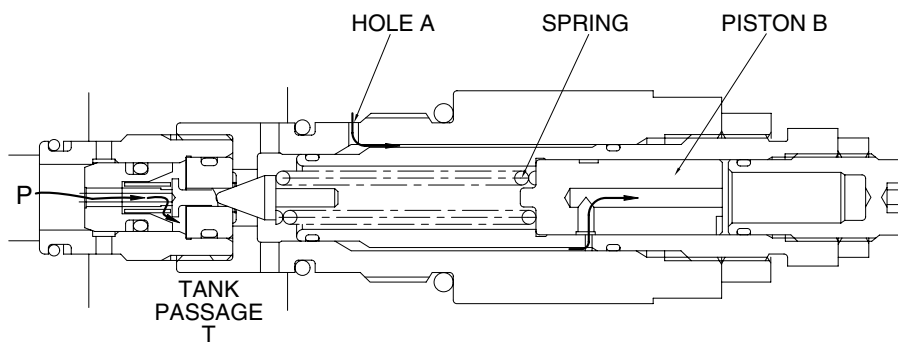

13) OPERATION OF OVERLOAD RELIEF VALVE

FUNCTION AS RELIEF VALVE

- (1) The pressurized oil passes through the piston and orifice A is filled up in chamber A of the inside space and seat the plunger against the socket and the socket against the housing securely.

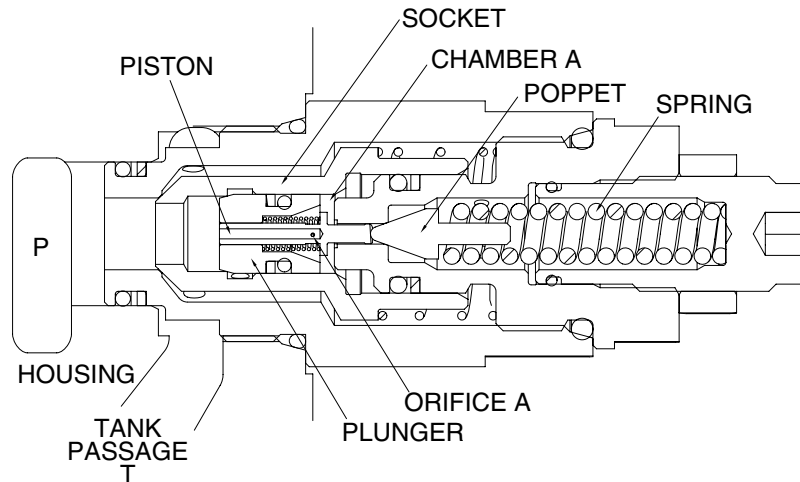

- (2) When the pressure at port P becomes equal to the set pressure of the spring, the pressurized oil pushes open the poppet and flows to tank passage (T) through the plunger internal passage, orifice A, chamber A, periphery orifice B and hole E.

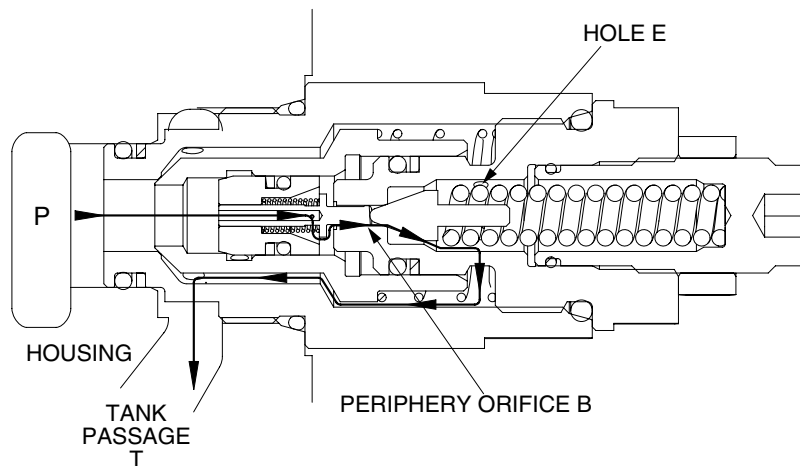

- (3) Opening of the poppet causes the pressure in chamber A to fall and the plunger to open. As the result the pressurized oil at port P runs into tank passage (T).

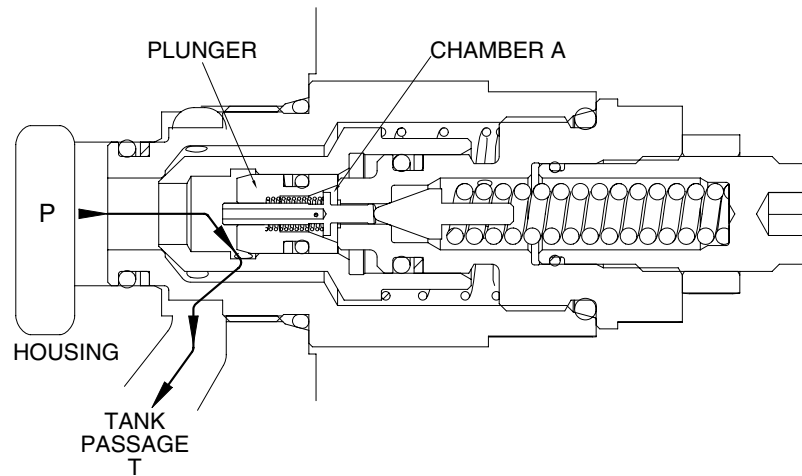

- (4) The pressure at port P becomes lower than set pressure of the spring, the poppet is seated by spring force. Then the pressure at port P becomes equal to set pressure of the spring and the plunger is seated to the socket.

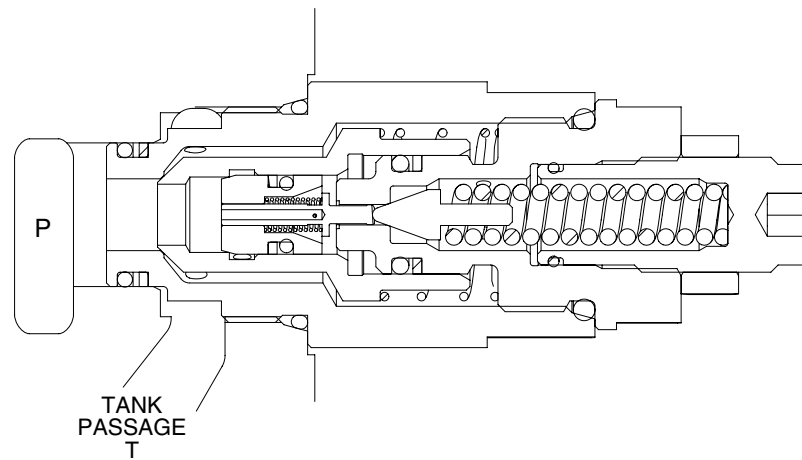

MAKE-UP FUNCTION

- (5) When negative pressure exists at port P, the oil is supplied through tank passage (T). When the pressure at tank passage (T) becomes higher than that of at port P, the socket moves in the right direction. Then, sufficient oil passes around the socket from tank passage (T) to port P and fills up the space.

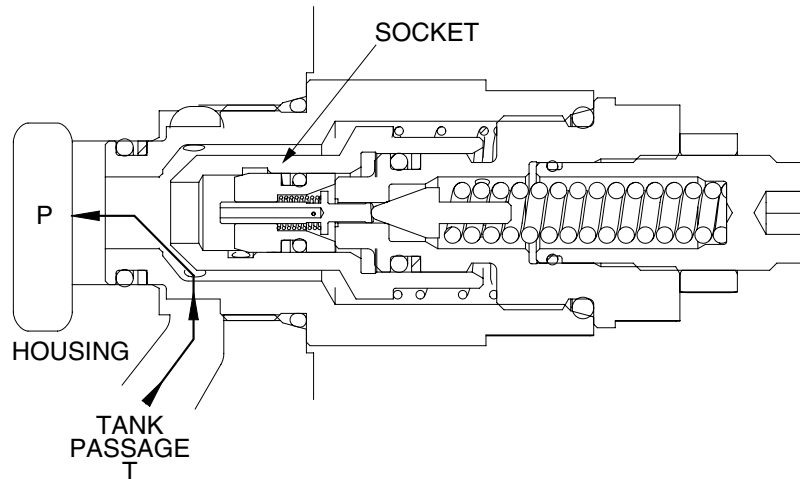

14) BREAKER OVERLOAD RELIEF VALVE FUNCTION

- (1) The structure and function of 2 stage relief valve is similar with the overload relief but it can set the higher pressure by pilot pressure.

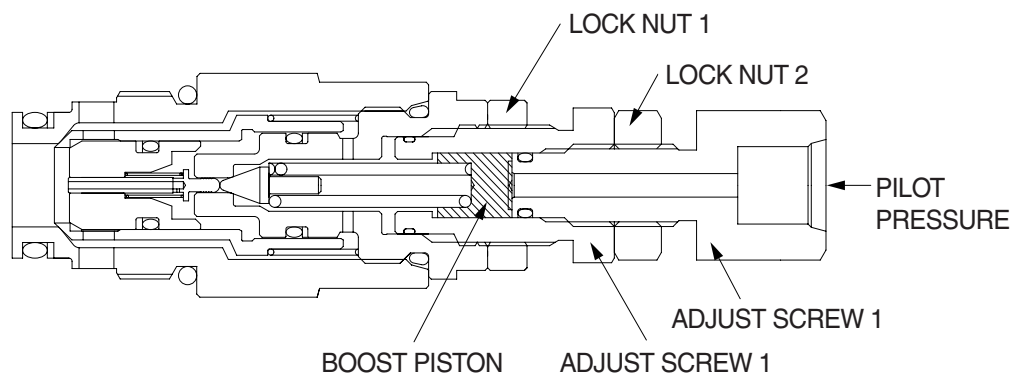

Boost function

- (1) When the pilot pressure is supplied, the spring is a little compressed by moving of the boost piston and the set pressure is higher as length of spring compressed.

Pressure set method

- (2) Loosen lock nut 1 and 2 and then full tighten adjust screw 2.
- (3) Set the high pressure by adjusting the adjust screw 1 and 2 and then fix it by the lock nut 1. Keep the adjust screw 1 do not move when fixing the lock nut 1.
- (4) Set the low pressure by adjusting the adjust screw 2 and then fix it by the lock nut 2. Keep the adjust screw 2 do not move when fixing the lock nut 2.

GROUP 3 SWING DEVICE

1. STRUCTURE

Swing device consists swing motor, swing reduction gear.

Swing motor include mechanical parking valve, relief valve, make up valve and time delay valve.

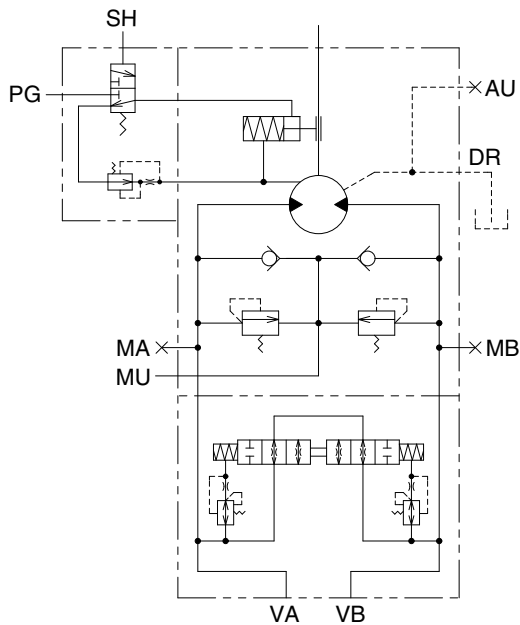
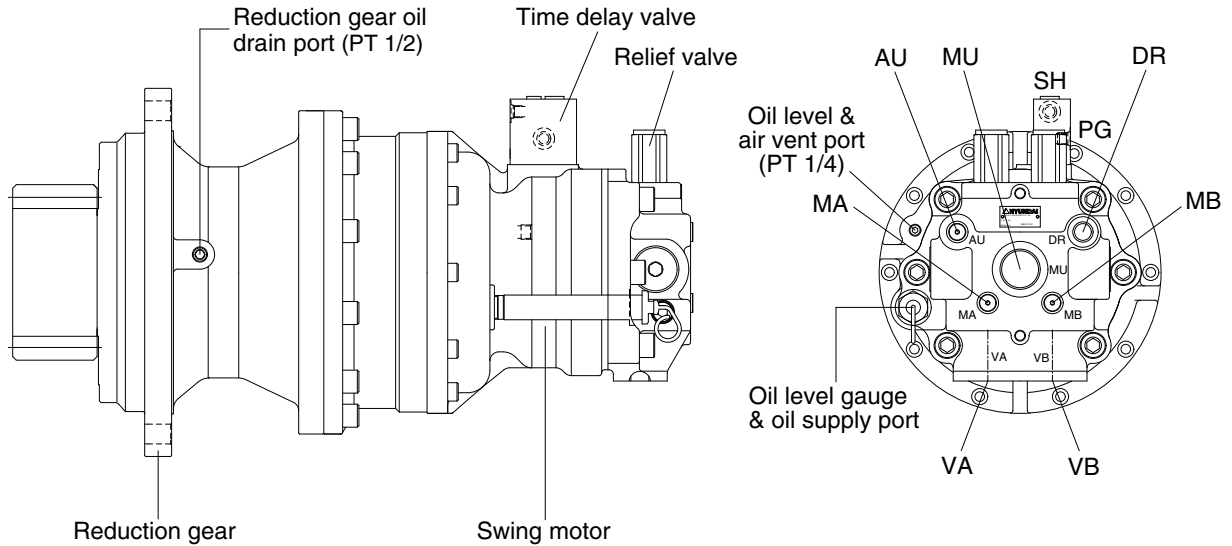

Hydraulic circuit

Port	Port name	Port size
VA	Main port	ø 20
VB	Main port	ø 20
DR	Drain port	PF 1/2
MU	Make up port	PF 1 1/4
PG	Brake release stand by port	PF 1/4
SH	Brake release pilot port	PF 1/4
MA, MB	Gauge port	PF 1/4
AU	Air vent port	PF 1/4

1) SWING MOTOR

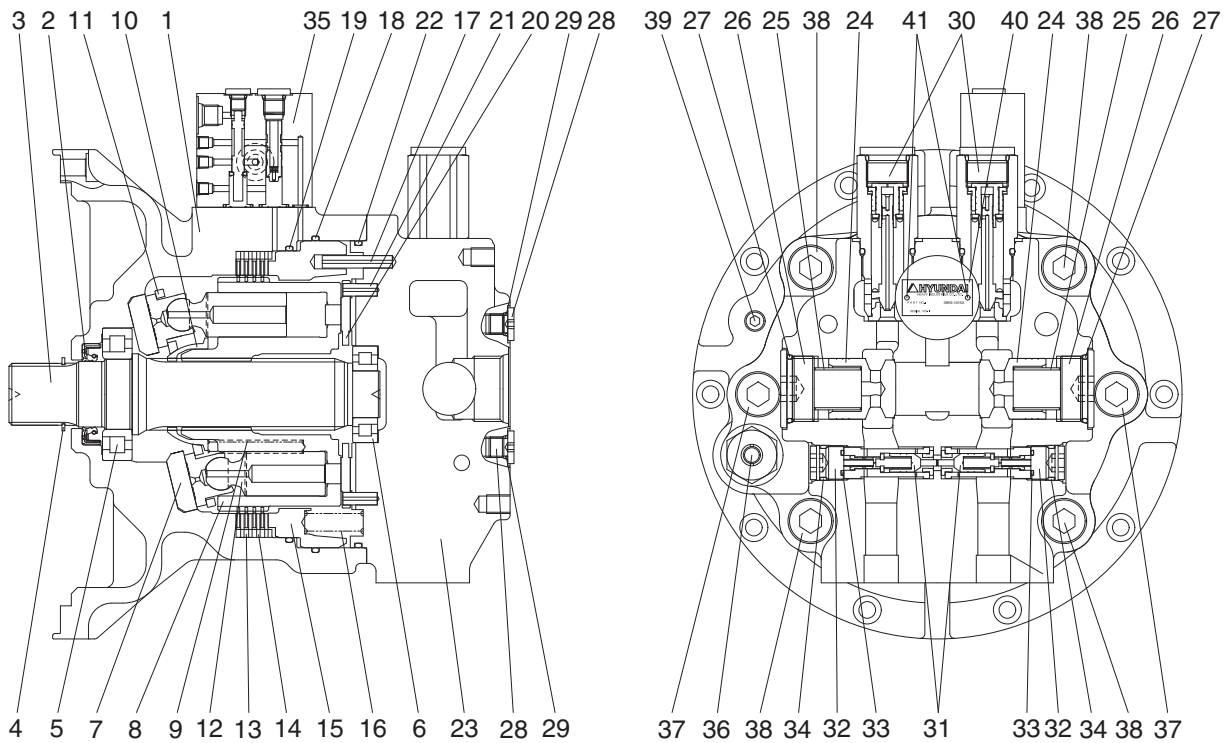

- | | | | | | |
|----|----------------|----|----------------|----|-------------------------|
| 1 | Casing | 15 | Parking piston | 29 | O-ring |
| 2 | Oil seal | 16 | Brake spring | 30 | Relief valve assy |
| 3 | Shaft | 17 | Spring pin | 31 | Reactionless valve assy |
| 4 | Snap ring | 18 | O-ring | 32 | Plug |
| 5 | Roller bearing | 19 | O-ring | 33 | O-ring |
| 6 | Needle bearing | 20 | Valve plate | 34 | O-ring |
| 7 | Swash plate | 21 | Spring pin | 35 | Time delay valve assy |
| 8 | Cylinder block | 22 | O-ring | 36 | Level gauge |
| 9 | Spring | 23 | Valve casing | 37 | Socket bolt |
| 10 | Ball guide | 24 | Check valve | 38 | Socket bolt |
| 11 | Retainer plate | 25 | Spring | 39 | Plug |
| 12 | Piston assy | 26 | Plug | 40 | Name plate |
| 13 | Friction plate | 27 | O-ring | 41 | Rivet |
| 14 | Separate plate | 28 | Plug | | |

2) REDUCTION GEAR

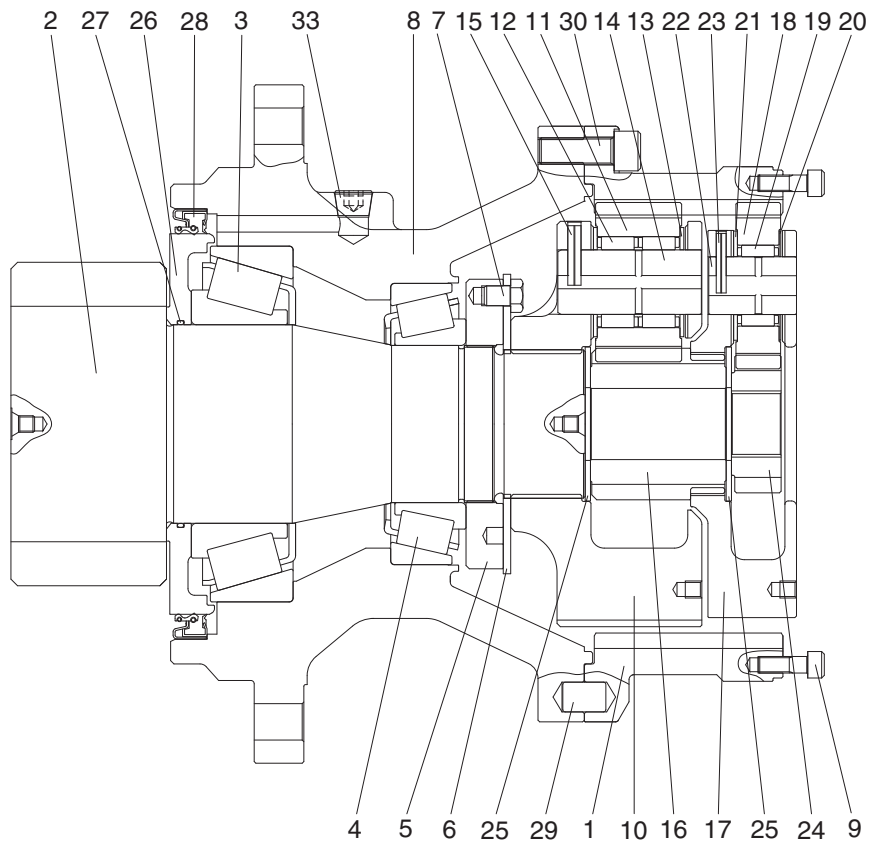

- | | | | | | |
|----|---------------|----|------------------|----|-----------------|
| 1 | Ring gear | 11 | Planetary gear 2 | 21 | Thrust washer 1 |
| 2 | Drive shaft | 12 | Needle bearing 2 | 22 | Carrier pin 1 |
| 3 | Taper bearing | 13 | Thrust washer 2 | 23 | Spring pin 1 |
| 4 | Taper bearing | 14 | Carrier pin 2 | 24 | Sun gear 1 |
| 5 | Ring nut | 15 | Spring pin 2 | 25 | Thrust plate |
| 6 | Lock plate | 16 | Sun gear 2 | 26 | Sleeve |
| 7 | Hexagon bolt | 17 | Carrier 1 | 27 | O-ring |
| 8 | Casing | 18 | Planetary gear 1 | 29 | Parallel pin |
| 9 | Socket bolt | 19 | Needle bearing 1 | 30 | Socket bolt |
| 10 | Carrier 2 | 20 | Thrust washer 1 | 33 | Plug |

2. PRINCIPLE OF DRIVING

2.1 Generating the turning force

The high hydraulic supplied from a hydraulic pump flows into a cylinder block (8) through valve casing of motor (23), and valve plate (20).

The high hydraulic is built as flowing on one side of Y-Y line connected by the upper and lower sides of piston (12).

The high hydraulic can generate the force, $F1 = P \times A$ (P : supplied pressure, A : water pressure area), like following pictures, working on a piston.

This force, $F1$, is divided as $N1$ thrust partial pressure and $W1$ radial partial pressure, in case of the plate of a tilt angle, α .

$W1$ generates torque, $T = W1 \times R1$, for Y-Y line connected by the upper and lower sides of the piston as following pictures.

The sum of torque ($\sum W1 \times R1$), generated from each piston (4~5 pieces) on the side of a high hydraulic, generates the turning force.

This torque transfers the turning force to a cylinder (8) through a piston; because a cylinder is combined with a turning axis and spline, a turning axis rotates and a turning force is sent.

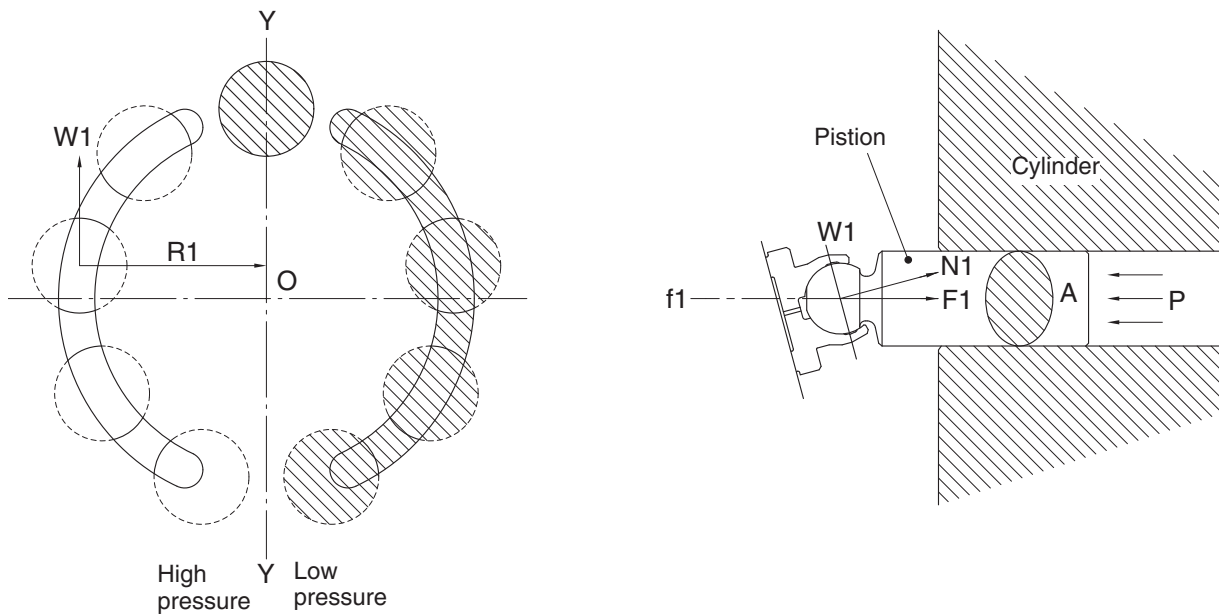

2) MAKE UP VALVE

In the system using this type of motor, there is no counter balance functioning valve and there happens the case of revolution exceeding hydraulic supply of motor. To prevent the cavitation caused by insufficient oil flow there is a make up valve to fill up the oil insufficiency.

A make up valve is provided immediately before the port leading to the hydraulic oil tank to secure feed pressure required when the hydraulic motor makes a pumping action. The boost pressure acts on the hydraulic motor's feed port via the make up valve.

Pressurized oil into the port B, the motor rotate counterclockwise.

If the plunger of MCV moves neutral position, the oil in the motor is drain via left relief valve, the drain oil run into motor via right make up valve, which prevent the cavitation of motor.

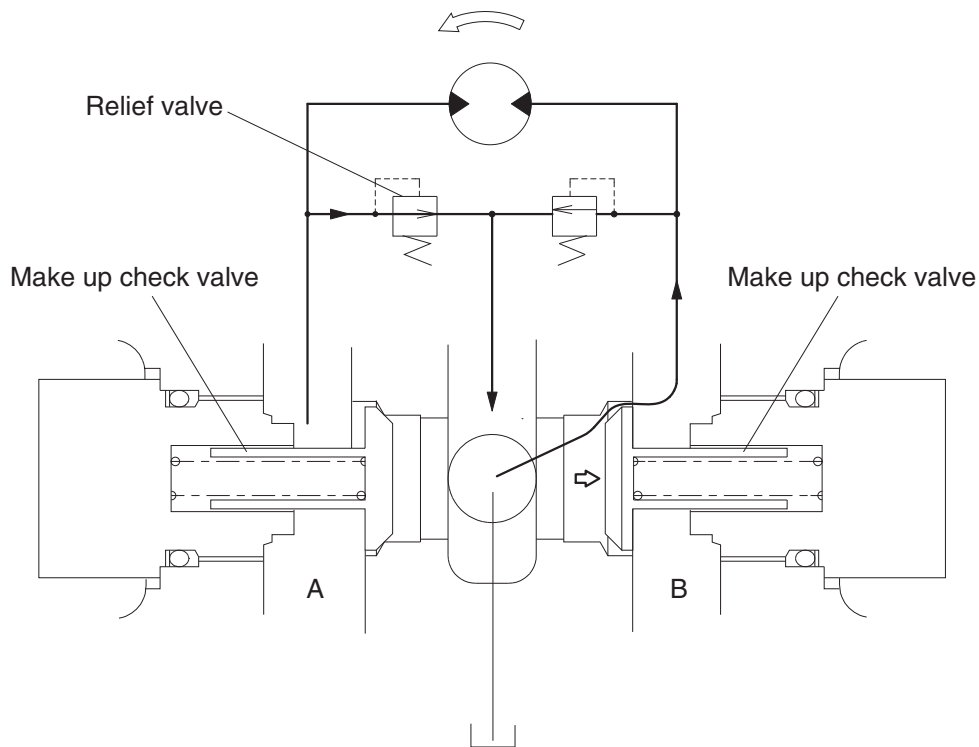

3) RELIEF VALVE

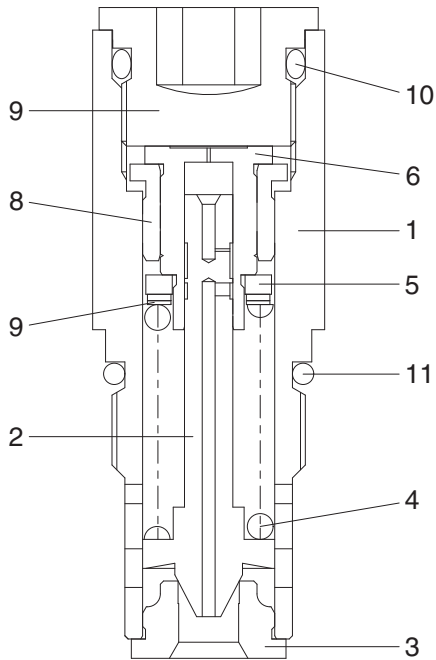

- 1 Sleeve
- 2 Poppet
- 3 Poppet seat
- 4 Spring
- 5 Spring seat
- 6 Shim
- 7 Piston
- 8 Stopper
- 9 Plug
- 10 O-ring
- 11 O-ring

(1) Construction of relief valve

The valve casing contains two cartridge type relief valves that stop the regular and reverse rotations of the hydraulic motor. The relief valves relieve high pressure at start or at stop of swing motion and can control the relief pressure in two steps, high and low, in order to insure smooth operation.

(2) Function of relief valve

Figure illustrates how the pressure acting on the relief valve is related to its rising process. Here is given the function, referring to the figure following page.

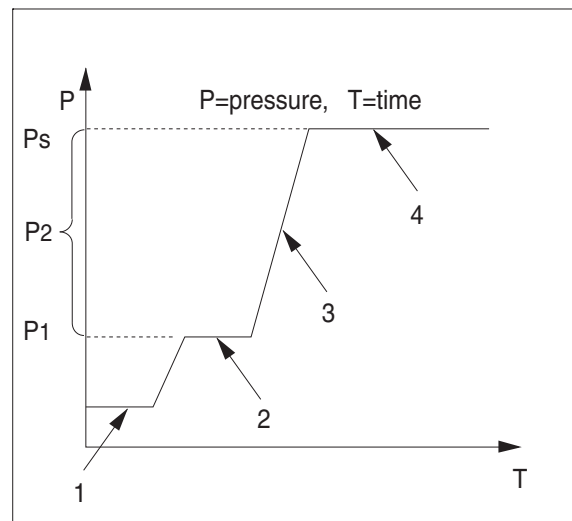

① Ports (P,R) at tank pressure.

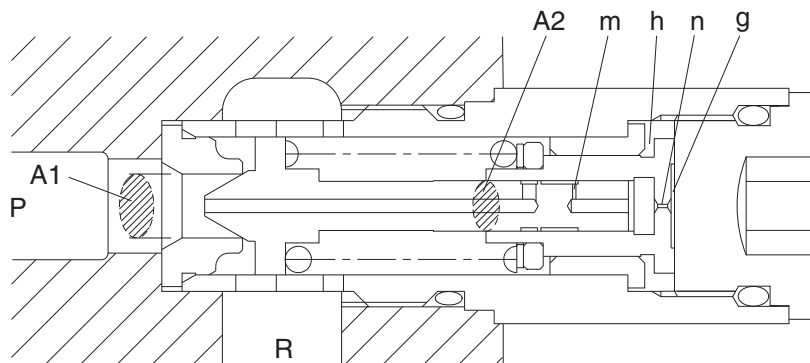

② When hydraulic oil pressure ($P \times A_1$) reaches the preset force (F_{SP}) of spring (4), the plunger (2) moves to the right as shown.

$$P_1 \times A_1 = F_{SP} + P_g \times A_2$$

$$P_1 = \frac{F_{SP} + P_g \times A_2}{A_1}$$

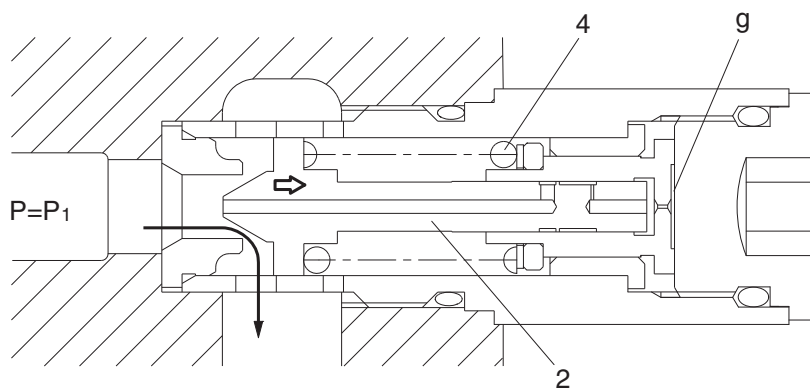

- ③ The oil flow chamber g via orifice m and n. When the pressure of chamber g reaches the preset force (F_{sp}) of spring (4), the piston (7) moves left and stop the piston (7) hits the bottom of bushing (8).

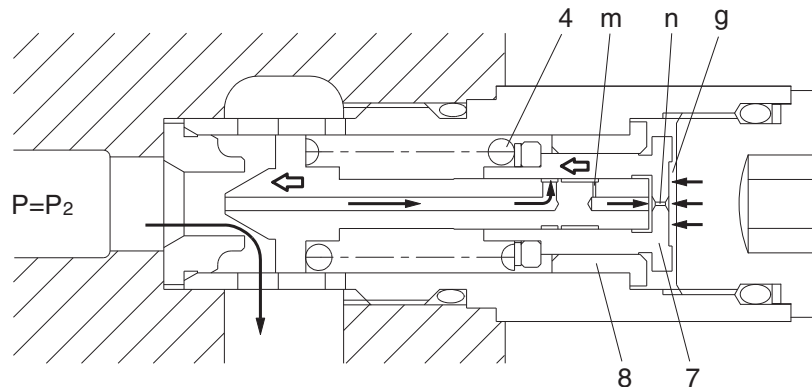

- ④ When piston (7) hits the bottom of bushing (8), it stops moving to the left any further. As the result, the pressure in chamber (g) equals (P_s).

$$P_s \times A_1 = F_{sp} + P_s \times A_2$$

$$P_s = \frac{F_{sp}}{A_1 - A_2}$$

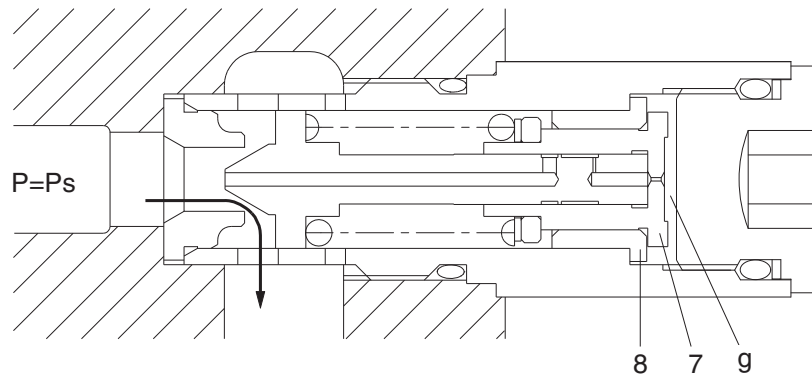

4) BRAKE SYSTEM

(1) Control valve swing brake system

This is the brake system to stop the swing motion of the excavator during operation.

In this system, the hydraulic circuit is throttled by the swing control valve, and the resistance created by this throttling works as a brake force to slow down the swing motion.

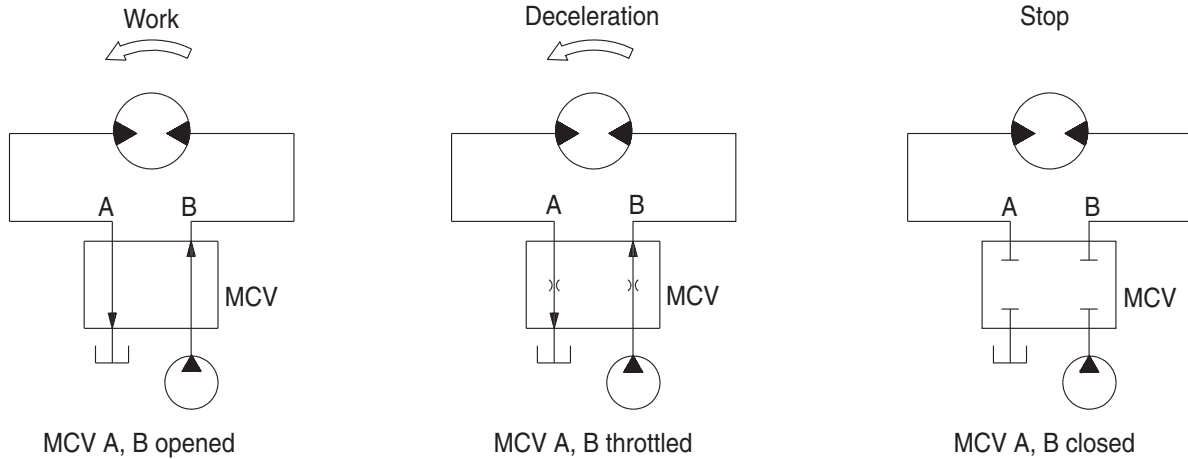

(2) Mechanical swing parking brake system

This is function as a parking brake only when all of the RCV lever (except swing, arm in) are not operated.

① Brake assembly

Circumferential rotation of separate plate (14) is constrained by the groove located at casing (1). When housing is pressed down by brake spring (16) through friction plate (13), separate plate (14) and parking piston (15), friction force occurs there.

Cylinder block (8) is constrained by this friction force and brake acts, while brake releases when hydraulic force exceeds spring force.

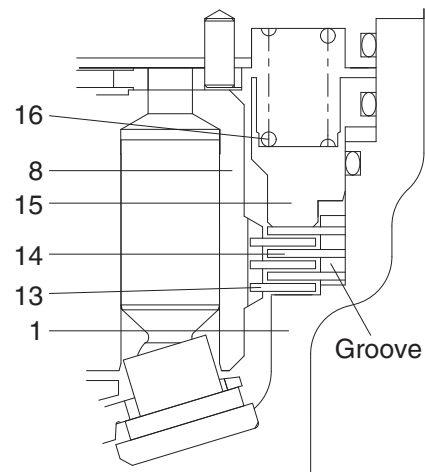

1	Casing	14	Separate plate
8	Cylinder block	15	Parking piston
13	Friction plate	16	Brake spring

② **Operating principle**

a. When the RCV lever (1) is set to the swing or arm in operating position, the pilot oil go to SH of the time delay valve (35).

This pressure moves spool (5) to the leftward against the force of the spring(8), so pilot pump charged oil (P3) goes to the chamber G through port PG.

This pressure is applied to move the parking piston (15) to the upward against the force of the brake spring (16). Thus, it releases the brake force.

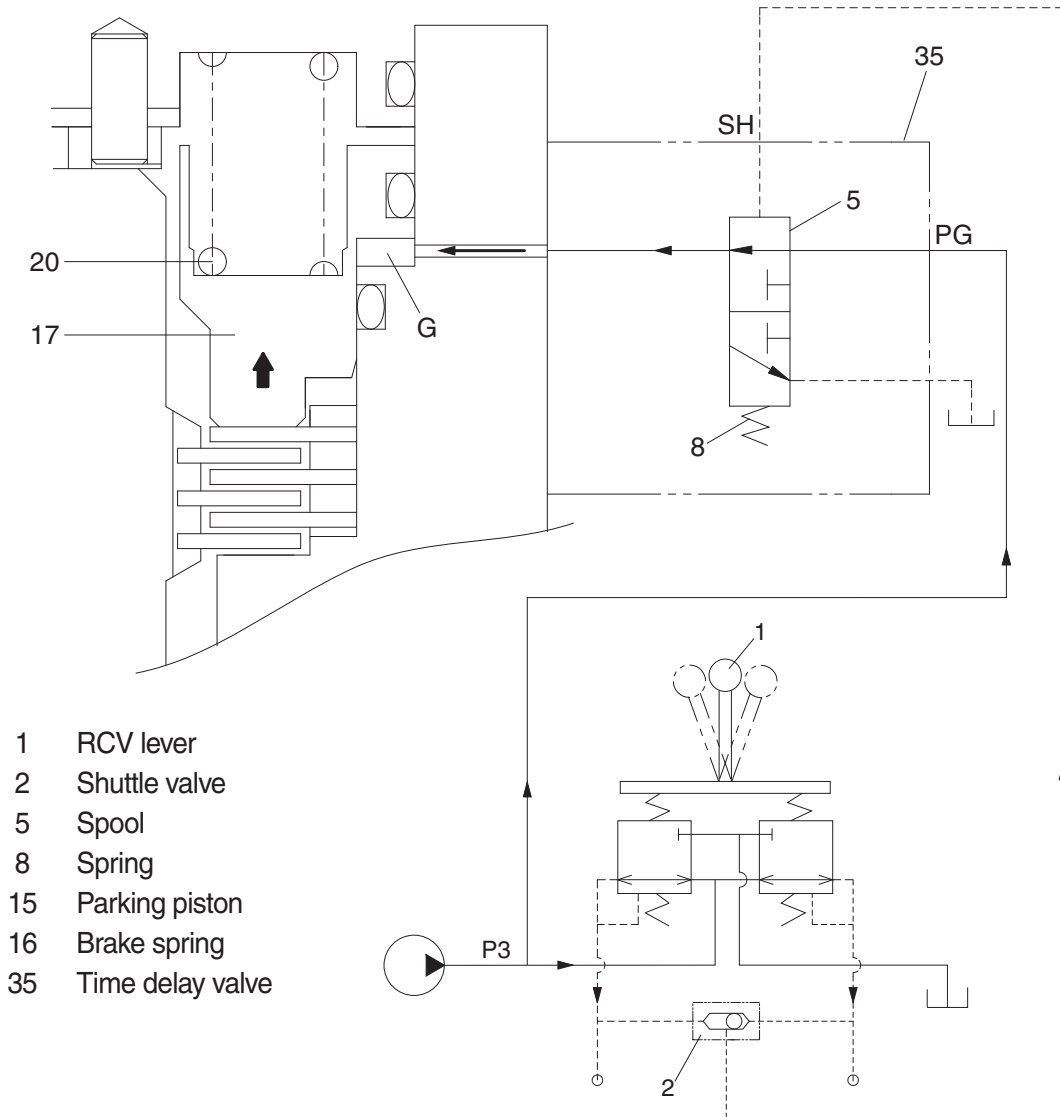

- b. When all of the RCV lever (1) are set the neutral position, the spool (5) returns to the top. Then, the parking piston (15) is moved lower by spring force and the return oil from the chamber G flows back to tank port. At this time, the brake works.

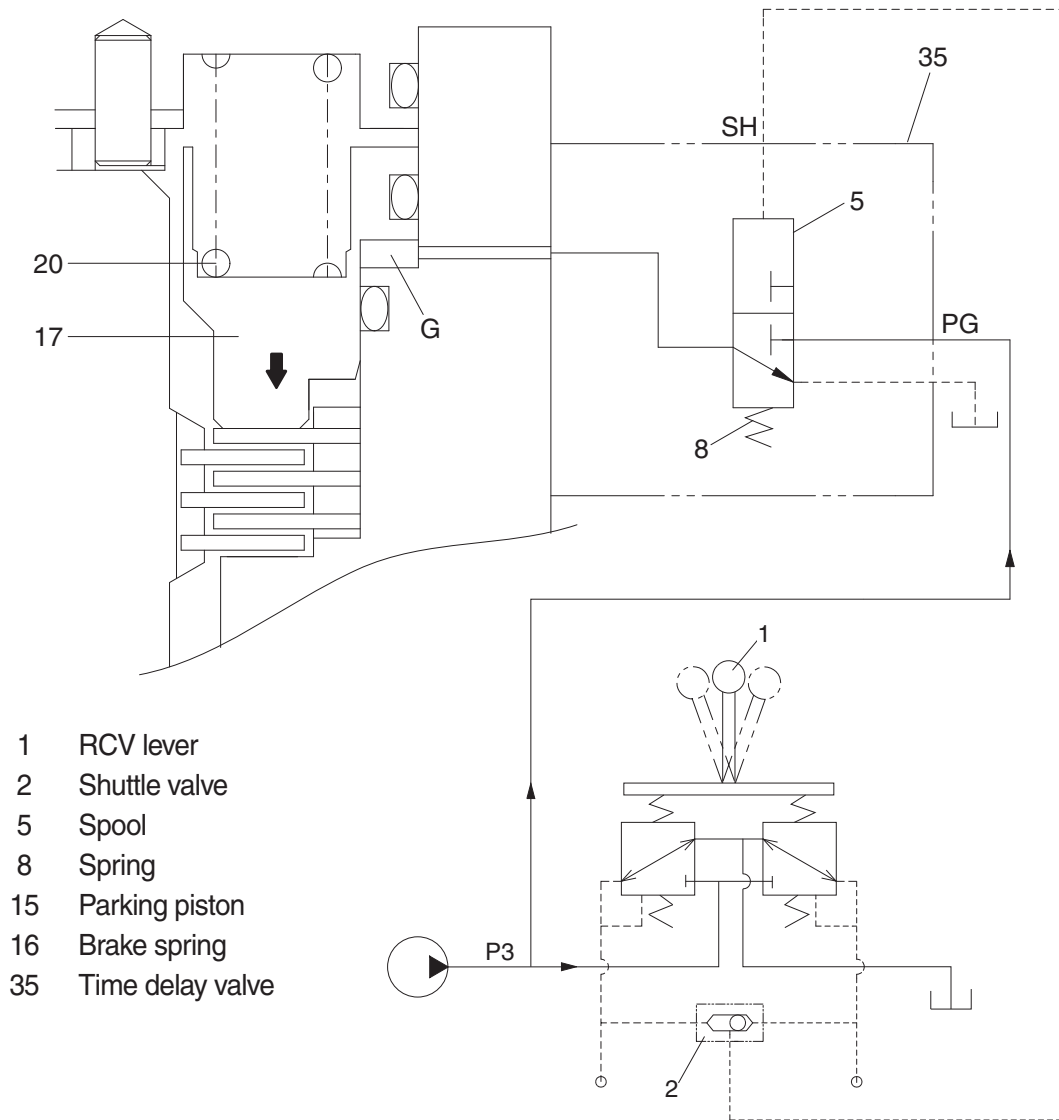

GROUP 4 TRAVEL DEVICE

1. CONSTRUCTION

Travel device consists travel motor and gear box.

Travel motor includes brake valve, parking brake and high/low speed changeover mechanism.

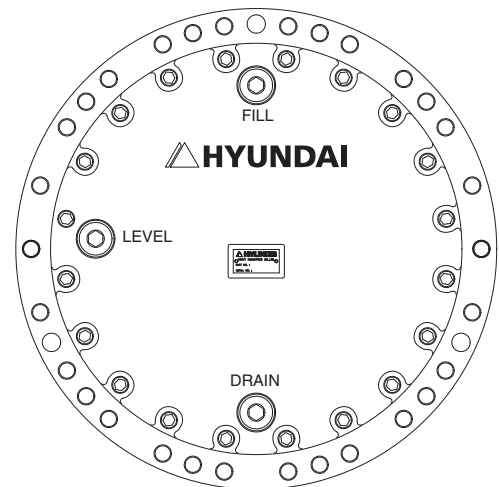
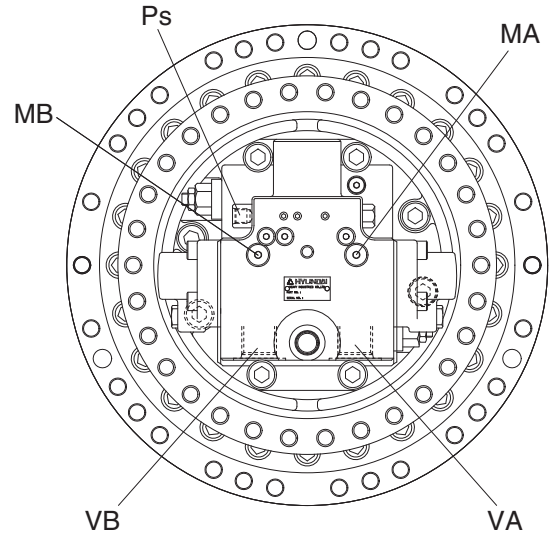
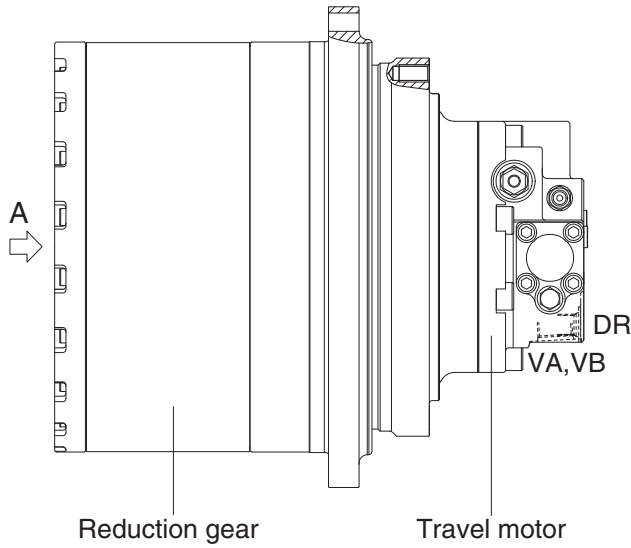

VIEW A

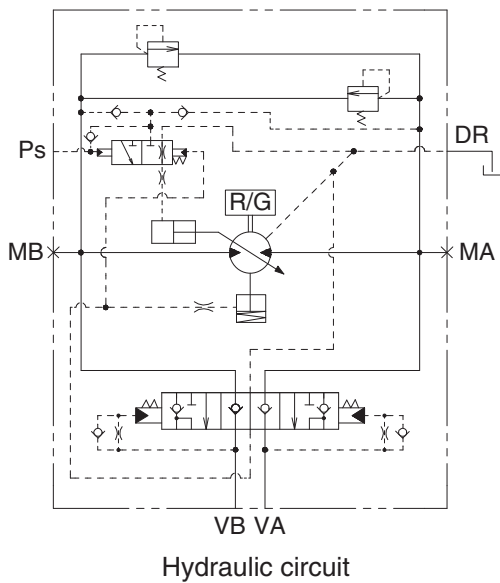

Port	Port name	Port size
VA, VB	Valve port	PF 1
Ps	Pilot port	PF 1/4
DR	Drain port	PF 1/2
MA, MB	Gauge port	PF 1/4

2. SPECIFICATION

1) TRAVEL MOTOR

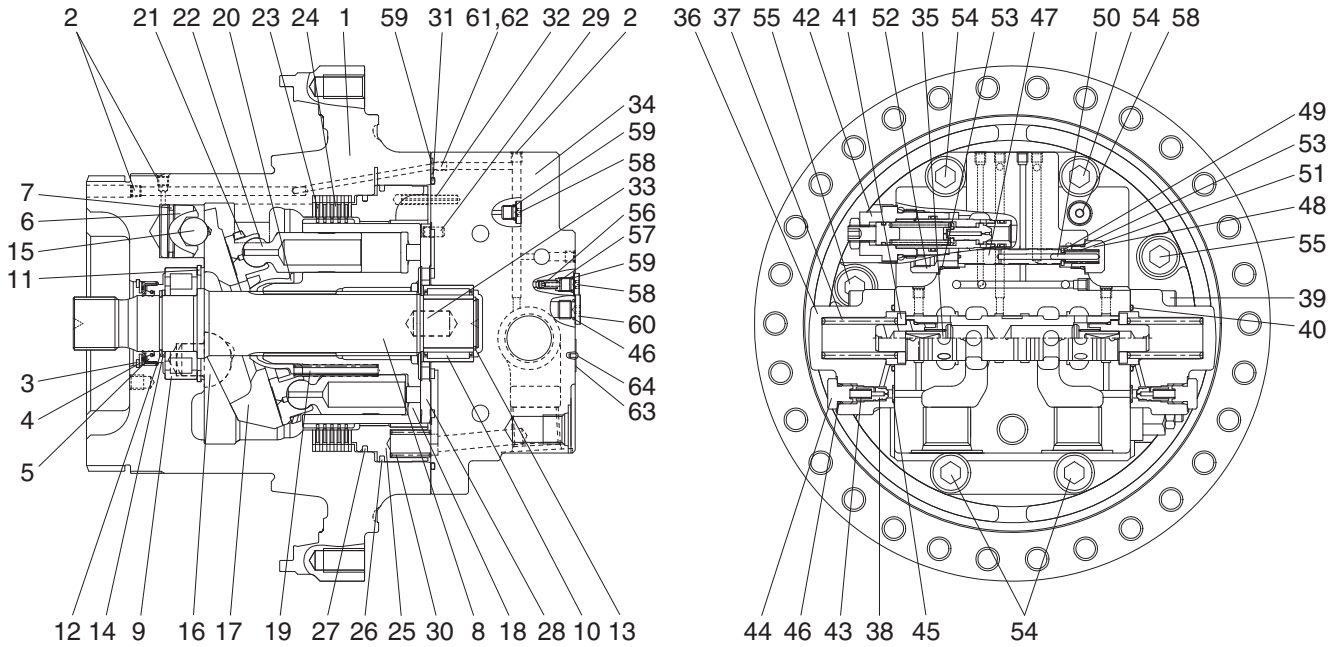

1	Casing	23	Friction plate	44	Plug
2	Plug	24	Separated plate	45	O-ring
3	Oil seal	25	Parking piston	46	O-ring
4	Thrust plate	26	D-ring	47	Spool
5	Snap ring	27	D-ring	48	Plug
6	Swash piston	28	Valve plate	49	Spring seat
7	Piston seal	29	Parallel pin	50	Parallel pin
8	Shaft	30	Brake spring	51	Spring
9	Cylinder roller bearing	31	O-ring	52	Connector
10	Needle bearing	32	Spring pin	53	O-ring
11	Snap ring	33	Parallel pin	54	Hexagon socket head bolt
12	Snap ring	34	Rear cover	55	Hexagon socket head bolt
13	Snap ring	35	Main spool assy	56	Check valve
14	Thrust plate	36	Spool cover	57	Spring
15	Steel ball	37	Spring	58	Plug
16	Pivot	38	Restrictor	59	O-ring
17	Swash plate	39	Hexagon socket head bolt	60	Plug
18	Cylinder block	40	O-ring	61	Restrictor
19	Spring	41	Spring seat	62	Restrictor
20	Ball guide	42	Relief valve assy	63	Name plate
21	Retainer plate	43	Spring	64	Rivet
22	Piston assy				

2) TRAVEL REDUCTION GEAR

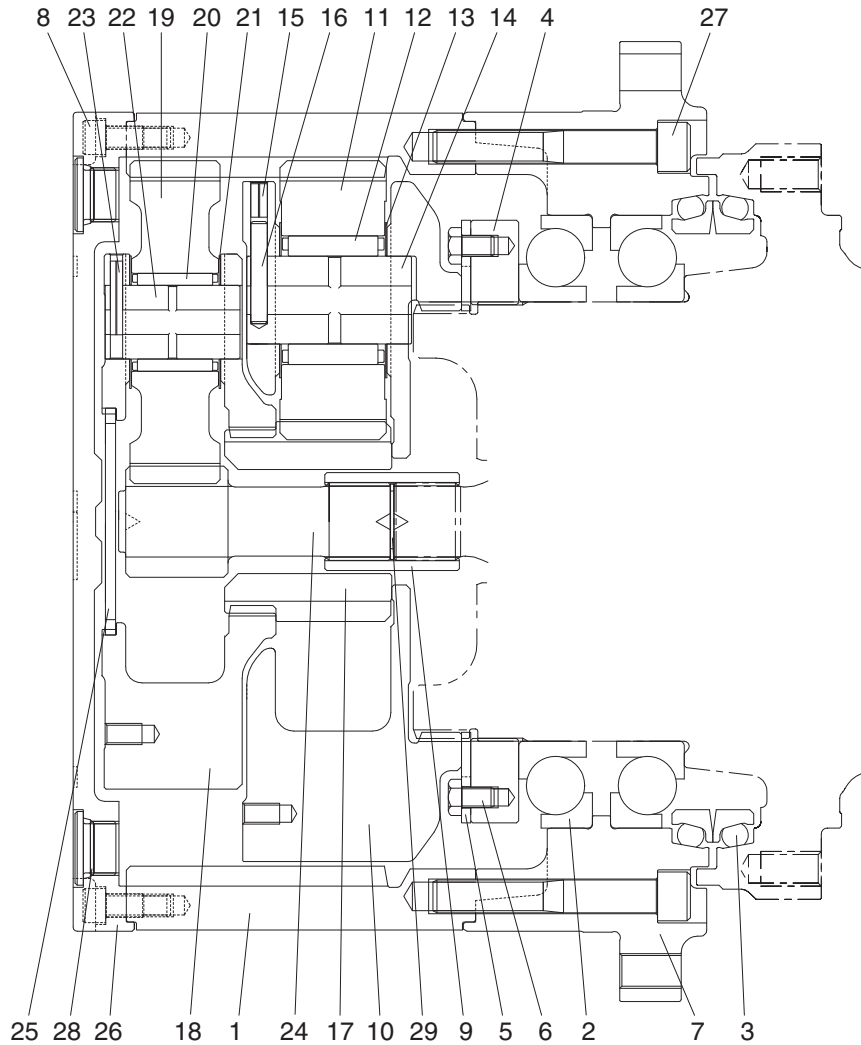

- | | | | | | |
|----|--------------------------|----|------------------|----|--------------------------|
| 1 | Ring gear | 12 | Needle bearing 2 | 22 | Carrier pin 1 |
| 2 | Ball bearing | 13 | Thrust washer 2 | 23 | Spring pin 1 |
| 3 | Floating seal assy | 14 | Carrier pin 2 | 24 | Sun gear 1 |
| 4 | Nut ring | 15 | Spring pin 2 | 25 | Thrust plate |
| 5 | Lock plate | 16 | Solid pin 2 | 26 | Cover |
| 6 | Hexagon bolt | 17 | Sun gear 2 | 27 | Hexagon socket head bolt |
| 7 | Housing | 18 | Carrier 1 | 28 | Plug |
| 8 | Hexagon socket head bolt | 19 | Planetary gear 1 | 29 | Snap ring |
| 9 | Coupling | 20 | Needle bearing 1 | 30 | Name plate |
| 10 | Carrier 2 | 21 | Thrust washer 1 | 31 | Rivet |
| 11 | Planetary gear 2 | | | | |

3. OPERATION

1) MOTOR

High pressure oil delivered from hydraulic pump is led to inlet port that is provided in the brake valve portion and, through the rear cover (34) and valve plate (28), led to cylinder block (18).

The oil flow and direction of shaft rotation are indicated in table.

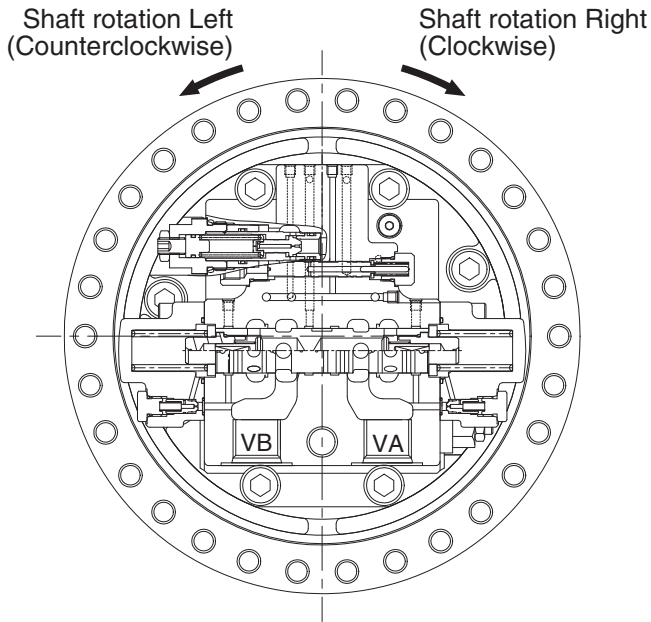

Inlet port	Outlet port	Direction of shaft rotation (viewing from rear cover)
VB	VA	Right (clockwise)
VA	VB	Left (counterclockwise)

As shown in below figure, high pressure oil is supplied to the pistons which are on one side of the line Y-Y that connects upper and lower dead points and produces force F1.

$$F1 = P \times A \quad (P : \text{pressure}, A : \text{area of piston section})$$

The swash plate (17) with inclined angle of α divides this force F1 into thrust force F2 and radial force F31-34.

This radial force is applied to axis Y-Y as turning force and generate drive torque of T.

$$T = r_1 \cdot F31 + r_2 \cdot F32 + r_3 \cdot F33 + r_4 \cdot F34$$

This drive torque is transmitted via cylinder block (18) to driving shaft (8).

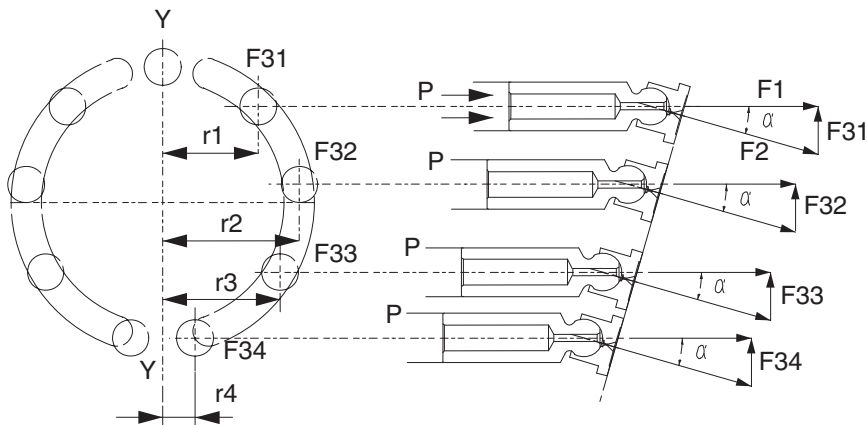

2) PARKING BRAKE

Parking brake is released when high pressure oil selected by the brake valve portion that is connected directly to the rear cover (34), is applied to the parking piston (25).

Otherwise the braking torque is always applied.

This braking torque is generated by the friction between the separated plates (24), inserted into the casing (1), and friction plates (23), coupled to cylinder block (18) by the outer splines.

When no pressure is activated on the parking piston (25), it is pushed by the brake springs (30) and it pushes friction plates (23) and separated plates (24) towards casing (1) and generates the friction force which brakes the rotation of cylinder block (18) and hence the shaft (8).

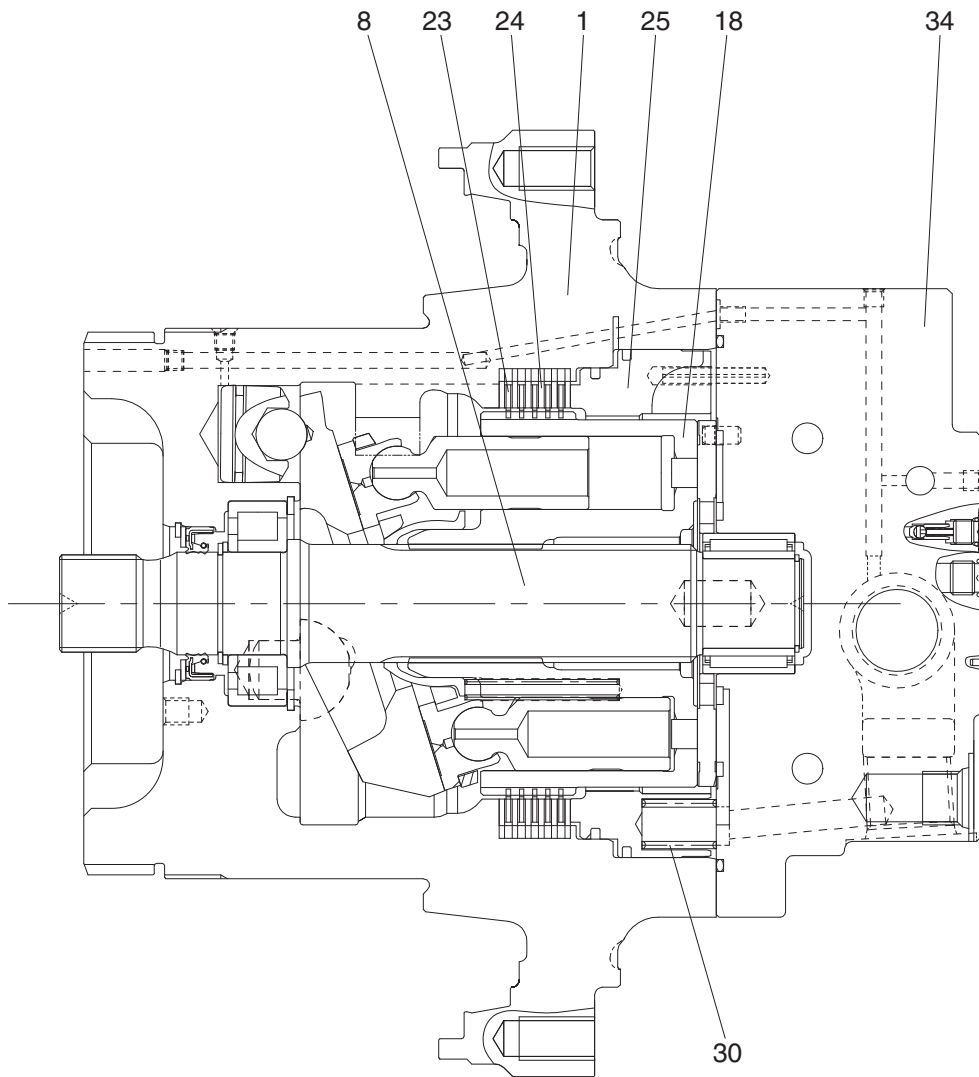

3) CAPACITY CONTROL MECHANISM

Figure typically shows the capacity control mechanism.

When high speed pilot line is charged with the pressure P_A that overcome the spring (51), the spring (51) is compressed and spool (47) shifts to the right to connect the port P and port C.

Then, the highest pressure is selected by the check valve (56) from inlet and outlet pressure of the motor and high speed pilot line pressure and pushes shifter piston (6). As a result, swash plate (17) turns around the line L which connect the two pivots (16) as shown by dotted lines. The turn stops at the stopper (1-1) of casing and swash plate (17) keeps the position.

In this case, the piston stroke become shorter and motor capacity become smaller and motor rotates faster, around 1.60 times, by the same volume of oil.

When no pressure is in the high speed pilot line P_A , spool (35) is pushed back by the spring (51) and pressure that pressed the shifter piston (6) is released to the hydraulic tank through restrictor (61).

Here, nine pistons are there and they equally spaced on the swash plate (17). The force that summed up those of pistons comes to almost the center of the swash plate (17) as shown. Since the pivots (16) are off-set by S from the center, the rotating force of product S and the force moves swash plate (17) to the former position and the speed returns to low.

When the power demand exceeds the engine power, such as in steep slope climbing or turning at high speed mode, the system step down to the low speed automatically. The mechanism is that: pump pressure is led to the port P_B and this pressure activate on pin (50). When the pressure at P_B exceeds predetermined value, spool (47) returns to the left by the counter-pressure against pin (50) and the pressure on the shifter piston (6) through port C is released to the tank and the motor comes to low speed.

When P_B goes down, the spool (47) moves to the right and the speed become high.

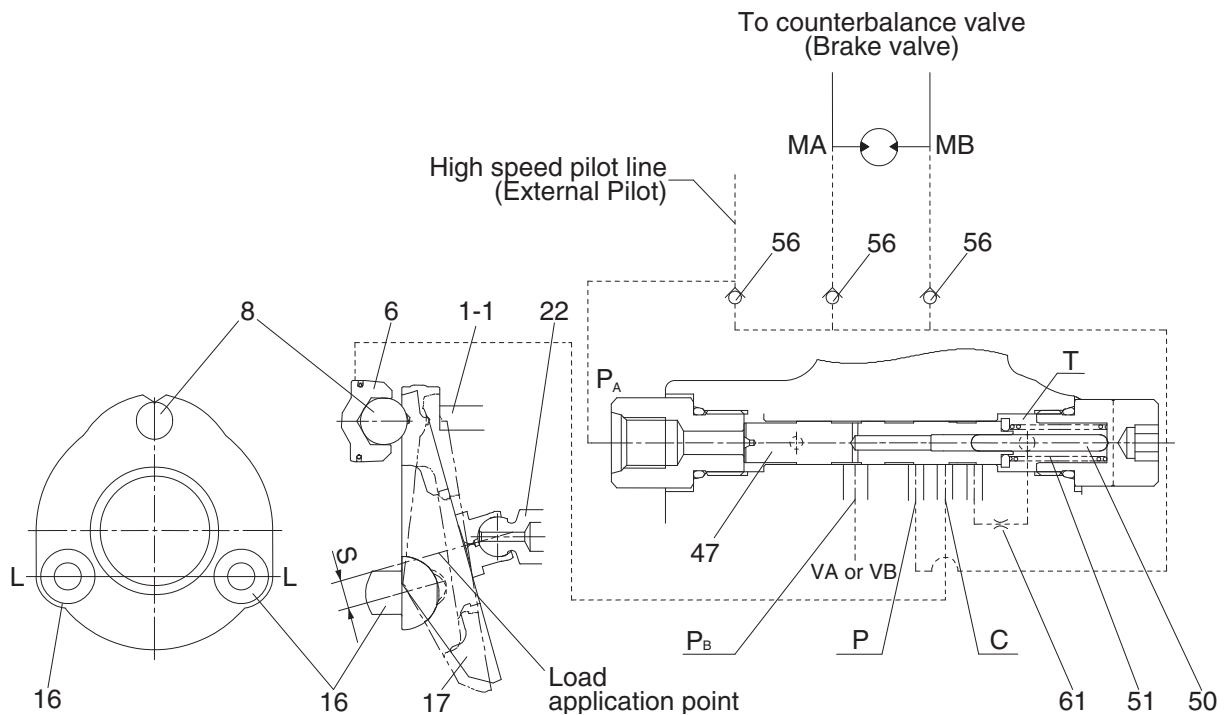

4) OVERLOAD RELIEF VALVE

(1) Structure

This valve is screwed in the motor rear cover (34) and consists of : plug (42-1) that is screwed and fixed in the rear cover (34), poppet (42-10) and supports the poppet seat (42-11), spring (42-4) that is operating relief valve setting pressure and supports the spring seat (42-5), that is inserted in the sleeve (42-6), screw (42-14) that is adjust the spring force, nut (42-15) that fix screw (42-14), piston (42-7) that reduce the shock.

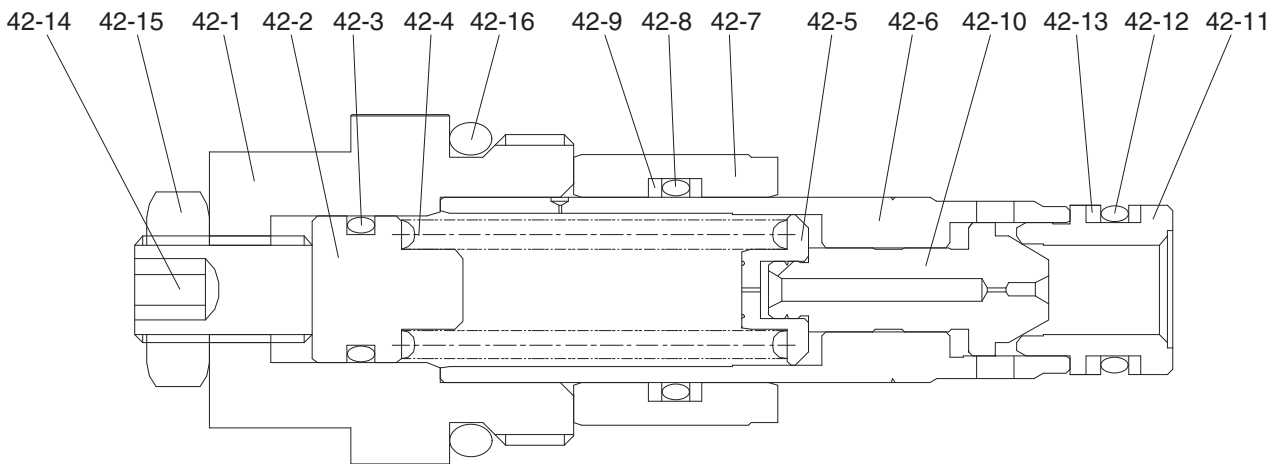

42-1 Plug
42-2 Guide
42-3 O-ring
42-4 Spring
42-5 Spring seat
42-6 Sleeve

42-7 Piston
42-8 O-ring
42-9 Back-up ring
42-10 Poppet
42-11 Poppet seat

42-12 O-ring
42-13 Back-up ring
42-14 Socket screw
42-15 Hexagon nut
42-16 O-ring

(2) Operation

Two pieces of overload valves are located at cross-over position in the counterbalance circuit of brake valve and have the following functions :

- ① When hydraulic motor starts, keep the driving pressure below predetermined value and while accelerating, bypasses surplus oil to return line.
- ② When stopping the motor, keep the brake pressure, that develops on the outlet side of motor, under the predetermined value to stop the inertial force.
- ③ To accelerate sharply while starting, and to mitigate the braking shock while stopping. For these purposes, the developed pressure is kept comparatively low for a short period, then keep the line pressure as normal value. While the pressure is low, meshing of reduction gears, crawler and sprocket etc. can be smoothly done and the shock are absorbed.

When starting, "A" port pressure of overload valve increases, this pressure is applied to the effective diameter of poppet (42-10) which seats on the poppet seat (42-11) and, at the same time, is delivered, via small hole, to the spring seat (42-5) located inside the sleeve (42-6) and the seat bore pressure increases up to "A" port pressure. The poppet (42-10) opposes to spring (42-4) by the force of the pressure exerted on the area difference between poppet seat's effective diameter and spring seat bore and keep the predetermined pressure.

When hydraulically braking, the piston (42-7) is at the left position by the driving pressure, and when "A" port pressure increases, the pressure is applied also to the piston (42-7) through the small hole in the poppet (42-10) and piston (42-7) moves rightward until it touches the stopper in rear cover. In this while, the poppet (42-10) maintains "A" port pressure at comparatively low against the spring (42-4) force and exhaust oil to "B" port side. After the piston reached to the plug, the valve acts the same as at starting.

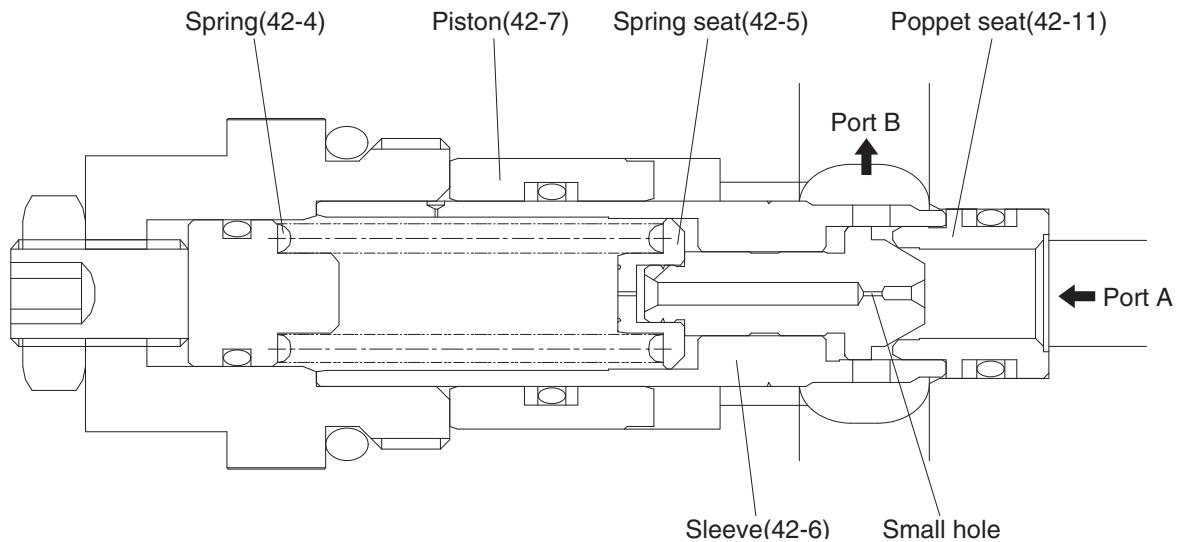

5) BRAKE VALVE

(1) Structure

The brake valve portion mainly consists of the following parts:

① Spool

By shifting the spool (35), the discharged oil from hydraulic motor is automatically shut off or restricted according to the condition and give the effect of holding, accelerating, stopping and counterbalance operations.

(See page 2-74, (2) Operation)

② Check valve (built in the spool)

This valve is located in the oil supplying passage to hydraulic motor, and at the same time functions to lock oil displacement. Therefore, this valve serves as not only a suction valve but also a holding valve for hydraulic motor.

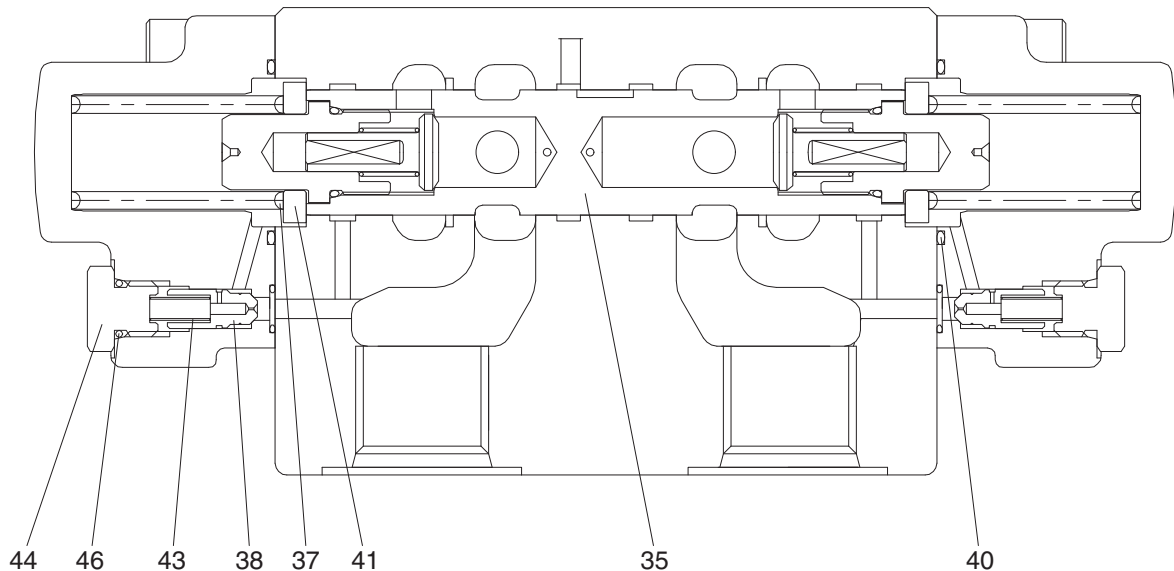

35 Main spool
37 Spring
38 Restrictor

40 O-ring
41 Spring seat
43 Restrictor spring

44 Plug
46 O-ring

(2) Operation

① Holding operation

When the control valve is at neutral position, VA and VB ports are connected to the tank, and the spring (37) located on both spool ends holds the spool (35) at central position.

Therefore, the passages from VA to MA and VB to MB are closed, which result in closing MA and MB ports connected to hydraulic motor.

Since the passage to parking brake is connected to the tank line, the brake cylinder pressure is equal to the tank pressure and the brake is applied by the springs. Thus, the rotation of the motor is mechanically prevented.

If external torque is exerted on the motor shaft, the motor would not rotate as usual by this negative parking brake.

In case the brake should be released for some reason, pressure is built on MA or MB port. But, due to oil leakage inside hydraulic motor or so, high-pressure oil escapes from the closed circuit and motor rotates a bit. So, the cavitation tends to occur in the lower pressure side of the closed circuit. Then, the check valve, built in the spool (35), operates to avoid the cavitation and opens the passage from VA to MA or from VB to MB. Then the oil equivalent to the leakage is sucked from the tank line to the closed circuit.

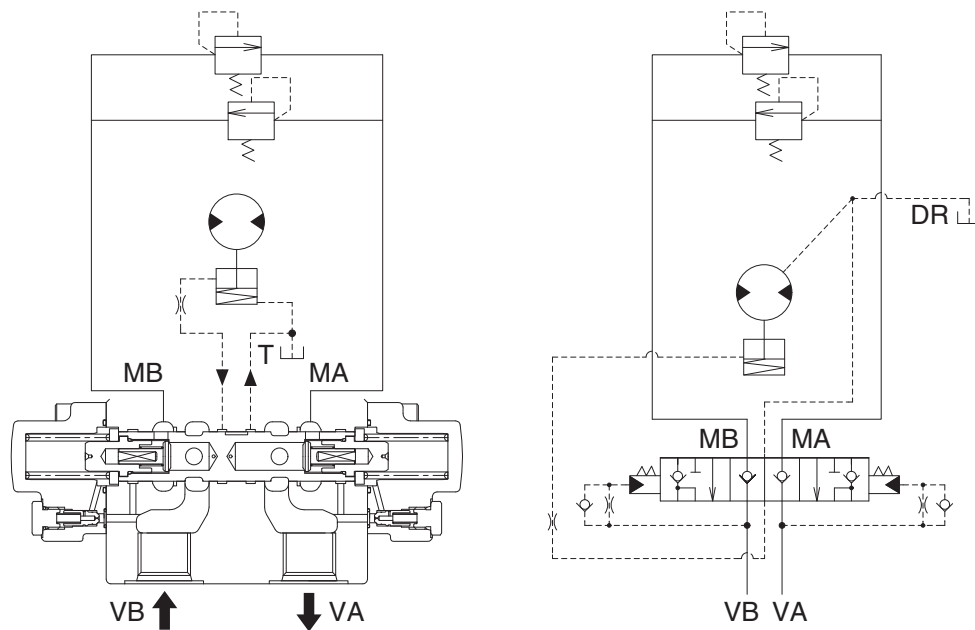

② Accelerating operation

When VA and VB ports are connected respectively to pump and tank by operating the control valve, hydraulic oil from pump is forwarded through VA port to push open the check valve provided inside spool (35), and oil flows to motor via MA port to rotate the motor.

Therefore, the pressure increases and negative brake is released by the pressure supplied from pump. At the same time, the pressure of pilot chamber increases to push and move the spool (35) leftwards, overcoming the spring (37) force. Thus, the return line from MB to VB opens to rotate the motor.

In case inertia load is too big to start rotation, accelerating pressure reaches the set pressure of relief valve and high pressure oil is being relieved while the motor gains the rotational speed.

As the rotational speed goes up, the relieved volume decreases, and finally the motor rotates at a fixed speed.

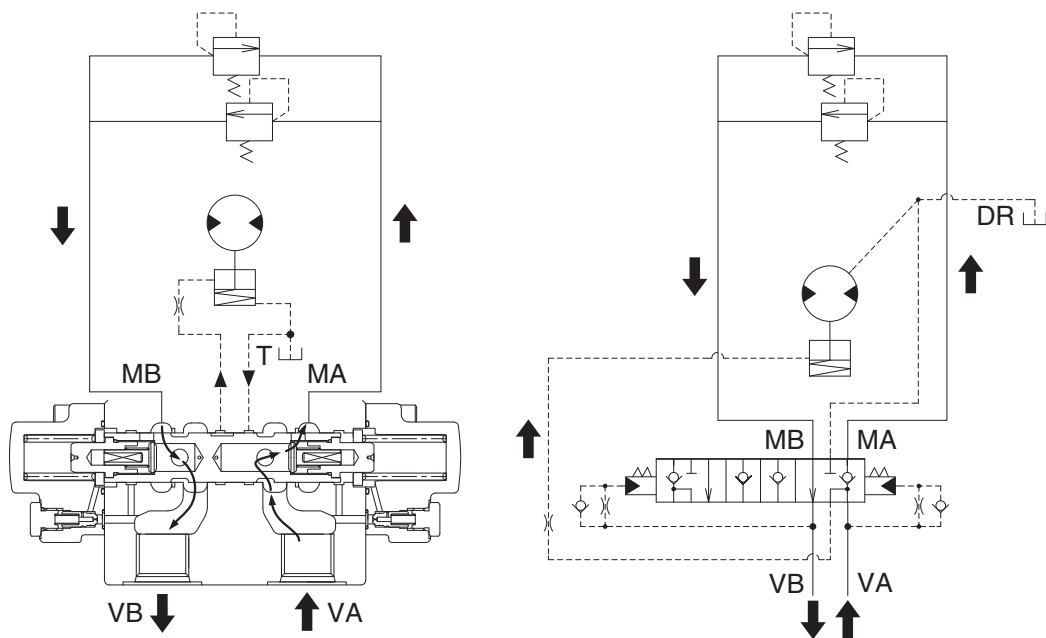

③ Stopping operation

Returning the control valve to neutral position while running the motor, the oil supply is cut off and VA and VB ports are connected to the tank line. Then the pressure of the pilot chamber located on both spool ends become equal, and the spool (35) returns to the neutral position by spring (37) force. Thus, the passage from MA to VA is closed.

Owing to the inertia force of the load, the hydraulic motor tends to continue the rotation. Here, the motor functions as a pump and forwards the oil to MB port but the passage is blocked and MB port pressure increases. Then the relief valve opens to relieve the pressure and rotational speed decelerates and at last the motor stops.

Negative brake release pressure is gradually lowered due to the restrictor and finally the brake works and the motor is mechanically stopped.

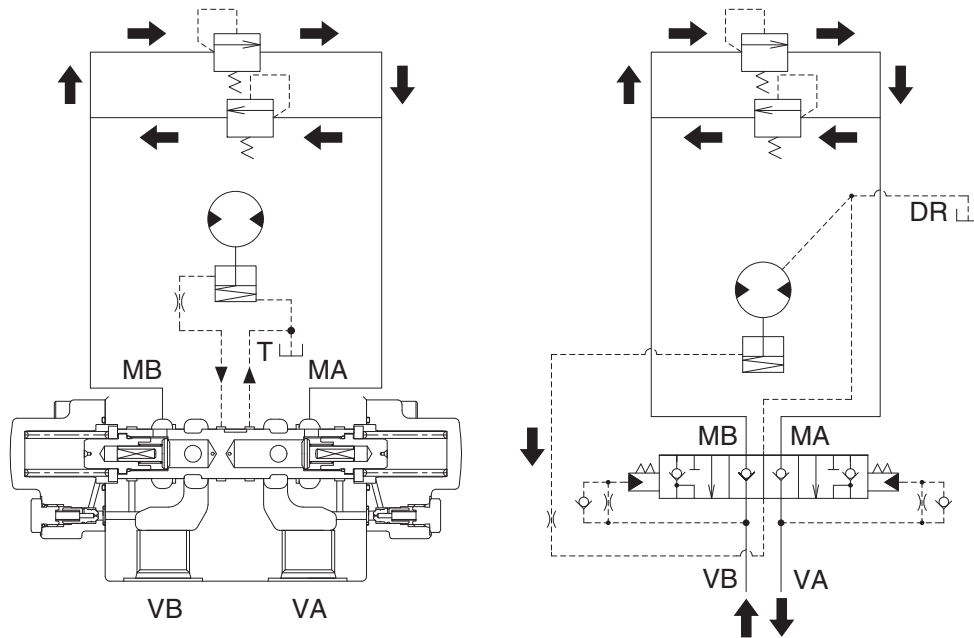

④ Counterbalance operation

Counterbalance operation is required to decelerate slowly the hydraulic motor while absorbing inertia force.

In case the hydraulic oil is gradually decreased from pump to VB port, the drive shaft of hydraulic motor tends to rotate faster than that matched to the volume of oil supply.

Consequently, the pilot chamber pressure on MB to VB side decreases and the spring (37) force moves the spool (35) leftwards towards neutral position.

Therefore, the area of passage from MA to VA becomes smaller and the pressure on MA side rises due to increased resistance in the passage and the motor receives hydraulic braking effect.

If the motor rotates slower than that matched to the volume of supplied oil, the pilot chamber pressure on VB port increases, and spool (35) moves rightwards to enlarge the area of passage from MA to VA. Therefore the braking effect becomes smaller and the rotational speed of motor is controlled to correspond to the volume of supplied oil.

In order to give stable counterbalance operation, the restrictors (38) are set in the pilot chamber to damp the spool (35) movement.

The parking brake is released during pressure adjusting action of the spool (35).

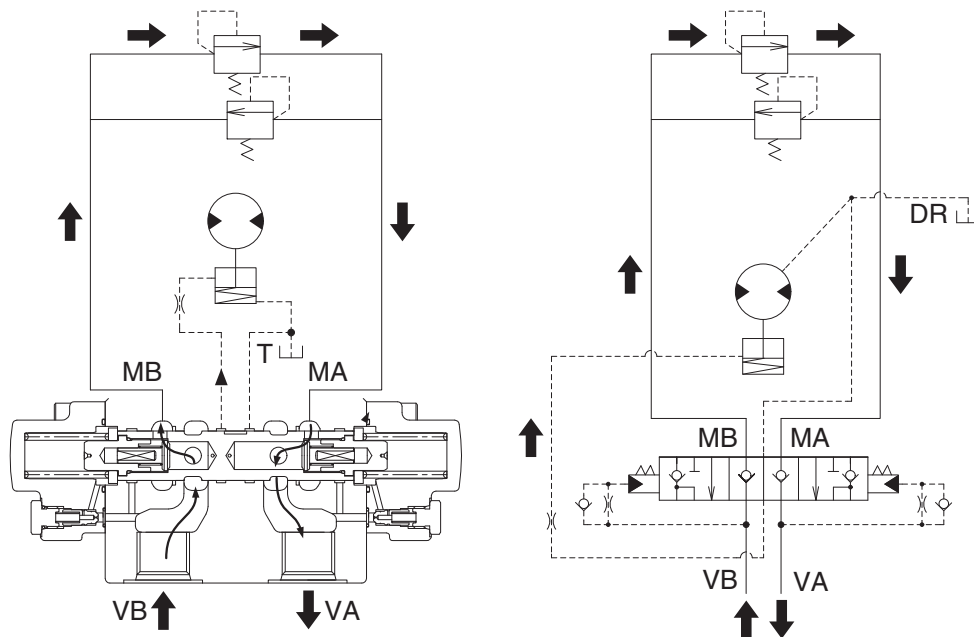

6) REDUCTION GEAR

Reduction unit slows down the rotating speed of motor and converts motor torque to strong rotating force.

This reduction unit utilizes two stages, planetary reduction system.

Planetary reduction system consists of sun gear, planetary gears, (planetary) carriers, and ring gear.

When the sun gear (s) is driven through input shaft, planetary pinions (b), rotating on their center, also move, meshing with fixed ring gear (a), around sun gear (s).

This movement is transferred to carrier (k) and deliver the torque.

This mechanism is called planetary gear mechanism.

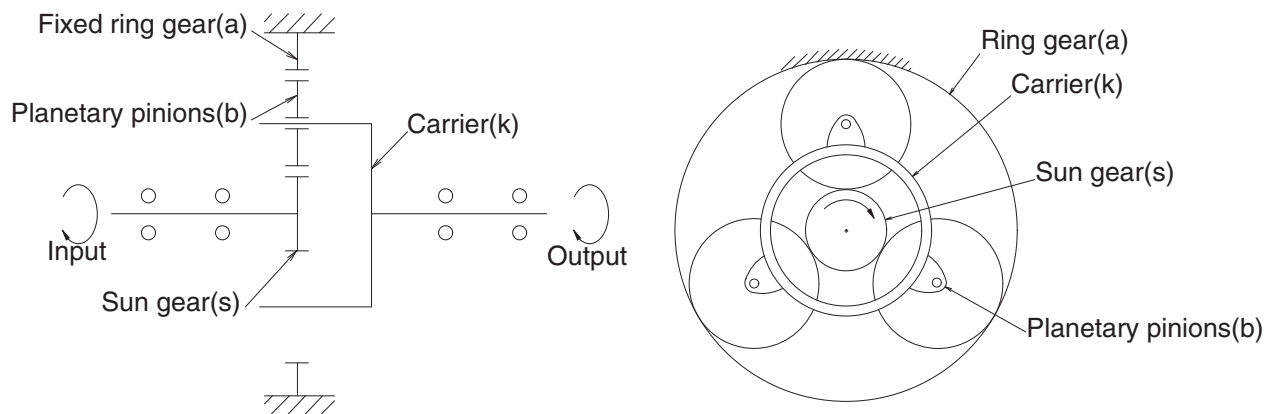

When the sun gear **S1** is driven by input shaft, planetary action occurs among gears **S1**, **a** and **b** and revolution of gear **b** transfers the rotation of carrier **K1** to second sun gear **S2**, and also evokes planetary action between gear **S2**, **a** and **d**.

This time, because carrier **K2** is fixed to frame, gear **d** drives ring gear **a** and then ring gear **a** rotates to drive sprocket.

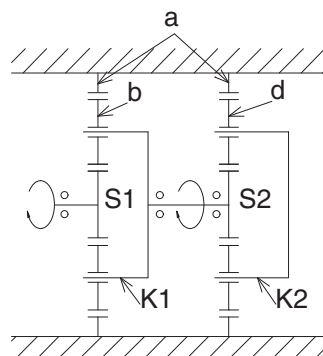

GROUP 5 RCV LEVER

1. STRUCTURE

The casing has the oil inlet port P (primary pressure) and the oil outlet port T (tank). In addition the secondary pressure is taken out through ports 1, 2, 3 and 4 provided at the bottom face.

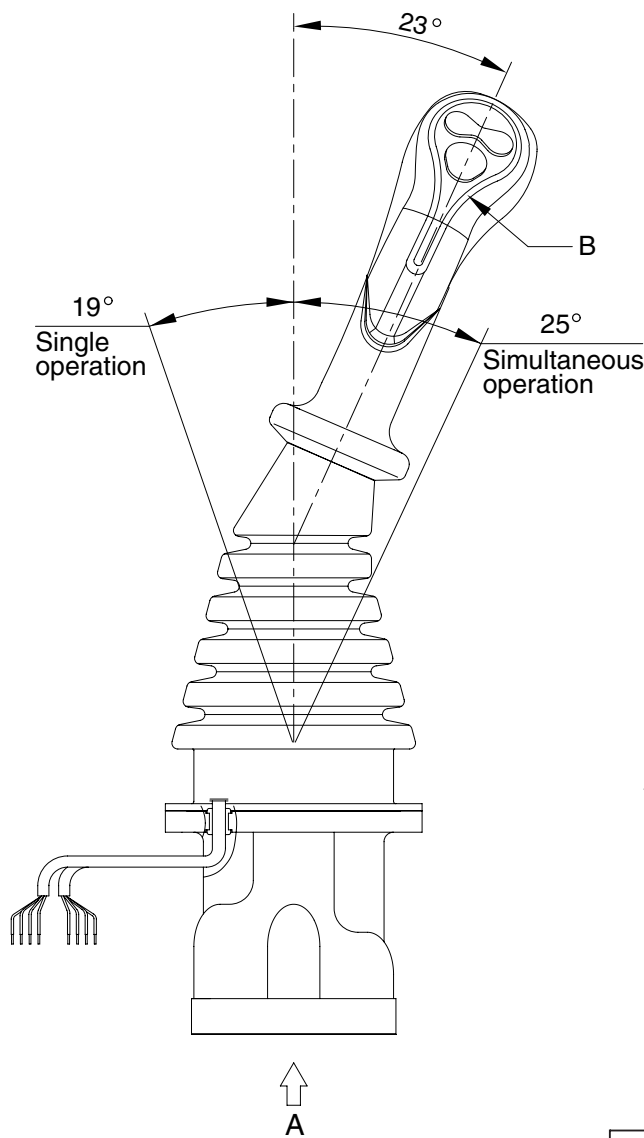

Switches

No.	LH	RH
5	One touch decel	Horn
6	Power boost	Breaker

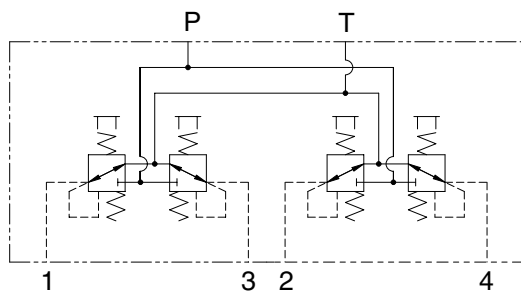
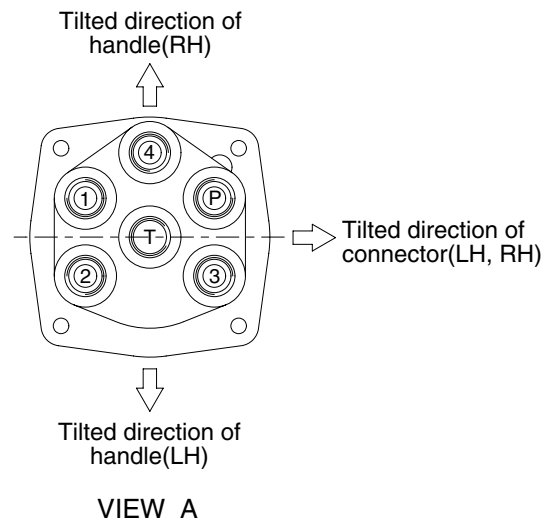
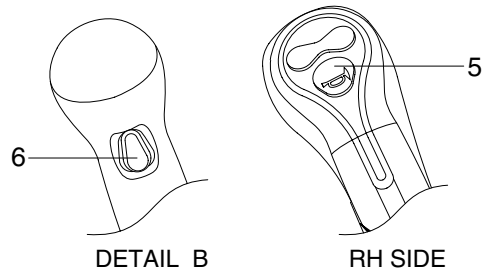

Hydraulic circuit

Port	LH	RH	Port size
P	Pilot oil inlet port	Pilot oil inlet port	PF 3/8
T	Pilot oil return port	Pilot oil return port	
1	Left swing port	Bucket out port	
2	Arm in port	Boom down port	
3	Right swing port	Bucket in port	
4	Arm out port	Boom up port	

CROSS SECTION

The construction of the pilot valve is shown in the attached cross section drawing. The casing has vertical holes in which reducing valves are assembled.

The pressure reducing section is composed of the spool (4), spring (6) for setting secondary pressure, return spring (10), stopper (8), spring seat (7, 13) and shim (5). The spring for setting the secondary pressure has been generally so preset that the secondary pressure is 5 to 20.5 kgf/cm² (depending on the type). The spool is pushed against the push rod (9, 11) by the return spring.

When the push rod is pushed down by tilting the handle, the spring seat comes down simultaneously and changes setting of the secondary pressure spring.

CROSS SECTION

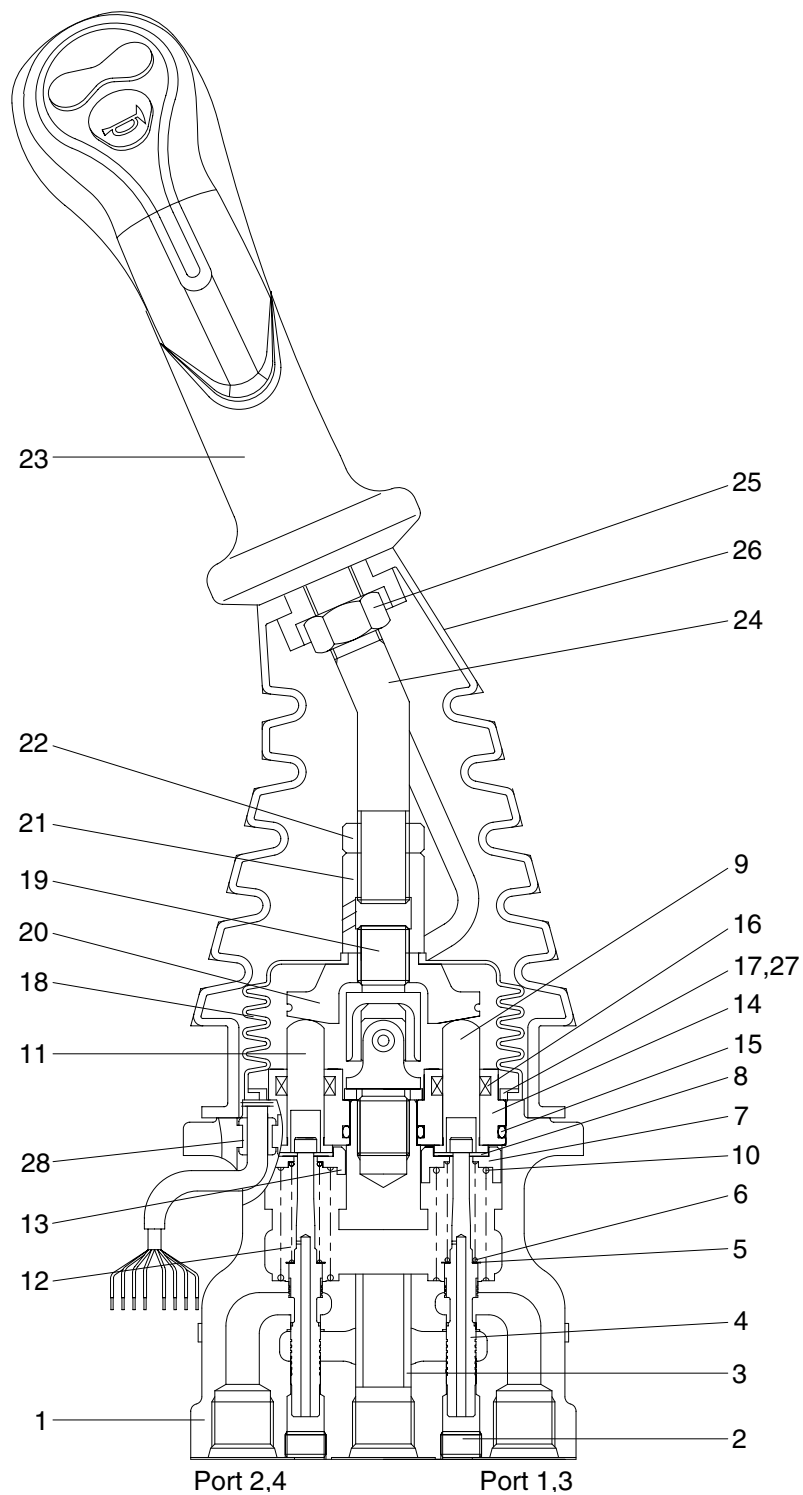

1	Case	8	Stopper	15	O-ring	22	Lock nut
2	Plug	9	Push rod	16	Rod seal	23	Handle assembly
3	Bushing	10	Spring	17	Plate	24	Handle bar
4	Spool	11	Push rod	18	Boot	25	Nut
5	Shim	12	Spring	19	Joint assembly	26	Boot
6	Spring	13	Spring seat	20	Swash plate	27	Spring pin
7	Spring seat	14	Plug	21	Adjusting nut	28	Bushing

2. FUNCTIONS

1) FUNDAMENTAL FUNCTIONS

The pilot valve is a valve that controls the spool stroke, direction, etc of a main control valve. This function is carried out by providing the spring at one end of the main control valve spool and applying the output pressure (secondary pressure) of the pilot valve to the other end.

For this function to be carried out satisfactorily, the pilot valve is composed of the following elements.

- (1) Inlet port (P) where oil is supplied from hydraulic pump.
- (2) Output ports (1, 2, 3 & 4) to apply pressure supplied from inlet port to ends of control valve spools.
- (3) Tank port (T) necessary to control the above output pressure.
- (4) Spool to connect output port to inlet port or tank port.
- (5) Mechanical means to control output pressure, including springs that work on the above spools.

2) FUNCTIONS OF MAJOR SECTIONS

The functions of the spool (4) are to receive the supply oil pressure from the hydraulic pump at its port P, and to change over oil paths to determine whether the pressure oil of port P is led to output ports 1, 2, 3 & 4 or the output port pressure oil to tank port T.

The spring (6) works on this spool to determine the output pressure.

The change the deflection of this spring, the push rod (9,11) is inserted and can slide in the plug (14).

For the purpose of changing the displacement of the push rod through the swash plate (20) and adjusting nut (21) are provided the handle (23) that can be tilted in any direction around the fulcrum of the universal joint (19) center.

The spring (10) works on the case (1) and spring seat (7, 13) and tries to return the push rod (9,11) to the zero-displacement position irrespective of the output pressure, securing its resetting to the center position.

This also has the effect of a reaction spring to give appropriate control feeling to the operator.

3) OPERATION

The operation of the pilot valve will be described on the basis of the hydraulic circuit diagram shown below and the attached operation explanation drawing.

The diagram shown below is the typical application example of the pilot valve.

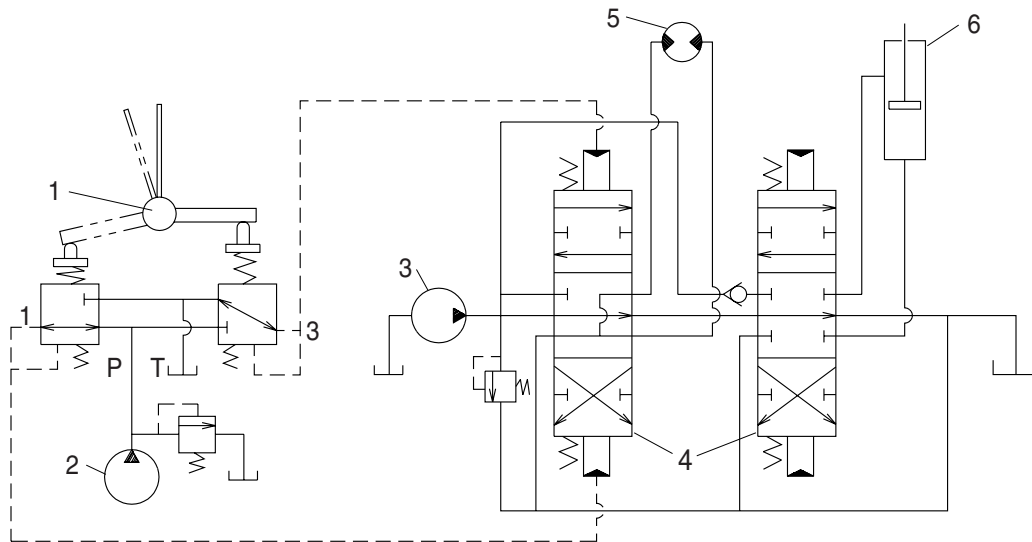

- 1 Pilot valve
- 2 Pilot pump

- 3 Main pump
- 4 Main control valve

- 5 Hydraulic motor
- 6 Hydraulic cylinder

(1) Case where handle is in neutral position

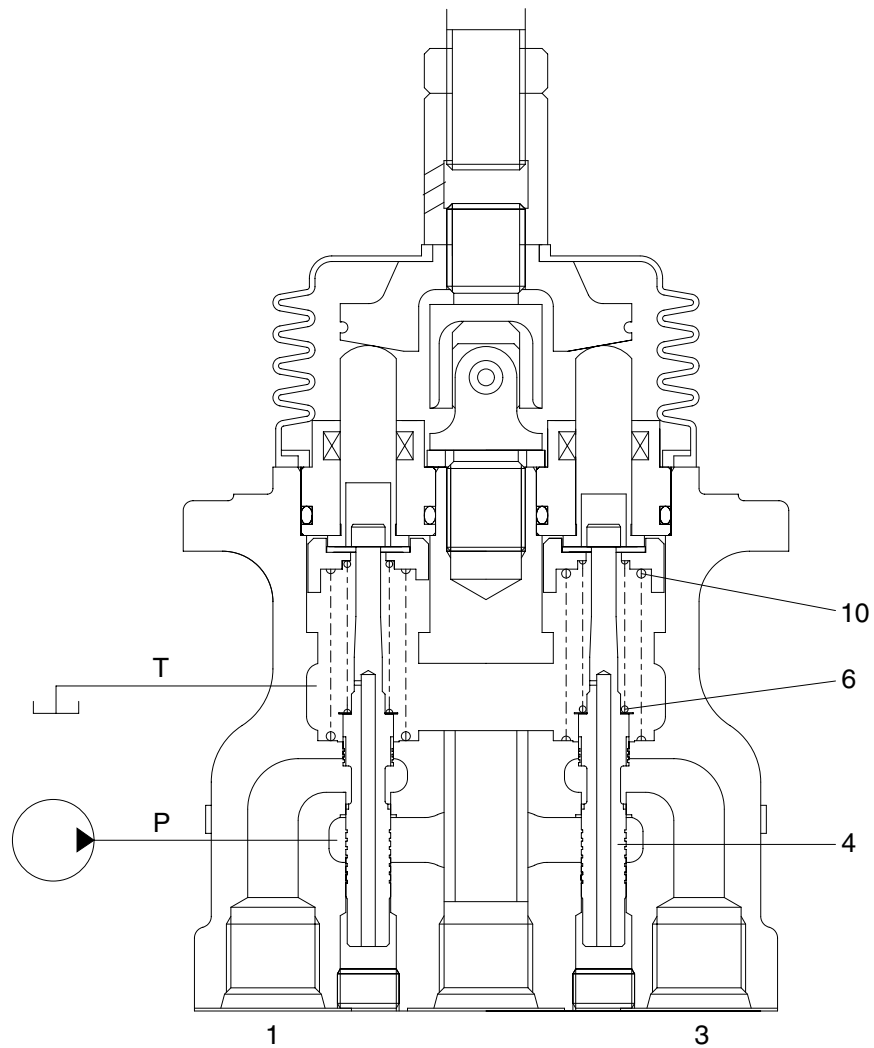

The force of the spring (6) that determines the output pressure of the pilot valve is not applied to the spool (4). Therefore, the spool is pushed up by the spring (10) to the position of port (1, 3) in the operation explanation drawing. Then, since the output port is connected to tank port T only, the output port pressure becomes equal to tank pressure.

(2) Case where handle is tilted

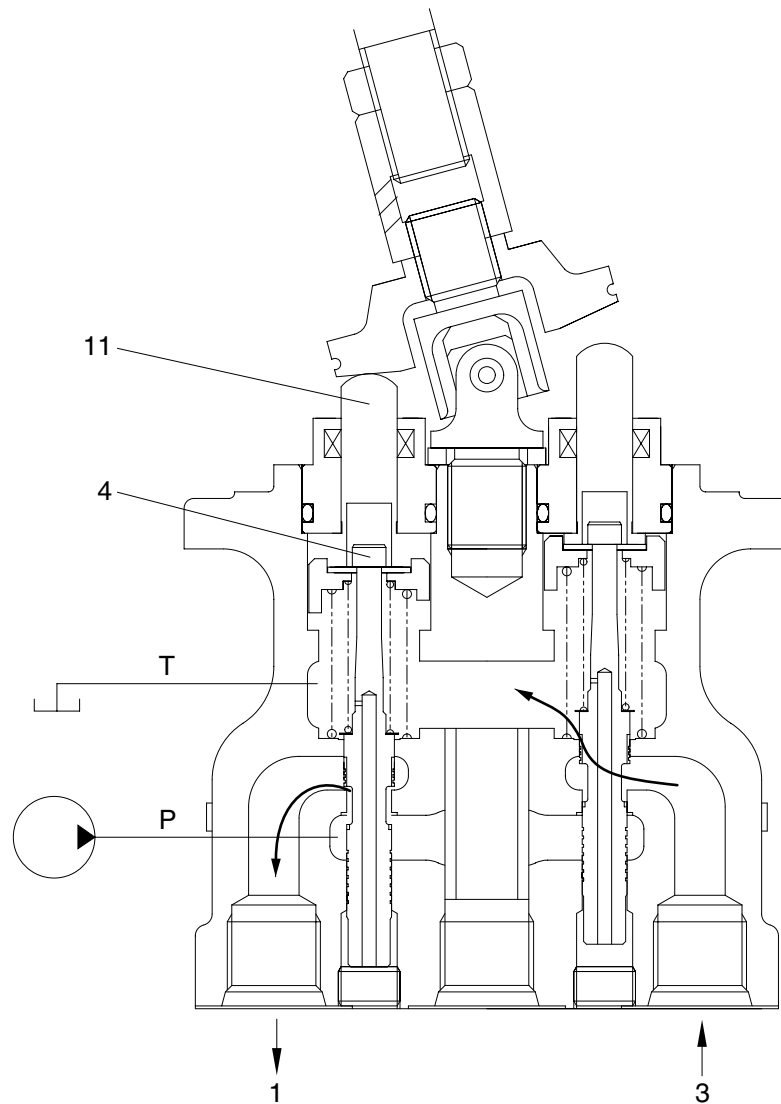

When the push rod (11) is stroked, the spool (4) moves downwards.

Then port P is connected with port (1) and the oil supplied from the pilot pump flows through port (1) to generate the pressure.

When the pressure at port (1) increases to the value corresponding to the spring force set by tilting the handle, the hydraulic pressure force balances with the spring force. If the pressure at port (1) increases higher than the set pressure, port P is disconnected from port (1) and port T is connected with port (1). If it decreases lower than the set pressure, port P is connected with port (1) and port T is disconnected from port 1.

In this manner the secondary pressure is kept at the constant value.

Besides, in some type, when the handle is tilted more than a certain angle, the upper end of the spool contacts with the inside bottom of the push rod and the output pressure is left to be connected with port P.

GROUP 6 RCV PEDAL

1. STRUCTURE

The casing (spacer) has the oil inlet port P (primary pressure), and the oil outlet port T (tank). In addition the secondary pressure is taken out through ports 1, 2, 3 and 4 provided at the bottom face.

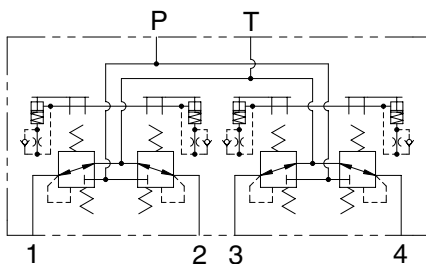
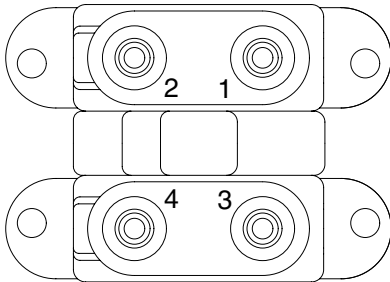
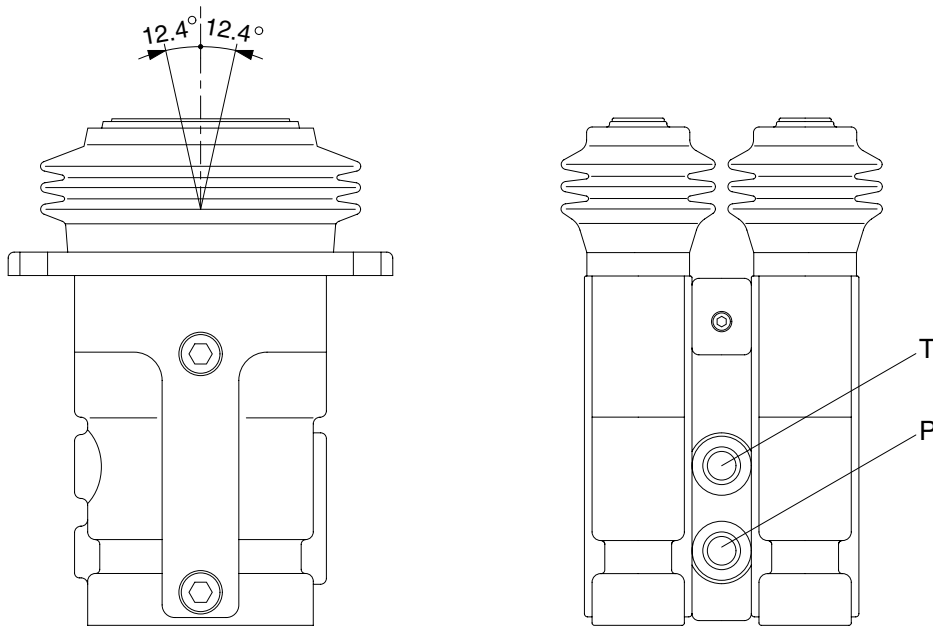

Hydraulic circuit

Port	Port	Port size
P	Pilot oil inlet port	PF 1/4
T	Pilot oil return port	
1	Travel (LH, Forward)	
2	Travel (LH, Backward)	
3	Travel (RH, Forward)	
4	Travel (RH, Backward)	

CROSS SECTION

The construction of the RCV pedal is shown in the below drawing. The casing has vertical holes in which reducing valves are assembled.

The pressure reducing section is composed of the spool (8), spring (6) for setting secondary pressure, return spring (10), stopper (9), and spring seat (7). The spring for setting the secondary pressure has been generally so preset that the secondary pressure is 5 to 19 kgf/cm² (depending on the type). The spool is pushed against the push rod (14) by the return spring.

When the push rod is pushed down by tilting pedal, the spring seat comes down simultaneously and changes setting of the secondary pressure spring.

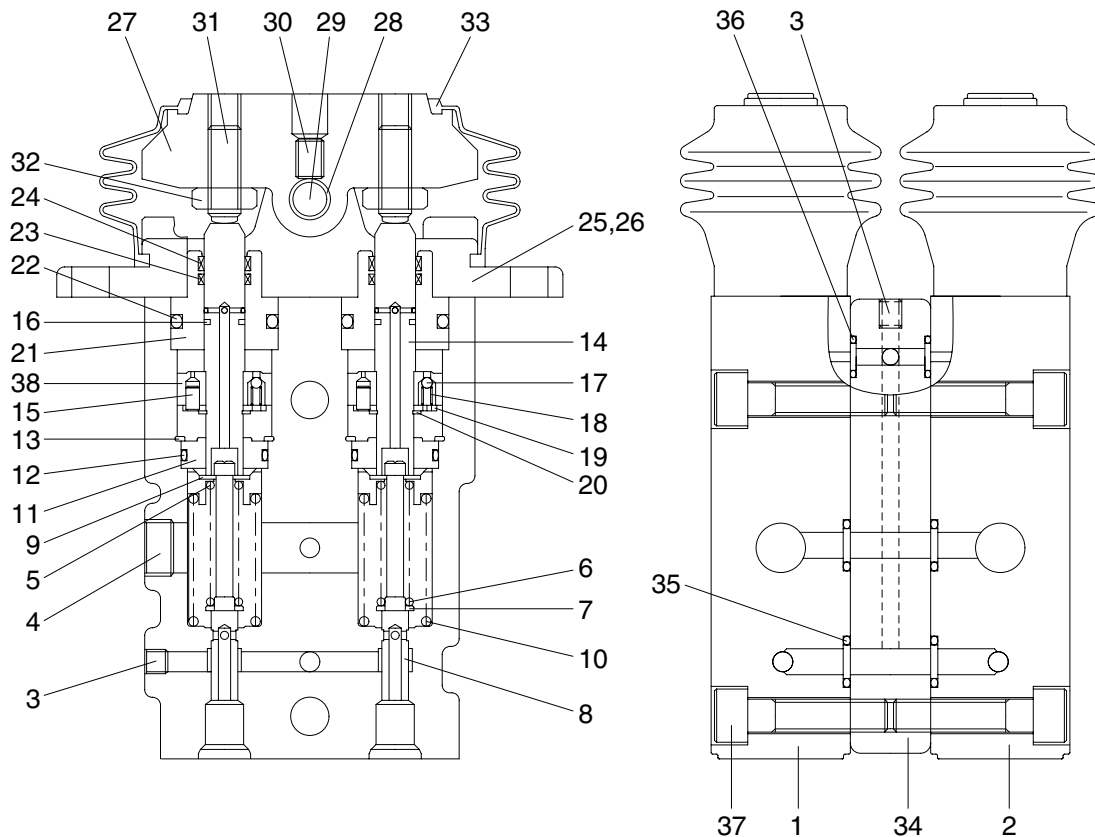

1	Body(1)	14	Push rod	27	Cam
2	Body(2)	15	Spring pin	28	Bushing
3	Plug	16	Seal	29	Cam shaft
4	Plug	17	Steel ball	30	Set screw
5	Spring seat	18	Spring	31	Set screw
6	Spring	19	Plate	32	Nut
7	Spring seat	20	Snap ring	33	Bellows
8	Spool	21	Plug	34	Space
9	Stopper	22	O-ring	35	O-ring
10	Spring	23	Rod seal	36	O-ring
11	Rod guide	24	Dust seal	37	Socket bolt
12	O-ring	25	Cover	38	Piston
13	Snap ring	26	Socket bolt		

2. FUNCTION

1) FUNDAMENTAL FUNCTIONS

The pilot valve is a valve controls the spool stroke, direction, etc of a main control valve. This function is carried out by providing the spring at one end of the main control valve spool and applying the output pressure (secondary pressure) of the pilot valve to the other end.

For this function to be carried out satisfactorily, the pilot valve is composed of the following elements.

- (1) Inlet port (P) where oil is supplied from hydraulic pump.
- (2) Output port (1, 2, 3 & 4) to apply pressure supplied from inlet port to ends of control valve spools.
- (3) Tank port (T) necessary to control the above output pressure.
- (4) Spool to connect output port to inlet port tank port.
- (5) Mechanical means to control output pressure, including springs that work on the above spools.

2) FUNCTIONS OF MAJOR SECTIONS

The functions of the spool (8) are to receive the supply oil pressure from the hydraulic pump at its port P, and to change over oil paths to determine whether the pressure oil of port P is led to output ports 1, 2, 3 & 4 or the output spool to determine the output pressure.

The spring (6) works on this spool to determine the output pressure.

The change the deflection of this spring, the push rod (14) is inserted and can slide in the plug (21). For the purpose of changing th displacement of the push rod through the cam (27) and adjusting nut (32) are provided the pedal that can be tilted in any direction around the fulcrum of the cam (27) center.

The spring (10) works on the casing (1) and spring seat (7) and tries to return the push rod (14) to the zero-displacement position irrespective of the output pressure, securing its resetting to the center position.

This also has the effect of a reaction spring to give appropriate control feeling to the operator.

3) OPERATION

The operation of the pilot valve will be described on the basis of the hydraulic circuit diagram shown below and the attached operation explanation drawing.

The diagram shown below is the typical application example of the pilot valve.

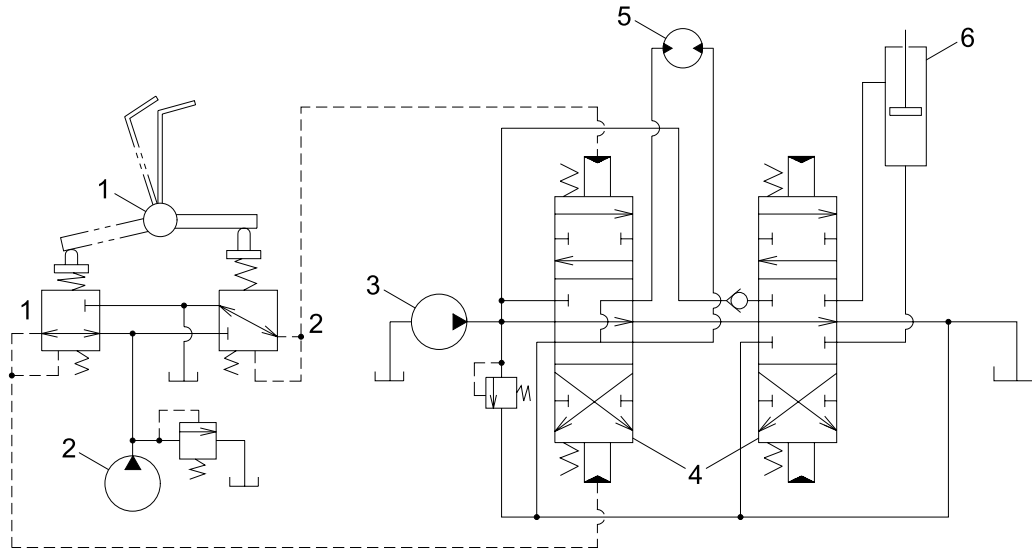

1 Pilot valve
2 Pilot pump

3 Main pump
4 Main control valve

5 Hydraulic motor
6 Hydraulic cylinder

(1) Case where pedal is in neutral position

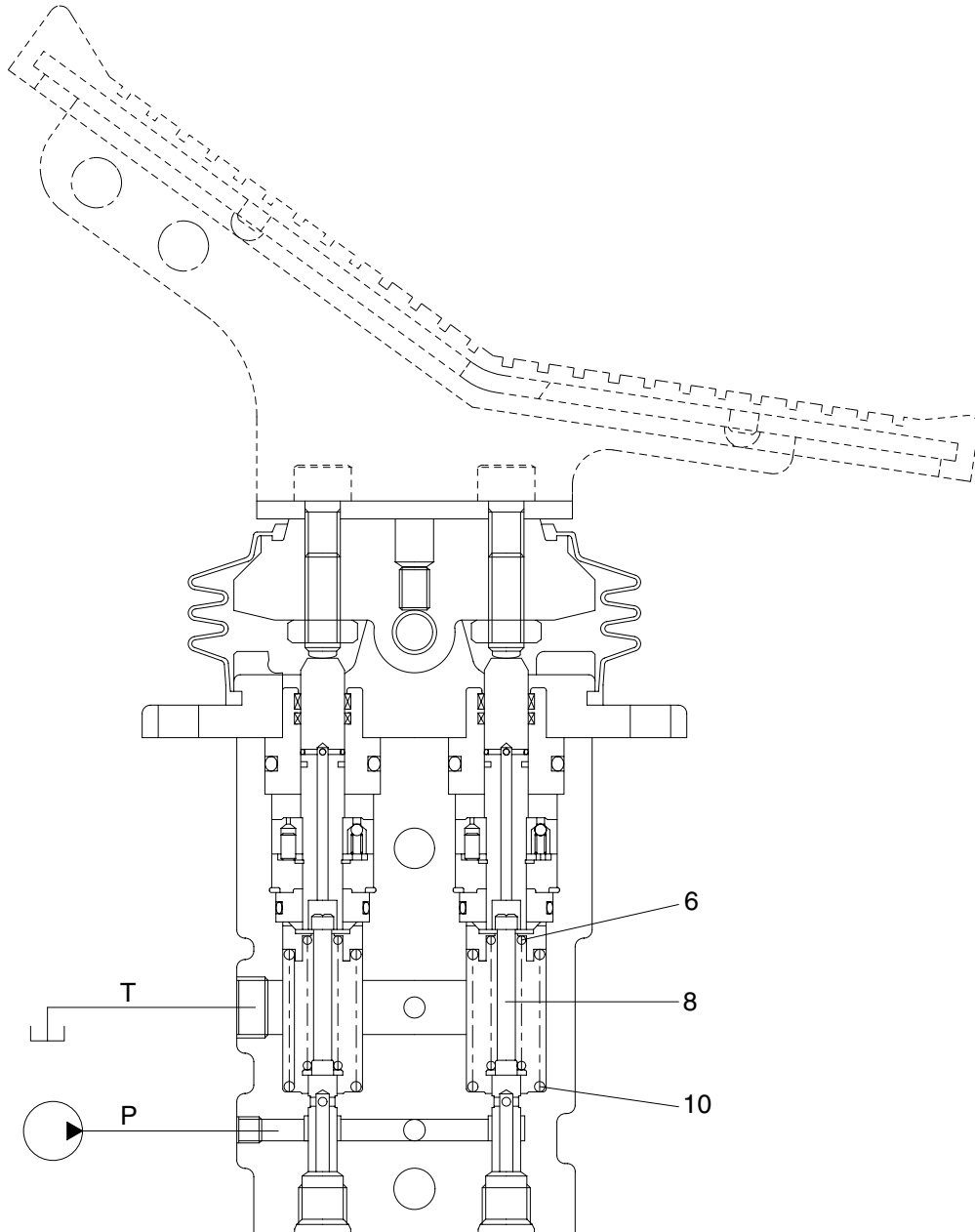

The force of the spring (6) that determines the output pressure of the pilot valve is not applied to the spool (8). Therefore, the spool is pushed up by the spring (10) to the position of port 2 in the operation explanation drawing. Then, since the output port is connected to tank port T only, the output port pressure becomes equal to tank pressure.

(2) Case where pedal is tilted

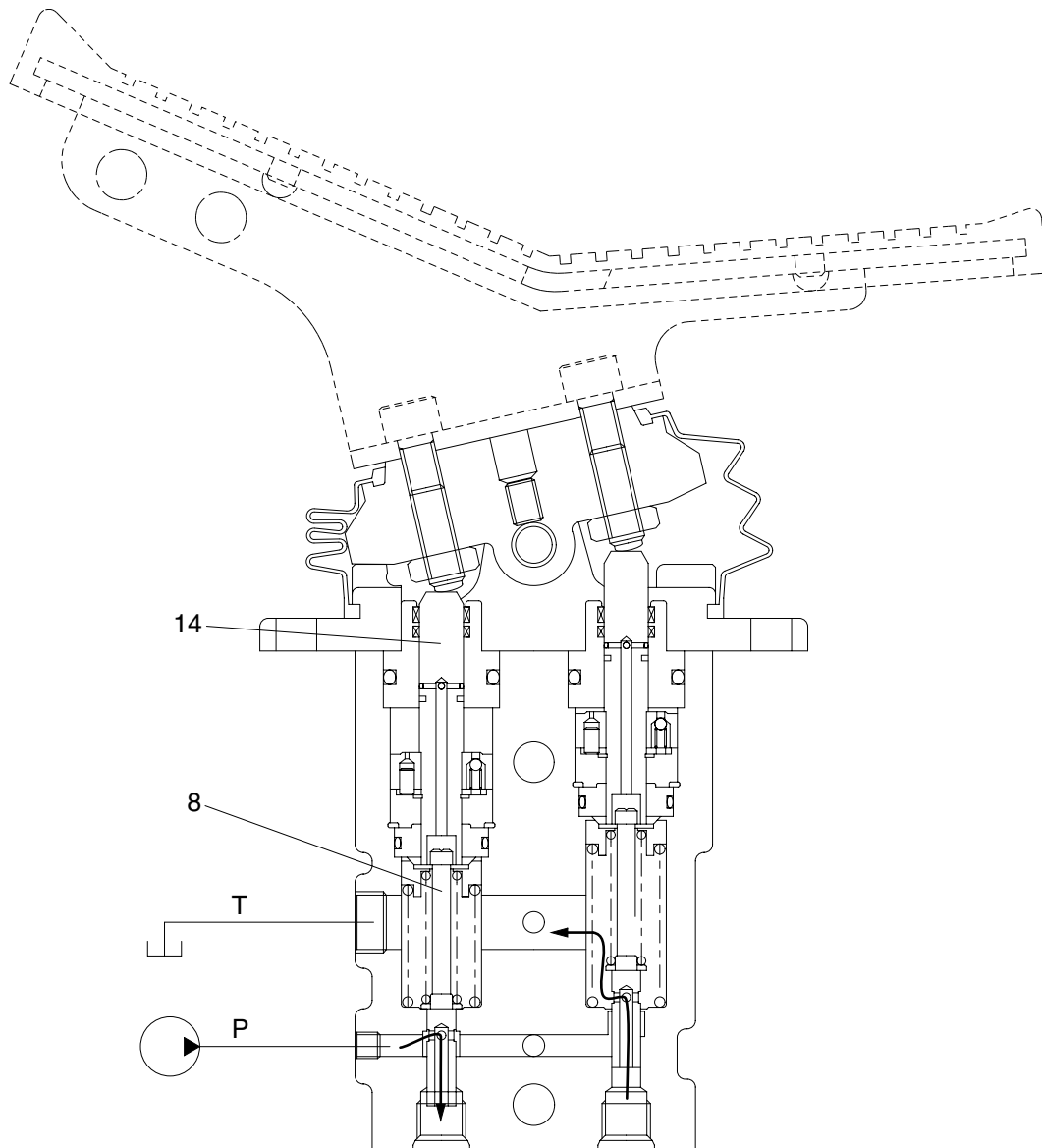

When the push rod (14) is stroked, the spool (8) moves downwards.

Then port P is connected with port 1, and the oil supplied from the pilot pump flows through port 1 to generate the pressure.

When the pressure at port 1 increases to the value corresponding to the spring force set by tilting the handle, the hydraulic pressure force balances with the spring force. If the pressure at port 1 increases higher than the set pressure, port P is disconnected from port 1 and port T is connected with port 1. If it decreases lower than the set pressure, port P is connected with port 1 and port T is disconnected from port 1.

In this manner the secondary pressure is kept at the constant value.

Besides, in some type, when the handle is tilted more than a certain angle, the upper end of the spool contacts with inside bottom of the push rod and the output pressure is left to be connected with port P.