

SECTION 4 ELECTRICAL SYSTEM

Group 1 Component Location	4-1
Group 2 Electrical Circuit	4-3
Group 3 Electrical Component Specification	4-18
Group 4 Connectors	4-25

SECTION 4 ELECTRICAL SYSTEM

GROUP 1 COMPONENT LOCATION

1. LOCATION 1

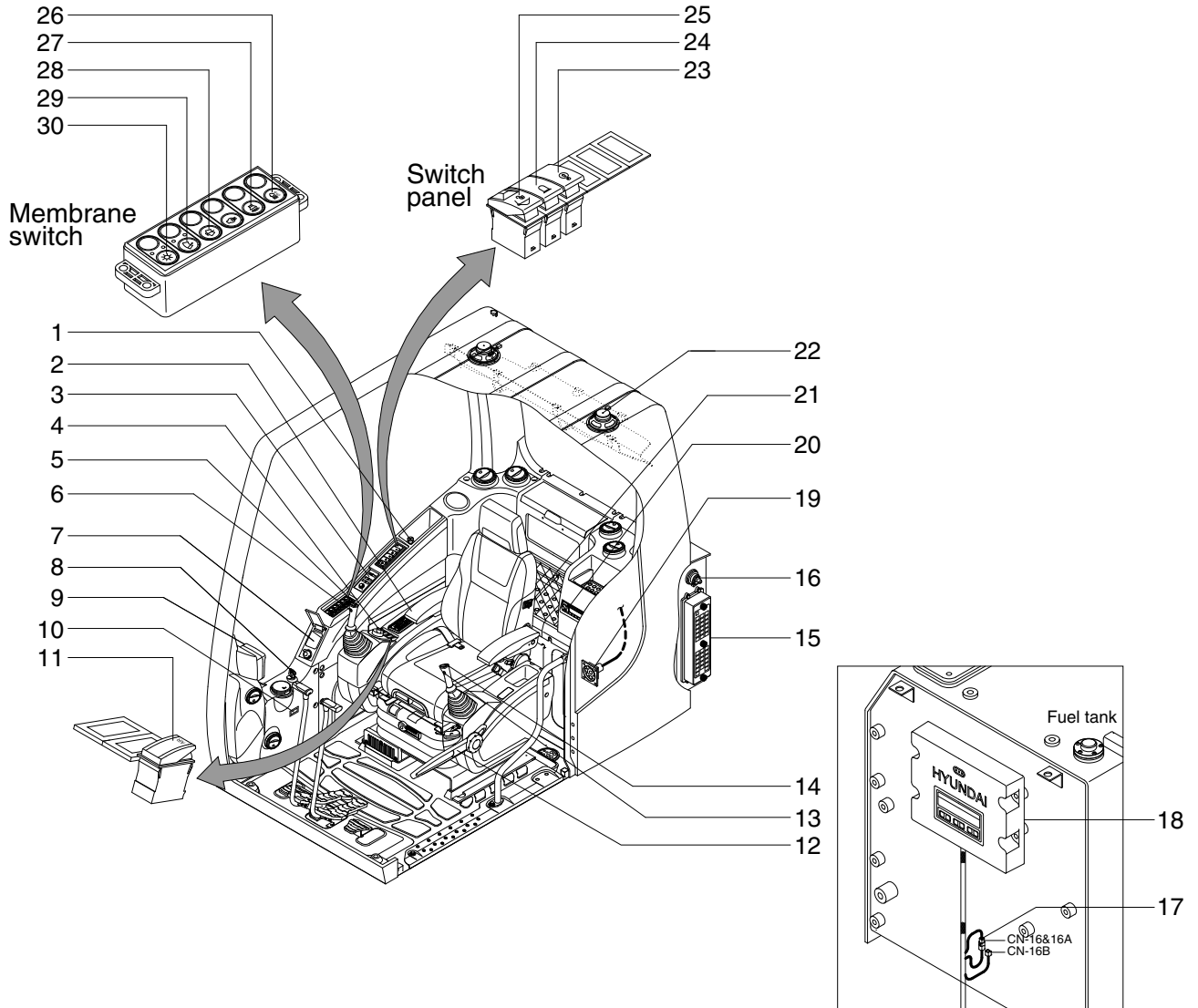

- | | | |
|----------------------------|----------------------------------|-------------------------------|
| 1 Cigar lighter | 11 Air compressor switch(option) | 21 Heated seat switch |
| 2 Air conditioner switch | 12 Safety lever | 22 Speaker |
| 3 Remote controller | 13 Power max switch | 23 Overload switch(option) |
| 4 Accel dial switch | 14 One touch decel switch | 24 Beacon switch(option) |
| 5 Horn switch | 15 Fuse & relay box | 25 Quick clamp switch(option) |
| 6 Breaker operation switch | 16 Master switch | 26 Cab light switch |
| 7 Handsfree | 17 Emergency engine connector | 27 Travel alarm switch |
| 8 Start switch | 18 Machine control unit | 28 Washer switch |
| 9 Cluster | 19 RS232 & J1939 service socket | 29 Wiper switch |
| 10 Hour meter | 20 Radio & USB player | 30 Main light switch |

2. LOCATION 2

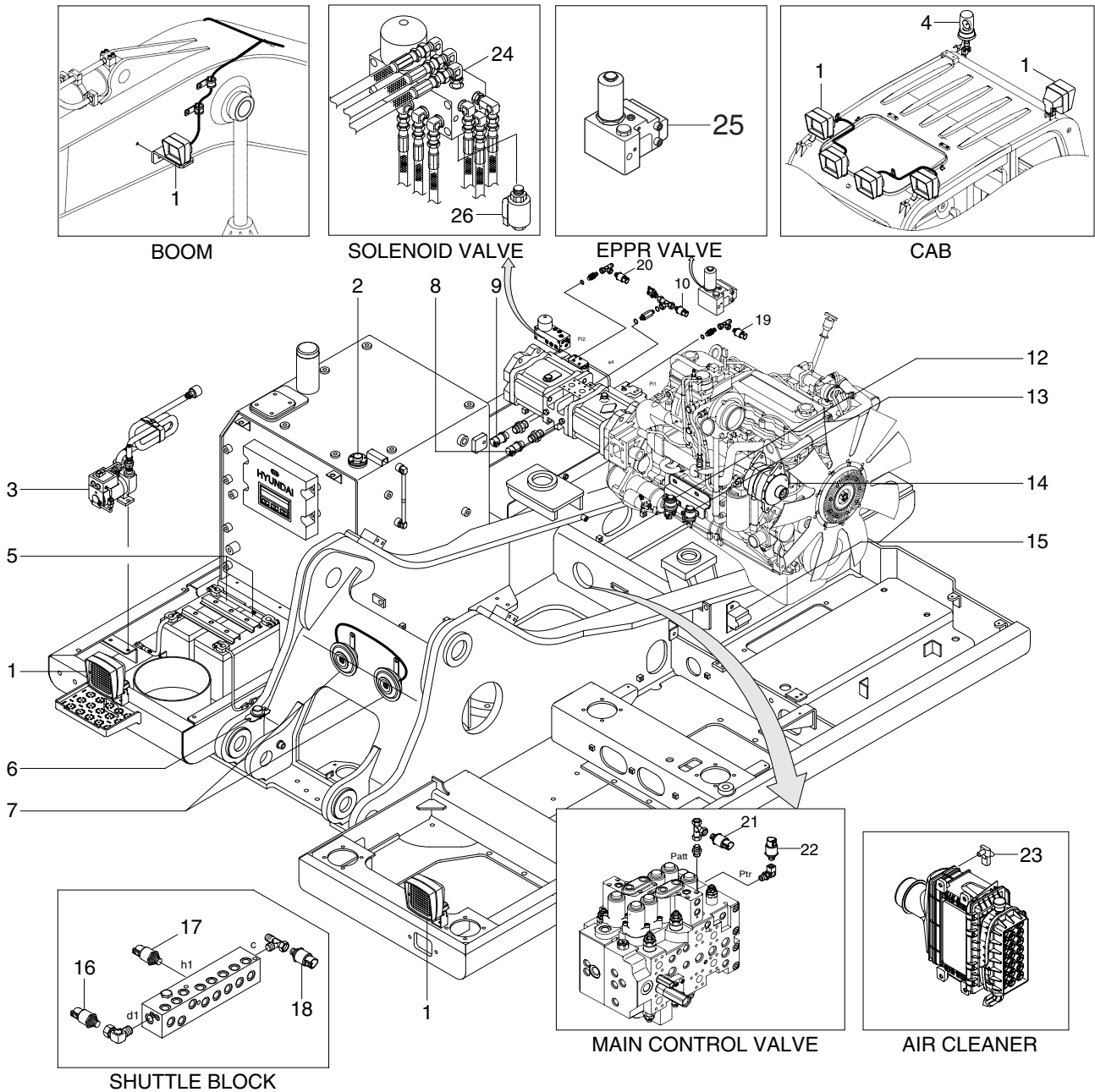

- | | | | | | |
|---|--------------------|----|-------------------------------|----|-----------------------------|
| 1 | Lamp | 10 | EPPR pressure sensor | 20 | Posi-nega 2 pressure sensor |
| 2 | Fuel sender | 12 | Start relay | 21 | Attach pressure sensor |
| 3 | Fuel filler pump | 13 | Heater relay | 22 | Travel pressure sensor |
| 4 | Beacon lamp | 14 | Alternator | 23 | Air cleaner sensor |
| 5 | Battery | 15 | Travel alarm buzzer | 24 | Solenoid valve |
| 6 | Battery relay | 16 | Arm/Bucket in pressure sensor | 25 | Pump EPPR valve |
| 7 | Horn | 17 | Boom up pressure sensor | 26 | Boom priority EPPR valve |
| 8 | P1 pressure sensor | 18 | Swing pressure sensor | | |
| 9 | P2 pressure sensor | 19 | Posi-nega 1 pressure sensor | | |

GROUP 2 ELECTRICAL CIRCUIT (1/2 , GCIC QSB7 ENGINE)

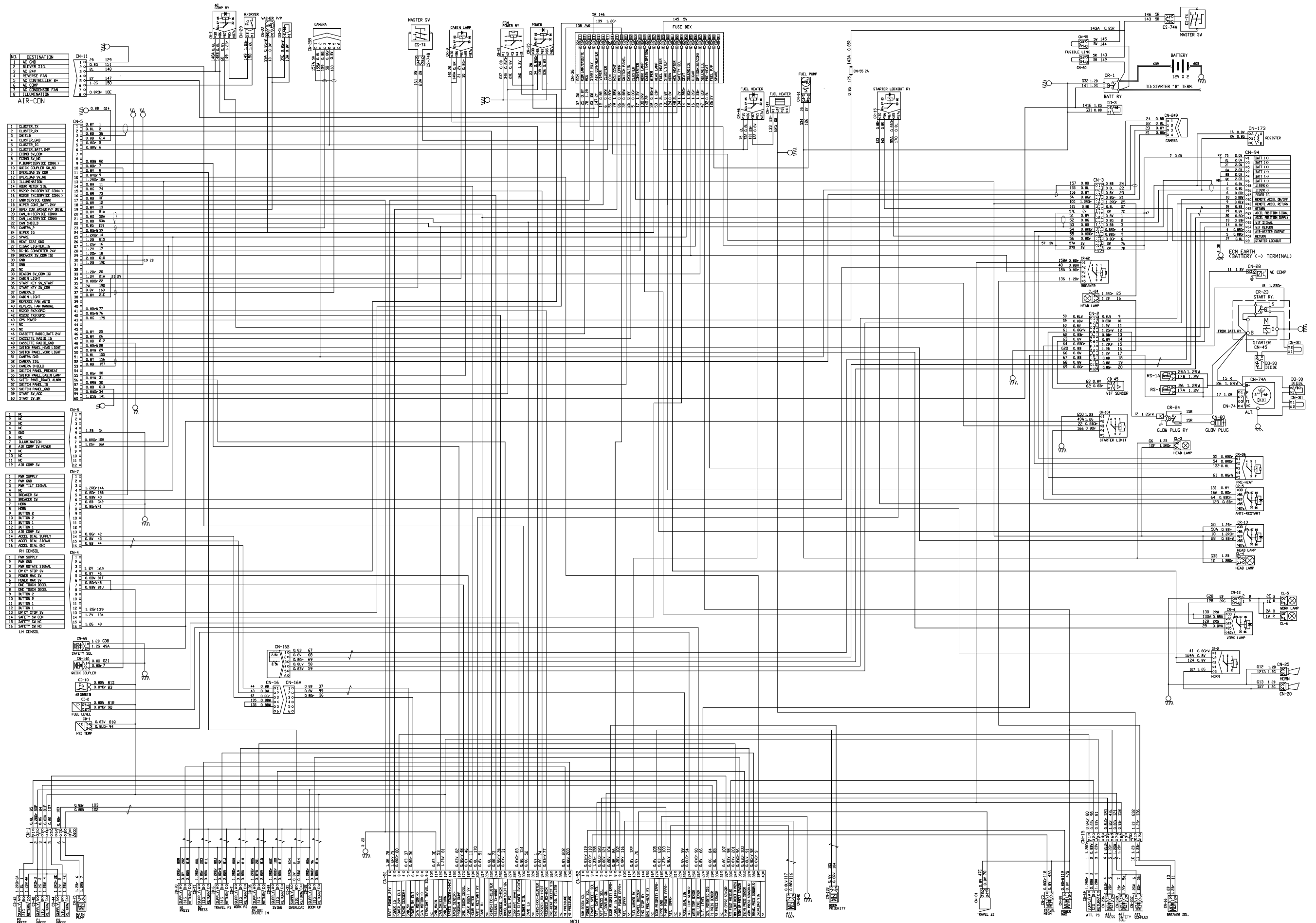

ELECTRICAL CIRCUIT (2/2)

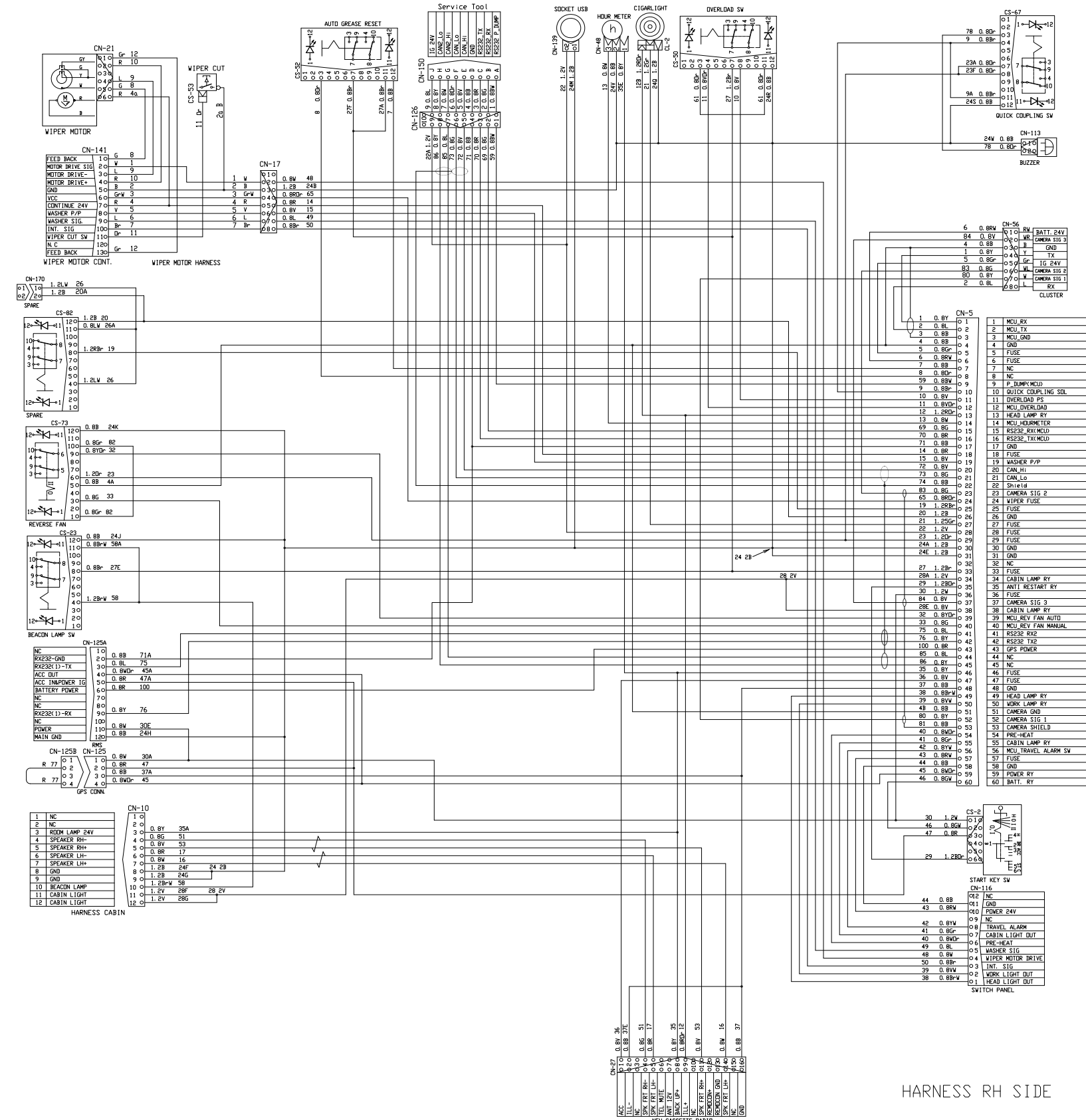

HARNESS RH SIDE

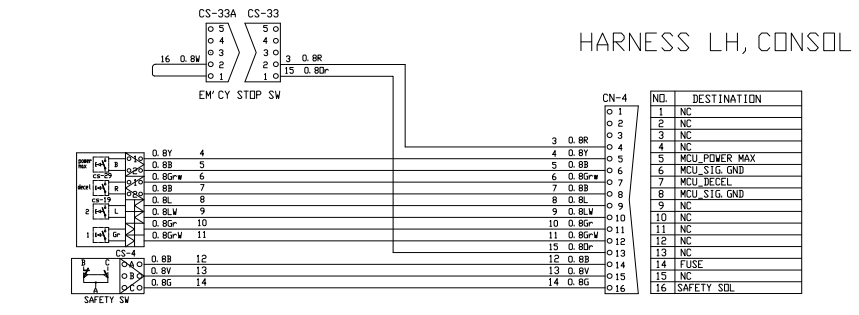
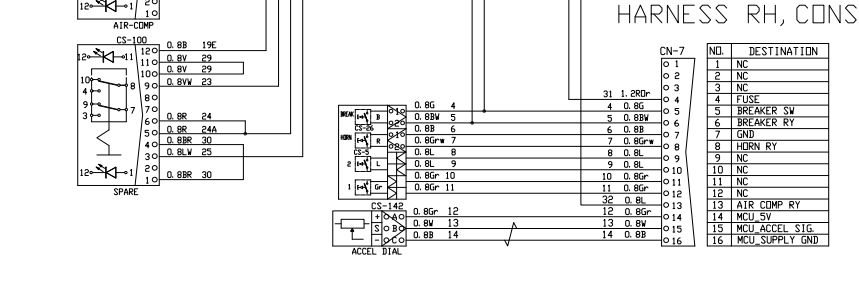
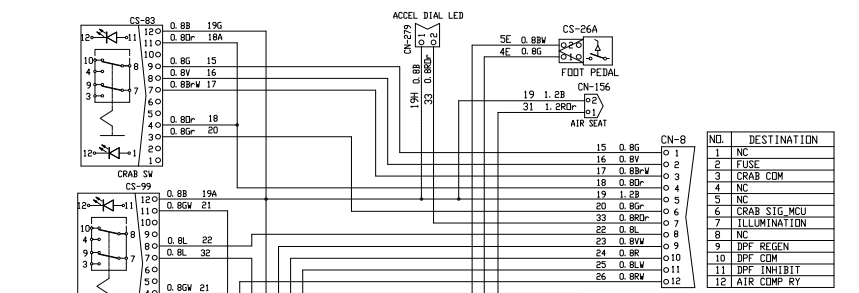
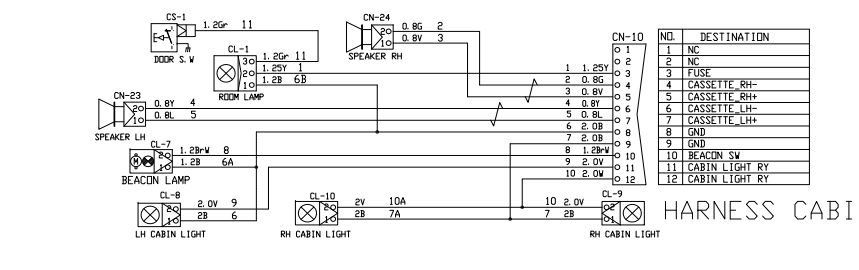
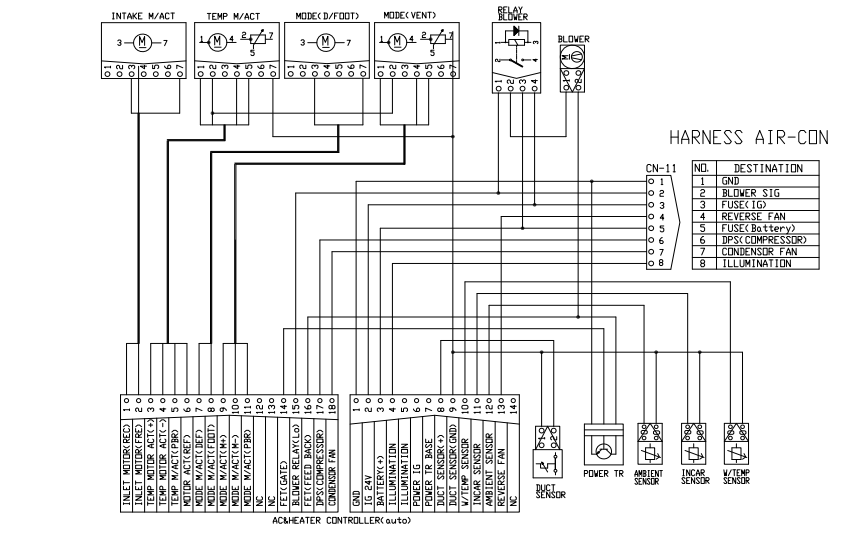

MEMORANDUM

HYUNDAI HEAVY INDUSTRIES CO., LTD
CONSTRUCTION EQUIPMENT DIV.

1. POWER CIRCUIT(GCIC QSB7 ENGINE)

The negative terminal of battery is grounded to the machine chassis.

When the start switch is in the OFF position, the current flows from the positive battery terminal as shown below.

1) OPERATING FLOW

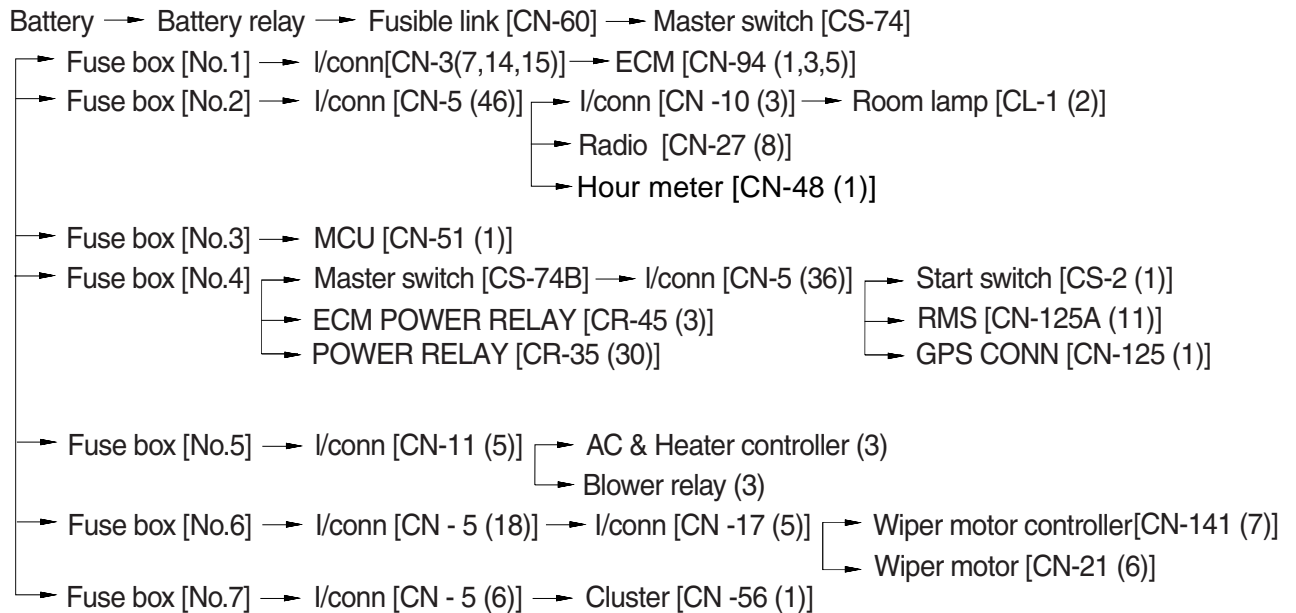

※ I/conn : Intermediate connector

2) CHECK POINT

Engine	Start switch	Check point	Voltage
OFF	OFF	① - GND (battery 1EA) ② - GND (battery 2EA) ③ - GND (battery 2EA) ④ - GND (fusible link)	0 V 20~25V 20~25V 20~25V

※ GND : Ground

POWER CIRCUIT (GCIC QSB7 ENGINE)

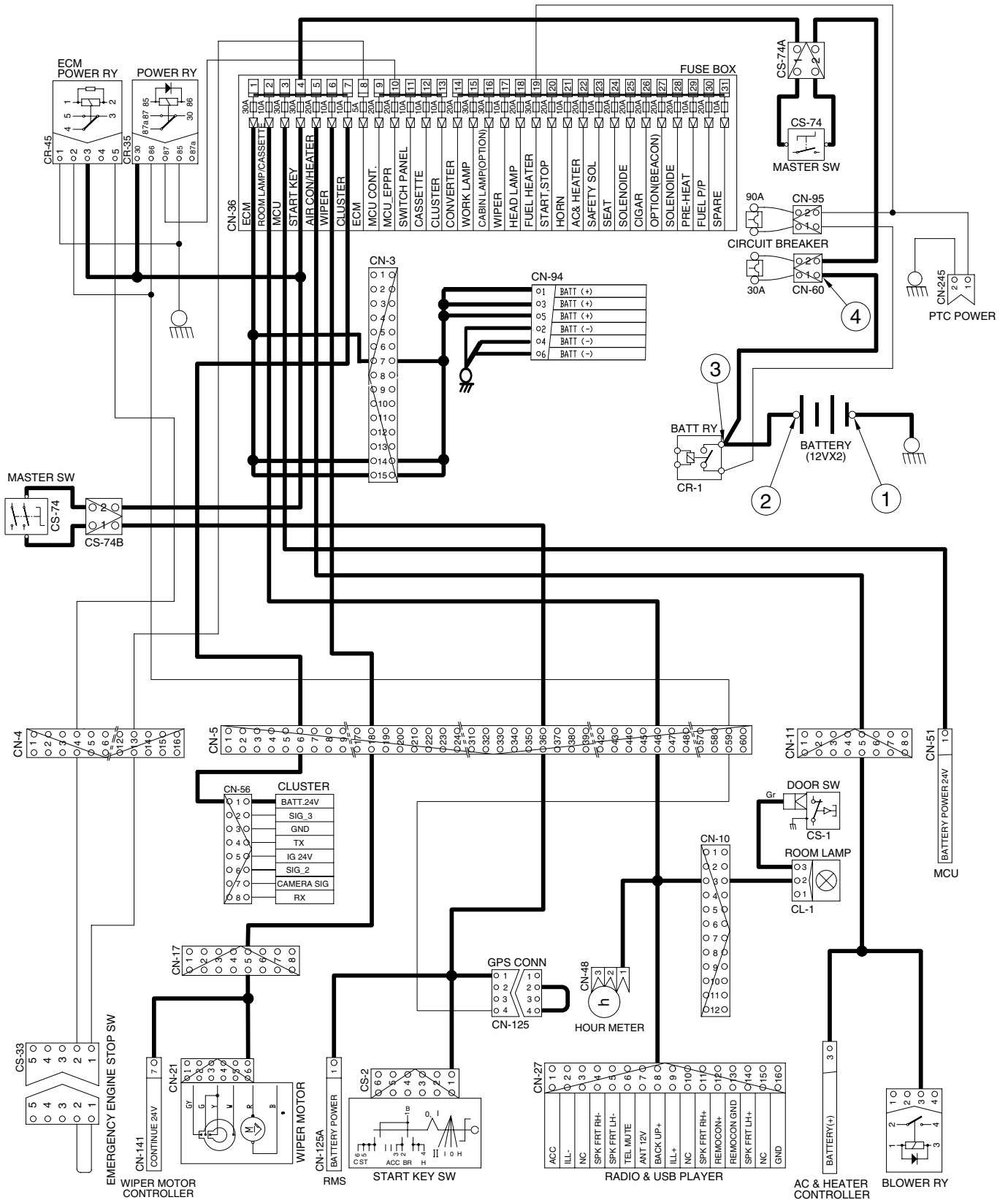

2. STARTING CIRCUIT (GCIC QSB7 ENGINE)

1) OPERATING FLOW

Battery(+) terminal → Battery relay [CR-1] → Circuit breaker [CN-60] → Master switch [CS-74]
 → Fuse box [No.4] → I/conn [CN-5(36)] → Start switch [CS-2(1)]

(1) When start key switch is in ON position

Start switch ON [CS-2 (2)] → I/conn [CN-5 (60)] → Battery relay [CR-1]
 → Battery relay operating (all power is supplied with the electric component)
 Start switch ON [CS-2 (3)] → RMS [CN-125A (5)]
 → RMS conn [CN-125 (2)→(4)] → I/conn [CN-5 (59)]
 Power relay [CR-35 (86) → (87)] → Fuse box [No.10]
 ECM power relay [CR-45 (2) → (5)] → I/conn [CN-4 (4)]
 → Emergency engine stop sw [CN-33 (2) → (1)] → I/conn [CN-4 (13)] → Fuse box [No. 8]

(2) When start key switch is in START position

Start switch START [CS-2 (6)] → I/conn [CN-5 (35)] → Stater limit relay[CR-104(3)→(4)]
 → Anti-restart relay [CR-5 (86)]

ECM [CN-94 (9)] → I/conn [CN-3 (6)] → Starter lockout relay [CR-15(86)]

ECM [CN-94 (57)] → I/conn [CN-3 (12)] → Starter lockout relay [CR-15(85)]

MCU [CN-51 (20)] → Starter lockout relay [CR-15(87a)→(30)] → Anti-restart relay [CR-5 (85)]

Anti-restart relay [CR-5 (30) →(87)] → I/conn [CN-2 (4)] → Start relay [CR-23(2)]

2) CHECK POINT

Engine	Start switch	Check point	Voltage
OPERATING	START	① - GND (battery) ② - GND (start key) ③ - GND (battery relay M4) ④ - GND (starter B ⁺) ⑤ - GND (starter M) ⑥ - GND (start relay) ⑦ - GND (battery relay M8)	20~25V

STARTING CIRCUIT (GCIC QSB7 ENGINE)

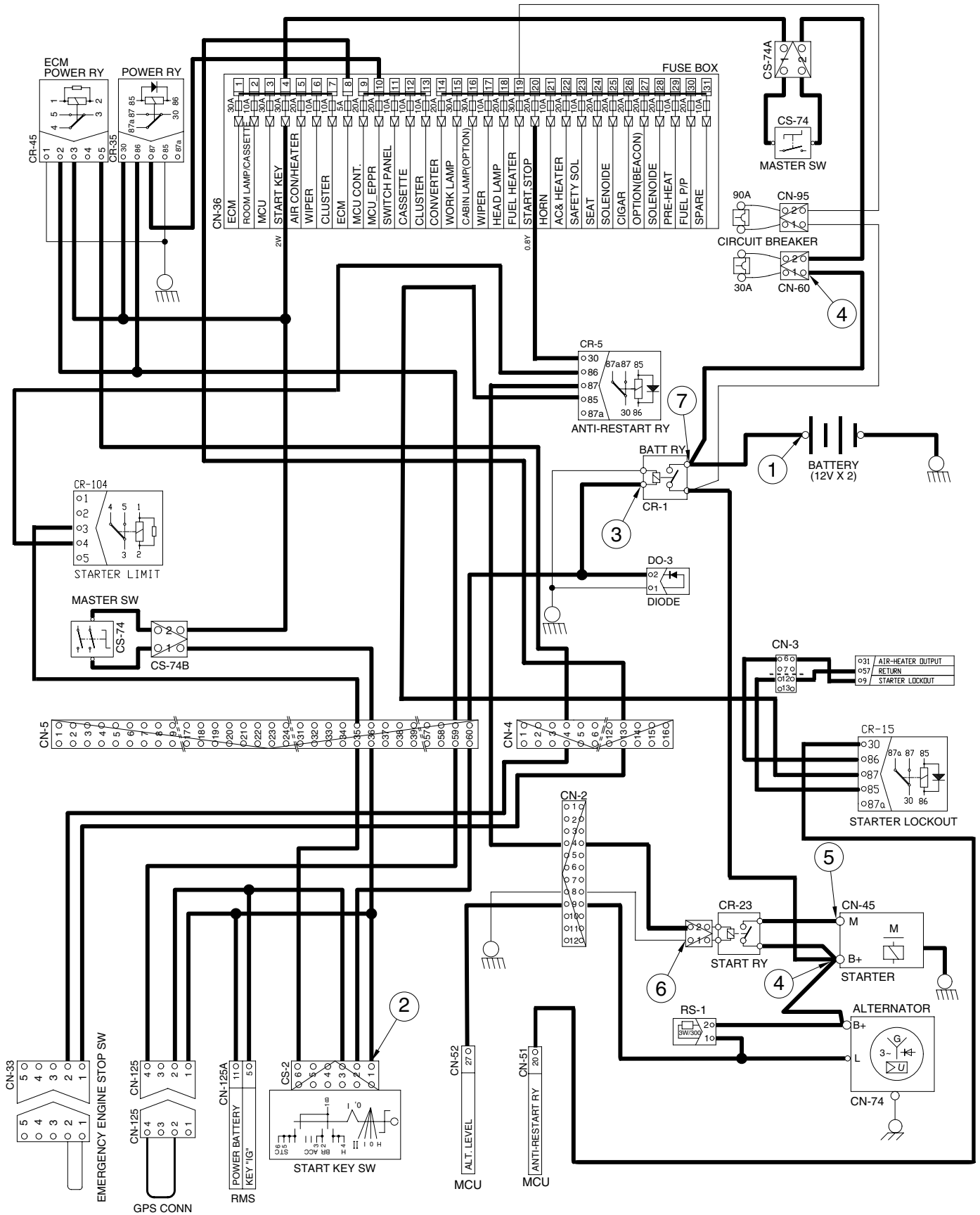

3. CHARGING CIRCUIT

When the starter is activated and the engine is started, the operator releases the key switch to the ON position.

Charging current generated by operating alternator flows into the battery through the battery relay [CR-1].

The current also flows from alternator to each electrical component and controller through the fuse box.

1) OPERATING FLOW

(1) Warning flow

Alternator "L" terminal → I/conn [CN-2 (9)] → MCU alternator level [CN-52 (27)]
 → Cluster charging warning lamp(Via serial interface)

(2) Charging flow

Alternator "B+" terminal → Battery relay(M8) → Battery(+) terminal
 → Fusible link [CN-60] → Master switch [CS-74]
 → Fuse box

2) CHECK POINT

Engine	Start switch	Check point	Voltage
Run	ON	① - GND (battery voltage) ② - GND (battery relay) ③ - GND (alternator B ⁺ terminal) ④ - GND (alternator L terminal) ⑤ - GND (MCU)	20~30V

※ GND : Ground

CHARGING CIRCUIT

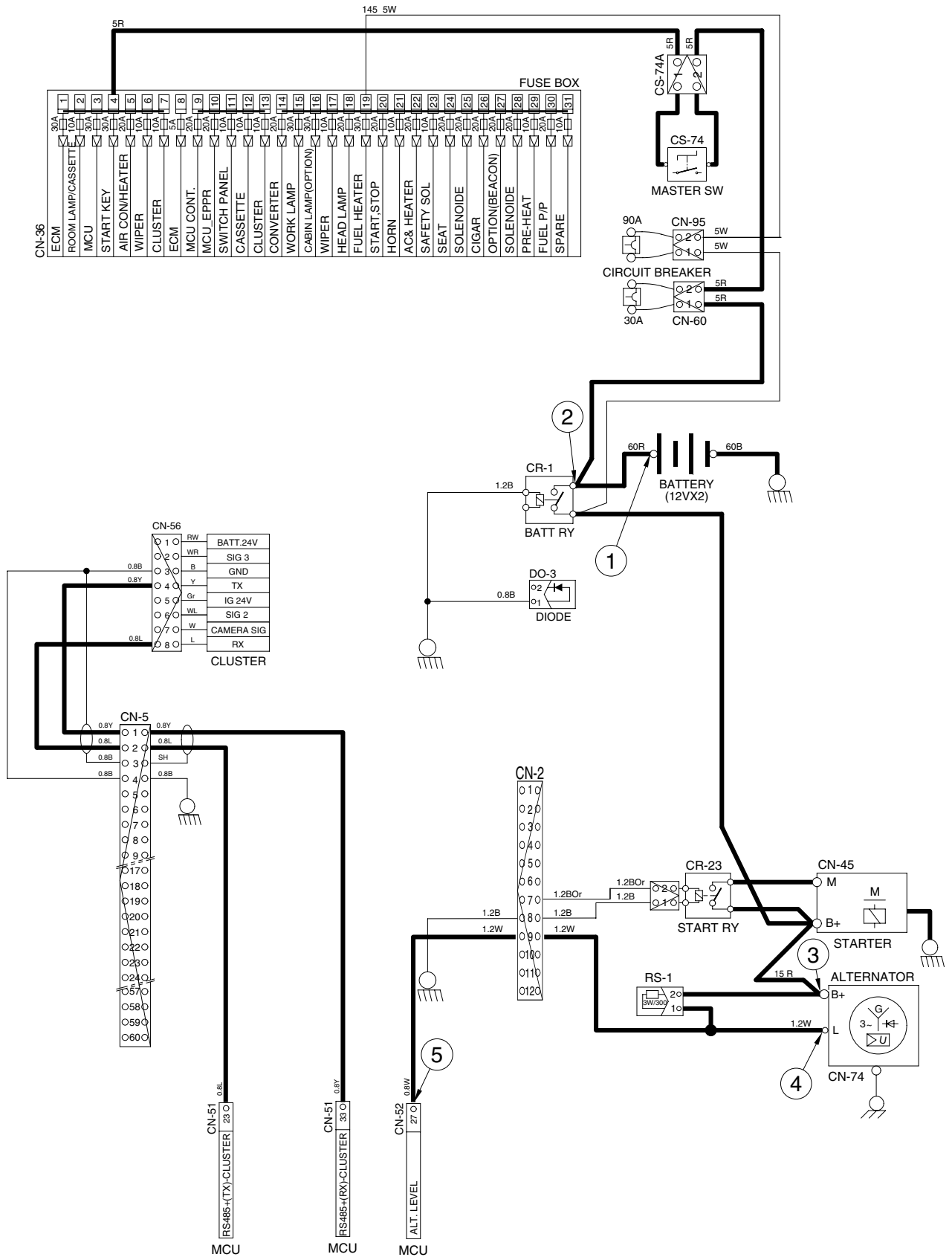

4. HEAD AND WORK LIGHT CIRCUIT

1) OPERATING FLOW

Fuse box (No.18) → Head light relay [CR-13 (30, 86)]

Fuse box (No.15) → Work light relay [CR-4 (30, 86)]

(1) Head light switch ON

Head light switch ON [CN-116 (1)] → I/conn [CN-5 (49)] → Head light relay [CR-13 (85) → (87)]

→ Head light ON [CL-3 (2) , [CL-4 (1)]

→ I/conn [CN-3(5)] → Head light [CL-24(2)]

→ I/conn [CN-8 (7)] → CN-279 [2]

→ I/conn [CN-5 (13)] → Cigar light [CL-2]

→ Radio [CN-27 (9)]

(2) Work light switch ON

Work light switch ON [CN-116 (2)] → I/conn [CN-5 (50)] → Work light relay [CR-4 (85) → (87)]

→ I/conn [CN-12 (1)] → Work light ON [CL-5 (2), CL-6 (2)]

2) CHECK POINT

Engine	Start switch	Check point	Voltage
STOP	ON	① - GND (fuse box) ② - GND (switch power output) ③ - GND (head light relay) ④ - GND (head light) ⑤ - GND (fuse box) ⑥ - GND (switch power output) ⑦ - GND (work light relay) ⑧ - GND (work light)	20~25V

※ GND : Ground

HEAD AND WORK LIGHT CIRCUIT

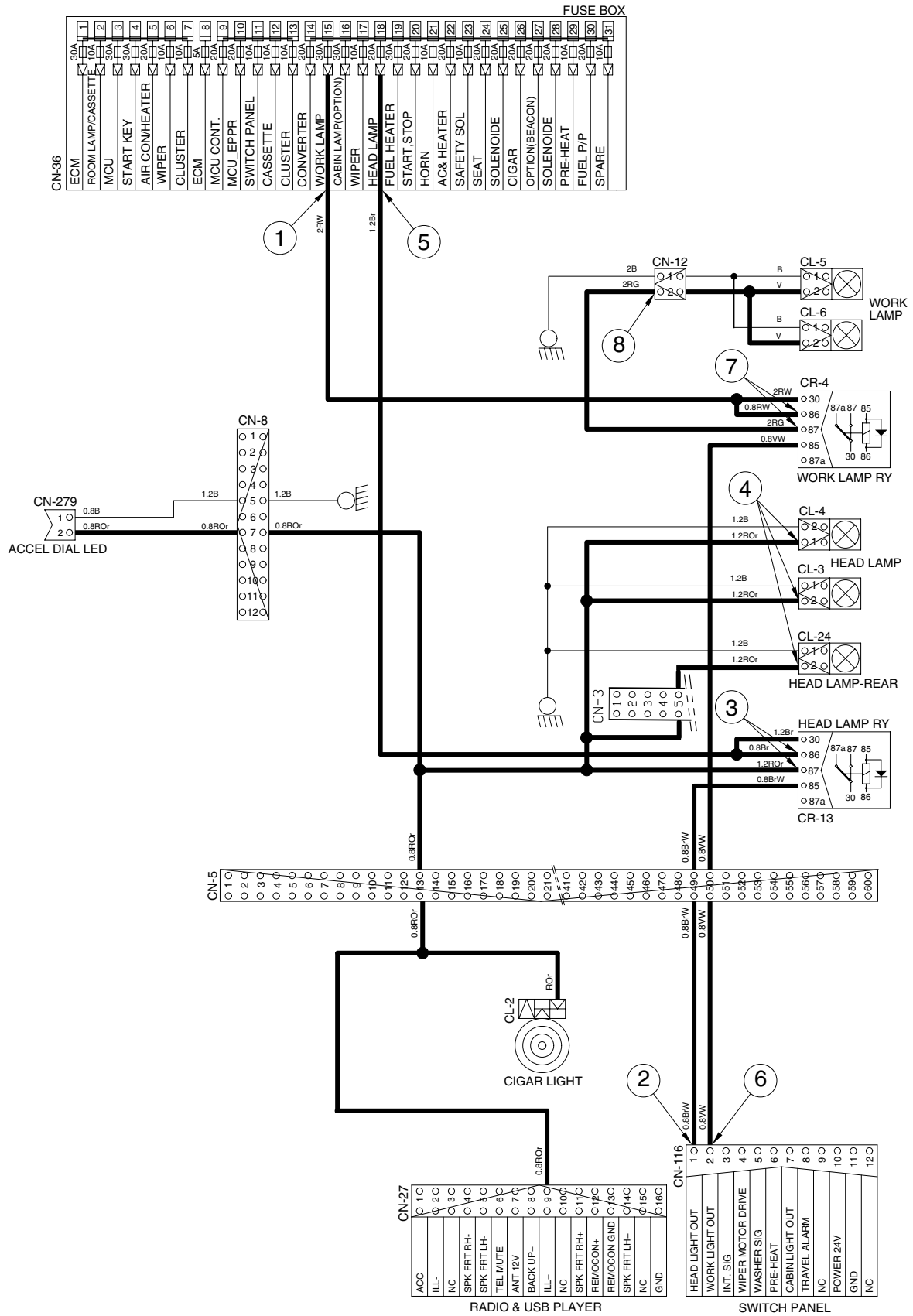

5. BEACON LAMP AND CAB LIGHT CIRCUIT

1) OPERATING FLOW

Fuse box (No.27) → I/conn [CN-5 (33)] → Beacon lamp switch [CN-23 (8)]

Fuse box (No.16) → Cab light relay [CR-9 (30, 86)]

(1) Beacon lamp switch ON

Beacon lamp switch ON [CS-23 (4)] → Switch indicator lamp ON [CS-23 (11)]
 → I/conn [CN-10 (10)] → Beacon lamp ON [CL-7]

(2) Cab light switch ON

Cab light switch ON [CN-116 (7)] → I/conn [CN-5 (55)] → Cabin lamp relay [CR-9 (85) → (87)]

→ I/conn [CN-5 (34, 38)] → I/conn [CN-10 (11)] → Cab light ON [CL-8 (2)]
 → I/conn [CN-10 (12)] → Cab light ON [CL-9 (2), CL-10(2)]

2) CHECK POINT

Engine	Start switch	Check point	Voltage
STOP	ON	① - GND (fuse box) ② - GND (switch power input) ③ - GND (switch power output) ④ - GND (beacon lamp) ⑤ - GND (fuse box) ⑥ - GND (cabin light relay) ⑦ - GND (switch power output) ⑧ - GND (cab light)	20~25V

※ GND : Ground

BEACON LAMP AND CAB LIGHT CIRCUIT

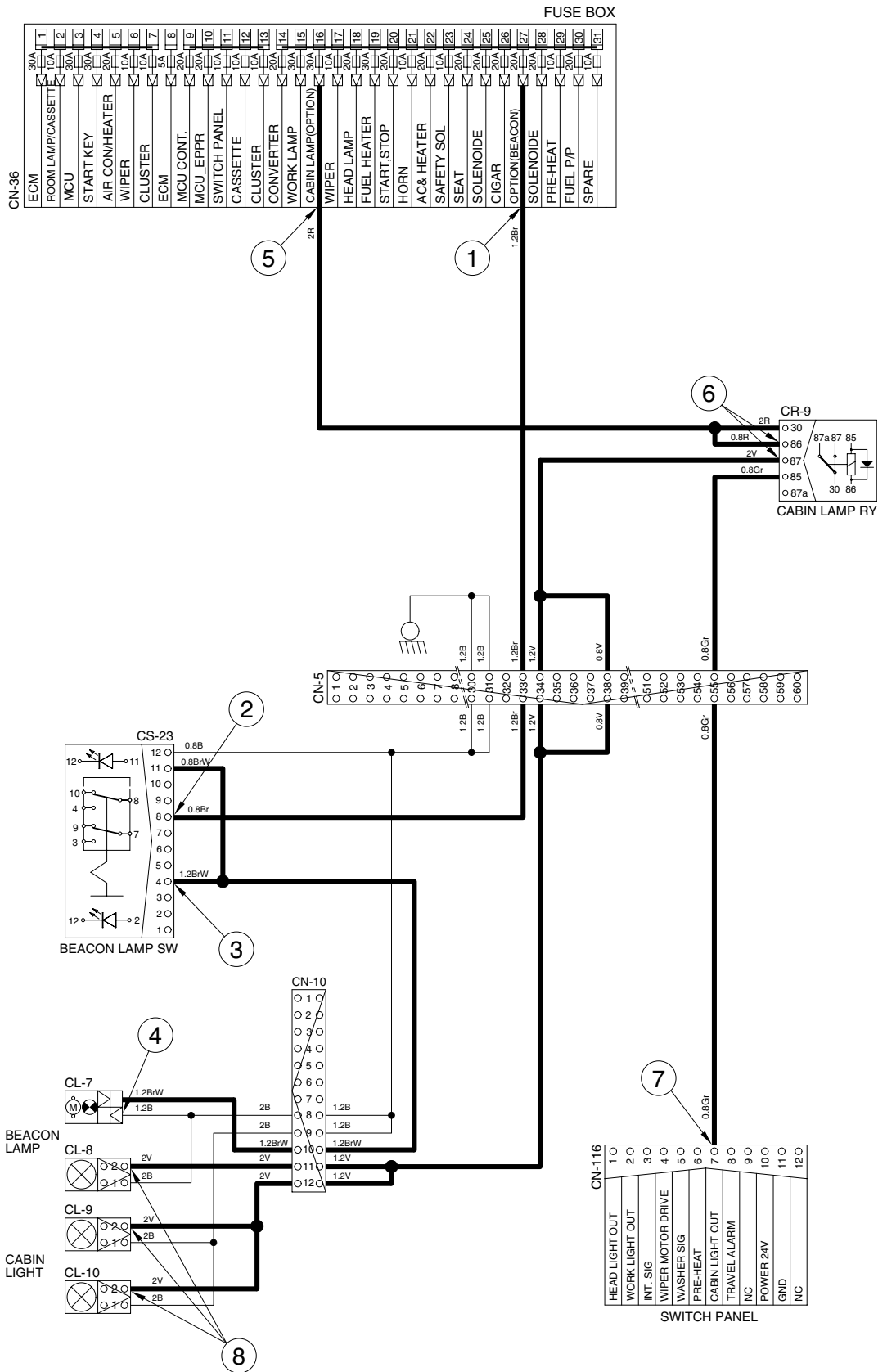

6. WIPER AND WASHER CIRCUIT

1) OPERATING FLOW

(1) Key switch ON

Fuse box (No.11) → I/conn [CN-5 (57)] → Switch panel [CN-116 (10)]

Fuse box (No.6) → I/conn [CN-5 (18)] → I/conn [CN-17 (5)] → Wiper motor controller [CN-141(7)]
 → Wiper motor [CN-21(6)]

Fuse box (No.17) → I/conn [CN-5 (24)] → I/conn [CN-17 (4)] → Wiper motor controller [CN-141 (6)]
 → Washer pump [CN-22 (2)]

(2) Wiper switch ON : 1st step (Intermittent)

Wiper switch ON [CN-116 (3)] → I/conn [CN-17 (8)] → Wiper motor controller [CN-141 (10) → (3)]
 → Wiper motor intermittently operating [CN-21(4)]

(3) Wiper switch ON : 2nd step (continual)

Wiper switch ON [CN-116(4)] → I/conn[CN-17(2)] → Wiper motor controller [CN-141(2) → (4)]
 → Wiper motor operating [CN-21(2)]

(4) Washer switch ON

Washer switch ON [CN-116 (5)] → I/conn [CN-17 (7)] → Wiper motor controller [CN-141 (9) → (8)]
 → I/conn [CN-17 (6)] → I/conn [CN-5 (19)] → Washer pump [CN-22 (1)] → Washer operating
 Wiper switch ON [CN-116 (4)] → I/conn[CN-17 (2)] → Wiper motor controller [CN-141 (2) → (4)]
 → Wiper motor operating [CN-21(2)]

(5) Auto parking (when switch OFF)

Switch OFF [CN-116 (4)] → Wiper motor parking position by wiper motor controller

2) CHECK POINT

Engine	Start switch	Check point	Voltage
STOP	ON	① - GND (fuse box)	24V
		② - GND (switch power input)	
		③ - GND (switch power output)	0 ~ 5V
		④ - GND (wiper power input)	
		⑤ - GND (wiper power output)	24V
		⑥ - GND (wiper motor)	0 or 24V

※ GND : Ground

WIPER AND WASHER CIRCUIT

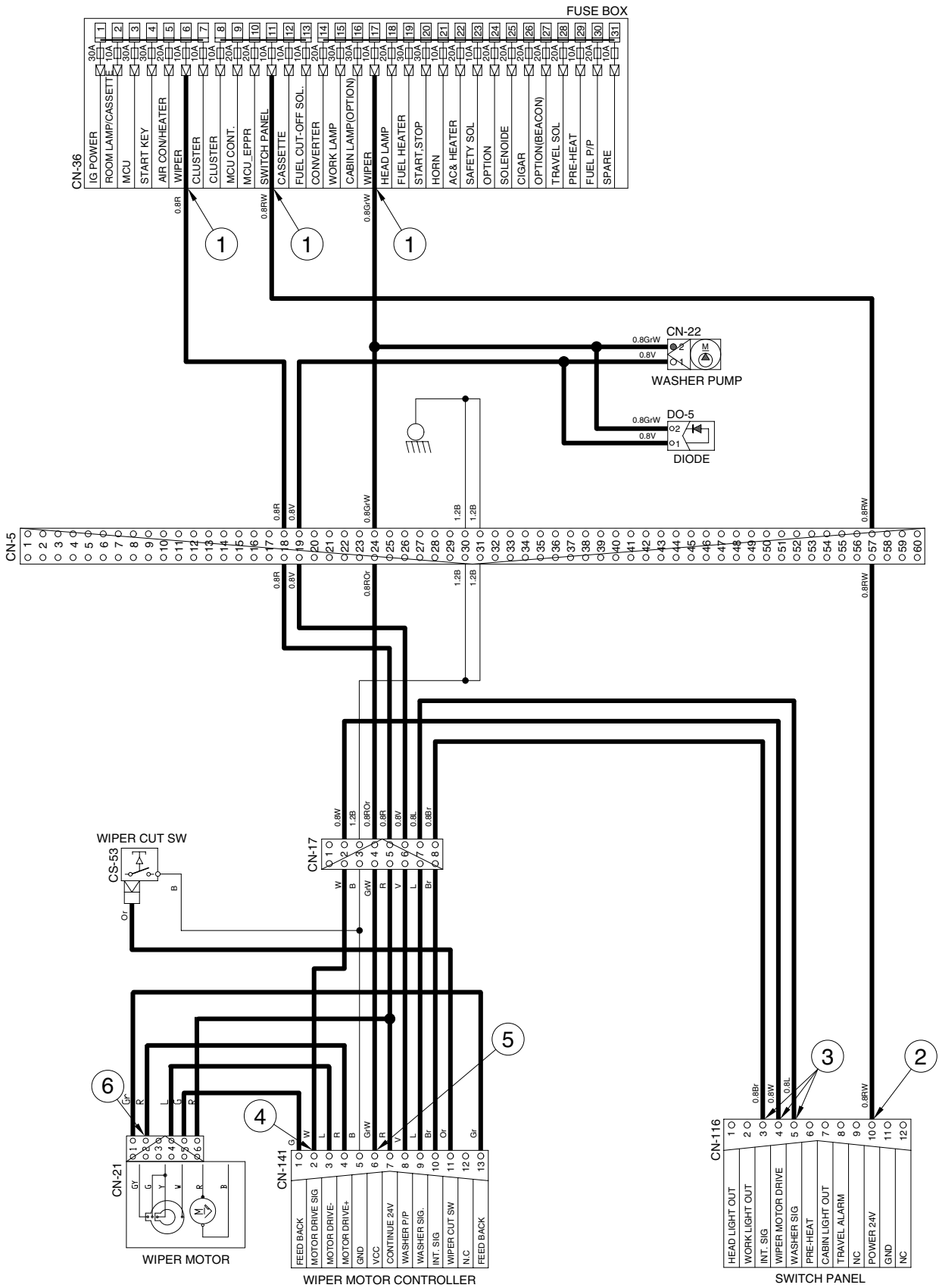

GROUP 3 ELECTRICAL COMPONENT SPECIFICATION

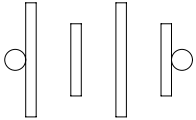
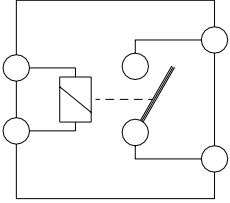
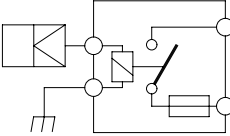
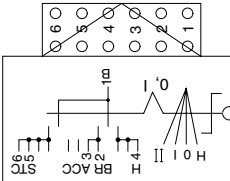
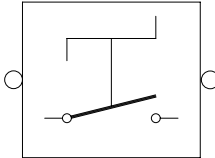
Part name	Symbol	Specifications	Check						
Battery		12V × 100Ah (2EA)	※ Check specific gravity 1.280 over : Over charged 1.280 ~ 1.250 : Normal 1.250 below : Recharging						
Battery relay	 <p style="text-align: center;">CR-1</p>	Rated load : 24V 100A (continuity) 1000A (30seconds)	※ Check coil resistance(M4 to M4) Normal : About 50 Ω ※ Check contact Normal : ∞ Ω						
Glow plug relay	 <p style="text-align: center;">CR-24</p>	24V 200A	※ Check contact Normal : 0.942 Ω (For terminal 1-GND)						
Start key	 <p style="text-align: center;">CS-2</p>	B-BR : 24V 1A B-ACC : 24V 10A B-ST : 24V 40A	※ Check contact OFF : ∞ Ω (for each terminal) ON : 0 Ω (for terminal 1-3 and 1-2) START : 0 Ω (for terminal 1-5)						
Pressure sensor	<table border="1" style="margin-left: auto; margin-right: auto;"> <tr> <td style="width: 20px; text-align: center;">○ A</td> <td style="width: 80px;">SUPPLY</td> </tr> <tr> <td style="text-align: center;">○ B</td> <td>SIG</td> </tr> <tr> <td style="text-align: center;">○ C</td> <td>RETURN</td> </tr> </table> <p style="text-align: center;"> CD-6 CD-7 CD-24 CD-31 CD-32 CD-35 CD-42 CD-43 CD-44 CD-70 CD-71 </p>	○ A	SUPPLY	○ B	SIG	○ C	RETURN	8~30V	※ Check contact Normal : 0.1 Ω
○ A	SUPPLY								
○ B	SIG								
○ C	RETURN								
Master switch	 <p style="text-align: center;">CS-74A CS-74B</p>	6-36V	※ Check disconnection Normal : 0.1 Ω						

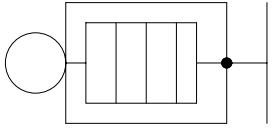
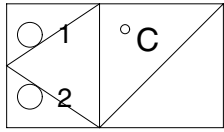
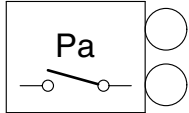
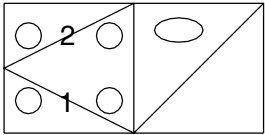
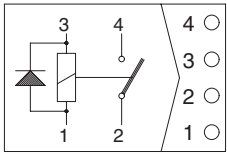
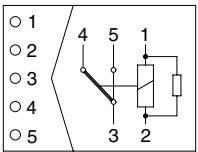
Part name	Symbol	Specifications	Check
Glow plug	 CN-80	24V 200A	※ Check resistance 0.25~0.12 Ω
Temperature sensor (hydraulic)	 CD-1	-	※ Check resistance 50°C : 804 Ω 80°C : 310 Ω 100°C : 180 Ω
Air cleaner pressure switch	 CD-10	-	※ Check contact High level : ∞ Ω Low level : 0 Ω
Fuel sender	 CD-2	-	※ Check resistance Full : 50 Ω 6/12 : 350 Ω 11/12 : 100 Ω 5/12 : 400 Ω 10/12 : 150 Ω 4/12 : 450 Ω 9/12 : 200 Ω 3/12 : 500 Ω 8/12 : 250 Ω 2/12 : 550 Ω 7/12 : 300 Ω 1/12 : 600 Ω Empty warning : 700 Ω
Relay (air con blower)		24V 20A	※ Check resistance Normal : About 200 Ω (for terminal 1-3) 0 Ω (for terminal 2-4)
Relay	 CR-2 CR-36 CR-45 CR-62	24V 16A	※ Check resistance Normal : About 160 Ω (for terminal 1-2) 0 Ω (for terminal 3-4) ∞ Ω (for terminal 3-5)

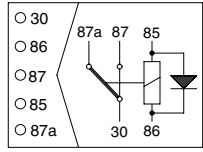
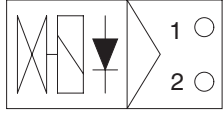
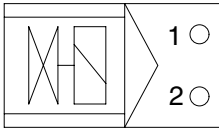
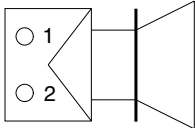
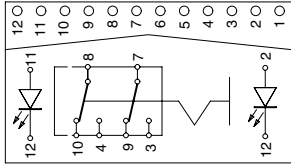
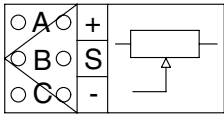
Part name	Symbol	Specifications	Check
Relay	 <p>CR-4 CR-5 CR-7 CR-9 CR-13 CR-15 CR-35 CR-46</p>	24V 16A	※ Check resistance Normal : About 160 Ω (for terminal 85-86) 0 Ω (for terminal 30-87a) ∞ Ω (for terminal 30-87)
Solenoid valve	 <p>CN-68 CN-66 CN-70 CN-88 CN-140 CN-149 CN-236 CN-237</p>	24V 1A	※ Check resistance Normal : 15~25 Ω (for terminal 1-2)
EPPR valve	 <p>CN-75 CN-133 CN-242</p>	700mA	※ Check resistance Normal : 15~25 Ω (for terminal 1-2)
Speaker	 <p>CN-23(LH) CN-24(RH)</p>	20W	※ Check resistance Normal : A few Ω
Switch (locking type)	 <p>CS-23 CS-50 CS-52 CS-67 CS-73 CS-82 CS-83 CS-99 CS-100</p>	24V 8A	※ Check contact Normal ON : 0 Ω (for terminal 3-7, 4-8) ∞ Ω (for terminal 7-9, 8-10) OFF : ∞ Ω (for terminal 3-7, 4-8) 0 Ω (for terminal 7-9, 8-10)
Accel dial	 <p>CN-142</p>	-	※ Check resist Normal : About 5k Ω (for terminal A-C) ※ Check voltage Normal : About 5V (for terminal A-C) : 2~4.5V (for terminal C-B)

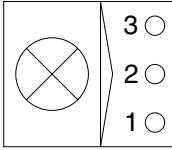
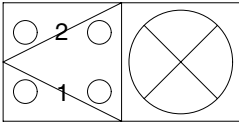
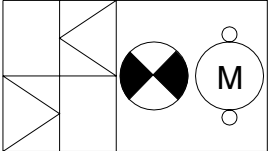
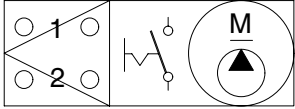
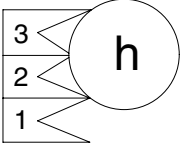
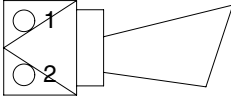
Part name	Symbol	Specifications	Check
Room lamp	 <p>CL-1</p>	24V 10W	※ Check disconnection Normal : 1.0 Ω ON : 0 Ω (For terminal 1-2) ∞ Ω (For terminal 1-3) OFF : ∞ Ω (For terminal 1-2) 0 Ω (For terminal 1-3)
Head lamp, Work lamp, Cab lamp	 <p>CL-3 CL-4 CL-5 CL-6 CL-7 CL-8 CL-9 CL-10 CL-24</p>	24V 65W (H3 Type)	※ Check disconnection Normal : 1.2 Ω
Beacon lamp	 <p>CL-7</p>	21V 70W (H1 Type)	※ Check disconnection Normal : A few Ω
Fuel filler pump	 <p>CN-61</p>	24V 10A 35 l /min	※ Check resistance Normal : 1.0 Ω
Service meter	 <p>CN-48</p>	16~32V	※ Check operation Supply power(24V) to terminal No.2 and connect terminal No.1 and ground
Horn	 <p>CN-20 CN-25</p>	DC22~28V 2A	※ Check operation Supply power(24V) to each terminal and connect ground.

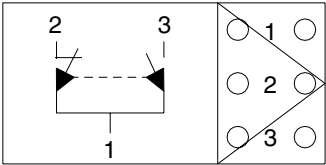
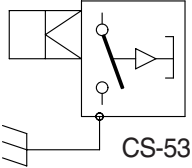
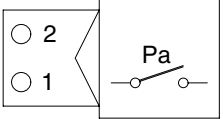
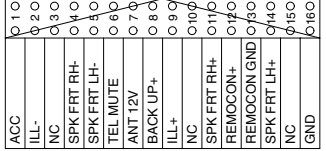
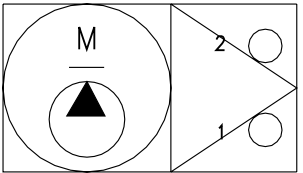
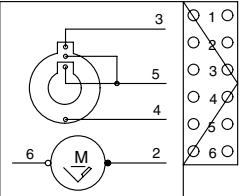
Part name	Symbol	Specifications	Check
Safety switch	 <p>CS-4</p>	24V 15A (N.C TYPE)	※ Check contact Normal : 0 Ω (for terminal 1-2) ∞ Ω (for terminal 1-3) Operating : ∞ Ω (for terminal 1-2) 0 Ω (for terminal 1-3)
Wiper cut switch	 <p>CS-53</p>	24V (N.O TYPE)	※ Check contact Normal : 0 Ω (one pin to ground)
Receiver dryer	 <p>CN-29</p>	24V 2.5A	※ Check contact Normal : ∞ Ω
Radio & USB player	 <p>CN-27</p>	24V 2A	※ Check voltage 20~25V (for terminal 1-3, 3-8)
Washer pump	 <p>CN-22</p>	24V 3.8A	※ Check contact Normal : 10.7 Ω (for terminal 1-2)
Wiper motor	 <p>CN-21</p>	24V 2A	※ Check disconnection Normal : 7 Ω (for terminal 2-6)

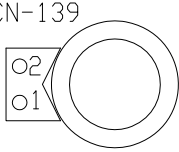
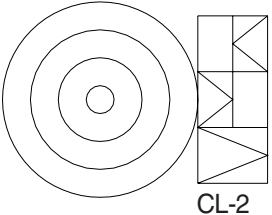
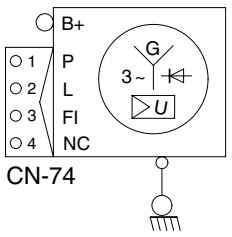
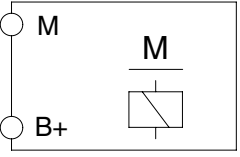
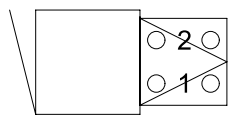
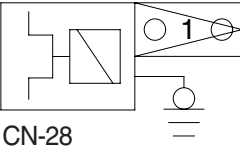
Part name	Symbol	Specifications	Check
SOCKET USB	 <p>CN-139</p>	—	—
Cigar lighter	 <p>CL-2</p>	24V 5A 1.4W	※ Check coil resistance Normal : About 1M Ω ※ Check contact Normal : ∞ Ω Operating time : 5~15sec
Alternator	 <p>CN-74</p>	24V 50A	※ Check contact Normal : 0 Ω (for terminal B ⁺ -I) Normal : 24~27.5V
Starter	 <p>CN-45</p>	Denso 24V 4.5kW	※ Check contact Normal : 0.1 Ω
Travel alarm	 <p>CN-81</p>	24V 0.5A	※ Check contact Normal : 5.2 Ω
Aircon compressor	 <p>CN-28</p>	24V 79W	※ Check contact Normal : 13.4 Ω

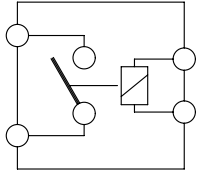
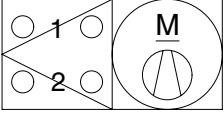
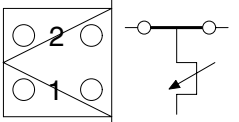
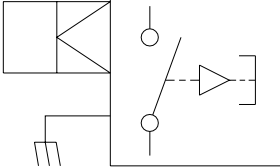
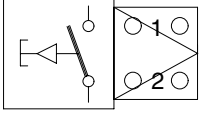
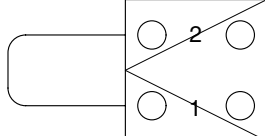
Part name	Symbol	Specifications	Check
Start relay	 <p>CR-23</p>	24V 300A	※ Check contact Normal : 0.94 Ω (for terminal 1-2)
Blower motor		24V 9.5A	※ Check resistance Normal : 2.5 Ω (for terminal 1-2)
Duct sensor (switch)		1°C OFF 4°C ON	※ Check resistance Normal : 0 Ω (for terminal 1-2), the atmosphere temp : Over 4°C
Door switch	 <p>CS-1</p>	24V 2W	※ Check resistance Normal : About 5M Ω
Switch (power max, one touch decal, horn, breaker)	 <p>CS-5 CS-19 CS-26 CS-29</p>	24V 6A	※ Check resistance Normal : ∞ Ω
Fusible link (cluster type 2)	 <p>CN-60 CN-95</p>	60A	※ Check disconnection normal : 0 Ω (connect ring terminal and check resist between terminal 1 and 2)

GROUP 4 CONNECTORS

1. CONNECTOR DESTINATION

Connector number	Type	No. of pin	Destination	Connector part No.	
				Female	Male
CN-1	AMP	10	I/conn (Frame harness-Pump PS harness)	S816-006002	S816-106002
CN-2	AMP	12	I/conn (Frame harness-Engine harness)	2-85262-1	368301-1
CN-3	AMP	15	I/conn (Frame harness-Engine harness)	S816-012002	S816-112002
CN-4	AMP	16	I/conn (Console harness LH-Frame harness)	368047-1	368050-1
CN-5	DEUTSCH	60	I/conn (Side harness RH-Frame harness)	DRB16-60SAE-L018	DRB14-60PAE-L018
CN-7	AMP	16	I/conn (Console harness RH-Frame harness)	368047-1	368050-1
CN-8	AMP	12	I/conn (Console harness RH-Frame harness)	S816-012002	S816-112002
CN-10	DEUTSCH	12	I/conn (Cab harness-Side harness RH)	DT06-12S-EP06	DT04-12P-BE02
CN-11	DEUTSCH	8	I/conn (Frame harness-Aircon harness)	DT06-8S	-
CN-12	DEUTSCH	2	I/conn (Frame harness-Boom wire harness)	DT06-2S-EP06	DT04-2P-E005
CN-15	AMP	12	I/conn (Frame harness-attech harness)	S816-012002	S816-112002
CN-16	AMP	6	I/conn (Accel dial harness)	S816-008002	S816-108002
CN-17	AMP	8	I/conn (Wiper harness)	S816-008002	S816-108002
CN-20	MOLEX	2	Horn	36825-0211	-
CN-21	AMP	6	Wiper motor	925276-0	-
CN-22	KET	2	Washer pump	MG640605	-
CN-23	KET	2	Speaker-LH	MG610070	-
CN-24	KET	2	Speaker-RH	MG610070	-
CN-25	MOLEX	2	Horn	36825-0211	-
CN-27	KUM	16	Cassette radio	PK145-16017	-
CN-28	KUM	1	Aircon compressor	MWP-01F-B	-
CN-29	KET	2	Receiver dryer	MG640795	-
CN-36	-	-	Fuse & relay box	21Q7-10910	-
CN-45	RING-TERM	-	Starter motor B+	S820-308000	DT04-4P-E005
CN-48	KET	3	Service meter	2-520193-2	-
CN-51	DEUTSCH	40	MCU (cluster type 1)	DRC26-40SA	-
CN-52	DEUTSCH	40	MCU (cluster type 1)	DRC26-40SB	-
CN-55	-	-	Fuse(2A)	-	-
CN-56	AMP	8	Cluster (type 1)	-	S816-108002
CN-60	AMP	2	Fusible link	21N4-01320	S813-130201
CN-61	DEUTSCH	2	Fuel filler pump	DT06-2S-EP06	-
CN-66	DEUTSCH	2	Breaker solenoid	DT06-2S-EP06	DT04-2P-EP005
CN-68	DEUTSCH	2	Safety solenoid	DT06-2S	-

Connector number	Type	No. of pin	Destination	Connector part No.	
				Female	Male
CN-70	DEUTSCH	2	Travel high solenoid	DT06-2S	-
CN-74	AMP	4	Alternator "L" terminal	12186568	-
CN-75	AMP	2	Pump EPPR	S816-002002	-
CN-80	RING-TERM	-	Glow plug	S820-306000	-
CN-81	DEUTSCH	2	Travel buzzer	DT06-2S-EP06	-
CN-88	DEUTSCH	2	Power max solenoid	DT06-2S-EP06	-
CN-95	YAZAKI	2	Fusible link	21N4-01311	7122-4125-50
CN-113	KET	2	Buzzer MG651205-5	-	
CN-116	AMP	12	Switch panel	176116	-
CN-125	DEUTSCH	4	GPS CONN	-	
CN-125A	AMP	12	RMS	-	
CN-126	AMP	10	Service tool	S816-010002	S816-110002
CN-133	DEUTSCH	2	Boom priority solenoid	DT06-2S-EP06	-
CN-139	AMP	2	12V socket	172434-2	-
CN-140	DEUTSCH	2	Quick clamp solenoid	DT06-2S-EP06	DT04-2P-E005
CN-141	AMP	13	Wiper motor controller	172498-1	DT04-3P-EP10
CN-142	DEUTSCH	3	Accel dial	DT06-3S-EP06	-
CN-144	AMP	4	Free harness	2-967325-3	
CN-147	AMP	4	Fuel warmer	2-967325-3	-
CN-149	DEUTSCH	2	Attach safety solenoid	DT06-2S-EP06	-
CN-156	DEUTSCH	2	Air seat	-	DT04-2P-E005
CN-173	DEUTSCH	2	Resister	-	DT04-2P-E005
CN-236	DEUTSCH	2	Attach pressure solenoid	DT06-2S-EP06	-
CN-237	DEUTSCH	2	Attach conflux solenoid	DT06-2S-EP06	-
CN-242	DEUTSCH	2	Attach flow solenoid	DT06-2S-EP06	DT04-2P-E005
CN-249	AMP	4	Rear view camera	S816-004002	S816-104002
CN-259	DEUTSCH	6	Camera	DT06-08SA-EP06	DT04-8P
CN-279	AMP	2	Accel dial LED	S816-002002	-
· Relay					
CR-1	RING-TERM	-	Battery relay	ST730135-2	-
CR-2	-	5	Horn relay	-	-
CR-4	-	5	Work lamp relay	-	-
CR-5	-	5	Anti restart relay	-	-
CR-7	-	5	Aircon compressor relay	-	-
CR-9	-	5	Cabin lamp relay	-	-
CR-13	-	5	Head lamp relay	-	-
CR-15	-	5	Starter lockout relay	-	-
CR-23	AMP	4	Start relay	-	S814-102001

Connector number	Type	No. of pin	Destination	Connector part No.	
				Female	Male
CR-24	AMP	4	Preheat relay	S822-014000	-
CR-35	-	5	Power relay	-	-
CR-36	-	5	Preheat relay	-	-
CR-46	-	5	Fuel warmer relay	-	-
CR-62	-	5	Breaker relay	-	-
CR-104		5	Starter limit relay	-	-
· Switch					
CS-1	SHUR	1	Door switch	S822-014002	S822-114002
CS-2	WP	6	Start key switch	S814-006100	-
CS-4	DEUTSCH	3	Safety switch	DT06-3S-EP06	-
CS-5	DEUTSCH	2	Horn switch	-	DT04-2P-E005
CS-19	DEUTSCH	2	One touch decel switch	-	DT04-2P-E005
CS-23	SWF	12	Beacon lamp switch	SWF589790	-
CS-26	DEUTSCH	2	Breaker switch	DT06-2S-EP06	-
CS-26A	AMP	2	Breaker foot pedal	S816-002002	S816-102002
CS-29	DEUTSCH	2	Power max switch	DT06-2S-EP06	-
CS-33	AMP	6	Emergency engine stop switch	S816-006002	S816-106002
CS-50	SWF	12	Overload switch	SWF589790	-
CS-53	AMP	1	Wiper cut switch	S822-014002	-
CS-67	SWF	12	Quick clamp switch	SWF 589790	-
CS-74A	AMP	2	Master switch	S813-030201	-
CS-74B	DEUTSCH	2	Master switch	DT06-2S-EP06	-
CS-82	SWF	12	Spare switch	SWF 589790	-
CS-83	SWF	12	Crab switch	SWF589790	-
CS-99	SWF	12	Air comp switch	SWF 589790	-
CS-100	SWF	12	Spare switch	SWF 589790	-
· Light					
CL-1	KET	3	Room lamp	MG651032	-
CL-2	AMP	3	Cigar light	S822-014002	S822-114002
CL-3	DEUTSCH	2	Head lamp-LH	DT06-2S-EP06	DT04-2P-E005
CL-4	DEUTSCH	2	Head lamp-RH	DT06-2S-EP06	DT04-2P-E005
CL-5	AMP	2	Work lamp-LH	180923-0	-
CL-6	AMP	2	Work lamp-RH	180923-0	-
CL-7	SHUR	2	Beacon lamp	S822-014002	S822-114002
CL-8	DEUTSCH	2	Cab light-LH	DT06-2S-EP06	DT-2P
CL-9	DEUTSCH	2	Cab light-RH	DT06-2S-EP06	DT04-2P
CL-10	DEUTSCH	2	Cab light-RH	DT06-2S-EP06	DT04-2P

Connector number	Type	No. of pin	Destination	Connector part No.	
				Female	Male
· Sensor, sender					
CD-1	AMP	2	Hydraulic oil temp sender	85202-1	-
CD-2	DEUTSCH	2	Fuel level sender	DT06-2S-EP06	-
CD-6	DEUTSCH	3	Travel pressure sensor	DT06-3S-EP06	-
CD-7	DEUTSCH	3	Working pressure sensor	DT06-3S-EP06	-
CD-10	RING TERM	-	Air cleaner switch	ST730135-2	-
CD-24	DEUTSCH	3	Swing sensor	DT06-3S-EP06	-
CD-31	AMP	3	Overload sensor	S816-003002	S816-103002
CD-32	DEUTSCH	3	Boom up sensor	DT06-3S-EP06	-
CD-42	DEUTSCH	3	Pump pressure 1	DT06-3S-EP06	-
CD-43	DEUTSCH	3	Pump pressure 2	DT06-3S-EP06	-
CD-44	DEUTSCH	3	Eppr pressure	DT06-3S-EP06	-
CD-45	DEUTSCH	2	Wif sensor	DT06-3S-EP06	-
CD-69	DEUTSCH	3	Attach pressure sensor	DT06-3S-EP06	-
CD-70	DEUTSCH	3	N1 pressure	DT06-3S-EP06	-
CD-71	DEUTSCH	3	N2 pressure	DT06-3S-EP06	-

2. CONNECTION TABLE FOR CONNECTORS

1) PA TYPE CONNECTOR

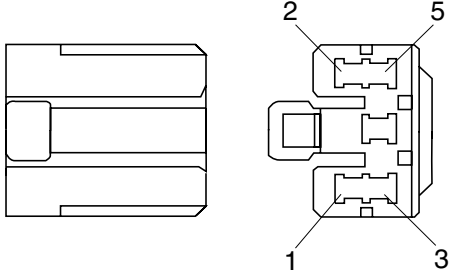
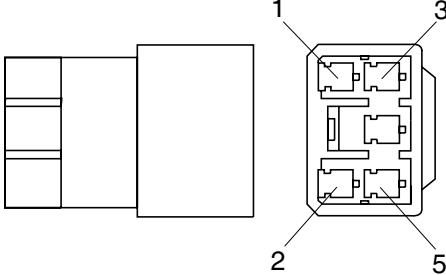
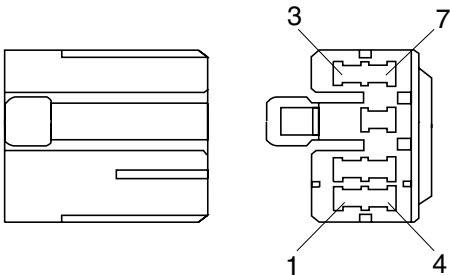
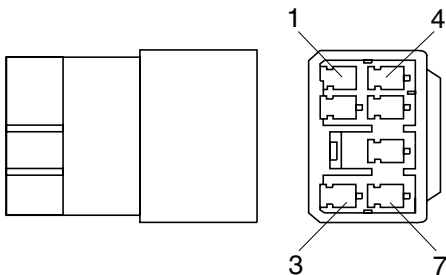
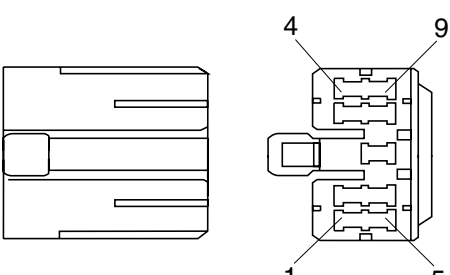
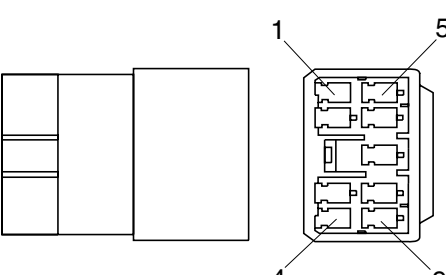
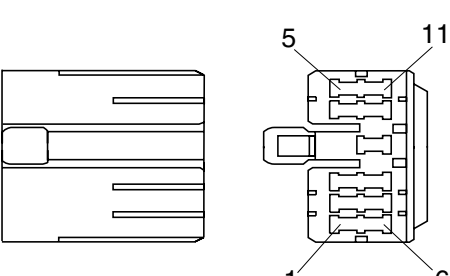
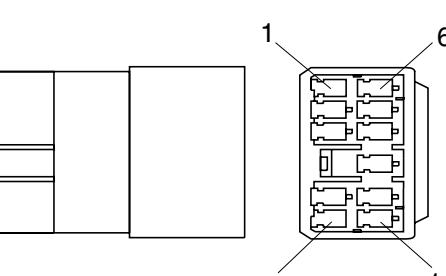
No. of pin	Receptacle connector (female)	Plug connector (male)
5	 <p style="text-align: center;">S811-005002</p>	 <p style="text-align: center;">S811-105002</p>
7	 <p style="text-align: center;">S811-007002</p>	 <p style="text-align: center;">S811-107002</p>
9	 <p style="text-align: center;">S811-009002</p>	 <p style="text-align: center;">3S811-109002</p>
11	 <p style="text-align: center;">S811-011002</p>	 <p style="text-align: center;">S811-111002</p>

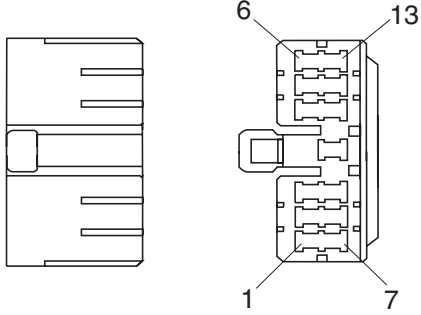
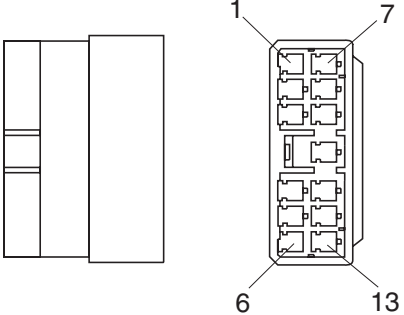
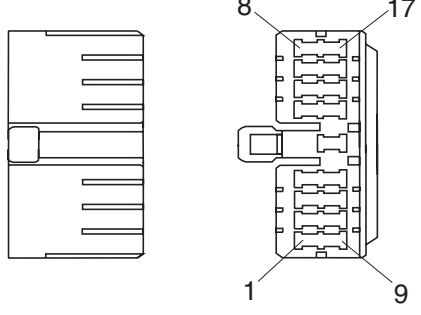
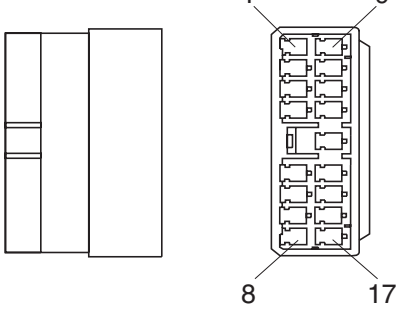
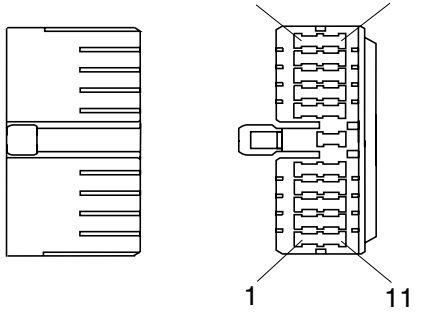
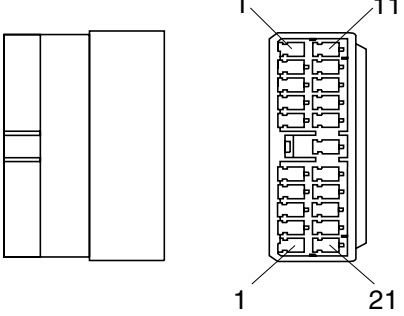
No. of pin	Receptacle connector (female)	Plug connector (male)
13	 <p style="text-align: center;">S811-013002</p>	 <p style="text-align: center;">S811-113002</p>
17	 <p style="text-align: center;">S811-017002</p>	 <p style="text-align: center;">S811-117002</p>
21	 <p style="text-align: center;">S811-021002</p>	 <p style="text-align: center;">S811-121002</p>

2) J TYPE CONNECTOR

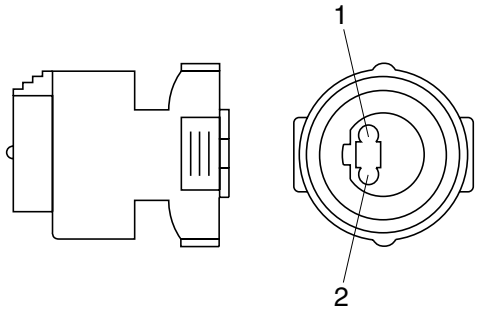
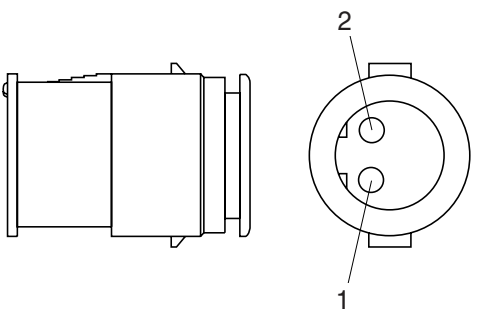
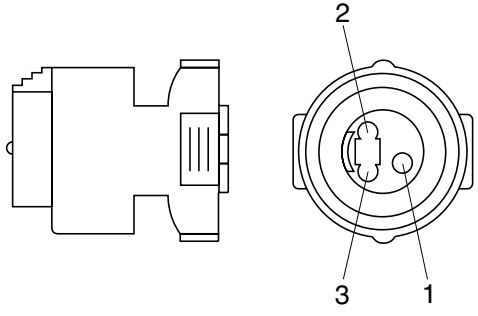
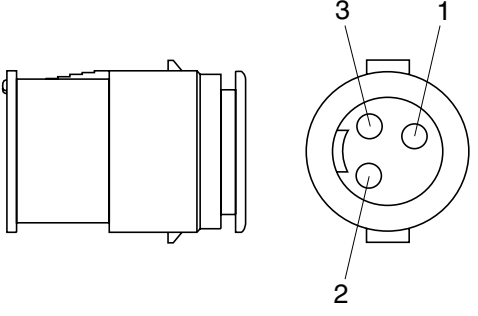
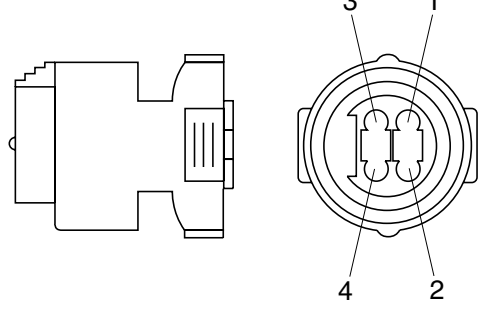
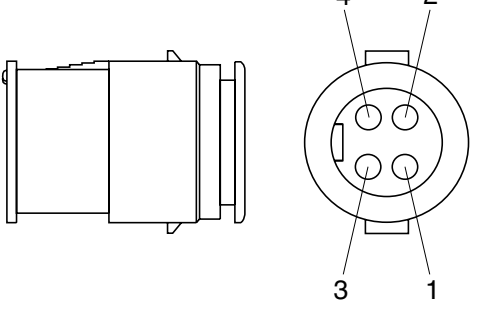
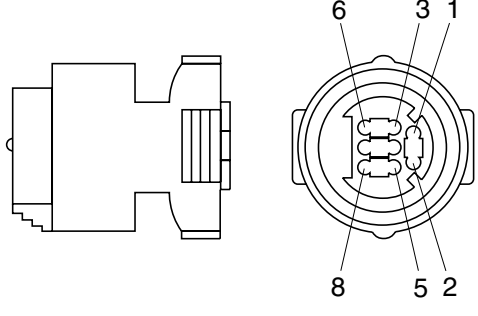
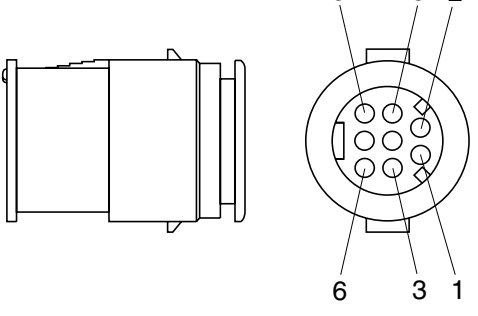
No. of pin	Receptacle connector (female)	Plug connector (male)
2	 <p style="text-align: center;">S816-002001</p>	 <p style="text-align: center;">S816-102001</p>
3	 <p style="text-align: center;">S816-003001</p>	 <p style="text-align: center;">S816-103001</p>
4	 <p style="text-align: center;">S816-004001</p>	 <p style="text-align: center;">S816-104001</p>
8	 <p style="text-align: center;">S816-008001</p>	 <p style="text-align: center;">S816-108001</p>

3) SWP TYPE CONNECTOR

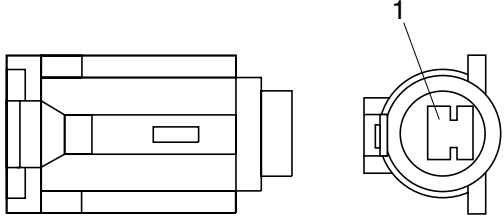
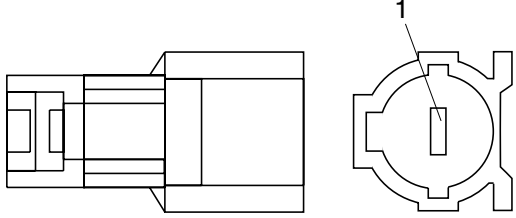
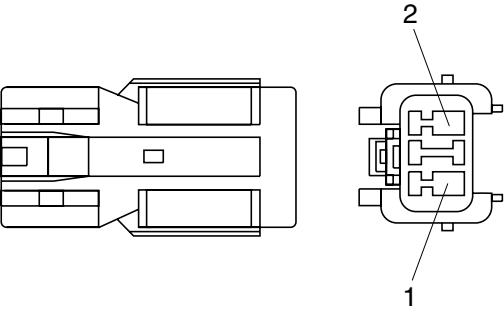
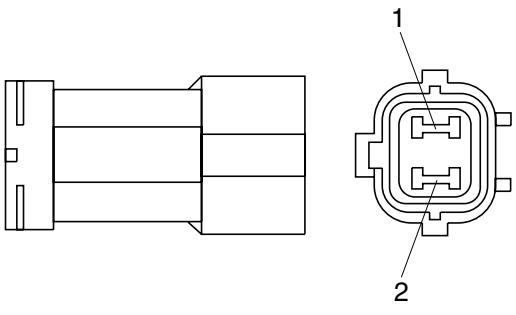
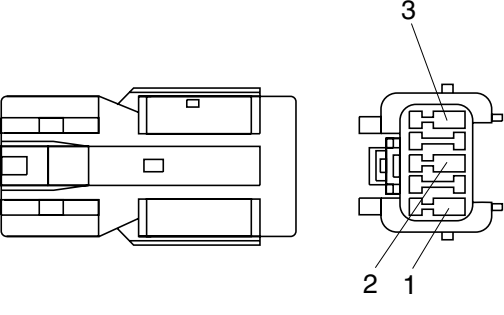
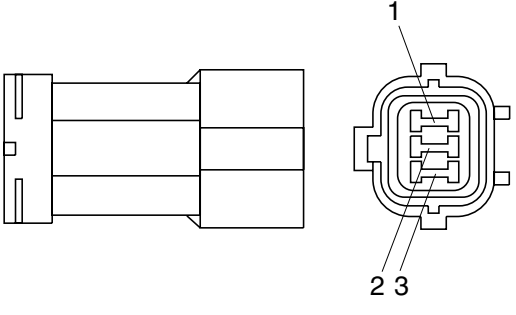
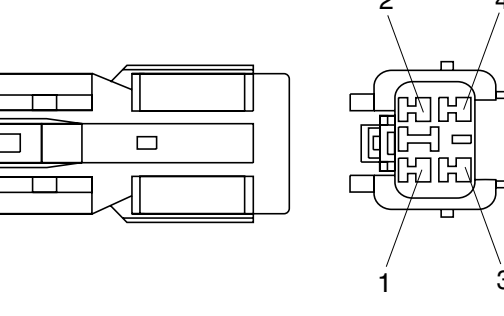
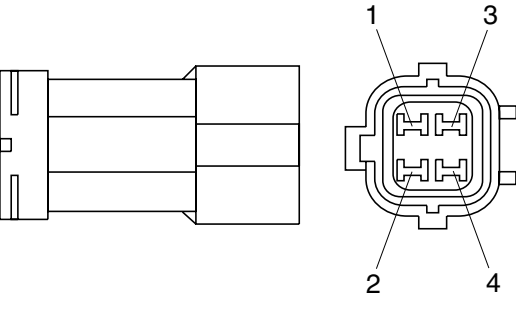
No. of pin	Receptacle connector (female)	Plug connector (male)
1	 <p data-bbox="687 685 839 712">S814-001000</p>	 <p data-bbox="1241 685 1393 712">S814-101000</p>
2	 <p data-bbox="687 1088 839 1115">S814-002000</p>	 <p data-bbox="1241 1088 1393 1115">S814-102000</p>
3	 <p data-bbox="687 1498 839 1525">S814-003000</p>	 <p data-bbox="1241 1498 1393 1525">S814-103000</p>
4	 <p data-bbox="687 1908 839 1935">S814-004000</p>	 <p data-bbox="1241 1908 1393 1935">S814-104000</p>

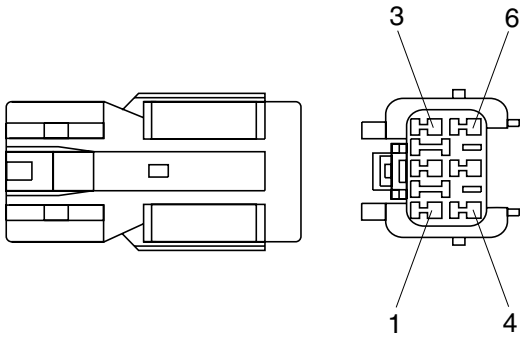
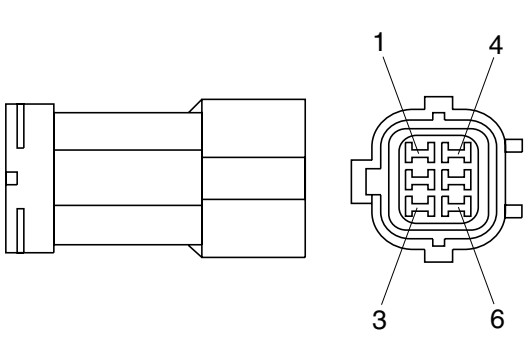
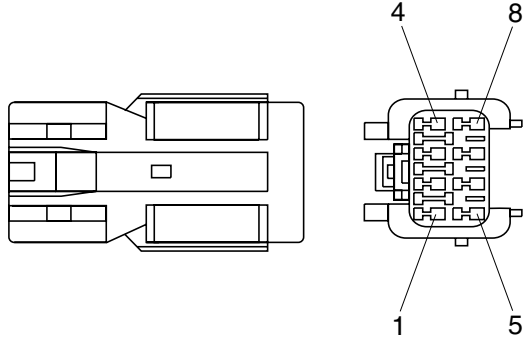
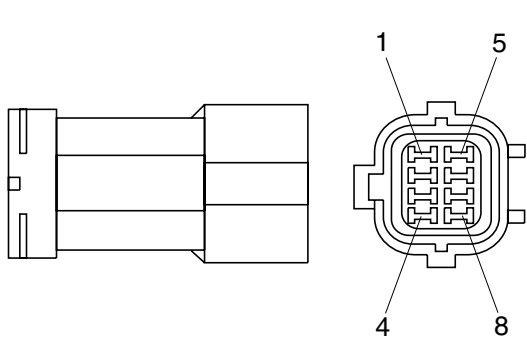
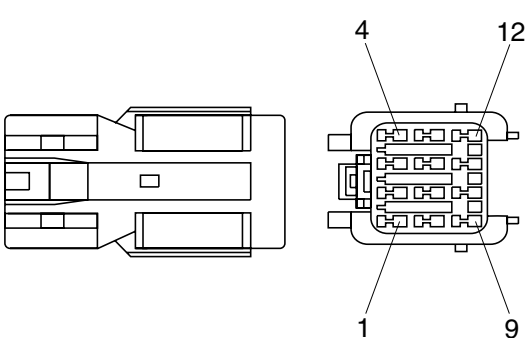
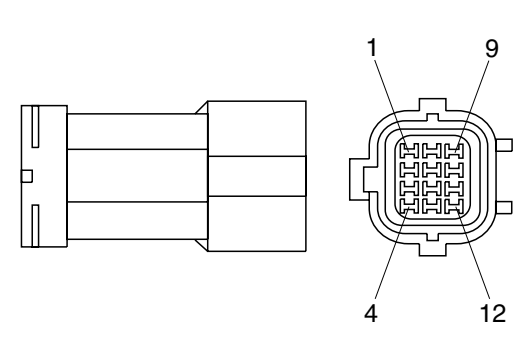
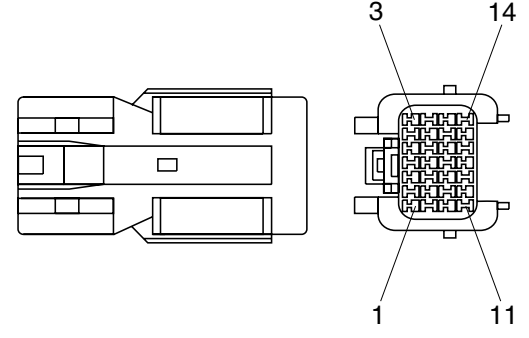
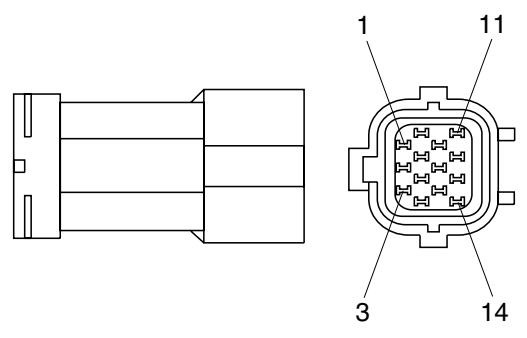
No. of pin	Receptacle connector (female)	Plug connector (male)
6	 <p data-bbox="686 638 837 672">S814-006000</p>	 <p data-bbox="1236 638 1388 672">S814-106000</p>
8	 <p data-bbox="686 1048 837 1081">S814-008000</p>	 <p data-bbox="1236 1048 1388 1081">S814-108000</p>
12	 <p data-bbox="686 1458 837 1491">S814-012000</p>	 <p data-bbox="1236 1458 1388 1491">S814-112000</p>
14	 <p data-bbox="686 1868 837 1901">S814-014000</p>	 <p data-bbox="1236 1868 1388 1901">S814-114000</p>

4) CN TYPE CONNECTOR

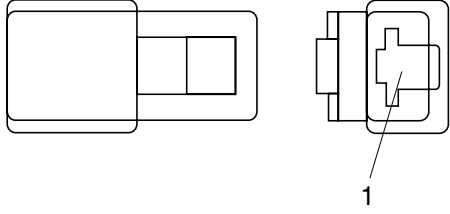
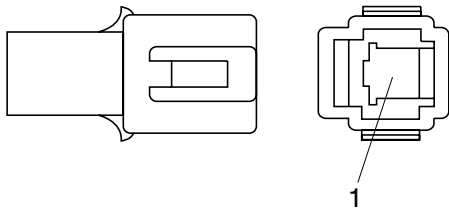
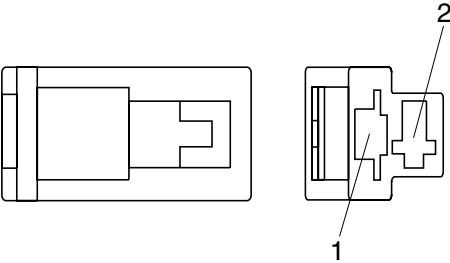
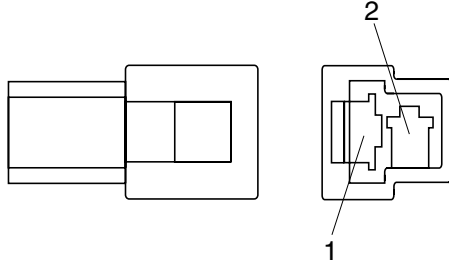
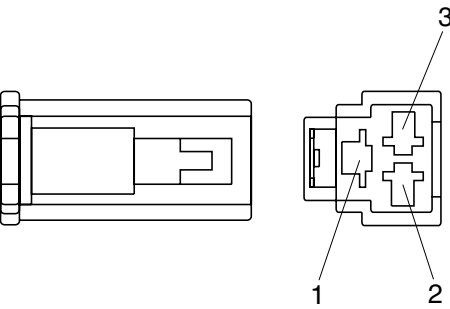
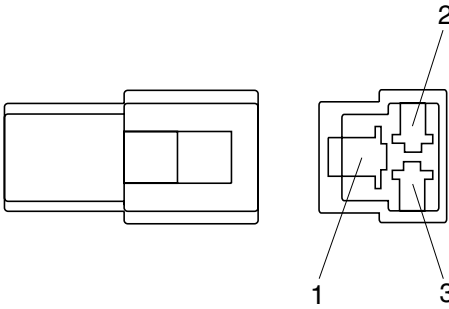
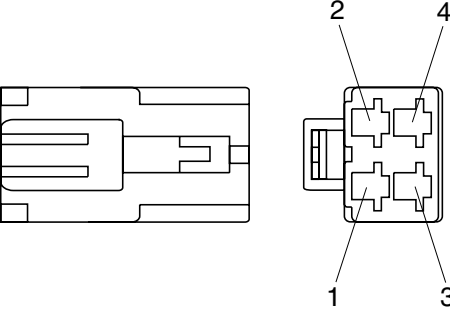
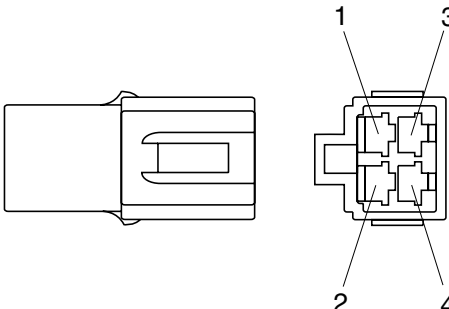
No. of pin	Receptacle connector (female)	Plug connector (male)
1	 <p style="text-align: center;">S810-001202</p>	 <p style="text-align: center;">S810-101202</p>
2	 <p style="text-align: center;">S810-002202</p>	 <p style="text-align: center;">S810-102202</p>
3	 <p style="text-align: center;">S810-003202</p>	 <p style="text-align: center;">S810-103202</p>
4	 <p style="text-align: center;">S810-004202</p>	 <p style="text-align: center;">S810-104202</p>

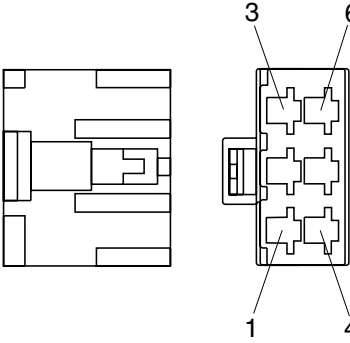
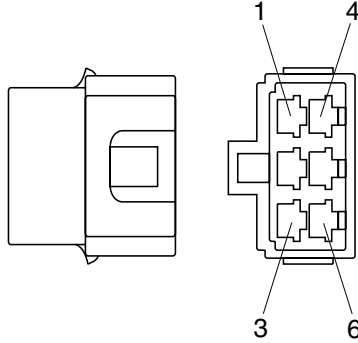
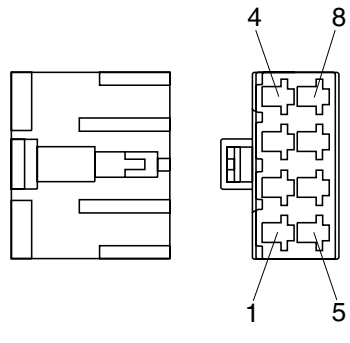
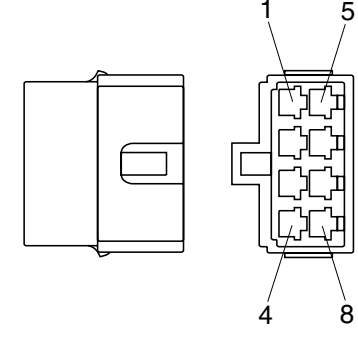
No. of pin	Receptacle connector (female)	Plug connector (male)
6	 <p data-bbox="686 638 837 672">S810-006202</p>	 <p data-bbox="1236 638 1388 672">S810-106202</p>
8	 <p data-bbox="686 1048 837 1081">S810-008202</p>	 <p data-bbox="1236 1048 1388 1081">S810-108202</p>

5) 375 FASTEN TYPE CONNECTOR

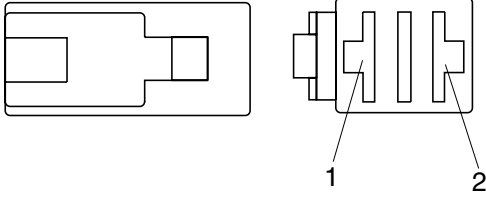
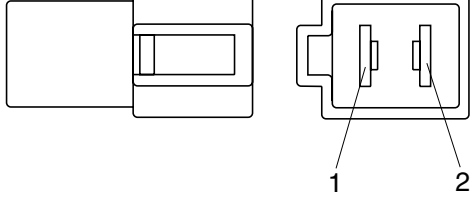
No. of pin	Receptacle connector (female)	Plug connector (male)
2	 <p style="text-align: center;">S810-002402</p>	 <p style="text-align: center;">S810-102402</p>

6) AMP ECONOSEAL CONNECTOR

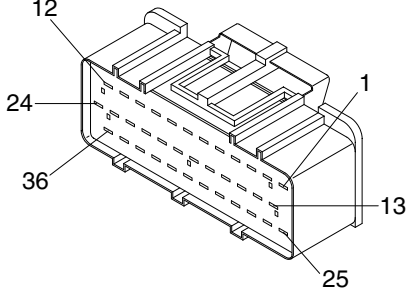
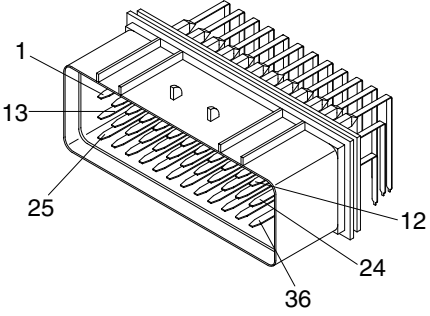
No. of pin	Receptacle connector (female)	Plug connector (male)
36	 <p style="text-align: center;">344111-1</p>	 <p style="text-align: center;">344108-1</p>

7) AMP TIMER CONNECTOR

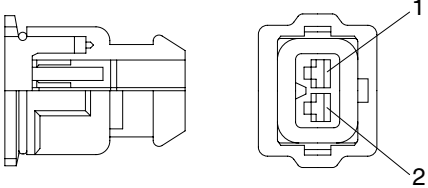
No. of pin	Receptacle connector (female)	Plug connector (male)
2	 <p style="text-align: center;">85202-1</p>	

8) AMP 040 MULTILOCK CONNECTOR

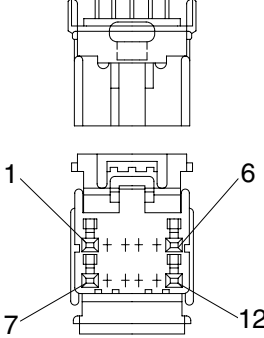
No. of pin	Receptacle connector (female)	Plug connector (male)
12	 <p style="text-align: right;">174045-2</p>	

9) AMP 070 MULTILOCK CONNECTOR

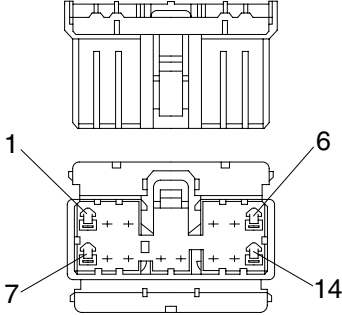
No. of pin	Receptacle connector (female)	Plug connector (male)
14	 <p style="text-align: right;">173852</p>	

10) AMP FASTIN - FASTON CONNECTOR

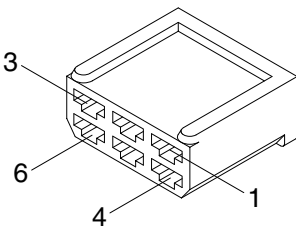
No. of pin	Receptacle connector (female)	Plug connector (male)
6	 <p style="text-align: right;">925276-0</p>	

11) KET 090 CONNECTOR

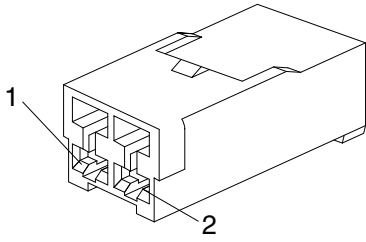
No. of pin	Receptacle connector (female)	Plug connector (male)
2	 <p style="text-align: right;">MG610070</p>	

12) KET 090 WP CONNECTORS

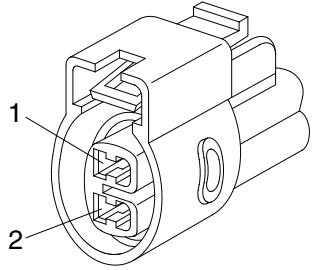
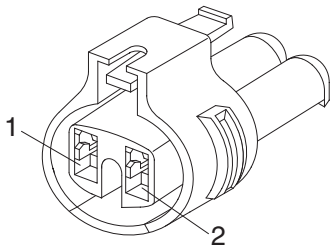
No. of pin	Receptacle connector (female)	Plug connector (male)
2	 <p style="text-align: right;">MG640605</p>	
2	 <p style="text-align: right;">MG640795</p>	

13) KET SDL CONNECTOR

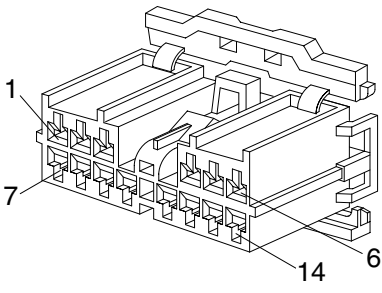
No. of pin	Receptacle connector (female)	Plug connector (male)
14	 <p data-bbox="710 683 837 705">MG610406</p>	

14) DEUTSCH DT CONNECTORS

DT 06 - 3S - ★★☆☆

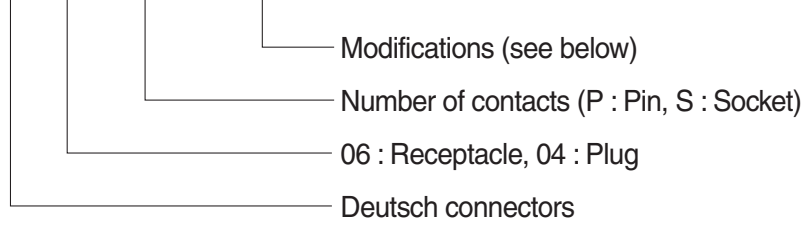

※ Modification

E003 : Standard end cap - gray

E004 : Color of connector to be black

E005 : Combination - E004 & E003

EP04 : End cap

EP06 : Combination P012 & EP04

P012 : Front seal enhancement - connectors color to black for 2, 3, 4 & 6pin

No. of pin	Receptacle connector (female)	Plug connector (male)
2	<p>DT06-2S</p>	<p>DT04-2P</p>
3	<p>DT06-3S</p>	<p>DT04-3P</p>
4	<p>DT06-4S</p>	<p>DT04-4P</p>

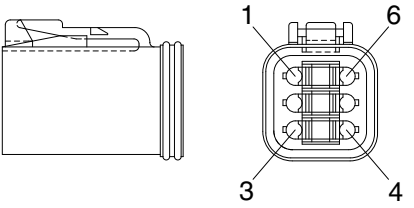
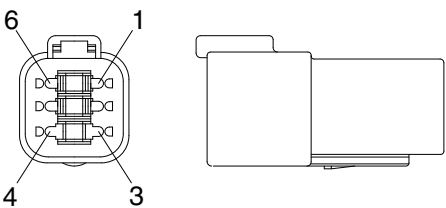
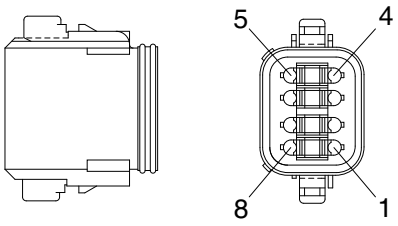
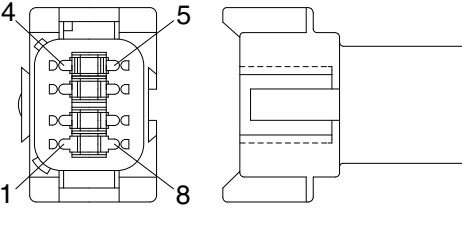
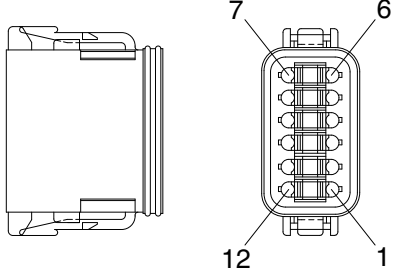
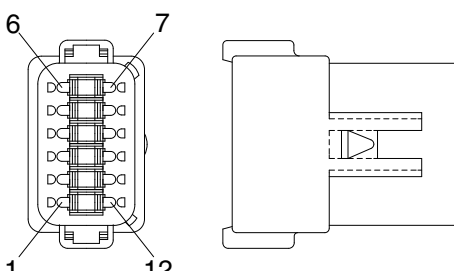
No. of pin	Receptacle connector (female)	Plug connector (male)
6	 <p style="text-align: center;">DT06-6S</p>	 <p style="text-align: center;">DT04-6P</p>
8	 <p style="text-align: center;">DT06-8S</p>	 <p style="text-align: center;">DT04-8P</p>
12	 <p style="text-align: center;">DT06-12S</p>	 <p style="text-align: center;">DT04-12P</p>

15) MOLEX 2CKTS CONNECTOR

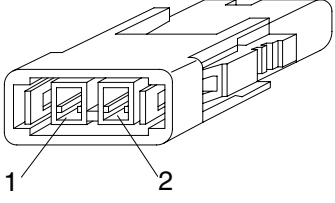
No. of pin	Receptacle connector (female)	Plug connector (male)
2	 <p data-bbox="702 683 837 712">35215-0200</p>	

16) ITT SWF CONNECTOR

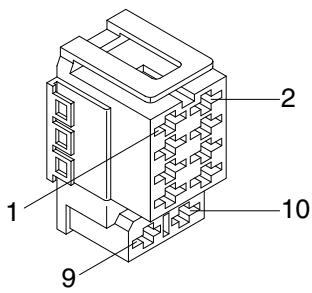
No. of pin	Receptacle connector (female)	Plug connector (male)
10	 <p data-bbox="694 1288 837 1317">SWF593757</p>	

17) MWP NMWP CONNECTOR

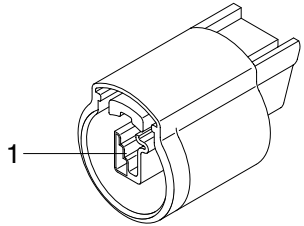
No. of pin	Receptacle connector (female)	Plug connector (male)
1	 <p data-bbox="686 1892 837 1921">NMWP01F-B</p>	

18) ECONOSEAL J TYPE CONNECTORS

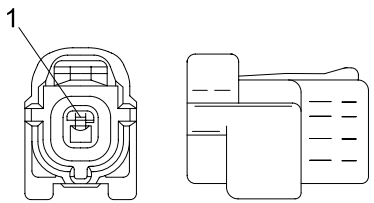
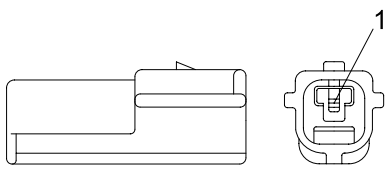
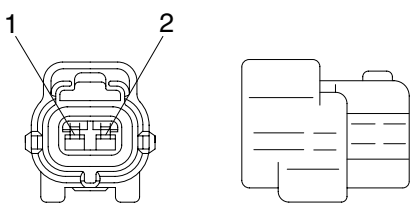
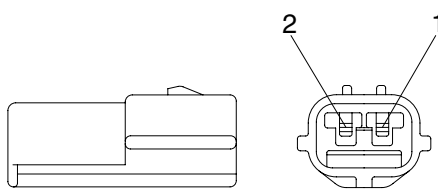
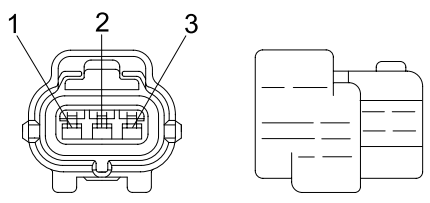
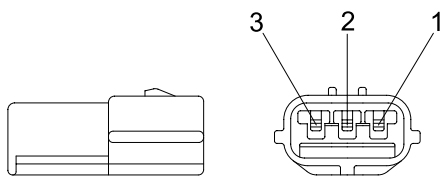
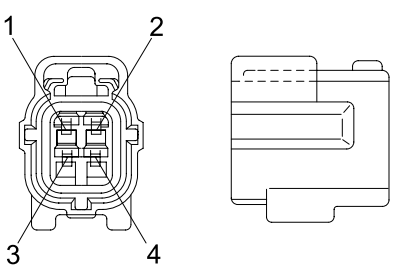
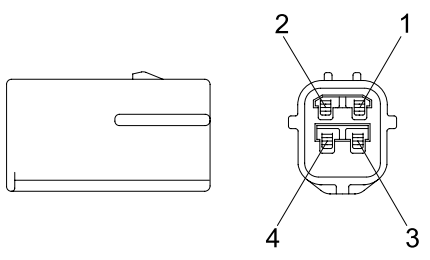
No. of pin	Receptacle connector (female)	Plug connector (male)
1	 <p style="text-align: right;">S816-001002</p>	 <p style="text-align: left;">S816-101002</p>
2	 <p style="text-align: right;">S816-002002</p>	 <p style="text-align: left;">S816-102002</p>
3	 <p style="text-align: right;">S816-003002</p>	 <p style="text-align: left;">S816-103002</p>
4	 <p style="text-align: right;">S816-004002</p>	 <p style="text-align: left;">S816-104002</p>

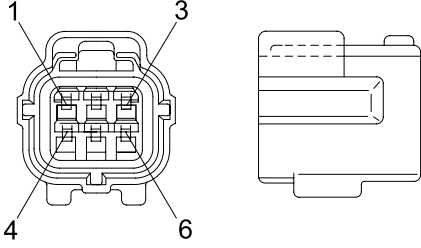
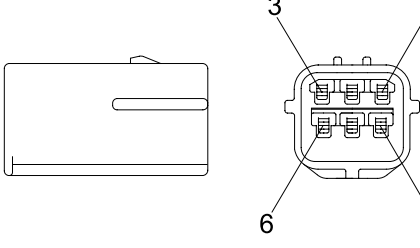
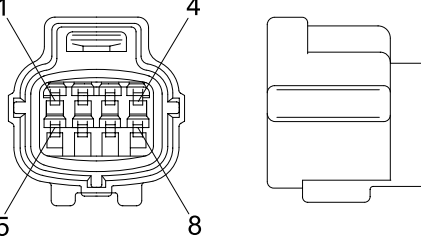
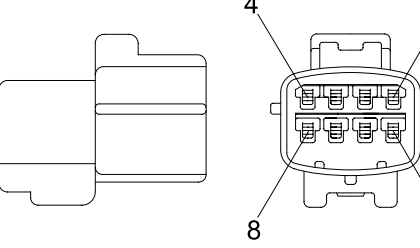
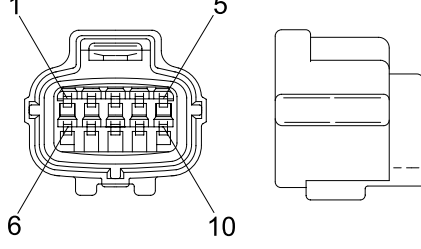
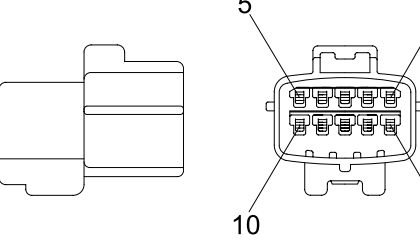
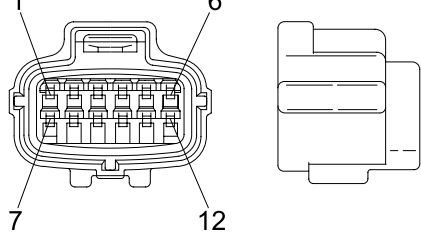
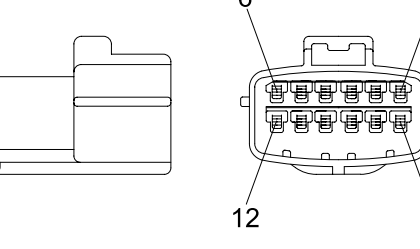
No. of pin	Receptacle connector (female)	Plug connector (male)
6	 <p style="text-align: center;">S816-006002</p>	 <p style="text-align: center;">S816-106002</p>
8	 <p style="text-align: center;">S816-008002</p>	 <p style="text-align: center;">S816-108002</p>
10	 <p style="text-align: center;">S816-010002</p>	 <p style="text-align: center;">S816-110002</p>
12	 <p style="text-align: center;">S816-012002</p>	 <p style="text-align: center;">S816-112002</p>

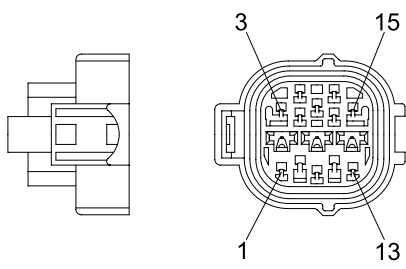
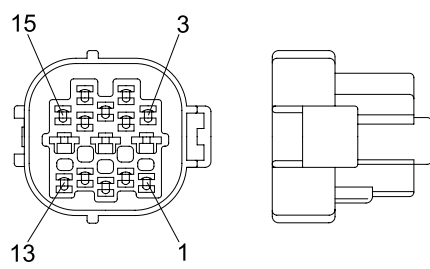
No. of pin	Receptacle connector (female)	Plug connector (male)
15	 <p data-bbox="730 638 837 672">368301-1</p>	 <p data-bbox="1276 638 1383 672">2-85262-1</p>

19) METRI-PACK TYPE CONNECTOR

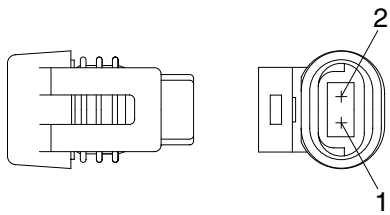
No. of pin	Receptacle connector (female)	Plug connector (male)
2	 <p data-bbox="726 1243 833 1276">12040753</p>	

20) DEUTSCH HD30 CONNECTOR

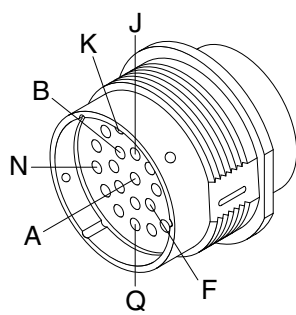
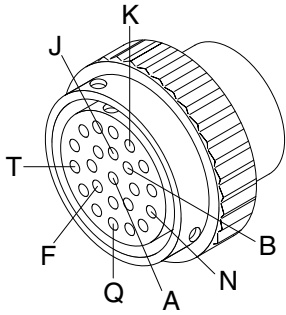
No. of pin	Receptacle connector (female)	Plug connector (male)
23	 <p data-bbox="662 1848 837 1881">HD36-24-23SN</p>	 <p data-bbox="1220 1848 1396 1881">HD34-24-23PN</p>

21) DEUTSCH MCU CONNECTOR

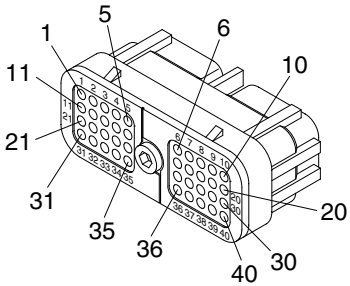
No. of pin	Receptacle connector (female)	Plug connector (male)
40	 <p style="text-align: right;">DRC26-40SA/B</p>	

22) DEUTSCH SERVICE TOOL CONNECTOR

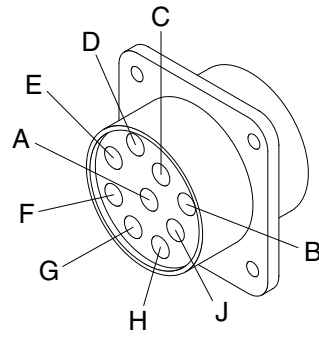
No. of pin	Receptacle connector (female)	Plug connector (male)
9	 <p style="text-align: right;">HD10-9-96P</p>	

23) AMP FUEL WARMER CONNECTOR

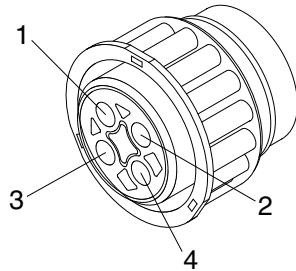
No. of pin	Receptacle connector (female)	Plug connector (male)
4	 <p style="text-align: right;">2-967325-3</p>	

24) DEUTSCH INTERMEDIATE CONNECTOR

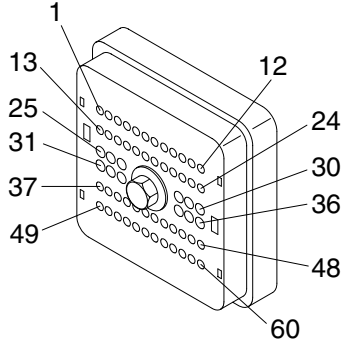
No. of pin	Receptacle connector (female)	Plug connector (male)
60	 <p style="text-align: center;">DRB16-60SAE-L018</p>	