

GROUP 3 TRACK AND WORK EQUIPMENT

1. TRACK

1) TRACK ROLLER

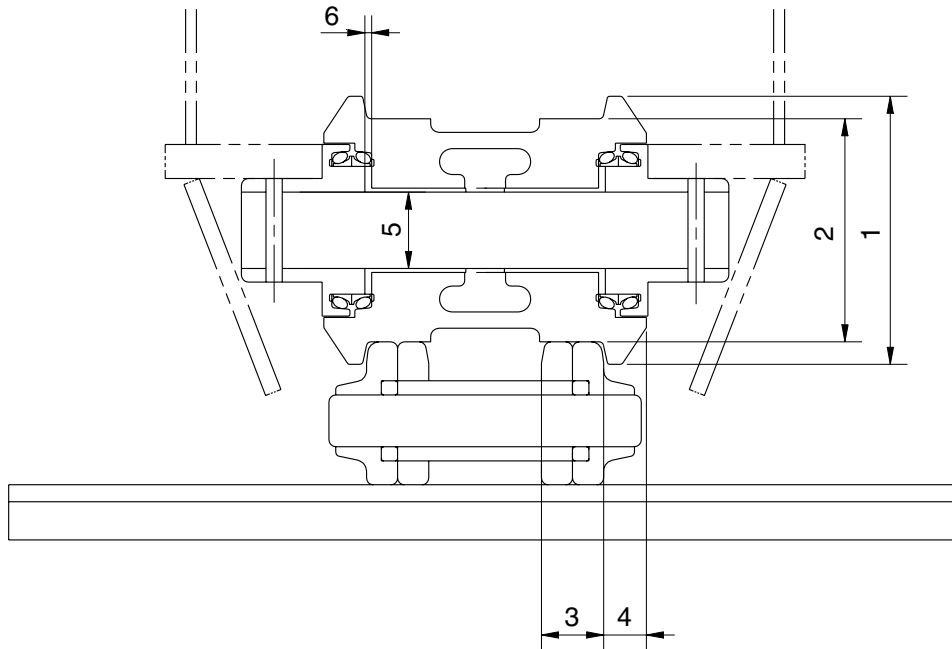

21037MS01

Unit : mm

No.	Check item	Criteria				Remedy
		Standard size		Repair limit		
1	Outside diameter of flange	ø 200		-		Rebuild or replace
2	Outside diameter of tread	ø 160		ø 148		
3	Width of tread	48		54		
4	Width of flange	21.5		-		
5	Clearance between shaft and bushing	Standard size & tolerance		Standard clearance	Clearance limit	Replace bushing
		Shaft	Hole			
		ø 70 $\begin{matrix} -0.29 \\ -0.33 \end{matrix}$	ø 70.1 $\begin{matrix} +0.46 \\ 0 \end{matrix}$			
6	Side clearance of roller (both side)	Standard clearance		Clearance limit		Replace
		0.2 to 1.2		2.0		

2) CARRIER ROLLER

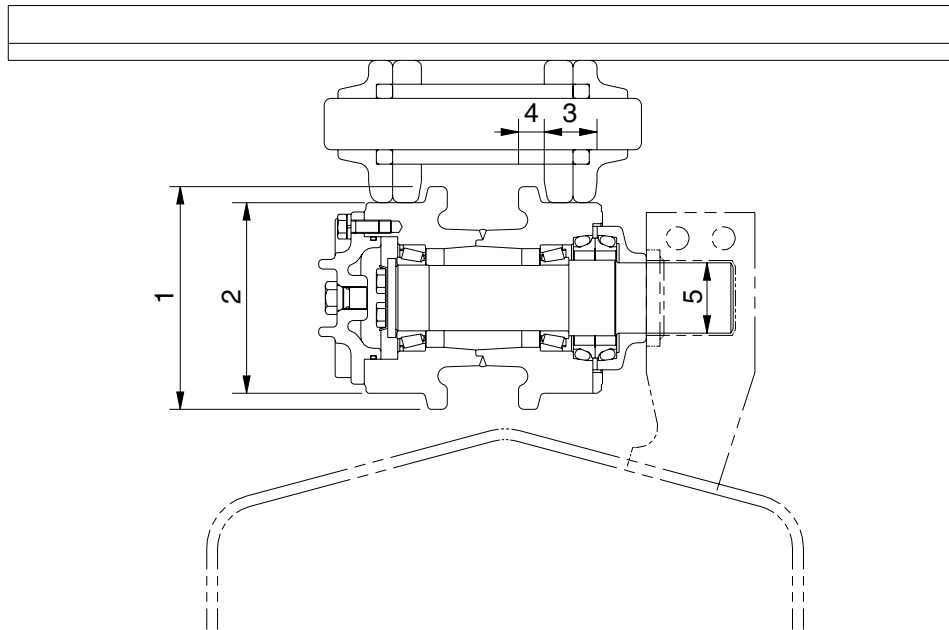

21037MS02

Unit : mm

No.	Check item	Criteria				Remedy	
		Standard size		Repair limit			
1	Outside diameter of flange	ø 169		-		Rebuild or replace	
2	Outside diameter of tread	ø 144		ø 134			
3	Width of tread	44		49			
4	Width of flange	17		-			
5	Clearance between shaft and bushing	Standard size	Tolerance		Standard clearance 0.15 to 0.4	Clearance limit 1.2	Replace bushing
		ø 55	Shaft	Hole			
			-0.05 -0.1	+0.3 +0.1			

3) IDLER

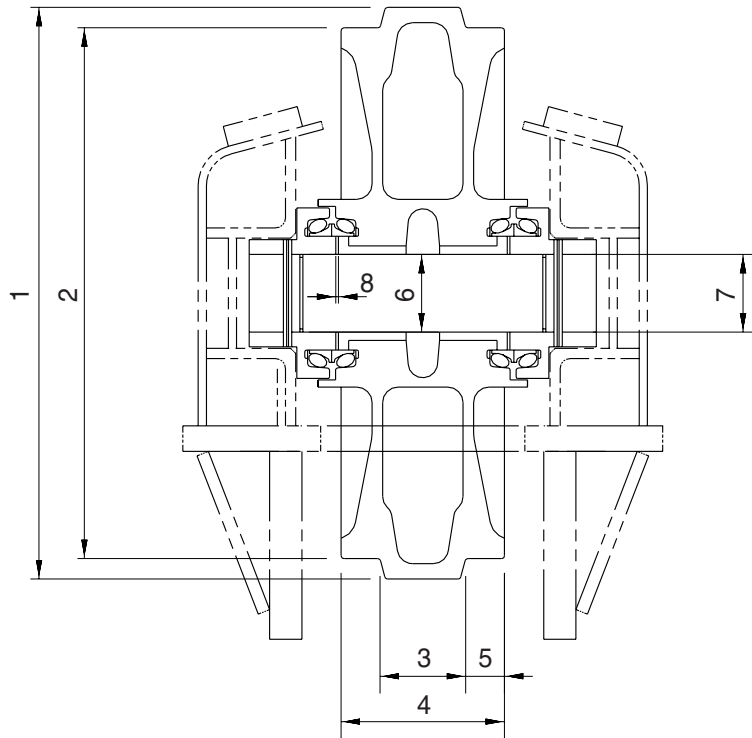

21037MS03

Unit : mm

No.	Check item	Criteria		Remedy		
		Standard size	Repair limit			
1	Outside diameter of protrusion	$\phi 560$	-	Rebuild or replace		
2	Outside diameter of tread	$\phi 520$	$\phi 510$			
3	Width of protrusion	84	-			
4	Total width	160	-			
5	Width of tread	38	43			
6	Clearance between shaft and bushing	Standard size & tolerance		Standard clearance	Clearance limit	Replace bushing
		Shaft	Hole			
		$\phi 75 \begin{matrix} 0 \\ -0.03 \end{matrix}$	$\phi 75.35 \begin{matrix} +0.05 \\ 0 \end{matrix}$	0.35 to 0.43	2.0	
7	Clearance between shaft and support	$\phi 75 \begin{matrix} 0 \\ -0.03 \end{matrix}$	$\phi 75 \begin{matrix} +0.07 \\ +0.03 \end{matrix}$	0.03 to 0.1	1.2	Replace
8	Side clearance of idler (both side)	Standard clearance		Clearance limit		Replace bushing
		0.25 to 1.2		2.0		

4) TRACK

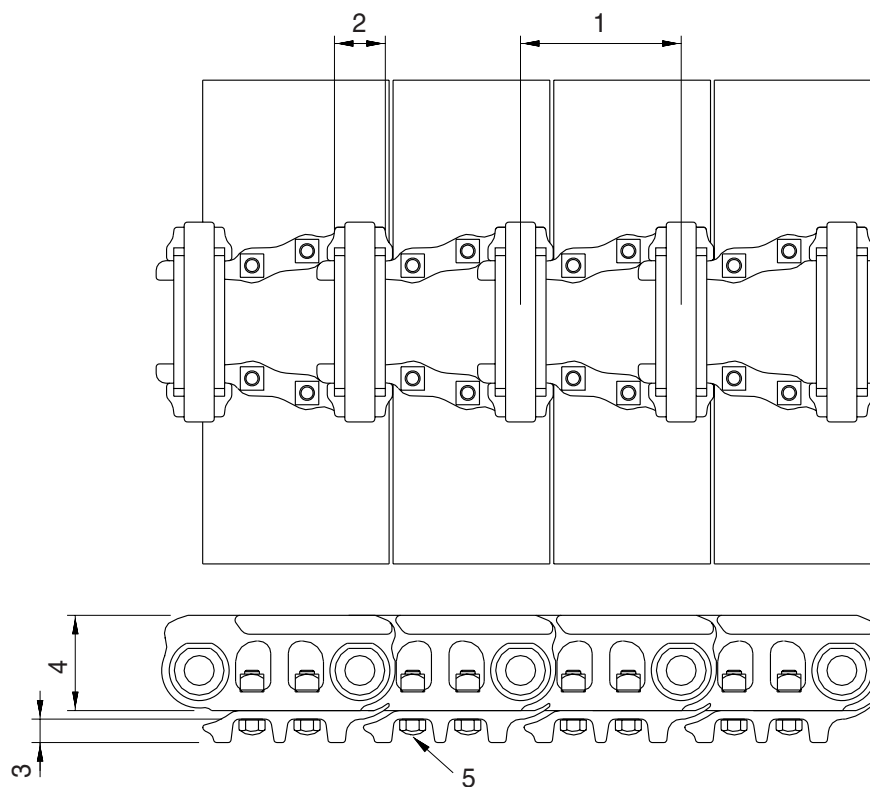

21037MS04

Unit : mm

No.	Check item	Criteria		Remedy
		Standard size	Repair limit	
1	Link pitch	190	194.4	Turn or replace
2	Outside diameter of bushing	∅ 59	∅ 51	
3	Height of grouser	26	16	Rebuild or replace
4	Height of link	105	97	
5	Tightening torque	Initial tightening torque : 78 ± 8 kgf · m		Retighten

5) TRACK FRAME AND RECOIL SPRING

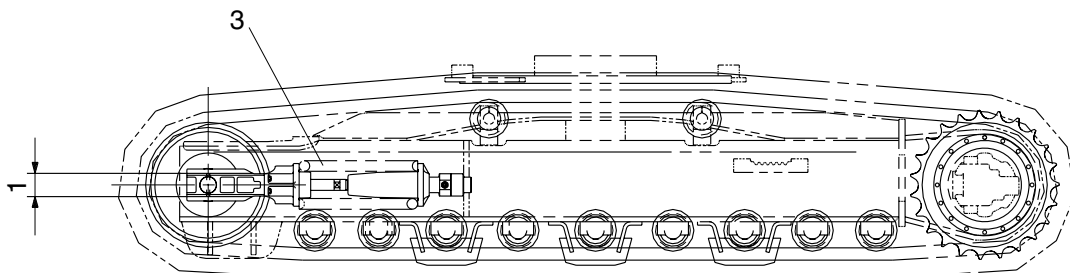
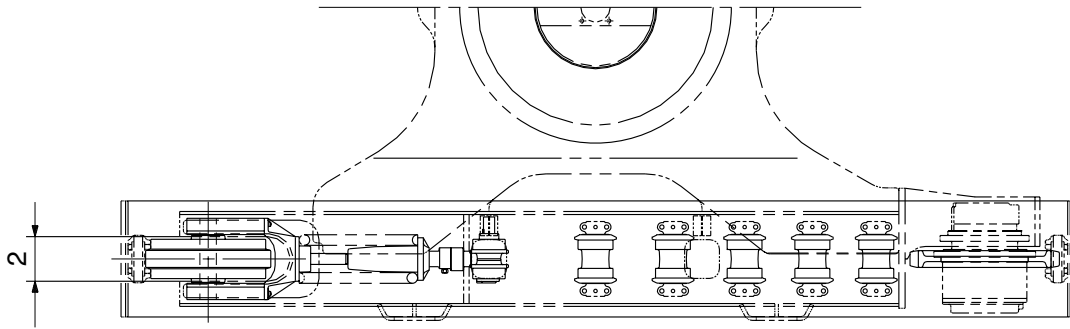

21037MS05

Unit : mm

No.	Check item	Criteria				Remedy	
			Standard size	Tolerance	Repair limit		
1	Vertical width of idler guide	Track frame	113	+2 0	117	Rebuild or replace	
		Idler support	110	-0.5 -1.0	106		
2	Horizontal width of idler guide	Track frame	272	+2 0	276		
		Idler support	270	-	267		
3	Recoil spring	Standard size			Repair limit		Replace
		Free length	Installation length	Installation load	Free length	Installation load	
		∅ 235 × 515	431	13716kg	-	10973kg	

2. WORK EQUIPMENT

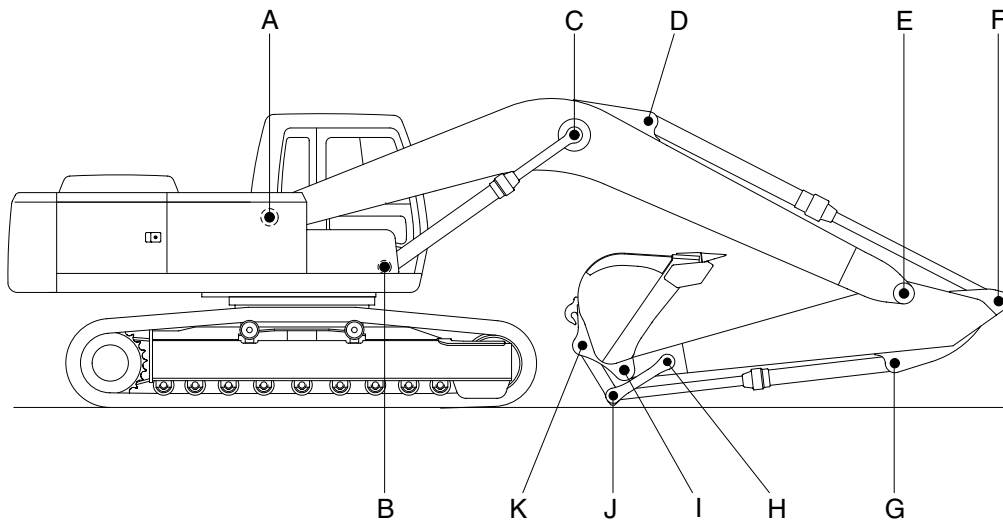

21077MS20

Unit : mm

Mark	Measuring point (Pin and Bushing)	Normal value	Pin		Bushing		Remedy & Remark
			Recomm. service limit	Limit of use	Recomm. service limit	Limit of use	
A	Boom Rear	90	89	88.5	90.5	91	Replace
B	Boom Cylinder Head	80	79	78.5	80.5	81	"
C	Boom Cylinder Rod	80	79	78.5	80.5	81	"
D	Arm Cylinder Head	80	79	78.5	80.5	81	"
E	Boom Front	90	89	88.5	90.5	91	"
F	Arm Cylinder Rod	80	79	78.5	80.5	81	"
G	Bucket Cylinder Head	80	79	78.5	80.5	81	"
H	Arm Link	70	69	68.5	70.5	71	"
I	Bucket and Arm Link	80	79	78.5	80.5	81	"
J	Bucket Cylinder Rod	80	79	78.5	80.5	81	"
K	Bucket Link	80	79	78.5	80.5	81	"