

GROUP 5 SWING DEVICE (TYPE 1)

1. REMOVAL AND INSTALL OF MOTOR

1) REMOVAL

- (1) Lower the work equipment to the ground and stop the engine.
- (2) Operate the control levers and pedals several times to release the remaining pressure in the hydraulic piping.
- (3) Loosen the breather slowly to release the pressure inside the hydraulic tank.

▲ Escaping fluid under pressure can penetrate the skin causing serious injury.

※ When pipes and hoses are disconnected, the oil inside the piping will flow out, so catch it in oil pan.

- (4) Disconnect hose assembly (2).
- (5) Disconnect pilot line hoses (3, 4, 5, 6, 7, 8).
- (6) Sling the swing motor assembly (1) and remove the swing motor mounting socket bolts (9).

· Motor device weight : 61 kg (135 lb)

- (7) Remove the swing motor assembly.
※ When removing the swing motor assembly, check that all the piping have been disconnected.



13031GE18

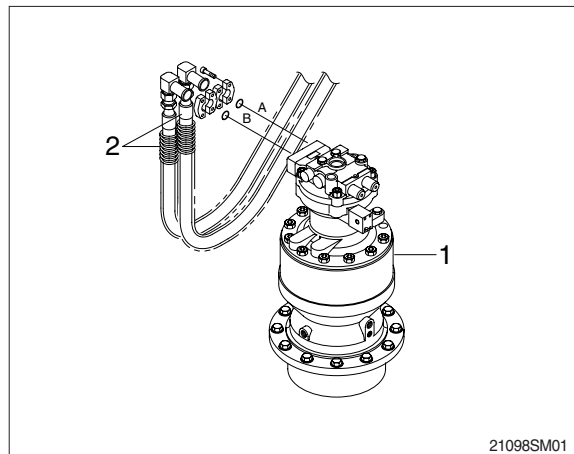

21098SM01

2) INSTALL

- (1) Carry out installation in the reverse order to removal.
- (2) Bleed the air from the swing motor.
 - ① Remove the air vent plug.
 - ② Pour in hydraulic oil until it overflows from the port.
 - ③ Tighten plug lightly.
 - ④ Start the engine, run at low idling and check oil come out from plug.
 - ⑤ Tighten plug fully.
- (3) Confirm the hydraulic oil level and check the hydraulic oil leak or not.

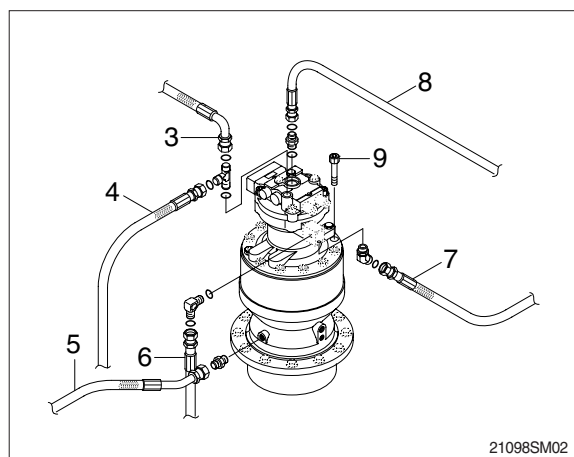

21098SM02

2. DISASSEMBLY AND ASSEMBLY OF SWING MOTOR

1) STRUCTURE

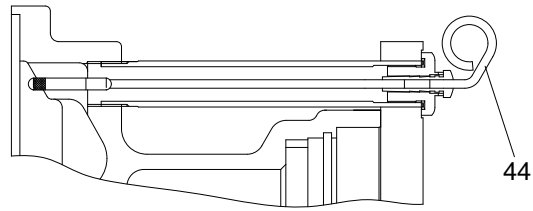

DETAIL K

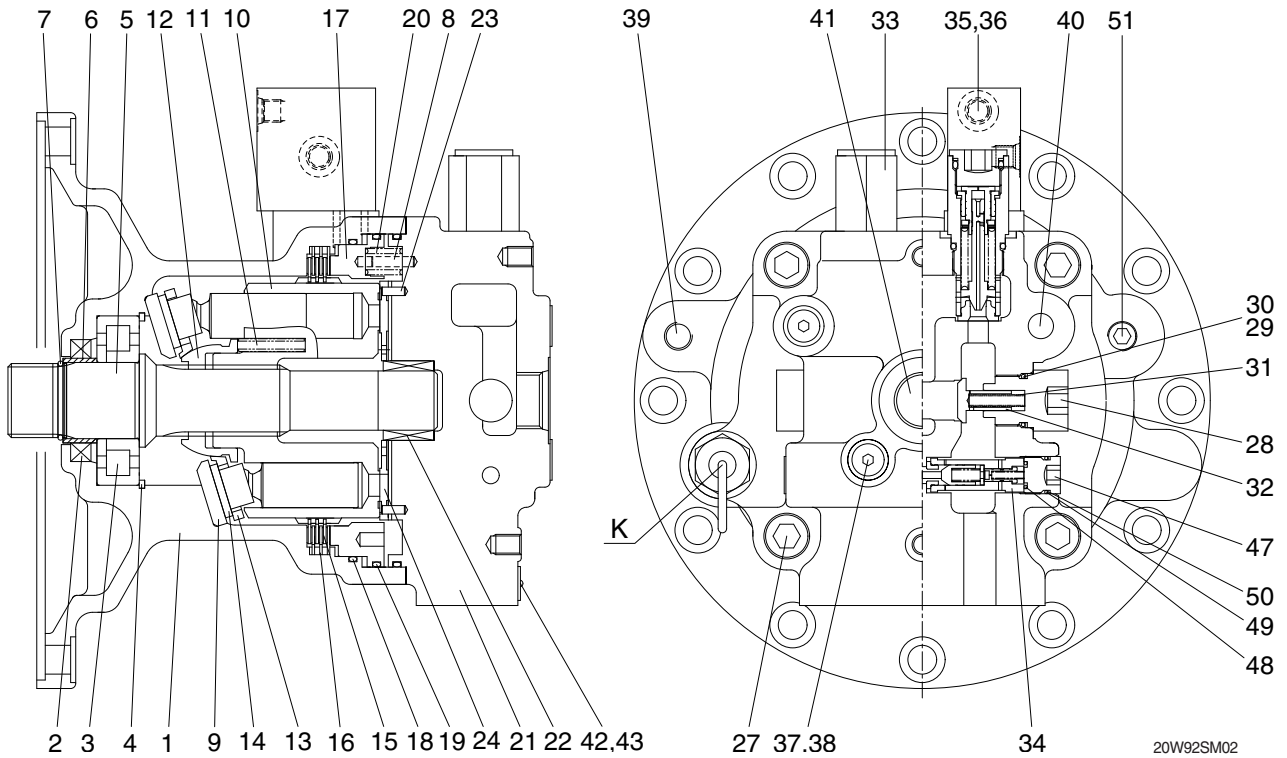

20W92SM02

- | | | | | | |
|----|----------------|----|----------------------|----|------------------|
| 1 | Body | 17 | Brake piston | 35 | Time delay valve |
| 2 | Oil seal | 18 | O-ring | 36 | Wrench bolt |
| 3 | Roller bearing | 19 | O-ring | 37 | Plug |
| 4 | Snap ring | 20 | Brake spring | 38 | O-ring |
| 5 | Shaft | 21 | Rear cover | 39 | Plug |
| 6 | Bushing | 22 | Needle bearing | 40 | Plug |
| 7 | Stop ring | 23 | Pin | 41 | Plug |
| 8 | Pin | 24 | Valve plate | 42 | Name plate |
| 9 | Shoe plate | 27 | Wrench bolt | 43 | Rivet |
| 10 | Cylinder block | 28 | Plug | 44 | Level gauge |
| 11 | Spring | 29 | Back up ring | 47 | Plug |
| 12 | Ball guide | 30 | O-ring | 48 | O-ring |
| 13 | Set plate | 31 | Spring | 49 | O-ring |
| 14 | Piston assy | 32 | Check | 50 | Back up ring |
| 15 | Friction plate | 33 | Relief valve | | |
| 16 | Separate plate | 34 | Anti-inversion valve | | |

2) DISASSEMBLING

(1) Disassemble the sub of a TURNING AXIS

- ① Unloosing wrench bolt and disassemble time delay valve assy (35) from rear cover (21)

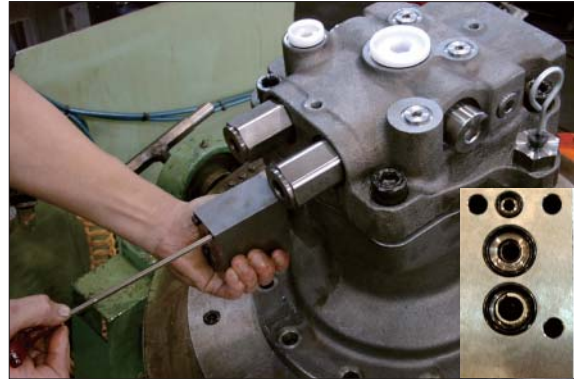

14078SM201/201A

- ② Disassemble level gauge (44) from body (1).



14078SM202/202A

- ③ Hang rear cover (21) on hoist, unloose wrench bolt (27) and disassemble from body (1).



14078SM203/203A

- ④ Using a jig, disassemble break piston (17) from body (1).

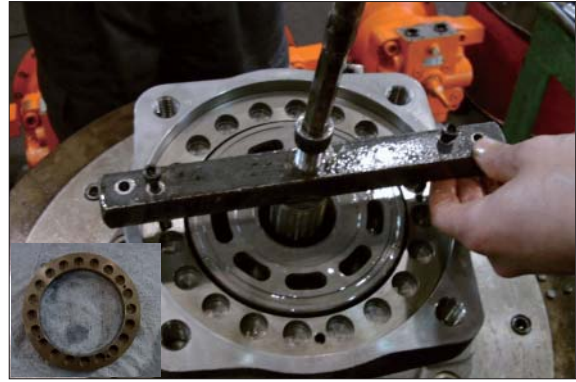

14078SM204/204A

- ⑤ Disassemble respectively cylinder block assy, friction plate (15), plate (16) from body (1).

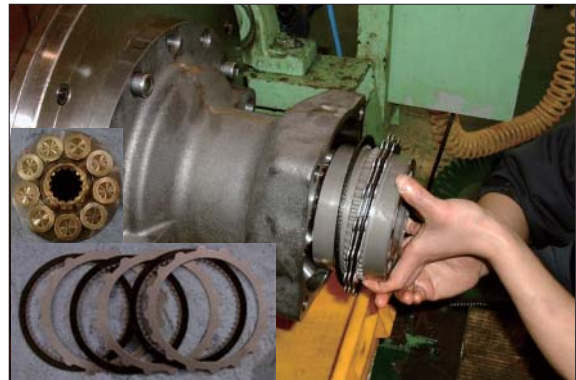

14078SM205/205A/B

(2) Disassemble cylinder block assy sub

- ① Disassemble piston assy (14), set plate (13) from cylinder block assy.



14078SM206/205B

- ② Disassemble ball guide (12) from cylinder block (10).



14078SM207/207A

- ③ Disassemble spring (11) from cylinder block (10).

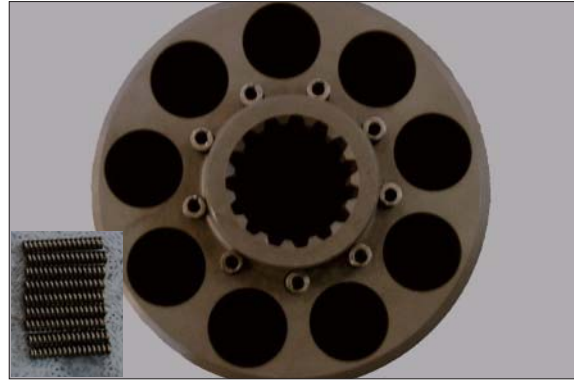

14078SM208/208A

- ④ Disassemble shoe plate (9) from body (1).



14078SM209/209A

- ⑤ Using a plier jig, disassemble snap ring (4) from shaft (5).



14078SM210/210A

- ⑥ Disassemble shaft assy from body (1).

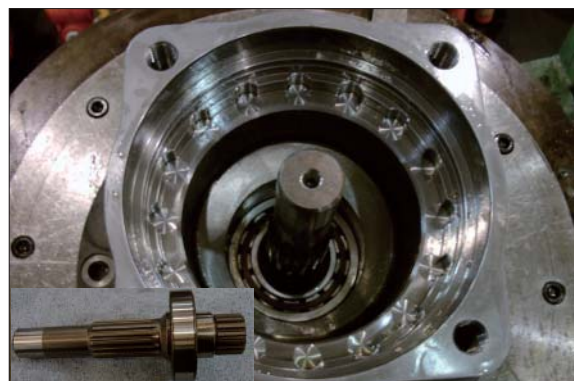

14078SM211/211A

(3) Disassemble rear cover assy sub

- ① Disassemble pin (8, 23), valve plate (24) from rear cover (21).

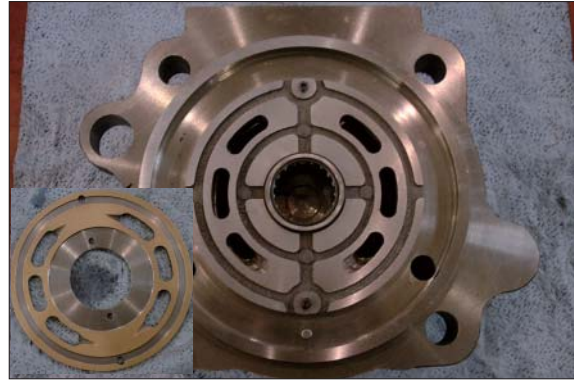

14078SM212/212A

- ② Using a torque wrench, disassemble relief valve assy (33) 2 set from rear cover (21).



14078SM213/213A

- ③ After disassembling plug with a L-wrench from rear cover (21), disassemble respectively back up ring, O-ring, O-ring, spring, anti-inversion valve assy (34)

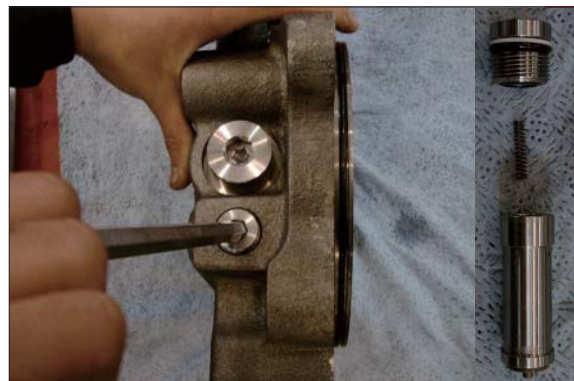

14078SM214/214A

- ④ Disassemble make up check valve assy with a torque wrench from rear cover (21).

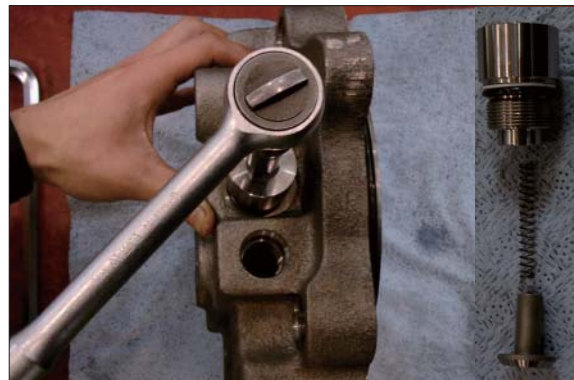

14078SM215/215A

- ⑤ Disassemble respectively plug (37, 40, 41), with a L-wrench from rear cover (21).

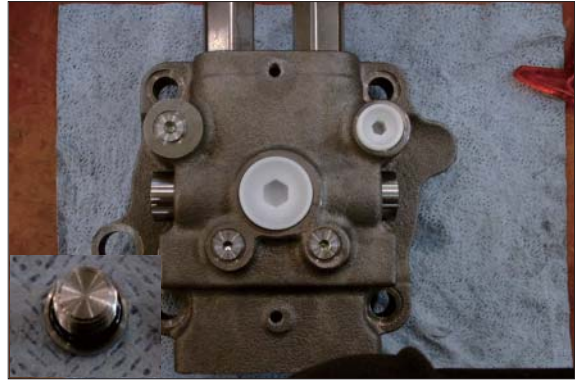

14078SM216/216A

3) ASSEMBLING

(1) Assemble the sub of a turning axls

- ① Put roller bearing (3), bushing (6) on pre-heater and provide heat to inner wheel (compressing temp : 290°C for 2minutes)
 - Roller bearing × 1 EA
 - Bushing × 1 EA

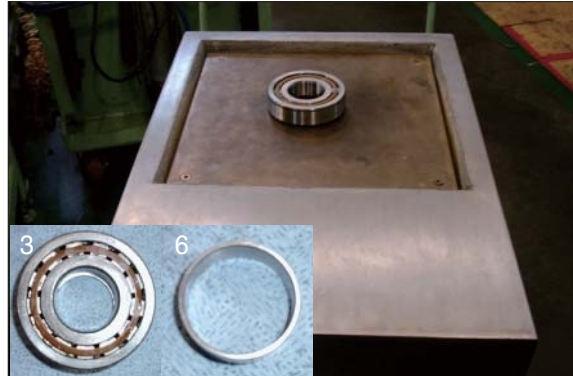

14078SM217/217A/B

- ② After assembling and compressing pre-heated roller bearing (3), bushing (6) into shaft (5).
 - Stop ring × 1 EA
 - Shaft × 1 EA



14078SM218/218A/B

- ③ Put body (1) on a assembling jig, fix it with bolts to prohibit moving.

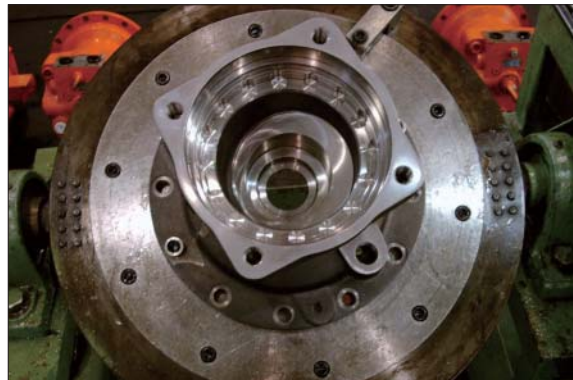

14078SM219

- ④ Using a compressing tool and steel stick, assemble oil seal (2) into body (1).
· Oil seal × 1 EA

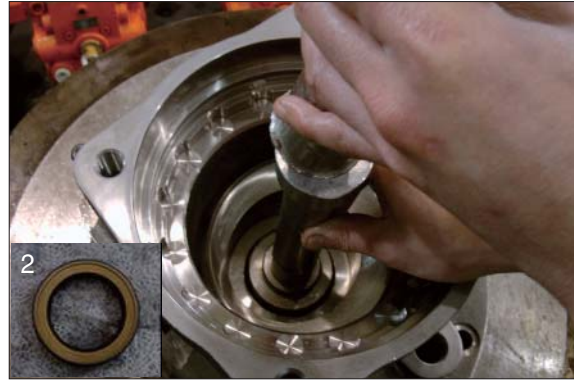

14078SM220/220A

- ⑤ Insert above shaft sub into body (1) and assemble it with a steel stick.

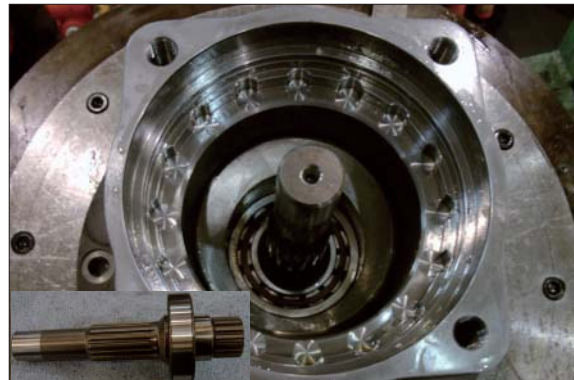

14078SM211/211A

- ⑥ Fix snap ring (4) to shaft with a plier jig.

· Snap ring × 1 EA



14078SM210/210A

- ⑦ Spread grease on shoe plate (9) and assemble on the body.

· Shoe plate × 1 EA

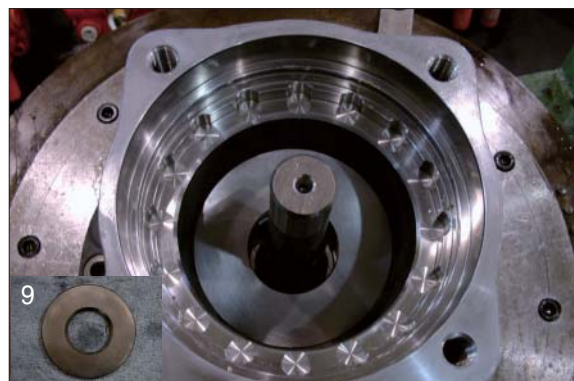

14078SM222/209A

(2) Assemble the sub of cylinder block assy

- ① Assemble spring (11) 9 set into cylinder block (10).
· Spring × 9 EA

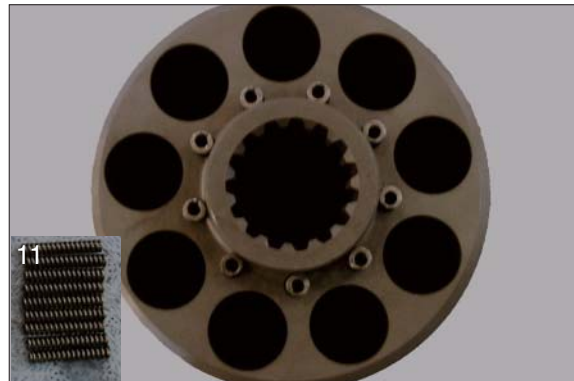

14078SM208/208A

- ② Assemble ball guide (12) into cylinder.
· Ball guide × 1 EA



14078SM207/207A

- ③ Assemble piston assy (14) 9 set into set plate (13).
- Piston assy × 9 EA
 - Set plate × 1 EA



14078SM223/223A

- ④ Assemble above item ② and ③.



14078SM224

- ⑤ Assemble cylinder block assy into body (1).

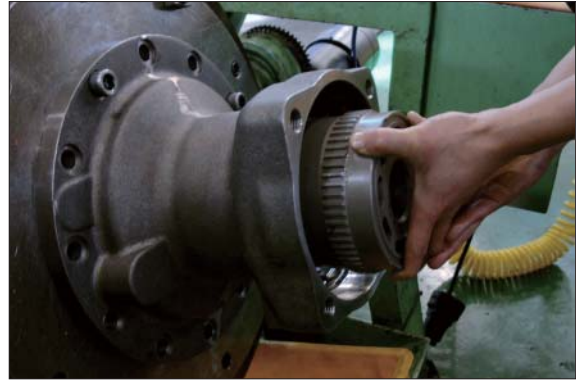

14078SM225

- ⑥ Assemble O-ring (18) into body (1).
· O-ring × 1 EA



14078SM226/226A

- ⑦ Assemble 3 set of plate (16), friction plate (15) respectively into body.
· Plate × 3 EA
· Friction plate × 3 EA

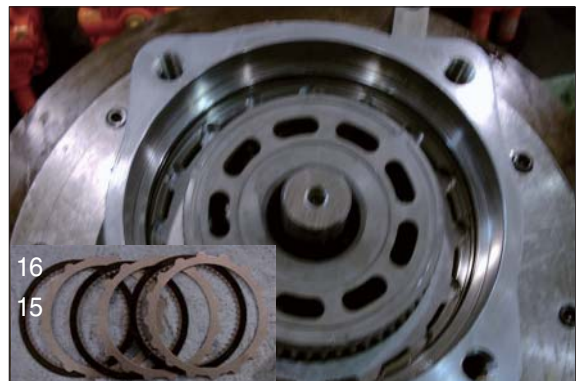

14078SM227/205A

- ⑧ Assemble O-ring (19) into break piston (17).
· O-ring × 2 EA



14078SM228/226A

- ⑨ Insert break piston assy into body (1) and compress it with a jig and hammer.

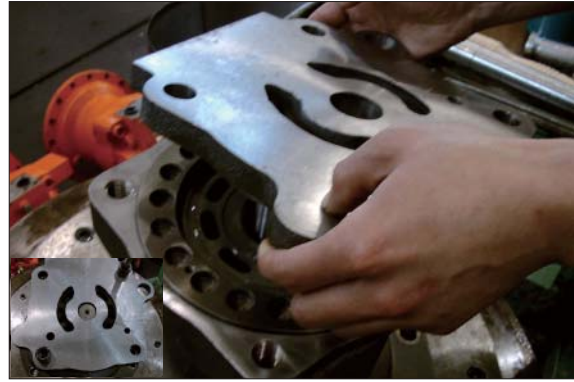

14078SM229/229A

- ⑩ Assemble spring (20) (20 EA) into break piston (17).
 · Spring × 20 EA

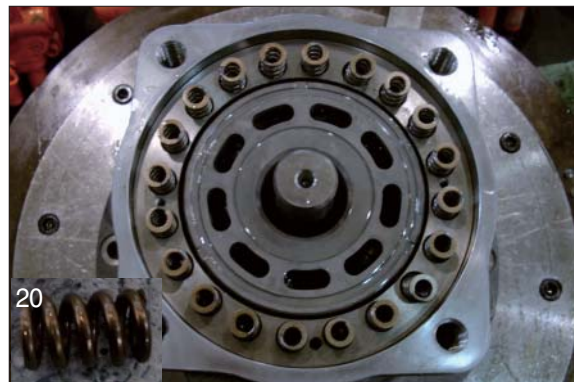

14078SM230/230A

(3) Assemble the sub of rear cover assy sub

- ① Assemble the sub of make up check valve assy.
 Assemble O-ring (30), back up ring (29) into plug (28) with a O-ring assembling jig.
 · Plug × 1 EA
 · Back up ring × 1 EA
 · O-ring × 1 EA



14078SM231/231A/B

- ② Assemble respectively make up check valve assy spring (31), check (32), plug (28) into rear cover (21) after then screw it torque wrench.
 · Make up check sub × 2 set
 · Spring × 2 EA
 · Check × 3 EA

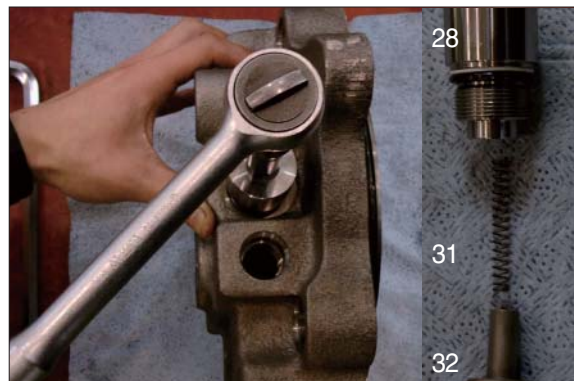

14078SM215/215A

- ③ Assemble respectively plug (47), back up ring, O-ring, O-ring, spring, anti-rotating valve assy (34) into rear cover (21).
(Bilateral symmetry assembling)
- Anti-Inversion v/v assy × 2 set
 - O-ring (P12) × 2 EA
 - O-ring (P18) × 2 EA
 - Back up ring (P18) × 2 EA

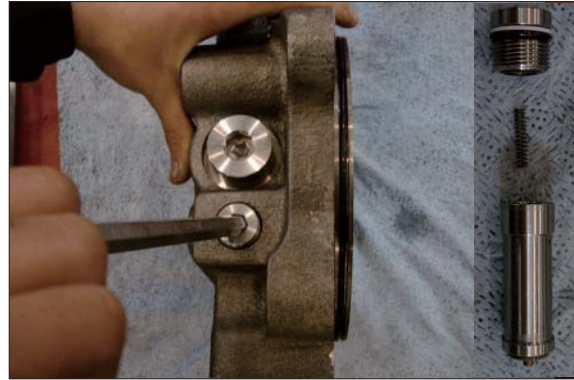

14078SM214/214A

- ④ Assemble relief valve assy (33) 2set into rear cover (21) with a torque wrench.
(Bilateral symmetry assembling)

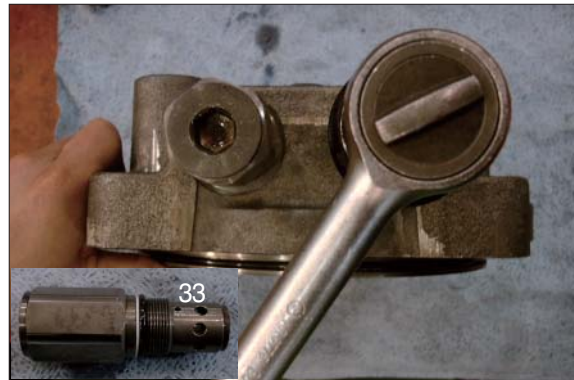

14078SM213/213A

- ⑤ Assemble plug (37), plug (40, 41) into rear cover (21) with a L-wrench.
* Plug × 3 EA (PF1/4)



14078SM216/216A

- ⑥ After assembling needle bearing (22) into rear cover (21), with a hammer assemble pin (8, 23).
* Pin × 1 EA
* Pin × 2 EA



14078SM212

- ⑦ Spreading grease on valve plate (24),
assemble into rear cover (21).
· Valve plate × 1 EA

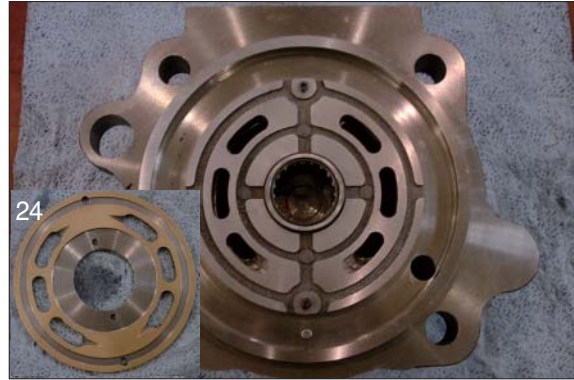

14078SM212/212A

- ⑧ Lift up rear cover assy on body (1) by a crane and assemble it with a wrench bolt (27).



14078SM203/203A

- ⑨ Assemble level gauge (44) into body (1).

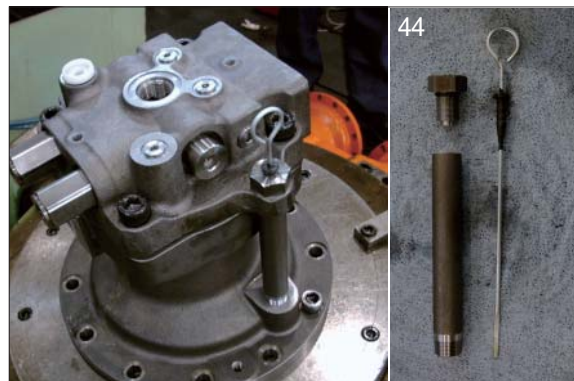

14078SM202/202A

- ⑩ Assemble time delay valve assy (35) into rear cover (21) with a wrench bolt (36).

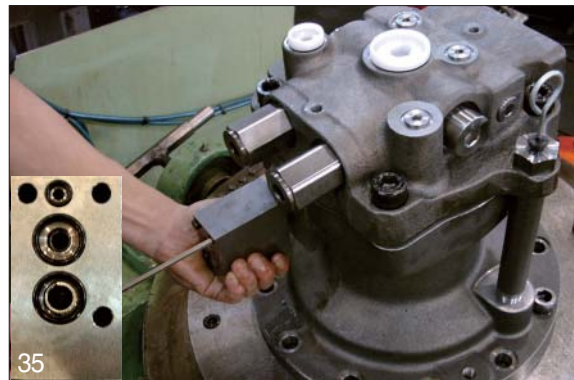

14078SM01/201A

(4) Air pressing test

Be sure of leakage, after press air into assembled motor

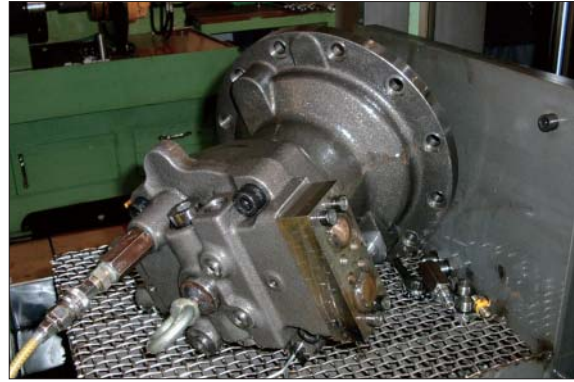

14078SM232

(5) Leakage check

After cleaning motor by color check No.1, paint No.3 and be sure of leakage.



14078SM233/233A

(6) Mount test bench

Mounting motor test bench, test the availability of each part.



220078SM14

3. REMOVAL AND INSTALL OF REDUCTION GEAR

1) REMOVAL

- (1) Remove the swing motor assembly.
For details, see removal of swing motor assembly.
- (2) Sling reduction gear assembly (1) and remove mounting bolts (2).
- (3) Remove the reduction gear assembly.
 - Reduction gear device weight : 180 kg
(396 lb)



2) INSTALL

- (1) Carry out installation in the reverse order to removal.
 - Tightening torque : 58.4 ± 6.4 kgf · m
(422 ± 46.3 lbf · ft)

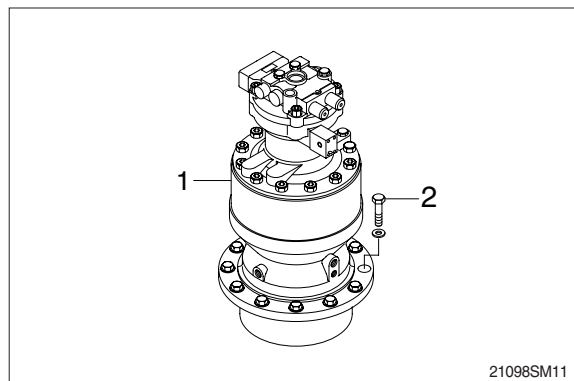

4. DISASSEMBLY AND ASSEMBLY OF REDUCTION GEAR

1) STRUCTURE

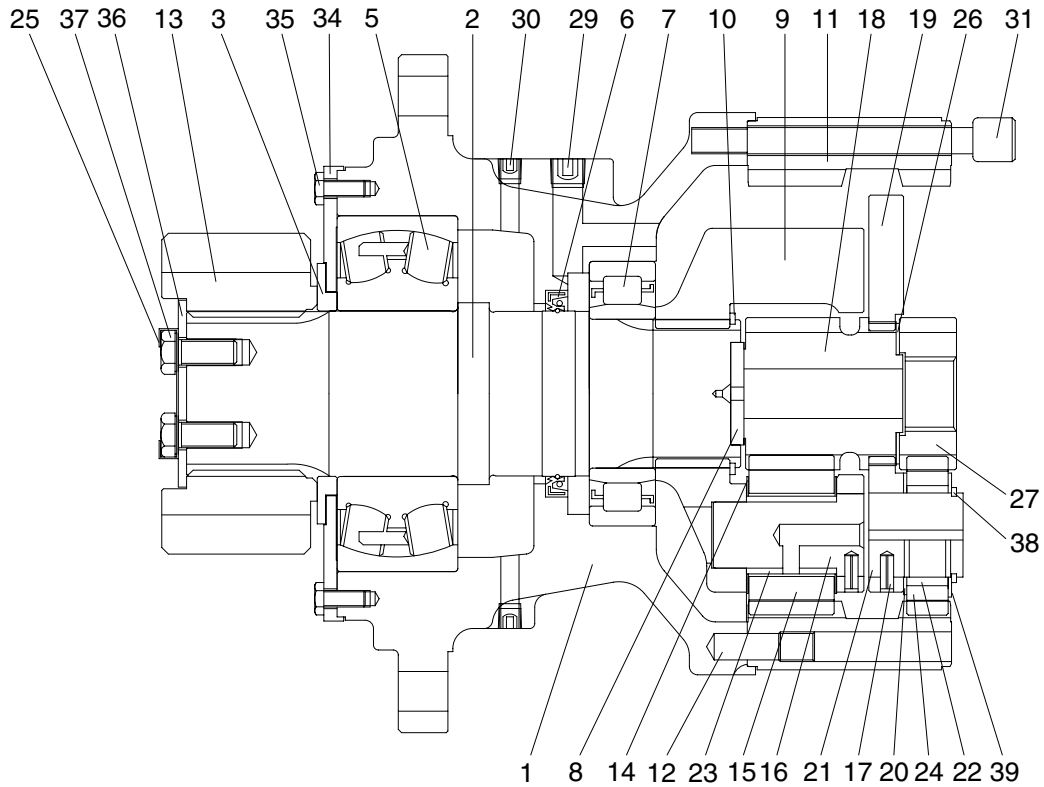

21092SM03

1	Casing	14	Thrust washer	26	Side plate 3
2	Drive shaft	15	Planet gear 2	27	Sun gear 1
3	Spacer	16	Pin & bushing	29	Plug
5	Roller bearing	17	Spring pin	30	Plug
6	Oil seal	18	Sun gear 2	31	Socket bolt
7	Roller bearing	19	Carrier 1	34	Cover plate
8	Thrust plate 3	20	Side plate 1	35	Hexagon bolt
9	Carrier 2	21	Pin 1	36	Lock plate
10	Stop ring	22	Needle cage	37	Hexagon bolt
11	Ring gear	23	Bushing 2	38	Stop ring
12	Knock pin	24	Planet gear 1	39	Side plate 2
13	Pinion gear	25	Lock washer		

2) DISASSEMBLY

- (1) Spread off the 4 corners of lock washer (25) with a tool.
 - ※ Do not reuse lock washer (25).
- Loosen the bolts (37) and then remove lock washer (25) and lock plate (36) from the pinion gear (13).
- Remove pinion gear (13) and spacer (3) from the drive shaft (2).
- Remove cover plate (34) from the casing (1) by loosening the hexagon bolts (35).

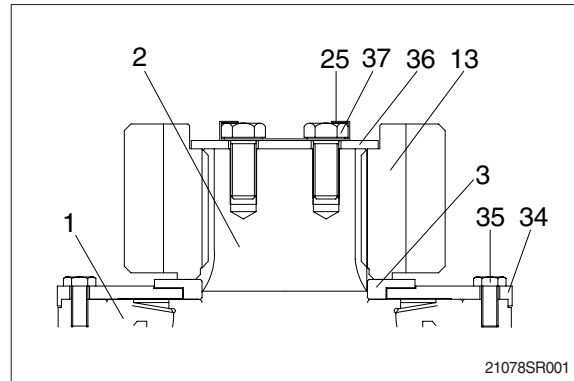

- (2) Remove gauge bar and gauge pipe from the swing motor casing.
 - ※ Pour the gear oil out of reduction gear into the clean bowl to check out the friction decrease.

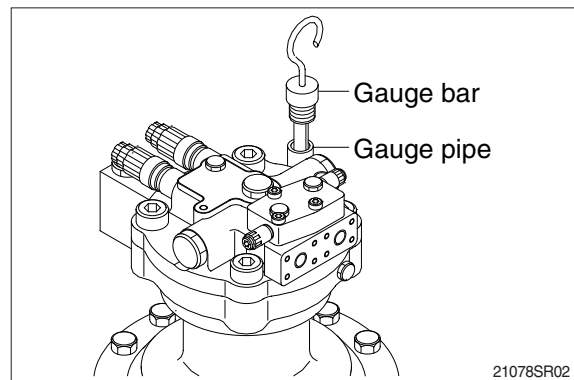

- (3) Loosen the socket bolts (31) to separate swing motor from reduction gear.

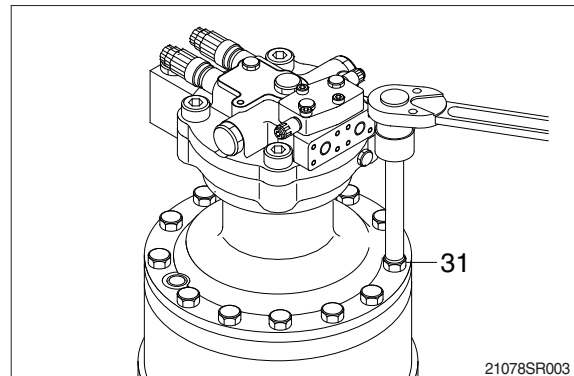

- (4) Tighten 3 M16 eye bolts to the ring gear (11) and then lift the ring gear (11) out of the casing (1).

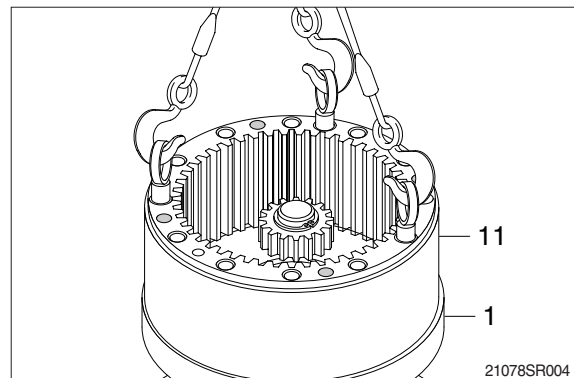

(5) Remove sun gear1 (27).

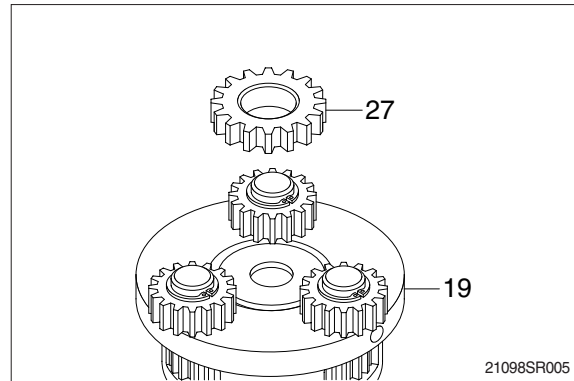

(6) Tighten two M10 eye bolts to carrier1 (19) and lift up and remove carrier1 (19) as subassembly.

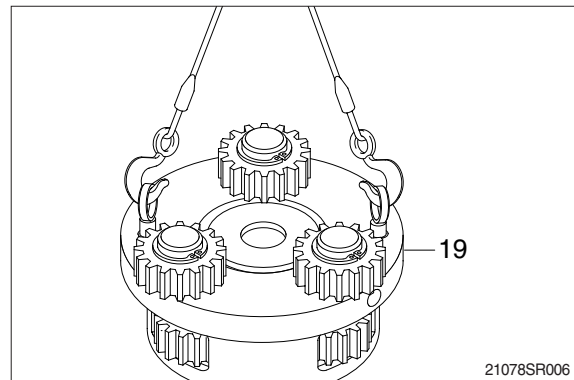

(7) Disassembling carrier1 (19) assembly.

- ① Remove stop ring (38).
 - ② Remove side plate2 (39), planet gear1 (24), needle cage (22) and side plate1 (20) and side plate3 (26) from the carrier.
 - ③ Using M8 solid drill, crush spring pin (17) so that the pin1 (21) can be removed by hammering.
 - ④ Remove side plate3 (26) from carrier1 (19).
- ※ Do not reuse spring pin (17).
 - ※ Do not remove pin1 (21), carrier1 (19) and spring pin (17) but in case of replacement.
 - ※ Put matching marks on the planet gear1 (24) and the pin1 (21) for easy reassembly.

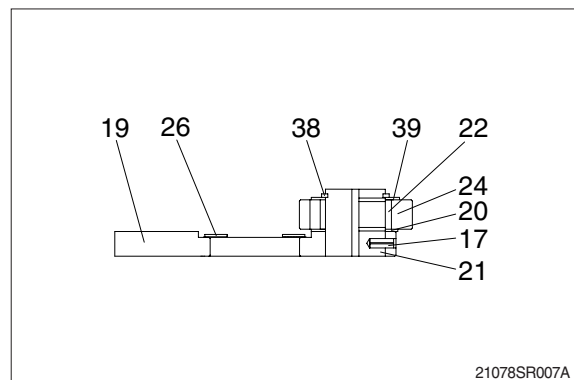

(8) Remove sun gear2 (18) and thrust washer (14).

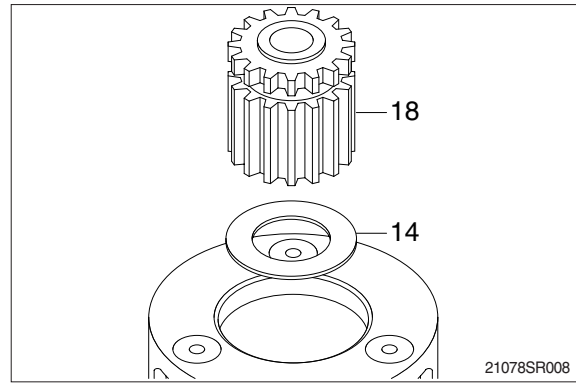

(9) Remove carrier2 (9) assembly from casing (1).

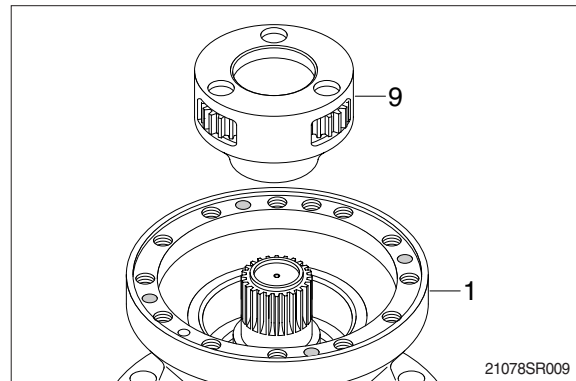

(10) Disassembling carrier2 (9) assembly

① Using M8 solid drill, crush spring pin (17) so that the pin & bushing (16) can be removed.

※ Do not reuse spring pin (17).

② Remove pin & bushing (16), planet gear2 (15) and bushing2 (23) from the carrier2 (9).

※ Put matching marks on the planet gear2 (15) and the pin & bushing (16) for easy reassembly.

※ Do not disassemble pin & bushing (16), carrier2 (9) and spring pin (17) but in case of replacement.

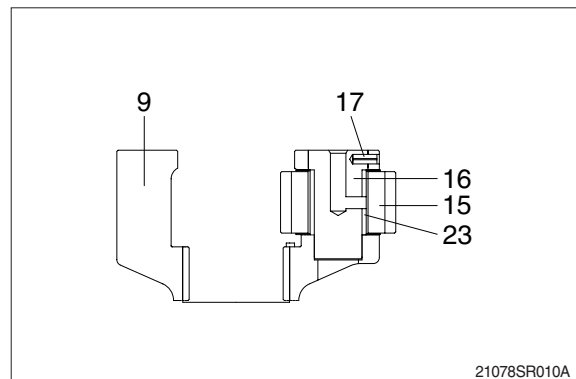

(11) Remove thrust plate (8) and stop ring (10) from the drive shaft (2).

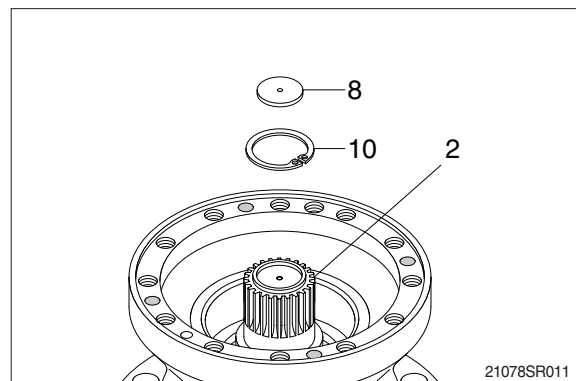

- (12) Remove drive shaft (2) with roller bearing (7) and oil seal (6) assembled.
Remove knock pin (12) from the casing (1).

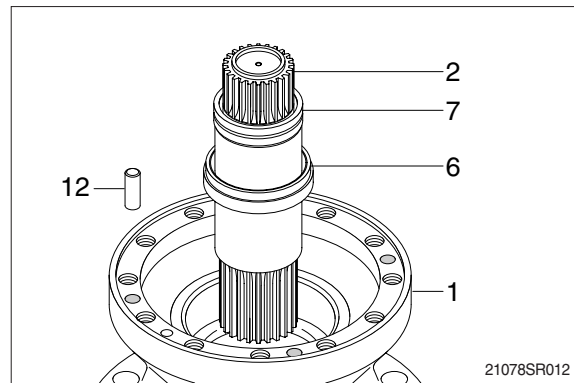

- (13) Remove roller bearing (7) and oil seal (6) from the drive shaft (2).
※ Do not reuse oil seal (6) once removed.

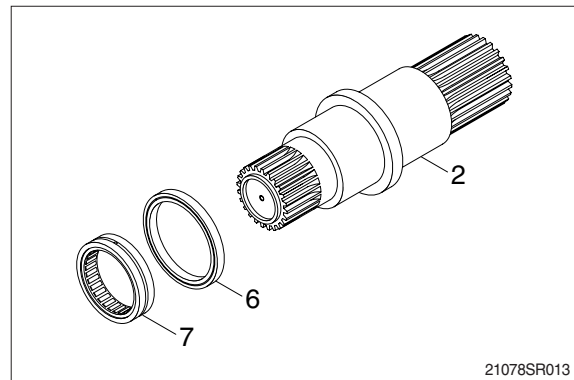

- (14) Using the bearing disassembly tool, remove roller bearing (5).

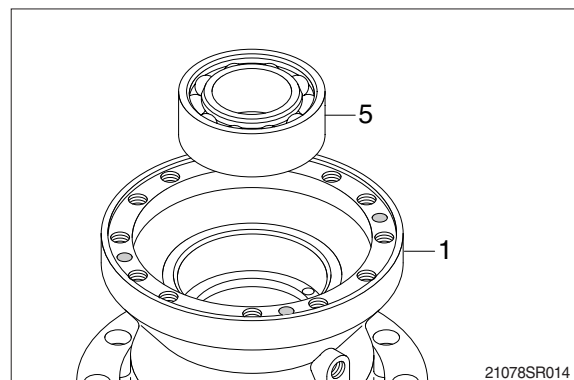

- (15) Remove plugs (29, 30) from the casing (1).

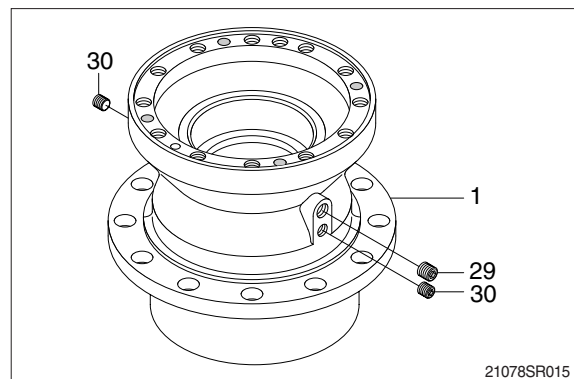

3) ASSEMBLY

- (1) Assemble roller bearing (5) inside the casing (1).

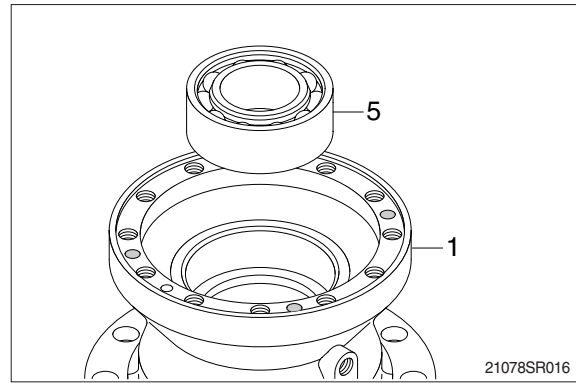

- (2) Assemble the drive shaft (2) into the casing (1) and then install oil seal (6) and roller bearing (7).

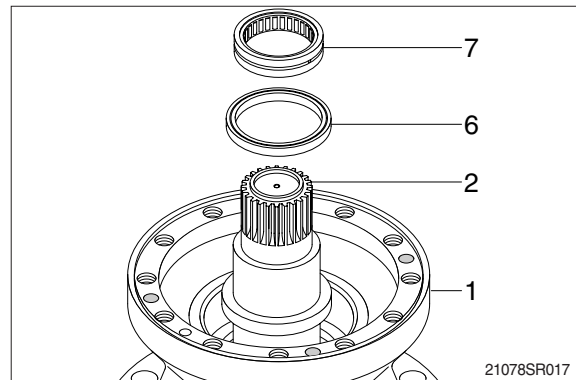

- (3) Install stop ring (10) and thrust plate (8) on top of drive shaft (2).

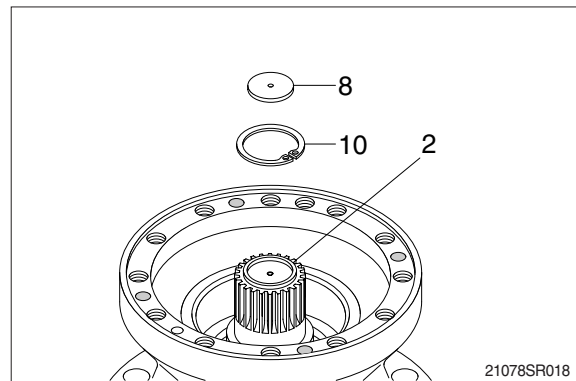

- (4) Assembling carrier2 (9) assembly.

- ① Install thrust washer (14) inside the carrier2 (9).
 - ② Install bushing2 (23) inside the planet gear2 (15) and then assemble them to the carrier2 (9).
 - ③ Assemble the pin & bushing (16) to the carrier2 (9) and then press the spring pin (17) by hammering.
 - ④ Punch 2 points of the spring pin (17) lip.
- ※ Take care not to mistake the matching marks of each part.

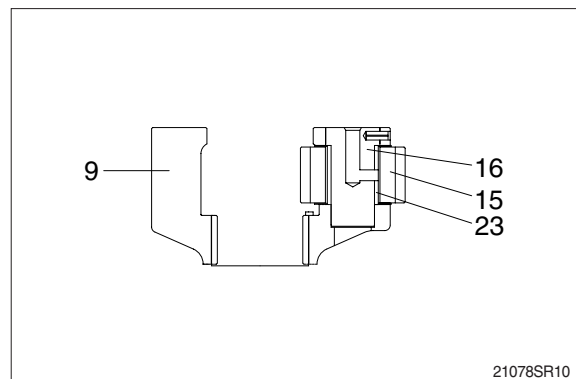

- (5) Assemble carrier2 (9) assembly correctly to the drive shaft (2).

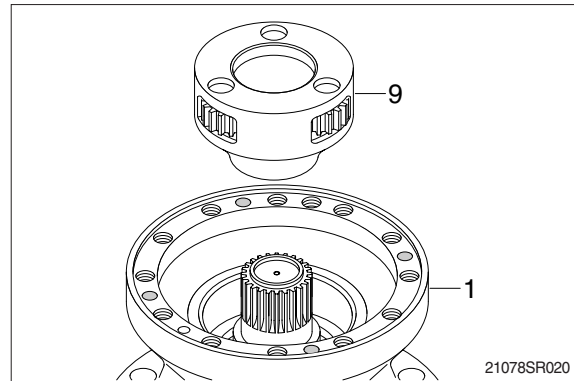

- (6) Assemble sun gear2 (18) and thrust washer (14) to the center of the carrier2 (9) assembly.

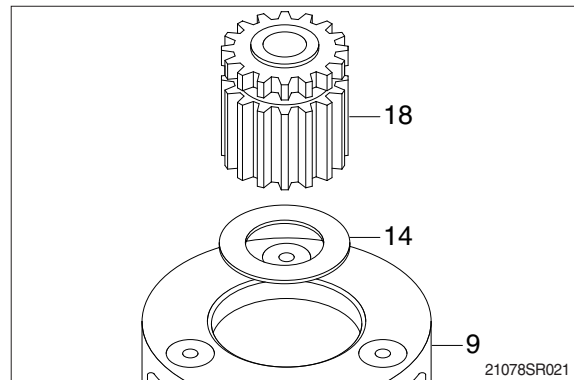

- (7) Assembling carrier1 (19) assembly.

- ① Assemble the pin1 (21) to the carrier1 (19) and then press the spring pin (17) by hammering.
 - ② Punch 2 points of the spring pin's (17) lip.
 - ③ Install side plate3 (26) onto the center of carrier1 (19).
 - ④ Install needle cage (22) into the planet gear1 (24).
 - ⑤ Assemble side plate (20), planet gear1 (24), side plate2 (39) and then stop ring (38) to the pin1 (21).
- ※ Take care not to mistake the matching marks of each part.

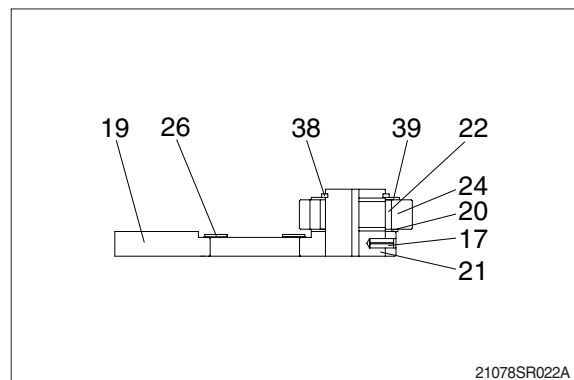

- (8) Install sun gear1 (27) onto the side plate3 (26).

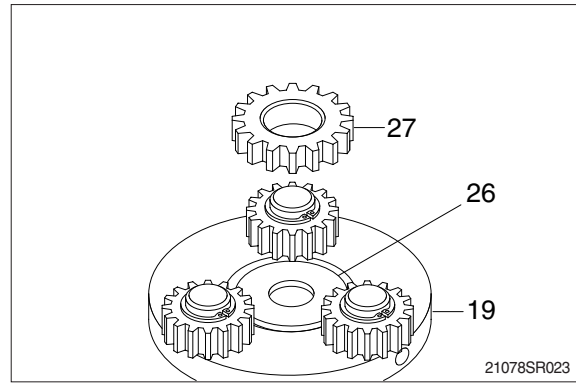

- (9) Assemble carrier 1 (19) assembly onto the carrier2 assembly.

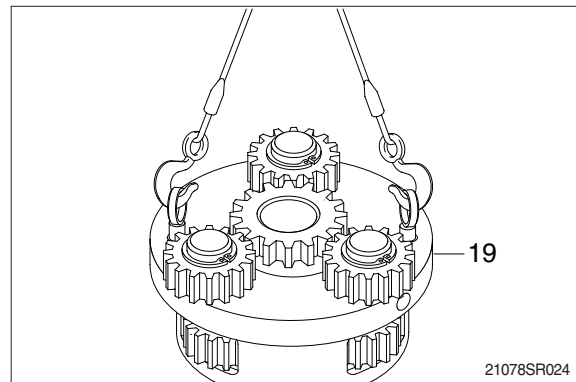

- (10) Apply loctite to the tapped holes of casing (1).

- (11) Tighten 3 M16 eye bolts to the ring gear (11) and lift up and then assemble it onto the casing (1).

- ※ Don't fail to coincide the knock pin (12) holes.

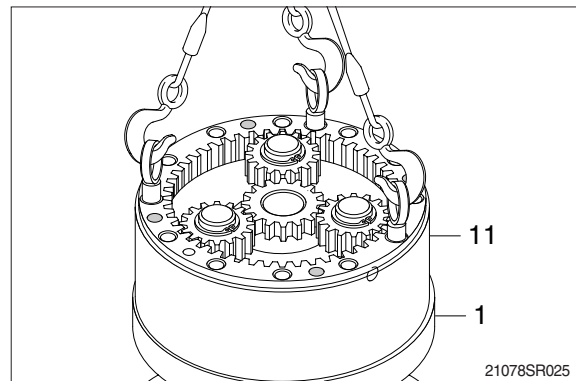

- (12) Hammer 4 knock pins (12) around the ring gear (11).

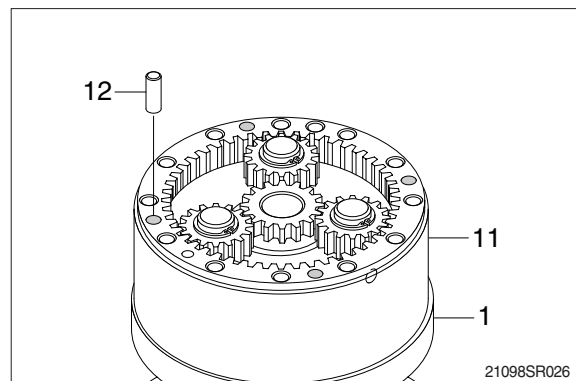

(13) Apply loctite to the tapped holes of the ring gear (11) and then mount swing motor onto the ring gear (11).

※ Don't fail to coincide the gauge bar (33) hole.

(14) Tighten socket bolts (31) around the swing motor assembly.

· Tightening torque : 24kgf · m (173lb · ft)

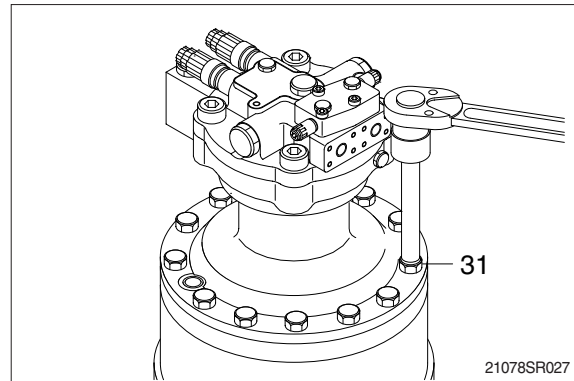

(15) Assemble plugs (29, 30).

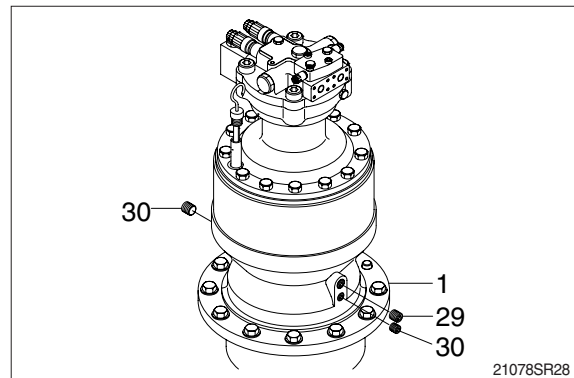

(16) Turn the swing motor assembly upside down and assemble cover plate (34) by tightening the hexagon bolts (35).

Install spacer (3) and pinion gear (13) to the drive shaft (2).

Assemble lock plate (36) on the pinion gear (13).

Assemble 2 lock washers (25) on the lock plate (36) with their 2 hole coincided individually to the tapped holes of drive shaft (2).

Tighten hexagon bolts (37) to the drive shaft (2) and then fold all the lock washer (25) corners over the hexagon bolts (37).

· Tightening torque : 24kgf · m (173lb · ft)

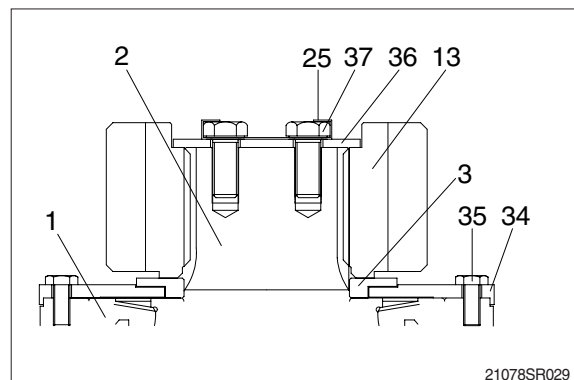

(17) Inject oil into the reduction gear.

GROUP 5 SWING DEVICE (TYPE 2)

1. REMOVAL AND INSTALL OF MOTOR

1) REMOVAL

- (1) Lower the work equipment to the ground and stop the engine.
- (2) Operate the control levers and pedals several times to release the remaining pressure in the hydraulic piping.
- (3) Loosen the breather slowly to release the pressure inside the hydraulic tank.

▲ Escaping fluid under pressure can penetrate the skin causing serious injury.

※ When pipes and hoses are disconnected, the oil inside the piping will flow out, so catch it in oil pan.

- (4) Disconnect hose assembly (2).
- (5) Disconnect pilot line hoses (3, 4, 5, 6, 7, 8).
- (6) Sling the swing motor assembly (1) and remove the swing motor mounting socket bolts (9).

· Motor device weight : 61 kg (135 lb)

- (7) Remove the swing motor assembly.
※ When removing the swing motor assembly, check that all the piping have been disconnected.

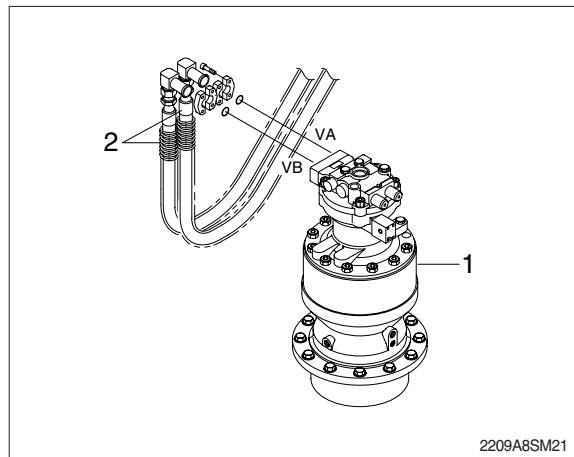

2) INSTALL

- (1) Carry out installation in the reverse order to removal.
- (2) Bleed the air from the swing motor.
 - ① Remove the air vent plug.
 - ② Pour in hydraulic oil until it overflows from the port.
 - ③ Tighten plug lightly.
 - ④ Start the engine, run at low idling and check oil come out from plug.
 - ⑤ Tighten plug fully.
- (3) Confirm the hydraulic oil level and check the hydraulic oil leak or not.

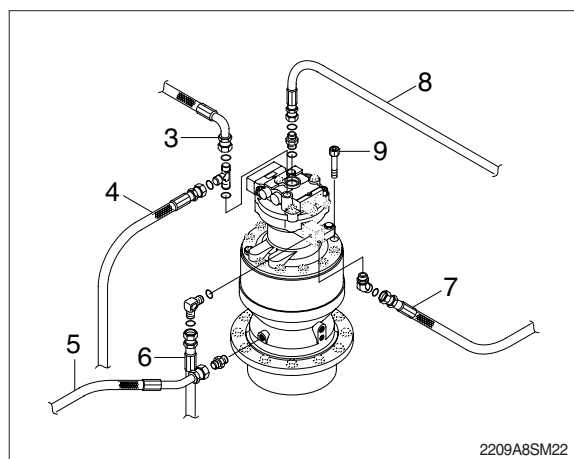

2. DISASSEMBLY AND ASSEMBLY OF SWING MOTOR

1) STRUCTURE

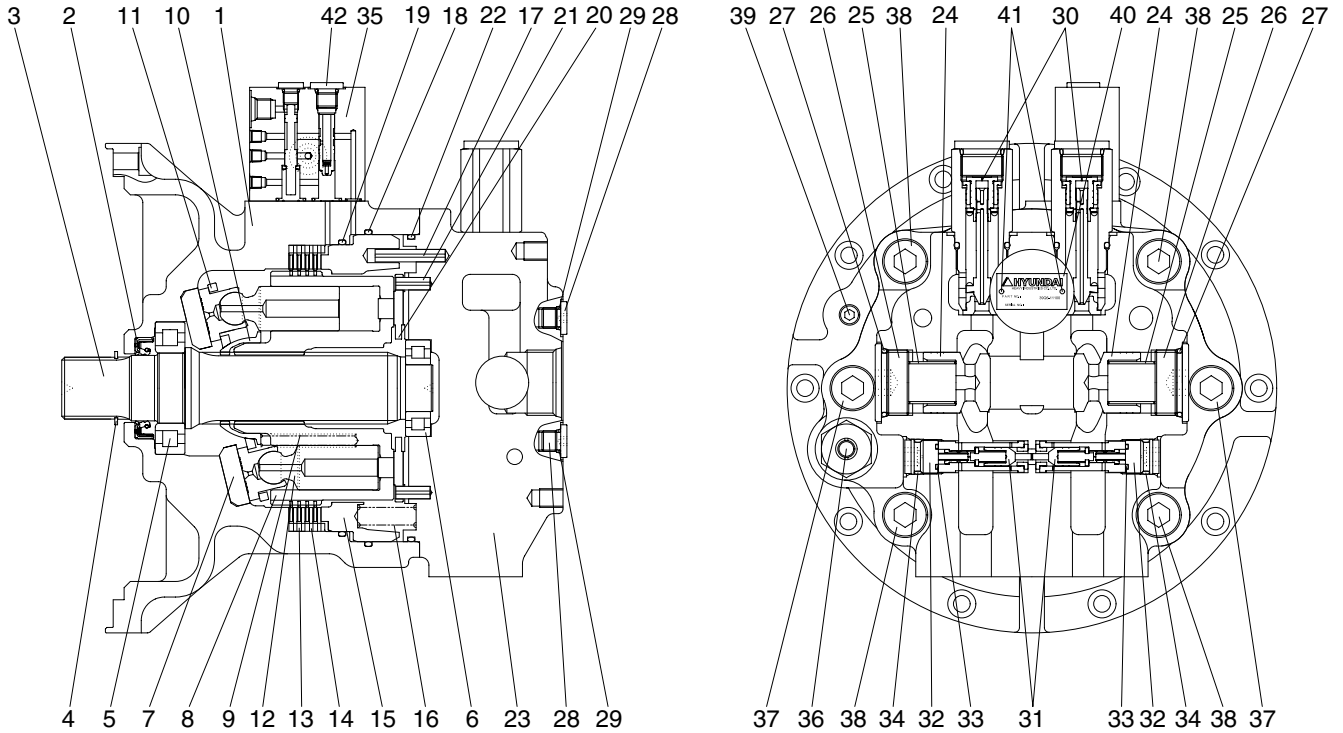

2209A6SM23

1	Casing	15	Parking piston	29	O-ring
2	Oil seal	16	Spring	30	Relief valve assy
3	Shaft	17	Spring pin	31	Reactionless valve assy
4	Snap ring	18	O-ring	32	Plug
5	Roller bearing	19	O-ring	33	O-ring
6	Needle bearing	20	Valve plate	34	O-ring
7	Swash plate	21	Spring pin	35	Time delay valve assy
8	Cylinder block	22	O-ring	36	Level gauge
9	Spring	23	Valve casing	37	Socket bolt
10	Ball guide	24	Check valve	38	Socket bolt
11	Retainer plate	25	Spring	39	Plug
12	Piston assy	26	Plug	40	Name plate
13	Friction plate	27	O-ring	41	Rivet
14	Separate plate	28	Plug	42	Socket bolt

2) DISASSEMBLY

(1) Disassemble drive shaft

- ① Unloosing socket bolt (time delay valve, 42) and disassemble time delay valve assy (35) from casing (1).



2209A8SM51

- ② Disassemble level gauge (36) from casing (1).



2209A8SM52

- ③ Hang valve casing (23) on hoist, unloose socket bolt (37, 38) and disassemble from casing (1).



2209A8SM53

- ④ Disassemble spring (16) and using a jig, disassemble parking piston (15) from casing (1).

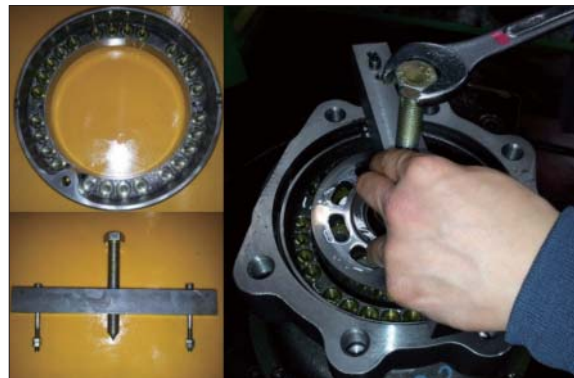

2209A8SM54

- ⑤ Disassemble respectively cylinder block sub (8), friction plate (13), separate plate (14) from casing (1).



2209A8SM55

- ⑥ Disassemble swash plate (7) from casing (1).



2209A8SM56

- ⑦ Using a plier jig, disassemble snap ring (4) from casing (1).



2209A8SM57

- ⑧ Disassemble shaft assy (3), oil seal (2) and O-ring (18, 22) from casing (1).



2209A8SM58

(2) Disassemble cylinder block sub

- ① Disassemble piston assy (12) from cylinder block (8).



2209A8SM59

- ② Disassemble ball guide (10) and spring (cylinder block, 9) from cylinder block (8).
 - Ball guide × 1EA
 - Spring × 9EA



2209A8SM60

(3) Disassemble valve casing sub

- ① Disassemble spring pin (17, 21), valve plate (20), O-ring (22) from valve casing (23).



2209A8SM61

- ② Using a torque wrench, disassemble relief valve (30) from valve casing (23).



2209A8SM62

- ③ Using a torque wrench, disassemble plug (32) from valve casing (23) and disassemble O-ring (33, 34) and reactionless valve assy (31).



2209A8SM63

- ④ Using a torque wrench, disassemble check valve (24) from valve casing (23).



2209A8SM64

- ⑤ Disassemble plug (28), O-ring (29) from valve casing (23).



2209A8SM65

3) ASSEMBLING

(1) Assemble shaft sub

- ① Put roller bearing (3) on preheater and provide heat to inner race.
(Temperature in conveyor : 120°C for 3~5 minutes)



2209A8SM66

- ② Using a robot machine, assemble and press preheated roller bearing (3) into shaft (5).



2209A8SM67

(2) Assemble cylinder block sub

- ① Assemble 9 springs (cylinder block, 9) into cylinder block (8).
 - Spring × 9EA



2209A8SM68

- ② Assemble ball guide (10) into cylinder block (8).
 - Ball guide × 1EA



2209A8SM69

- ③ Assemble 9 piston assy (12) into retainer plate (11).
- Piston assy × 9EA
 - Retainer plate × 1EA



2209A8SM70

- ④ Assemble parts of procedure ② and ③.



2209A8SM71

(3) Assemble valve casing sub

- ① Assemble make up check valve sub
Assemble check valve (24), O-ring (27), plug (26) in that order and then screw it torque wrench.
- Make up check valve × 2EA
 - Spring × 2EA
 - Plug × 2EA
 - O-ring × 2EA



2209A8SM72

- ② Assemble reactionless valve assy
Assemble reactionless valve assy (31), plug (32), O-ring (33, 34) in that order and then screw it a torque wrench.
- Reactionless valve assy (31) × 2EA
 - Plug (32) × 2EA
 - O-ring (33, 34) × 2EA



2209A8SM73

- ③ Using a torque wrench, assemble relief valve (30) 2 sets into valve casing (23).
- Relief valve (30) × 2EA



2209A8SM74

- ④ Assemble plug (28) and O-ring (27) into valve casing (23).
- Plug (28) × 3EA
 - O-ring (27) × 3EA



2209A8SM75

- ⑤ Assemble needle bearing (6) into valve casing (23) and assemble spring pin (17, 21) into valve casing (23).
- Needle bearing (6) × 1EA
 - Spring pin (17, 21) × 1EA



2209A8SM76

- ⑥ Apply some grease valve plate (20) and assemble it into valve casing (23).



2209A8SM77

(4) Assemble drive shaft sub

- ① Using a jig, assemble oil sealing (2) into casing (1).



2209A8SM78

- ② Fit shaft sub (shaft+roller bearing) into casing (1).



2209A8SM79

- ③ Using a plier jig, assemble snap ring (4) to shaft (3).
 - Snap ring × 1EA



2209A8SM80

- ④ Apply some grease swash plate (7) and assemble it into casing (1).
 - Swash plate × 1EA



2209A8SM81

- ⑤ Insert O-ring (18, 19) into casing (1).
- O-ring (18) × 1EA
 - O-ring (19) × 1EA



2209A8SM82

- ⑥ Assemble cylinder block (8) into casing (1).



2209A8SM83

- ⑦ Assemble separate plate (14) and friction plate (13) 4 sets into casing (1) and fit parking piston (15) into casing (1) by a jig or a press.
- Separate plate × 4EA
 - Friction plate × 4EA
 - Parking piston × 1EA



2209A8SM84

- ⑧ Assemble spring (parking piston, 16) into parking piston (15).
- Spring × 26EA



2209A8SM85

- ⑨ Lift up valve casing (23) on casing (1) by a crane and assemble it with socket bolts (37, 38).



2209A8SM86

- ⑩ Assemble level gauge (36) and plug (39) into casing (1).



2209A8SM87

- ⑪ Assemble time delay valve assy (35) into valve casing (23) with socket bolt (42).
- Time delay valve × 1EA
 - Socket bolt × 3EA



2209A8SM88

⑫ **Air pressing test**

Be sure of leakage, after press air into assembled motor and put it in water for 1 minute (pressure : 2 kgf/cm²).



2209A8SM89

⑬ **Leakage check**

Place motor on a bench tester and after cleaning motor by color check No.1, paint No.3 and be sure of leakage.



2209A8SM90

⑭ **Mount test bench**

Mounting motor a test bench, test the availability of each part.



2209A8SM91

3. DISASSEMBLY AND ASSEMBLY OF REDUCTION GEAR

1) STRUCTURE

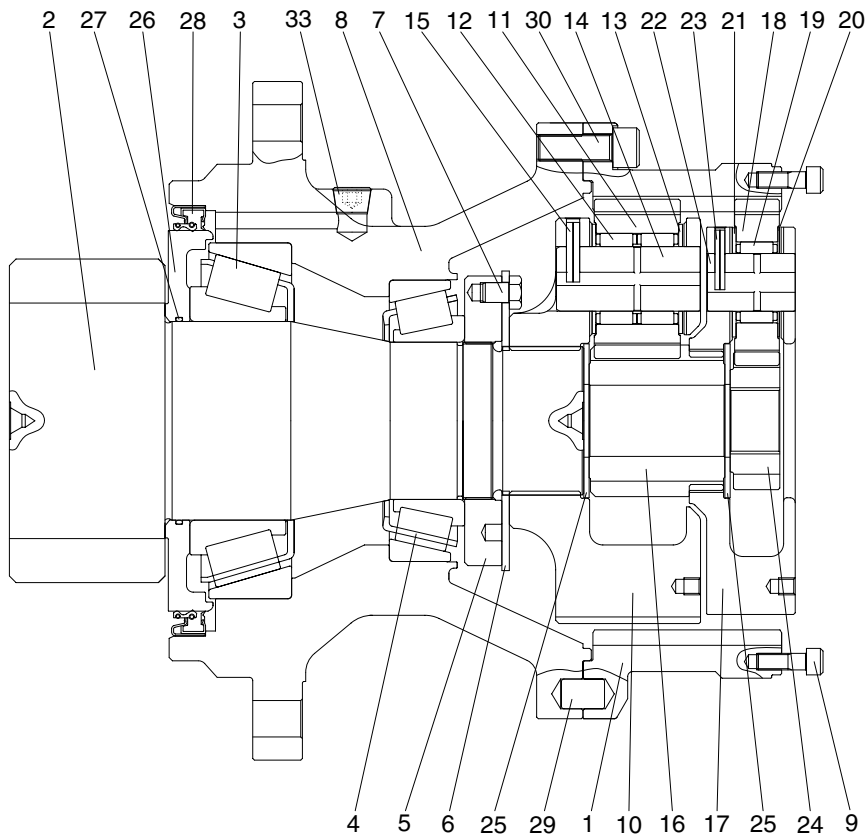

2209A2SM23

- | | | | | | |
|----|--------------|----|------------------|----|-----------------|
| 1 | Ring gear | 11 | Planetary gear 2 | 21 | Thrust washer 1 |
| 2 | Drive shaft | 12 | Needle bearing 2 | 22 | Carrier pin 1 |
| 3 | Bearing | 13 | Thrust washer 2 | 23 | Spring pin |
| 4 | Bearing | 14 | Carrier pin 2 | 24 | Sun gear 1 |
| 5 | Ring nut | 15 | Spring pin | 25 | Thrust plate |
| 6 | Lock plate | 16 | Sun gear 2 | 26 | Sleeve |
| 7 | Hexagon bolt | 17 | Carrier 1 | 27 | O-ring |
| 8 | Casing | 18 | Planetary gear 1 | 29 | Parallel pin |
| 9 | Socket bolt | 19 | Needle bearing 1 | 30 | Socket bolt |
| 10 | Carrier 2 | 20 | Thrust washer 1 | 33 | Plug |

2) DISASSEMBLY

(1) Preparation

- ① The reduction gear removed from machine is usually covered with mud.
Wash out side of reduction gear and dry it.
 - ② Setting reduction gear on work stand for disassembling.
 - ③ Mark for mating
Put marks on each mating parts when disassembling so as to reassemble correctly as before.
- ▲ Take great care not to pinch your hand between parts while disassembling not let fall parts on your foot while lifting them.

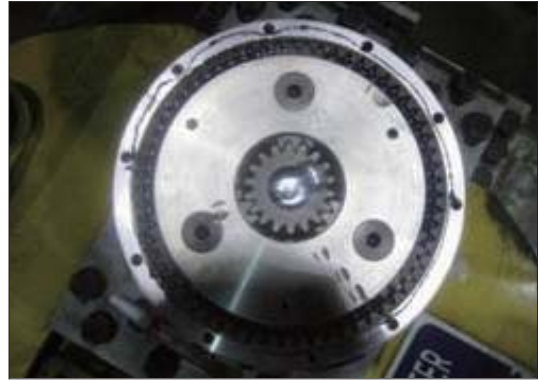

2209A8SM01

(2) Disassembly

- ① Remove every "Socket bolt (M10)" that secure swing motor and reduction gear.
- ② Removing carrier sub assy & sun gear
 - a. Removing No.1 sun gear from No.1 carrier sub assy.
※ Be sure maintaining it vertical with ground when disassembling No.1 sun gear.



2209A8SM02

- b. Removing No.1 carrier sub assy screwing I-bolt to tab hole (M10) in No.1 carrier.
Lifting it gradually maintaining it vertical with ground.
※ It's impossible to disassemble No.1 spring pin. If No.1 spring pin has problem, change whole No.1 carrier sub assy.



2209A8SM03

- c. Removing No.2 sun gear from No.2 carrier sub assy.
- ※ Be sure maintaining it vertical with ground when disassembling No.2 sun gear.



2209A8SM04

- d. Removing No.2 carrier sub assy screwing I-bolt to tab hole (M10) in No.2 carrier. Lifting it gradually maintaining it vertical with ground.
- ※ It's impossible to disassemble No.2 spring pin. If No.2 spring pin has problem, change whole No.2 carrier sub assy.



2209A8SM05

③ **Removing ring gear**

After unscrewing every socket bolt (M16), remove ring gear from casing.

- ※ Because of liquid gaskets between ring gear and casing, put sharp punch between ring gear and casing and tapping it to remove them.



2209A8SM06

④ **Removing drive shaft sub assy**

- Unscrew every hex head bolt (M12) to remove lock plate.

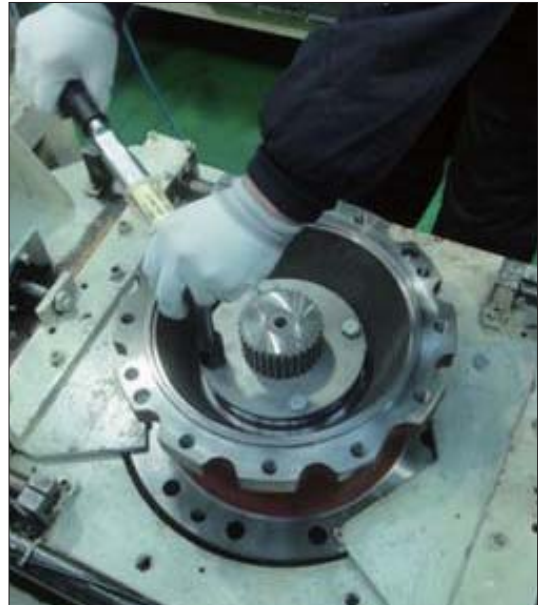

2209A8SM07

- Rolling ring nut for removing them from drive shaft sub assy.

- ※ Use special tool to roll ring nut to counter clockwise.

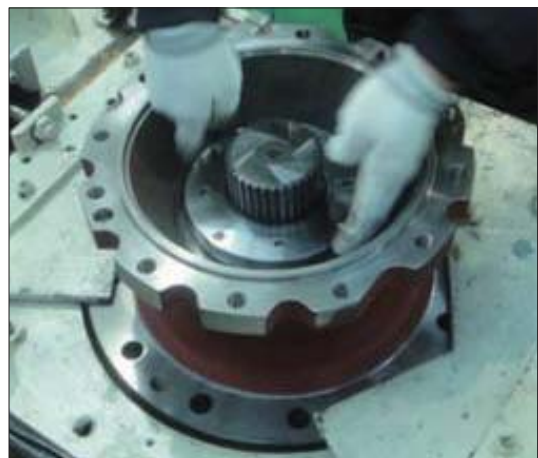

2209A8SM08

- c. Remove drive shaft sub assy from casing.
※ Set a rack for flange of casing, and remove drive shaft sub assy from casing by using press.



2209A8SM09

- d. Remove oil seal & taper bearing (small) from casing.
※ Do not re-use oil seal. It is impossible to disassemble drive shaft sub assy.



2209A8SM10



2209A8SM11

4. ASSEMBLY REDUCTION UNIT

1) GENERAL NOTES

- (1) Clean every part by kerosene and dry them in a cool and dry place.
- (2) Loctite on surface must be removed by solvent.
- (3) Check every part for any abnormal.
- (4) Each hexagon socket head bolt should be used with loctite #242 applied on its threads.
- (5) Apply gear oil slightly on each part before assembling.

▲ Take great care not to pinch your hand between parts or tools while assembling nor let fall parts on your foot while lifting them.

Inspection before assembling.

Thrust washer

- Check the seizure, abnormal wear or uneven wear.
- Check the unallowable wear.

Gear

- Check the pitting or seizure on tooth surface.
- Check the cracks on the root of tooth.

Bearing

- Rotate it by hands to check such noise or uneven rotation.

2) ASSEMBLING NO.1 CARRIER SUB ASSY

- (1) Put thrust plate firmly in No.1 carrier.
- (2) After assembling No.1 needle bearing to No.1 planetary gear, put a pair of No.1 thrust washer on both sides of bearing and install them to No.1 carrier.



2209A8SM12



2209A8SM13

- (3) Make of spring pin hole No.1 pin and No.1 carrier of spring pin hole in line, press No.1 spring pin into the holes.
 Make No.1 spring pin hole head for No.1 planetary gear.



2209A8SM14

- (4) Caulk carrier holes to make No.1 spring pin settle down stably.



2209A8SM15

- ※ Refer to “Caulking details”
 Use paint marker for marking after caulking.

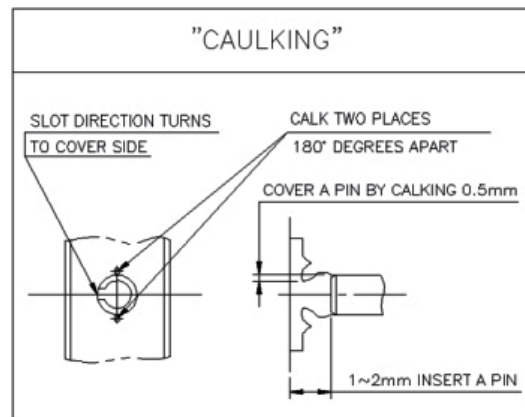

2209A8SM16

2) ASSEMBLING NO.2 CARRIER SUB ASSY

(1) Put thrust plate in firmly No.2 carrier.



2209A8SM17

(2) After assembling No.2 needle bearing to No.2 planetary gear, put 2 pieces of No.2 thrust washer on both sides of bearing and install them to No.2 carrier.



2209A8SM18

(3) Align No.2 spring pin hole and No.2 carrier spring pin hole, put No.2 spring pin into the holes.
Make No.2 spring pin cutting line face to No.2 planetary gear.



2209A8SM19

(4) Caulk carrier holes to make No.2 spring pin settle down stably.

※ Refer to “Caulking details”

Use paint marker for marking after caulking.

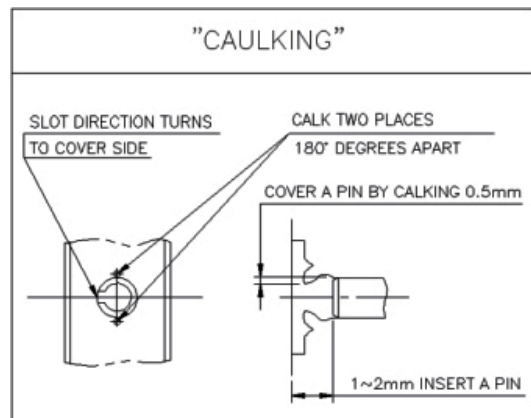

2209A8SM20

3) ASSEMBLING PINION GEAR SUB ASSY

- (1) Prepare drive shaft pinion gear vertical with ground.



2209A8SM21

- (2) Fully apply grease (albania EP02) to O-ring groove of sleeve.
※ Be sure to maintain it vertical with ground when assembling it.
- (3) Put O-ring into O-ring groove of sleeve.
Fully apply grease on O-ring.

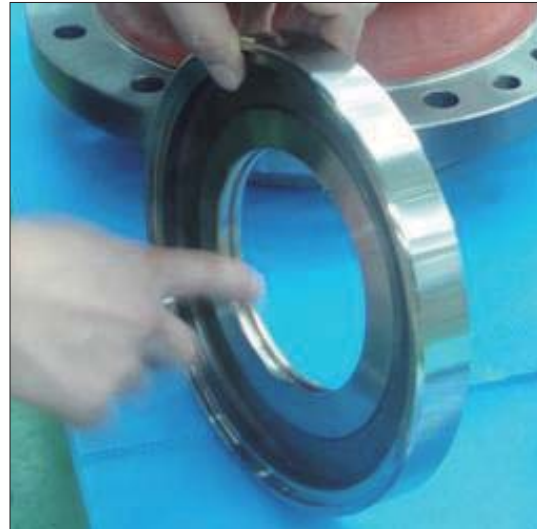

2209A8SM22

- (4) Assemble taper bearing and sleeve into drive shaft using press jig.
Use special jig for pressing. Leave no space between sleeve and taper bearing.



2209A8SM23



2209A8SM24

4) ASSEMBLING BEARING CUP & OIL SEAL (PRESSING)

- (1) Put top, bottom bearing cup into casing.
Use special jig for pressing. Pay attention to foreign materials while assembling bearing cup.
- ※ Flip over casing to assemble oil seal.



2209A8SM25



2209A8SM26

- (2) Assemble oil seal to casing.
Use special jig for pressing. Pay attention to direction of dust seal and dent.



2209A8SM27

※ WHILE ASSEMBLING OIL SEAL

1. Be sure to set dust seal to gear oil.
2. Before assembling, charge enough grease in oil seal.
3. Before assembling, apply enough grease inside and outside of oil seal.



2209A8SM28

5) ASSEMBLING SHAFT SUB ASSY & RING NUT

- (1) After assembling casing & drive shaft sub
assy, flip it over.



2209A8SM29

- (2) Put drive shaft sub assy into casing.
※ Be sure to maintain it vertical with ground when assembling it.



2209A8SM30

- (3) Put taper bearing into it.
Rotate bearing by hands for checking after assembly.



2209A8SM31

- (4) Put ring nut into drive shaft sub assy by using special jig.

The tightening torque (M95) = 3.5 ± 0.4 kgf·m
(25.3 ± 2.9 lbf·ft)



2209A8SM32

- ※ Apply enough loctite #242 before screwing bolts.



2209A8SM33

- (5) Align bolt screw of ring nut with lock plate's hole.

In case of misalign between bolt screw ring nut and lock plate's hole, put lock plate as near as possible to hole of bolt screw of ring nut and make it in line by increasing tightening torque.



2209A8SM34



2209A8SM35

- (6) Screw 4 bolts (M12 × 16) to connect ring nut and lock plate by using torque wrench.

Bolt (M12, 4EA) = 10.9T

The tightening torque = 8.8 ± 0.9 kgf·m
(63.7 ± 6.5 lbf·ft)

- ※ Apply enough loctite #242 before screwing bolts.

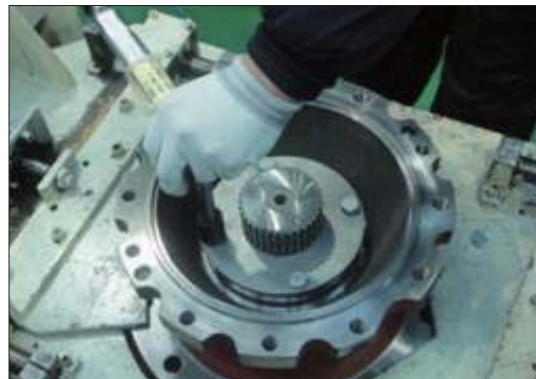

2209A8SM36

- (7) Use paint marker for checking surplus parts after assembling.



2209A8SM37

6) ASSEMBLING RING GEAR

- (1) Apply loctite #515 bottom of casing sub assy contacting with ring gear without disconnection.



2209A8SM38

Refer to loctite detail.

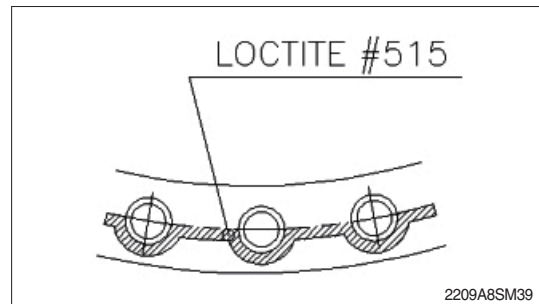

2209A8SM39

- (2) Put parallel pin into hole of casing sub assy.
Mark parallel pin position using paint marker.



2209A8SM40

- (3) Align ring gear with parallel pin to put them into casing sub assy.
※ Be sure to maintain them vertical with ground while using press.



2209A8SM41

- (4) Screw 12 bolts (M16×45) to connect casing sub assy and ring gear (01) by using torque wrench.

Bolt (M16, 12EA) = 12.9T

The tightening torque = 27 ± 2.7 kgf-m
(195 ± 19.5 lbf-ft)

- ※ Apply enough loctite #242 before screwing bolts.



2209A8SM42

- (5) Use paint marker for checking surplus parts after assembling.



2209A8SM43



2209A8SM44

7) ASSEMBLING CARRIER SUB ASSY & SUN GEAR

- (1) Put No.2 carrier sub assy along spline of drive shaft spline.
- Screw M10 I-bolt to No.2 carrier sub assy.
 - Lifting up No.2 carrier sub assy and align planetary gear and tooth of ring gear by rotating planetary gear by hands.
 - Rotate No.2 carrier sub assy by hands to fit No.2 carrier sub assy into drive shaft spline.



2209A8SM45

- (2) Put No.2 sun gear into No.2 carrier sub assy.



2209A8SM46

- (3) Put No.1 carrier sub assy into No.2 sun gear along spline.
- Screw M10 I-bolt to No.1 carrier sub assy.
 - Lifting up No.1 carrier sub assy and align planetary gear and tooth of ring gear by rotating planetary gear by hands.
 - Rotate No.1 carrier sub assy by hands to fit No.1 carrier into No.2 sun gear spline.



2209A8SM47

- (4) Put No.1 sun gear into No.1 carrier sub assy. Be sure to maintain it vertical with ground. And align with No.1 planetary gear spline.
- (5) Rotate No.1 carrier sub assy by hands to check noise.



2209A8SM48

8) MEASURING CLEARANCE & ASSEMBLING NAME PLATE

- (1) Check the clearance between ring gear and No.1 sun gear using a tool with dial gauge.

Check the clearance
Dial gauge = -0.3 ~ +2.95



2209A8SM49