

SECTION 3 HYDRAULIC SYSTEM

Group 1 Hydraulic Circuit	3-1
Group 2 Main Circuit	3-2
Group 3 Pilot Circuit	3-5
Group 4 Single Operation	3-13
Group 5 Combined Operation	3-23

SECTION 3 HYDRAULIC SYSTEM

GROUP 1 HYDRAULIC CIRCUIT

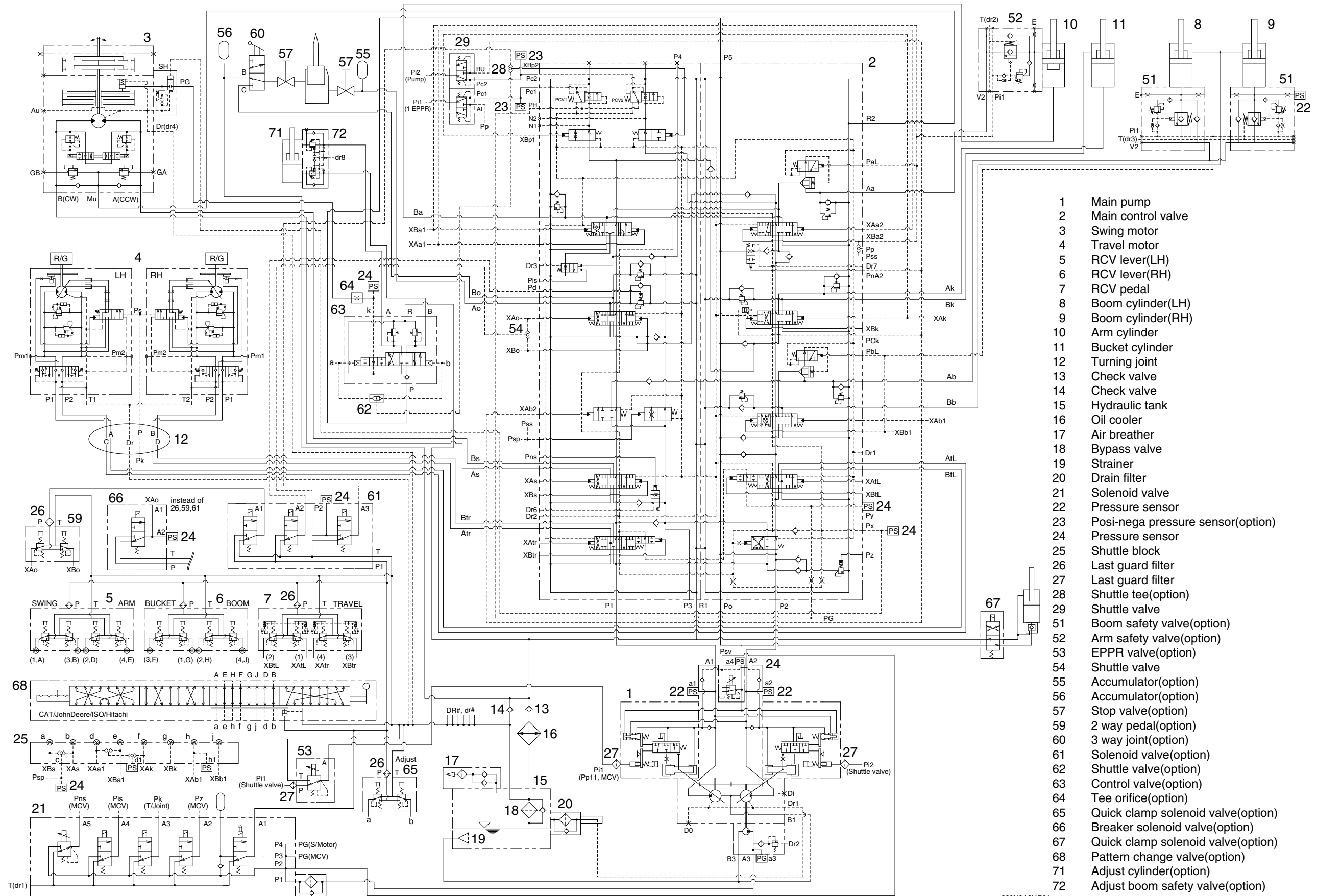

- 1 Main pump
- 2 Main control valve
- 3 Swing motor
- 4 Travel motor
- 5 RCV lever(LH)
- 6 RCV lever(RH)
- 7 RCV pedal
- 8 Boom cylinder(LH)
- 9 Boom cylinder(RH)
- 10 Arm cylinder
- 11 Bucket cylinder
- 12 Turning joint
- 13 Check valve
- 14 Check valve
- 15 Hydraulic tank
- 16 Oil cooler
- 17 Air breather
- 18 Bypass valve
- 19 Strainer
- 20 Drain filter
- 21 Solenoid valve
- 22 Pressure sensor
- 23 Posi-nega pressure sensor(option)
- 24 Pressure sensor
- 25 Shuttle block
- 26 Last guard filter
- 27 Last guard filter
- 28 Shuttle tee(option)
- 29 Shuttle valve
- 51 Boom safety valve(option)
- 52 Arm safety valve(option)
- 53 EPPR valve(option)
- 54 Shuttle valve
- 55 Accumulator(option)
- 56 Accumulator(option)
- 57 Stop valve(option)
- 59 2 way pedal(option)
- 60 3 way joint(option)
- 61 Solenoid valve(option)
- 62 Shuttle valve(option)
- 63 Control valve(option)
- 64 Tee orifice(option)
- 65 Quick clamp solenoid valve(option)
- 66 Breaker solenoid valve(option)
- 67 Quick clamp solenoid valve(option)
- 68 Pattern change valve(option)
- 71 Adjust cylinder(option)
- 72 Adjust boom safety valve(option)

220N9A3HC01