

GROUP 6 TRAVEL DEVICE (TYPE 1)

1. REMOVAL AND INSTALL

1) REMOVAL

- (1) Swing the work equipment 90° and lower it completely to the ground.
- (2) Operate the control levers and pedals several times to release the remaining pressure in the hydraulic piping.
- (3) Loosen the breather slowly to release the pressure inside the hydraulic tank.

▲ Escaping fluid under pressure can penetrate the skin causing serious injury.

※ When pipes and hoses are disconnected, the oil inside the piping will flow out, so catch it in oil pan.

- (4) Remove the track shoe assembly.
For details, see **removal of track shoe assembly**.
- (5) Remove the cover.
- (6) Remove the hose.
※ Fit blind plugs to the disconnected hoses.
- (7) Remove the bolts and the sprocket.
- (8) Sling travel device assembly (1).
- (9) Remove the mounting bolts (2), then remove the travel device assembly.
· Weight : 300 kg (660 lb)

2) INSTALL

- (1) Carry out installation in the reverse order to removal.
- (2) Bleed the air from the travel motor.
 - ① Remove the air vent plug.
 - ② Pour in hydraulic oil until it overflows from the port.
 - ③ Tighten plug lightly.
 - ④ Start the engine, run at low idling, and check oil come out from plug.
 - ⑤ Tighten plug fully.
- (3) Confirm the hydraulic oil level and check the hydraulic oil leak or not.

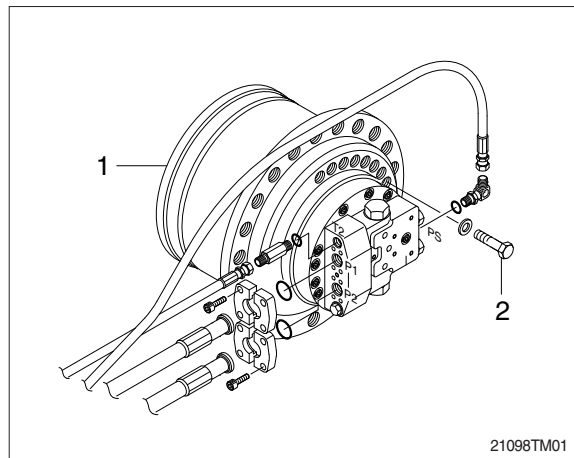

2. TRAVEL MOTOR

1) STRUCTURE

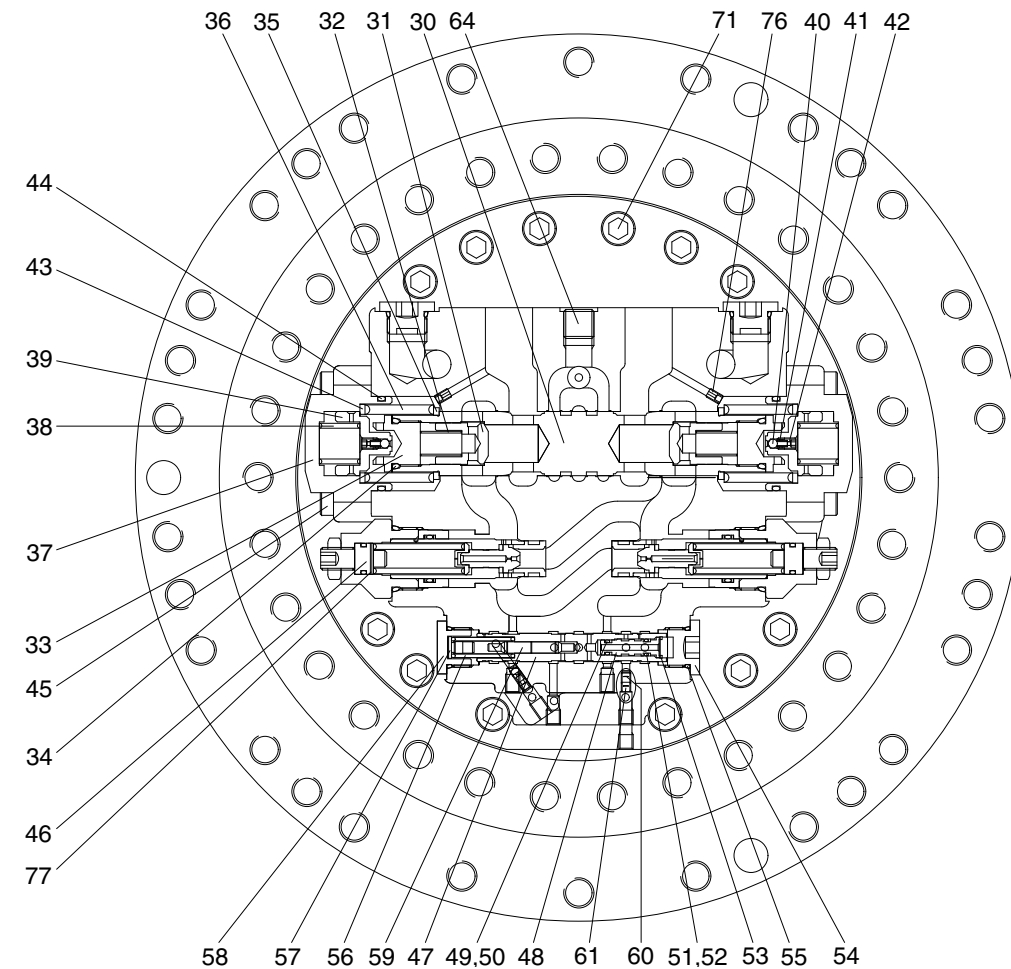
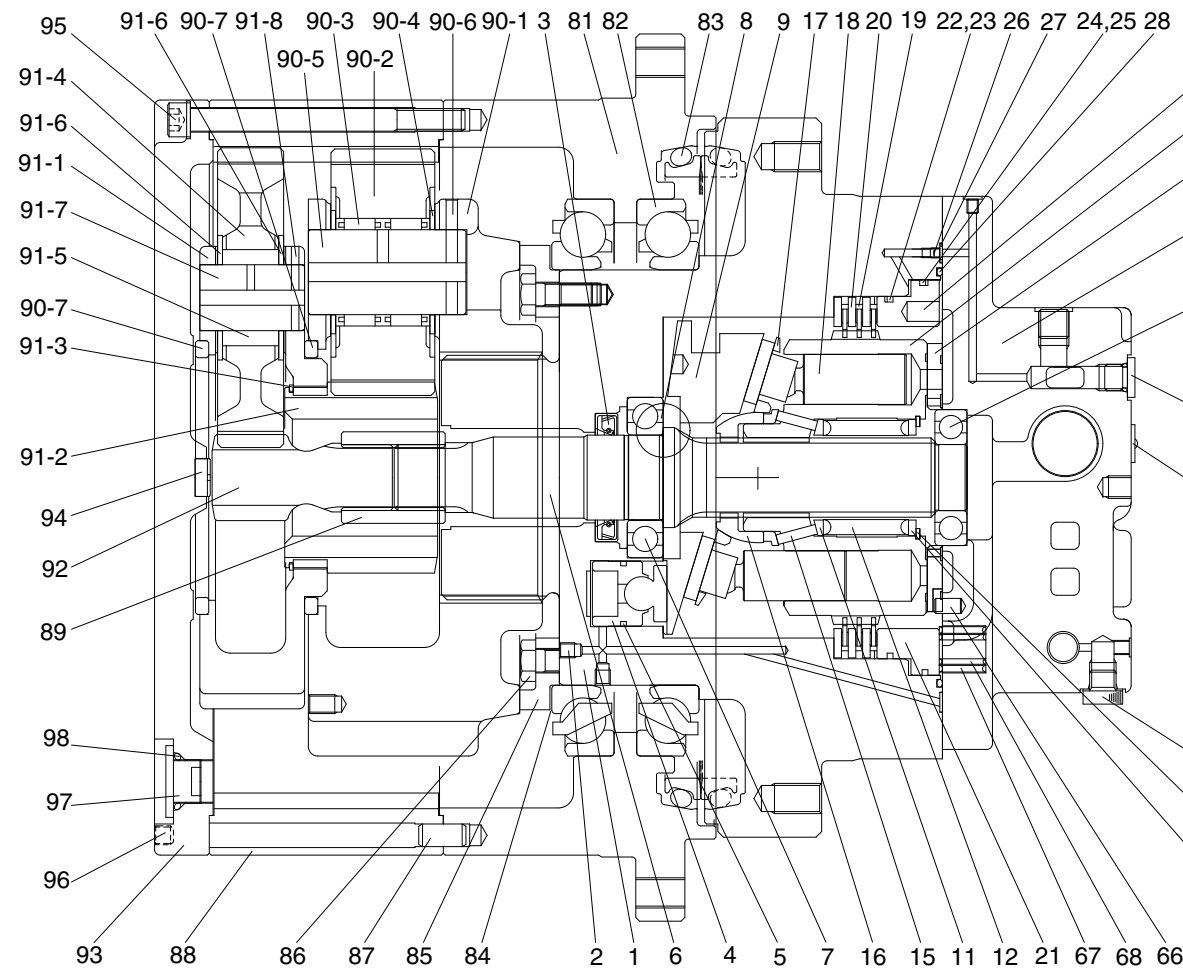

- | | | | | | |
|-------------------|-------------------|----------------------|----------------|--------------------------|--------------------------|
| 1 Shaft casing | 20 Plate | 39 Spool | 58 Plug | 76 Orifice | 90-7 Thrust ring |
| 2 Plug | 21 Parking piston | 40 Steel ball | 59 Spool | 77 Shim | 91 Carrier assy No.1 |
| 3 Oil seal | 22 O-ring | 41 Spring | 60 Orifice | 81 Housing | 91-1 Carrier No.1 |
| 4 Swash piston | 23 Back up ring | 42 Plug | 61 Orifice | 82 Main bearing | 91-2 Sun-gear No.2 |
| 5 Piston ring | 24 O-ring | 43 Spring seat | 62 Plug | 83 Floating seal | 91-3 Retaining ring |
| 6 Shaft | 25 Back up ring | 44 O-ring | 63 O-ring | 84 Shim | 91-4 Planetary gear No.1 |
| 7 Bearing | 26 Orifice | 45 Wrench bolt | 64 Plug | 85 Retainer | 91-5 Needle bearing No.1 |
| 8 Steel ball | 27 O-ring | 46 Relief valve assy | 65 Pin | 86 Hex head bolt | 91-6 Thrust washer |
| 9 Swash plate | 28 O-ring | 47 Spool | 66 Pin | 87 Parallel pin | 91-7 Pin No.1 |
| 10 Cylinder block | 29 Rear cover | 48 Guide | 67 Spring | 88 Ring gear | 91-8 Spring pin |
| 11 Spring seat | 30 Spool | 49 O-ring | 68 Spring | 89 Coupling | 92 Sun gear No.1 |
| 12 Spring | 31 Check | 50 Back up ring | 69 Bearing | 90 Carrier assy No.2 | 93 Cover |
| 13 End plate | 32 Spring | 51 O-ring | 70 Valve plate | 90-1 Carrier No.2 | 94 Pad |
| 14 Snap ring | 33 Plug | 52 Back up ring | 71 Wrench bolt | 90-2 Planetary gear No.2 | 95 Hex socket head bolt |
| 15 Pin | 34 O-ring | 53 Snap ring | 72 Plug | 90-3 Needle bearing No.2 | 96 Hex socket Screw |
| 16 Ball guide | 35 Spring seat | 54 plug | 73 Name plate | 90-4 Thrust washer | 97 Hydraulic plug |
| 17 Set plate | 36 Spring | 55 O-ring | 74 Rivet | 90-5 Pin No.2 | 98 O-ring |
| 18 Piston assy | 37 Cover | 56 Spring | 75 Seal kit | 90-6 Spring pin | 99 Name plate |
| 19 Friction plate | 38 Spring | 57 Spring seat | | | |

21092TM02

2) TOOLS AND TIGHTENING TORQUE

(1) Tools

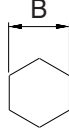
Tool name		Remark	
Allen wrench		2.5, 4, 6, 10	
Socket for socket wrench, spanner	Socket	8, 14, 24, 27	
Torque wrench		Capable of tightening with the specified torques	
Pliers		-	
Plastic and iron hammer		Wooden hammer allowed. Normal 1 or so	
Monkey wrench		-	
Oil seal inserting jig		-	
Bearing pliers		-	
Seal tape		-	
Eye bolt		M10, M12, M14	
Press (0.5 ton)		-	
Oil stone		-	
Bearing assembling jig		-	

(2) Tightening torque

Part name	Item	Size	Torque	
			kgf · m	lbf · ft
Plug	2	NPT 1/16	1±0.1	7.2±0.7
Orifice	26	M5	0.7±0.1	5±0.7
Wrench bolt	45	M12×40	10±1.0	72±7.0
Relief valve	46	HEX 27	18±1.0	130±7.0
Plug	54	PF 1/2	8.5±1.0	61±7.0
Plug	58	HEX 24	5±1.0	36±7.0
Plug	62	PF 1/4	5±1.0	36±7.0
Wrench bolt	71	M12×35	10±1.0	72±7.0
Hex head bolt	-	M12×25	11±1.5	79±10
Hex socket head bolt	-	M12×155	11±1.5	79±10
Hex socket head plug	-	PF 3/4	19±1	137±7.0

3. OUTLINE OF DISASSEMBLING

1) GENERAL SUGGESTIONS

- (1) Select a clean place for dismantling.
Spread a rubber plate on a working table in order to prohibit the damage of parts.
- (2) Clean a deceleration equipment and a motor part, washing out dirt and unnecessary substances.
- (3) Without any damage of O-ring, oil seal, the adhered surface of other seals, a gear, a pin, the adhered surface of other bearings, and the surface of moisturized copper, treat each parts.
- (4) Numbers written in the parenthesis, (), next to the name of a part represent the part numbers of a cross-sectional view annexed with a drawing.
- (5) The side of a pipe in a motor can be written as a rear side; the side of out-put as a front side.
- (6) Using and combining a liquid gasket, both sides must be dried completely before spraying a liquid gasket.
- (7) In case of bonding bolts, combine a standard torque by torque wrench after spraying loctite 262 on the tab parts. (It can be dealt as assembling NPTF screws and an acceleration equipment.)

3.1 DISASSEMBLING

- 1) Unloosing wrench bolt and disassemble cover (37).
※ Wrench bolt = M12 × 40L-8EA
(purchasing goods)

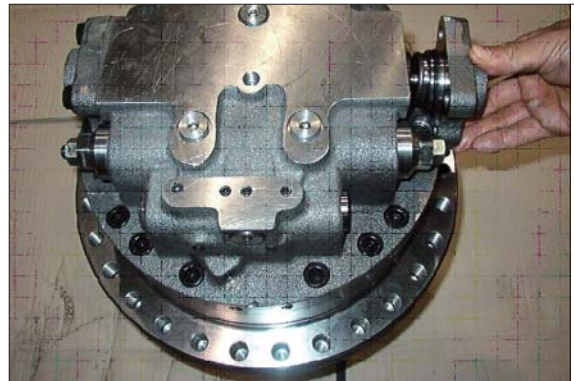

21078TM21

- 2) Disassemble parts related to C.B.V.



21078TM22

- 3) Unloosing wrench bolt (M12×35L, 16EA) and disassemble rear cover assembly from motor assembly.

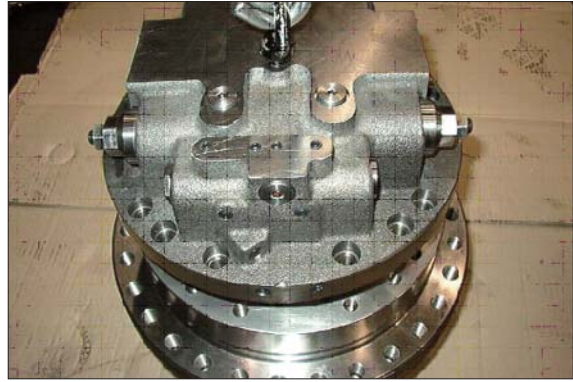

21078TM23



21078TM24

- 4) Dismantle packing piston (21) using compressed air.



21078TM25

- 5) Disassembly rotary kit from motor assembly (cylinder block assembly, piston assembly, ball guide, set plate, friction plate, steel plate...)

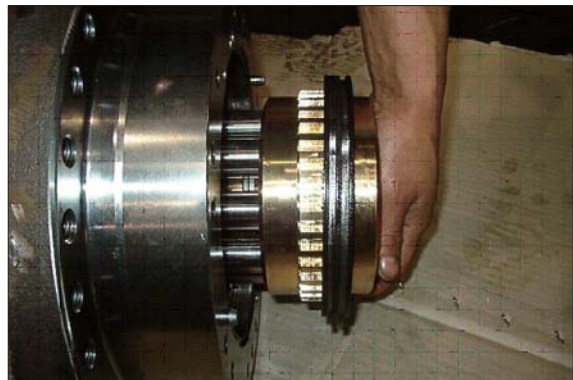

21078TM26

6) Using a jig, disassemble swash plate (9) from shaft casing.



21078TM27

7) Using compressed air, disassemble piston swash (4) piston ring (5), respectively.



21078TM28



21078TM29

8) Using a hammer, disassemble shaft (6) from shaft casing (1).

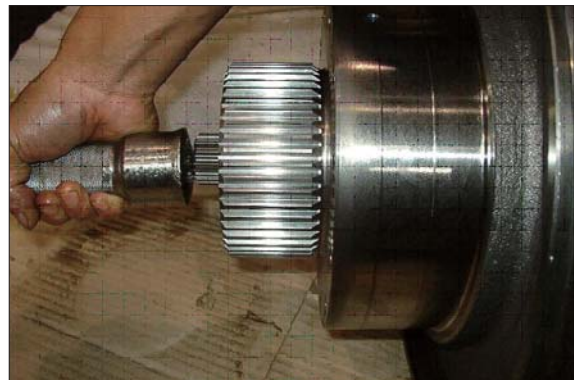

21078TM30

■ Disassemble cylinder sub.

9) Disassemble cylinder block assembly, piston assembly (9) and seat plate (M).



21078TM31



21078TM32

10) Disassemble ball guide (16), ring and pin (15) from cylinder block, respectively.



21078TM33



21078TM34



21078TM35

- 11) Pushing spring (12) by an assembling jig, disassemble snap ring (14), spring seat (13), spring (12) and spring seat (11), respectively.

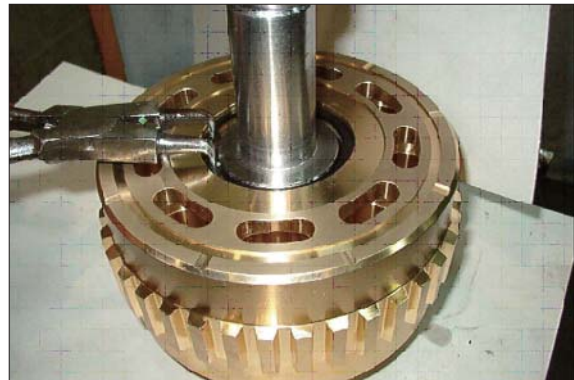

21078TM36



21078TM37

■ **Disassemble valve casing sub.**

- 12) Using an hexagon wrench, unloosing wrench bolt (45) and disassemble cover (37), spring (38), spool (39), spring seat (43), spring (36) and spring seat (35), respectively.
(Same balance on both sides)

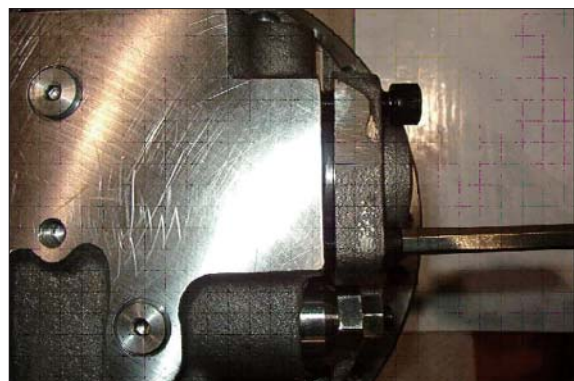

21078TM38



21078TM39

13) Disassemble spool (59), spool (47), O-ring (51), guide (48) and snap ring (53) on rear cover, respectively.

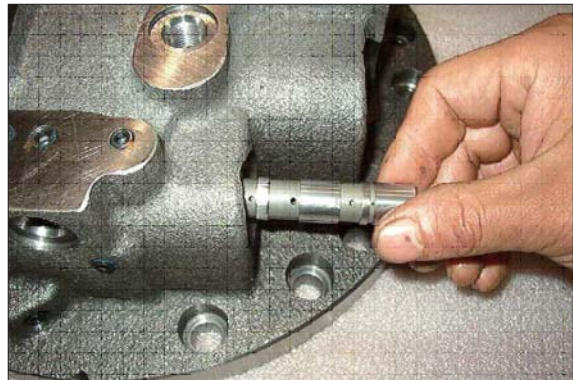

21078TM40



21078TM41

14) Using a torque wrench, disassemble relief assembly (46) on rear cover.

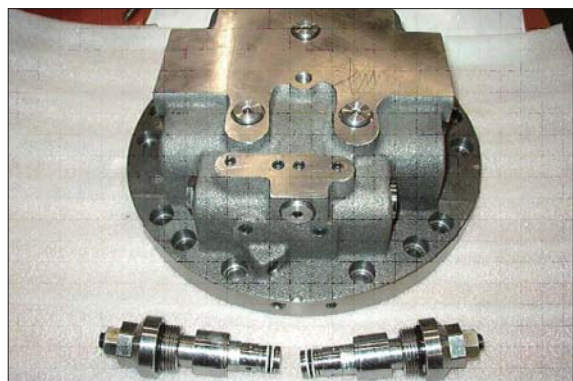

21078TM42

4. OUTLINE FOR ASSEMBLING

1) GENERAL SUGGESTIONS

- (1) After washing each parts cleanly, dry it with compressed air.
Provided that you do not wash friction plate with treated oil.
- (2) In bonding each part, fasten bond torque.
- (3) When using a hammer, do not forget to use a plastic hammer.

4.1 ASSEMBLING

■ Assemble the sub of turning axis

- 1) Using a jig, assemble oil seal (3) into shaft casing (1)



21078TM43

- 2) Have a bearing (8) thermal reacted into shaft (6).



21078TM44



21078TM45



21078TM46

- 3) Using a jig, assemble shaft assembly into shaft casing (1).



21078TM47

- 4) After spreading grease on steel ball (8) assemble into shaft casing (1).



21078TM48

- 5) Assemble swash piston assembly (4, 5) into shaft casing (1).



21078TM49

- 6) Assemble swash plate (9) into shaft casing (1).



21078TM50

■ Assemble cylinder block sub.

- 7) Assemble spring seat (13), spring (12), spring seat (11) into cylinder block (10) respectively, pushing spring (12) using by a jig, assemble snap ring (14) with a snap ring (14).



21078TM51

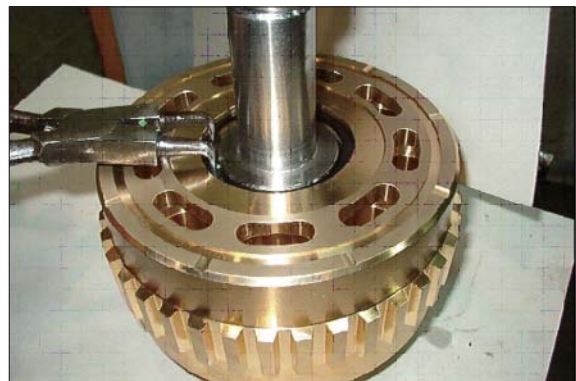

21078TM52

8) Assemble ring, pin (15) on cylinder block (10) ball guide (16) respectively.



21078TM53



21078TM54



21078TM55

9) Assemble cylinder block assembly, piston assembly (9), seat plate (17).



21078TM56

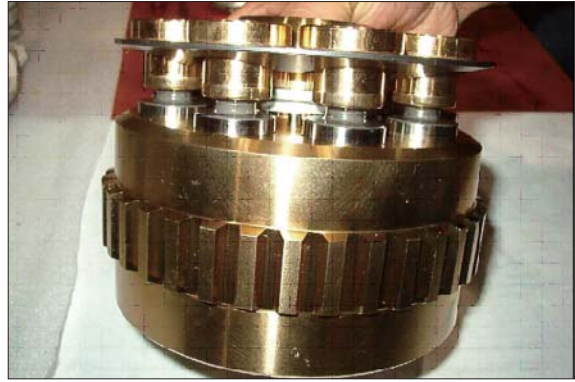

21078TM57

10) Assemble cylinder block assembly (9) into shaft casing (1).

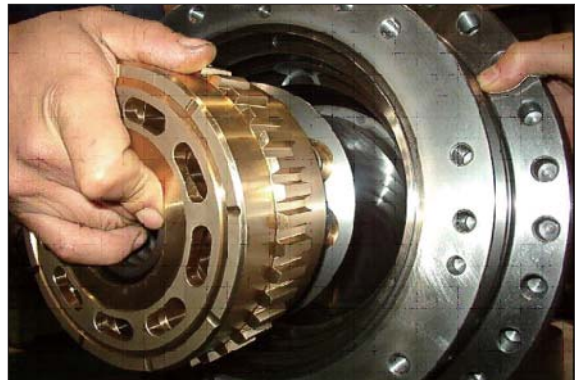

21078TM58

11) Assemble friction plate (19) and plate (20) into shaft casing (1) respectively, prepare 6 set.



21078TM59

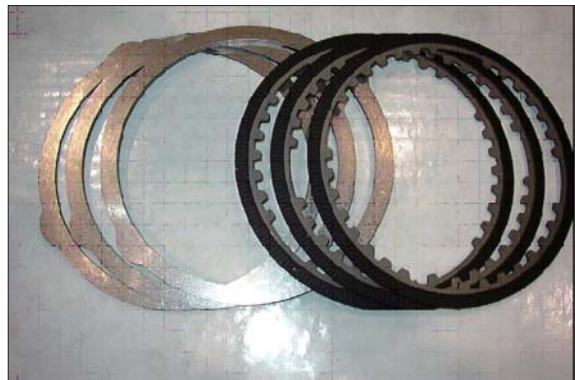

21078TM59-1

12) Assemble O-ring (22, 23) into packing piston (21).



21078TM60

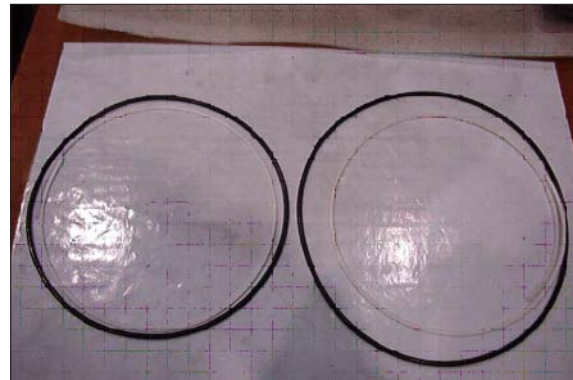

21078TM60-1

13) After spreading grease on packing piston (21) bond wrench bolt and assemble shaft casing (1).



21078TM61

■ Assemble rear cover sub.

14) Using a jig, assemble bearing (69) into rear cover (29).



21078TM62

- 15) After assembling spool (59), spool (47), O-ring (51), guide (48) and snap ring (53) respectively into rear cover (29).
Using torque wrench, assemble it.



21078TM63

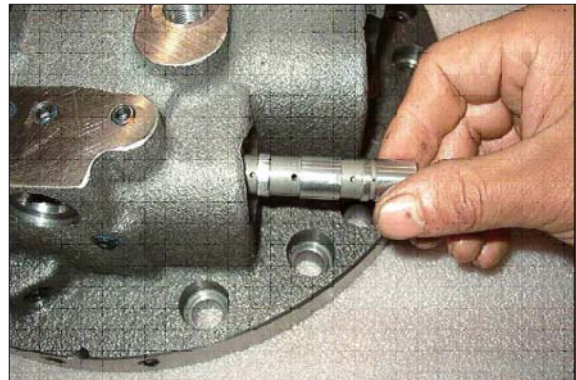

21078TM64

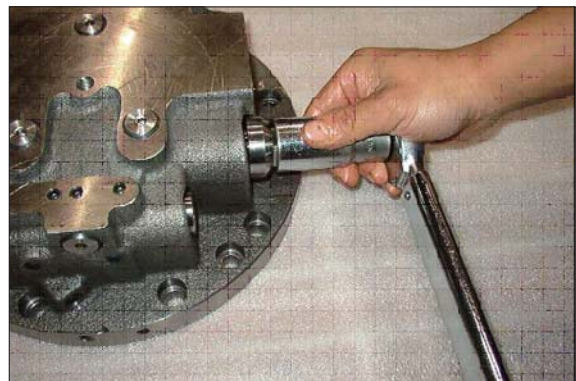

21078TM65

16) Assemble spring seat (35), spring (36), spring seat (43), spool (39), spring (38), cover (37) respectively and assemble wrench bolt (45).
(Same balance on both sides)

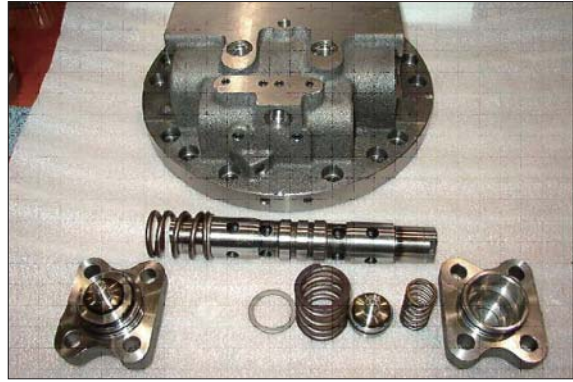

21078TM66

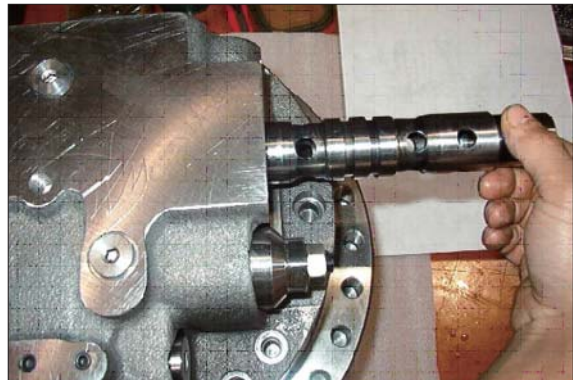

21078TM67

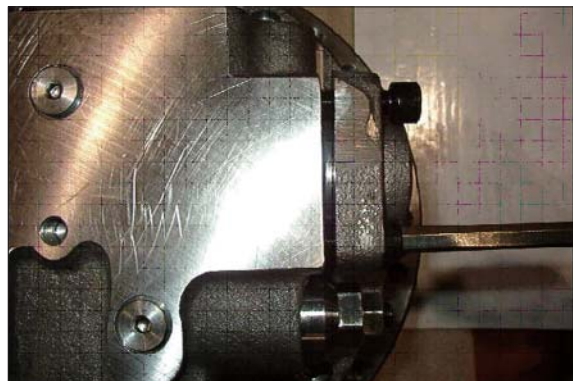

21078TM67-1

17) Assemble plug (2).

※ Plug (NPT1/16) - 11EA



21078TM68



21078TM69

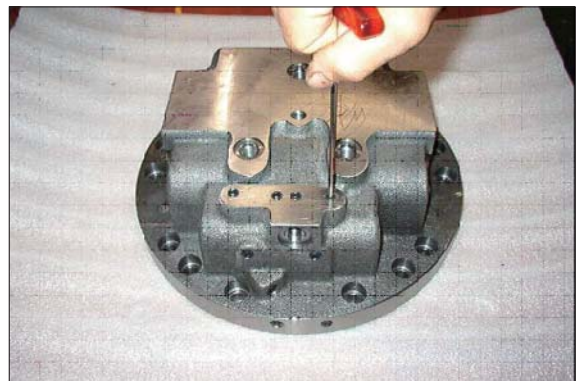

21078TM70



21078TM71

18) Assemble plug (64).

※ Plug (PT3/8) - 11EA

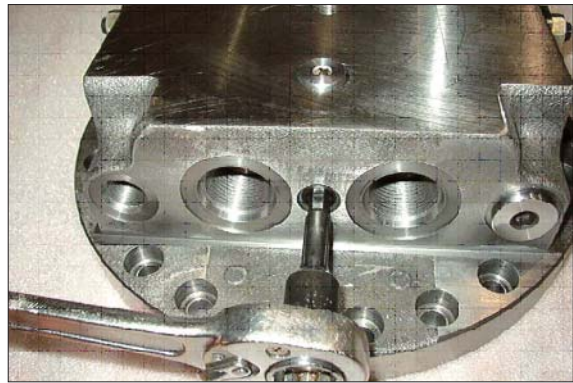

21078TM72

19) Assemble plug (62, 63) into rear cover (29) and assemble relief valve assembly.

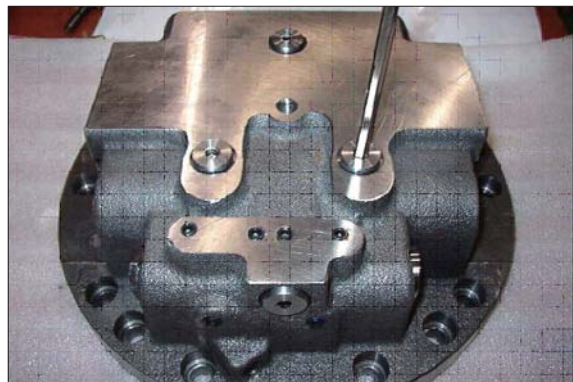

21078TM73

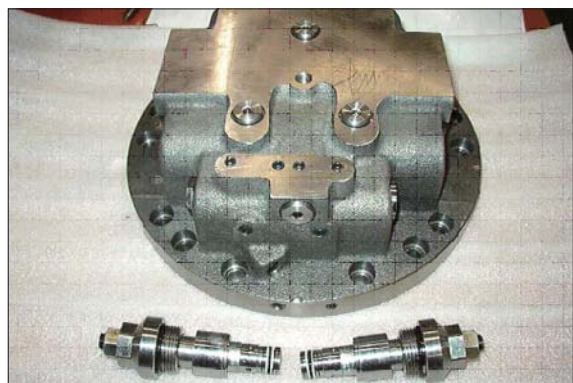

21078TM74

20) Put spring (67, 68) together into rear cover (29), prepare 6 set.



21078TM75



21078TM76

21) Assemble valve plate (70) into rear cover (29).



21078TM77

22) After assembling shaft casing (1) and rear cover (29).
Assemble spool assembly (30), spring (38),
spool (39), cover (37) after then complete
assembly with wrench bolt (45).

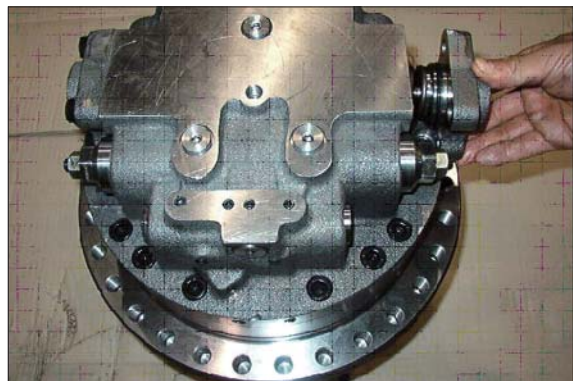

21078TM78

23) Finish assembly.



21078TM79

5.1 DISASSEMBLING REDUCTION UNIT

1) Preparation for disassembling

- (1) The reduction units removed from excavator are usually covered with mud. Wash outside of propelling unit and dry it.
- (2) Locate reducer in order for drain port to be at the lowest level loosen taper screw plug of drain port, and drain oil from reduction gear.
 - ※ While oil is still hot, inside of the unit may be pressurized.

▲ Take care of the hot oil gushing out of the unit when loosening the plug.

(3) Mark for mating

Put marks on each mating parts when disassembling so as to reassemble correctly as before.

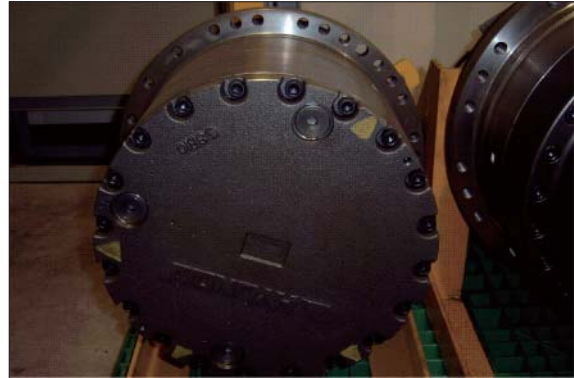

21078TM80

2) Setting reduction unit (or whole propelling unit) on work stand for disassembling

- (1) Remove M12 hexagon socket head bolts (95) at 3 places from cover (93) almost equally apart each other, and then install M12 × 155L eye bolts. Lift up the unit using them and place it on work stand with cover upward.

▲ Take great care not to pinch your hand between parts while disassembling nor let fall parts on your foot while lifting them.



21078TM81

3) Removing cover

- (1) Remove the rest of M12 hexagon socket head bolts (95) that securing gear and housing. Loosen all the socket bolts and then, disassemble cover.
- (2) As the cover (93) is adhered to ring gear (88), disassemble ring gear (88) and cover (93) by lightly hammering slantwise upward using sharpened punch inserted between the cover and ring gear.

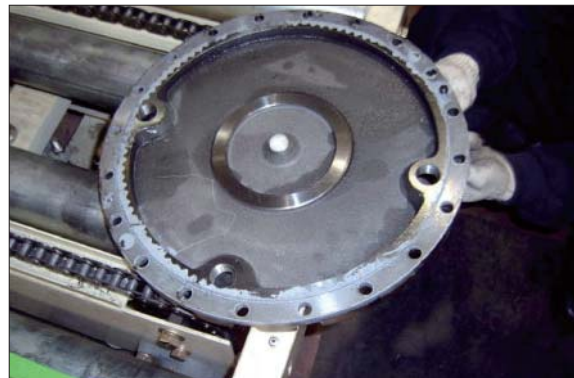

21078TM82

4) Removing No.1 carrier sub assembly

- (1) Screw three M10 eye-bolt in No.1 carrier and lift up and remove No.1 carrier assy.



21078TM83

- (2) Remove No.1 sun gear

- ※ Be sure to maintain it vertical with the ground when disassembling No.1 sun gear.



21078TM84

5) Removing No.2 carrier sub assembly

- (1) Screw three M10 eye-bolt in No.2 carrier and lift up and remove No.2 carrier assy.



21078TM85

- (2) Remove No.2 sun gear

- ※ Be sure to maintain it vertical with the ground when disassembling No.2 sun gear.

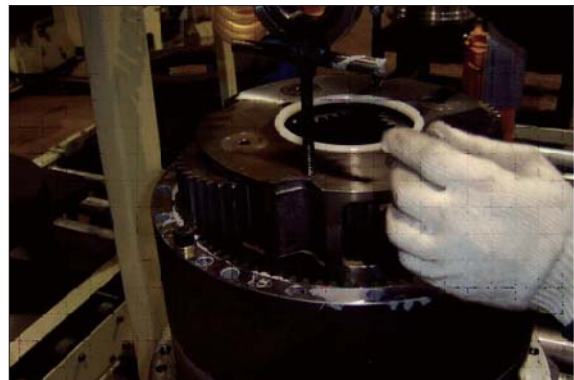

21078TM86

6) Removing ring gear

- (1) As the ring gear (88) is adhered to housing (81), disassemble ring gear (88) and housing (81) by lightly hammering slantwise upward using sharpen punch inserted between the ring gear and housing.
 - ※ Carefully disassembling ring gear not to make scratch on it.
- (2) Screw M14 eye-bolt in ring gear and lift up and remove it.

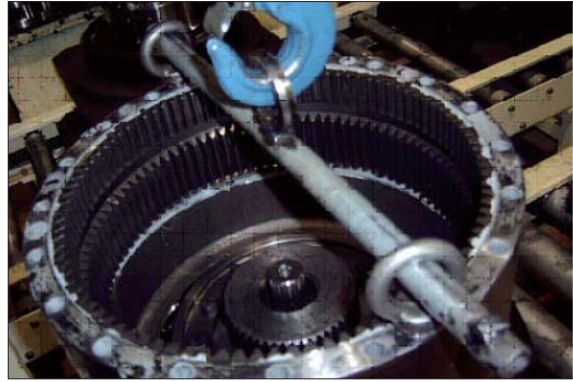

21078TM87

7) Removing coupling

- (1) Remove coupling.



21078TM88

8) Removing retainer & shim

- (1) Remove M12 hexagon socket head bolts that secure retainer and motor.
- (2) Remove retainer & shim.

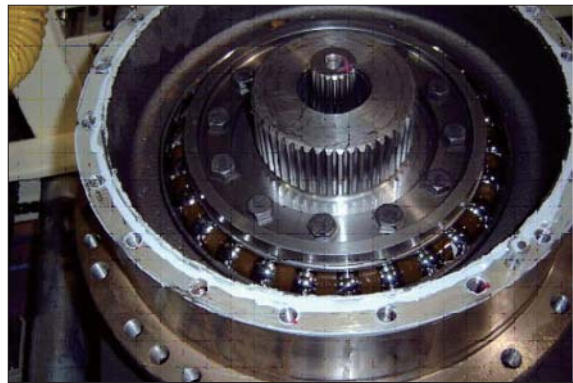

21078TM89

9) Removing housing sub assembly

- (1) Screw M12 eye bolt in housing and lift up housing assembly including angular bearing and floating seal.



21078TM90

10) Removing floating seal

- (1) Lift up a piece of floating seal of motor side.



21078TM91

11) Disassembling housing assembly

- (1) After turning housing, lift up a piece of floating seal from housing and then remove it.
- ※ Don't disassemble angular bearing.

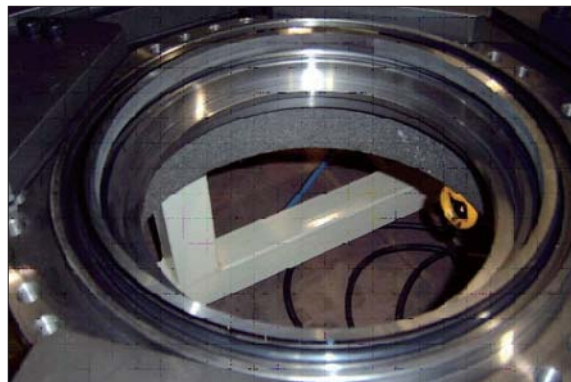

21078TM92

12) Disassembling No.1 carrier

- (1) Remove thrust ring (90-7) from carrier.
- (2) Knock spring pin (91-8) fully into No.1 pin (91-7).
- (3) Remove planetary, thrust washer, No.1 pin, bearing from carrier.



21078TM93



21078TM94



21078TM95

13) Disassembling No.2 carrier

- (1) Disassemble No.2 carriers, using the same method for No.1 carrier assembly.



21078TM96



21078TM97

6.1 ASSEMBLY REDUCTION GEAR

■ General notes

Clean every part by kerosene and dry them by air blow.

Surfaces to be applied by locktite must be decreased by solvent.

Check every part for any abnormalities.

Each hexagon socket head bolt should be used with locktite No.

262 applied on its threads.

Apply gear oil slightly on each part before assembling.

Take great care not to pinch your hand between parts or tools while assembling nor let fall parts on your foot while lifting them.

Inspection before reassembling

Thrust washer

- Check if there are seizure, abnormal wear or uneven wear.
- Check if wear is over the allowable limit.

Gears

- Check if there are pitting or seizure on the tooth surface.
- Check if there are cracks on the root of tooth by die check.

Bearings

- Rotate by hand to see if there are something unusual such as noise or uneven rotation.

Floating seal

- Check flaw or score on sliding surfaces or O-ring.



21078TM98

1) Assembling No.1 carrier

- (1) Put No.1 carrier (91-1) on a flat place.
- (2) Install No.1 needle bearing (91-5) into No.1 planetary gear (91-4), put 2EA of No.1 thrust washer (91-6) on both sides of bearing, and then, install it into carrier.



21078TM99

- (3) Install No.1 pin (91-5) into No.1 carrier where the holes for No.1 pin (91-5) are to be in line with those of No.1 carrier, and then, install spring pins into the holes.



21078TM100

- (4) Caulk carrier holes as shown on the picture.
 (5) Assemble thrust ring (90-7) into carrier.



21078TM101

2) Assembling No.2 carrier

- (1) Put No.2 carrier (90-1) on a flat place.
 (2) Install No.2 needle bearing (90-3) into No.2 planetary gear (90-2), put 2EA of No.2 thrust washer (90-4) on both sides of bearing, and then, install it into carrier.

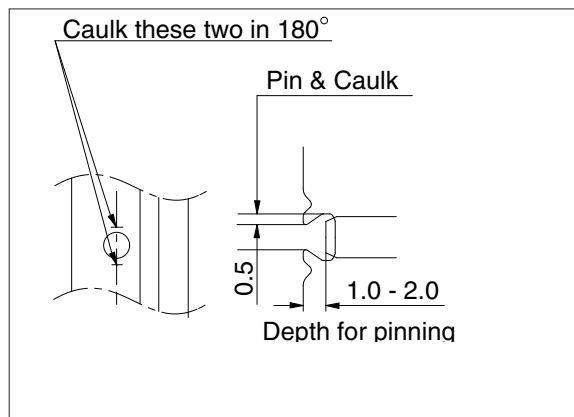

21078TM102

- (3) Install No.2 pin (90-5) into No.2 carrier where the holes for No.2 pin (90-5) are to be in line with those of No.2 carrier, and then, install spring pins into the holes.



21078TM103

- (4) Caulk carrier holes as shown on the picture.
- (5) Assemble thrust ring (90-7) into carrier.

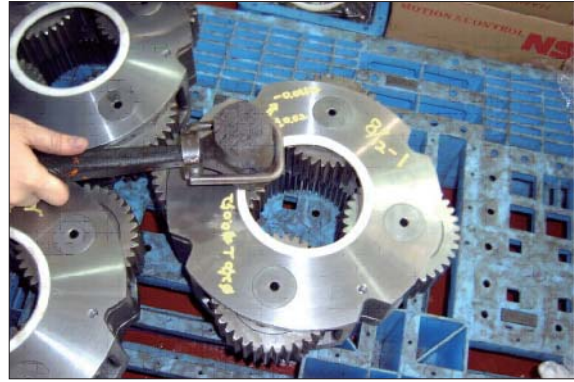

21078TM104

3) Assembling floating seal (83) and main bearing (82)

- (1) Assemble floating seal into motor by use of pressing jig. Grease the contact parts for floating seal which is assembled into motor.
- (2) Heat bearing at 60~70°C and then, put into the motor side.



21078TM105

- ※ Be sure to maintain it vertical with the ground when assembling bearing and floating seal.



21078TM106

4) Assembling housing

- (1) Heat housing at 60~70°C while clearing it out and then, assemble floating seal into housing by use of pressing jig.
- ※ Be sure to maintain it vertical with the ground when assembling floating seal.



21078TM705

5) Installing housing assembly

- (1) Install 2EA of M12 eye-bolt into housing assembly.
 - (2) Assemble housing into motor by use of hoist and eye-bolt.
- ※ Be sure to tighten eye-bolt deep enough.



21078TM108

6) Installing main bearing (82)

- (1) Heat main bearing at 60~70° C and then, install.
- ※ Be sure to maintain it vertical with the ground when assembling bearing.



21078TM109

7) Installing retainer (85) and shim (84)

- (1) Measure clearance between main bearing and retainer by use of jig to decide the thickness of shim and select an appropriate shim, and then, assemble retainer.
- (2) Apply locktite (#262) on M12 hexagon head bolt, and then, bolt.

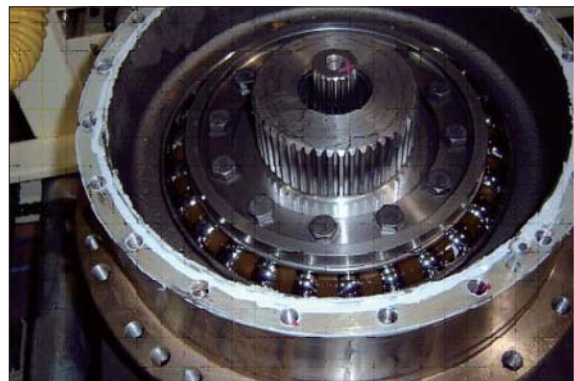

21078TM110

8) Installing coupling

- (1) Install coupling on spline of the motor.

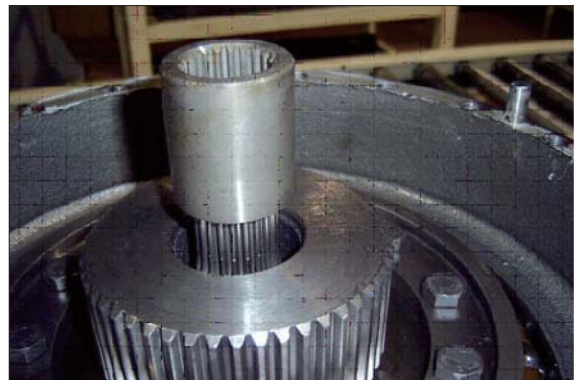

21078TM111

9) Installing ring gear

- (1) Apply three bone #1104 (loctite #515) on housing for ring gear without gap.
- (2) Insert lock pin into housing hole.
- (3) Install M14 eye-bolt on the tap of ring gear.
- (4) Lift ring gear and then, assemble into housing in order for hole of ring gear and parallel pin of housing to be in line.
- (5) Temporarily secure 4EA of M12 hexagon socket bolt and shim with cover thickness having appropriate torque.

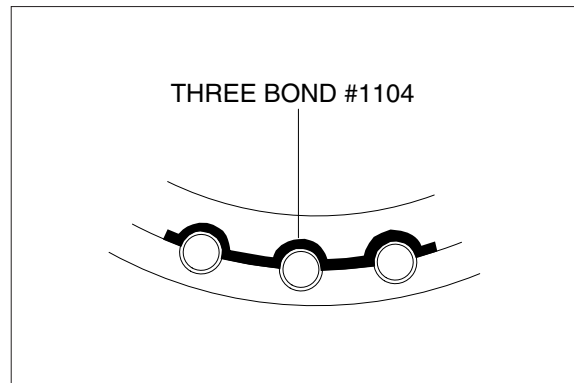

21078TM112A

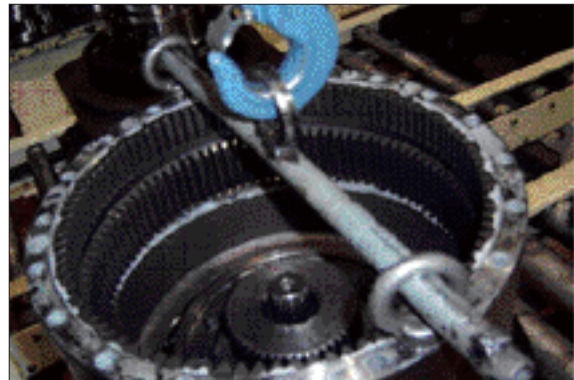

21078TM113

10) Installing No.2 carrier sub assembly

- (1) Install M10 eye-bolt on No.2 carrier assembly.
- (2) Lift No.2 carrier assembly and then, slowly put it down on ring gear.
- (3) Rotate planetary gear by hands and install on ring gear.



21078TM114

11) Installing No.2 sun gear (91-2)

- (1) Install No.2 sun gear on the spline of No.2 carrier and No.2 planetary gear, matching teeth of them.



21078TM115

- (2) Install No.2 sun gear on the spline of No.2 carrier and No.2 planetary gear, matching teeth of them.

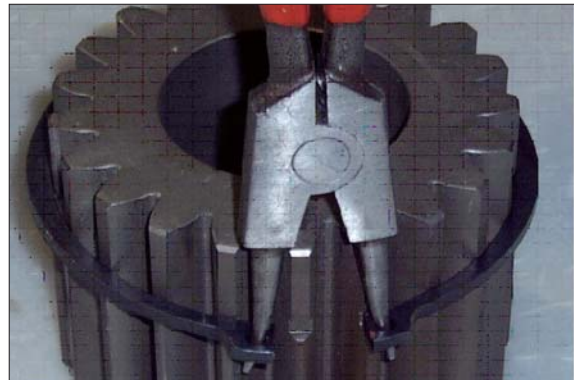

21078TM116

12) Installing No.1 carrier sub assembly

- (1) Install M10 eye-bolt on No.2 carrier assembly.
- (2) Lift No.1 carrier assembly and then, slowly put it down on ring gear.
- (3) Rotate planetary gear by hands and install on ring gear.



21078TM117

13) Installing No.1 sun gear (92)

- (1) Put down No.1 sun gear on No.1 carrier, maintaining it vertical with spline of coupling.
- (2) Install No.1 sun gear on No.1 planetary gear, matching their teeth.



21078TM118

14) Installing cover (93)

- (1) Beat pad (94) with plastic hammer, and press it into the center of cover.
- (2) Apply three bond #1104 (loctite #515) on the ring gear for cover without gap.
- (3) Put cover on ring gear, apply loctite (#262) on M12 hexagon socket head bolt, and then, bolt.

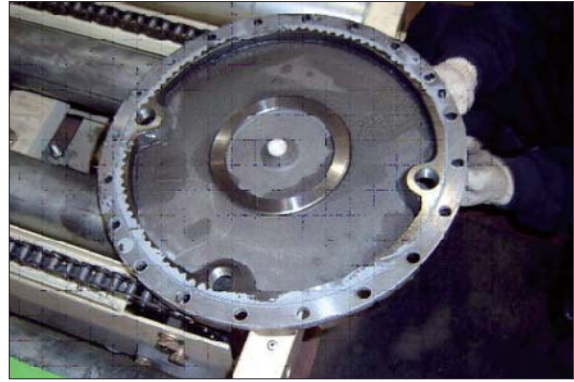

21078TM119

- (4) Fill gear oil (5.8liter) into drain port.
- (5) Apply gear oil on PF3/4 hydraulic plug (97) and then, bolt.



21078TM120

GROUP 6 TRAVEL DEVICE (TYPE 2)

1. REMOVAL AND INSTALL

1) REMOVAL

- (1) Swing the work equipment 90° and lower it completely to the ground.
- (2) Operate the control levers and pedals several times to release the remaining pressure in the hydraulic piping.
- (3) Loosen the breather slowly to release the pressure inside the hydraulic tank.

▲ Escaping fluid under pressure can penetrate the skin causing serious injury.

※ When pipes and hoses are disconnected, the oil inside the piping will flow out, so catch it in oil pan.

- (4) Remove the track shoe assembly.
For details, see **removal of track shoe assembly**.
- (5) Remove the cover.
- (6) Remove the hoses.
※ Fit blind plugs to the disconnected hoses.
- (7) Remove the bolts and the sprocket.
- (8) Sling travel device assembly (1).
- (9) Remove the mounting bolts (2), then remove the travel device assembly.
· Weight : 305 kg (670 lb)

2) INSTALL

- (1) Carry out installation in the reverse order to removal.
- (2) Bleed the air from the travel motor.
 - ① Remove the air vent plug.
 - ② Pour in hydraulic oil until it overflows from the port.
 - ③ Tighten plug lightly.
 - ④ Start the engine, run at low idling, and check oil come out from plug.
 - ⑤ Tighten plug fully.
- (3) Confirm the hydraulic oil level and check the hydraulic oil leak or not.

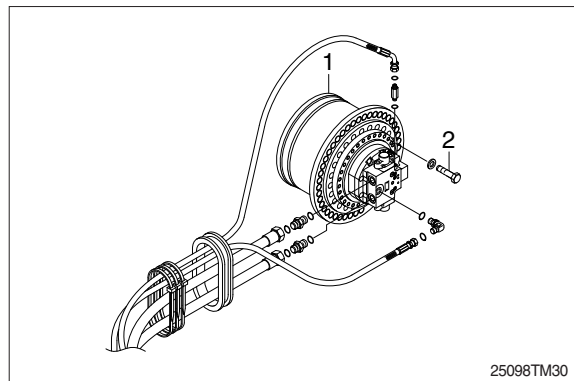

2. TRAVEL MOTOR

1) STRUCTURE

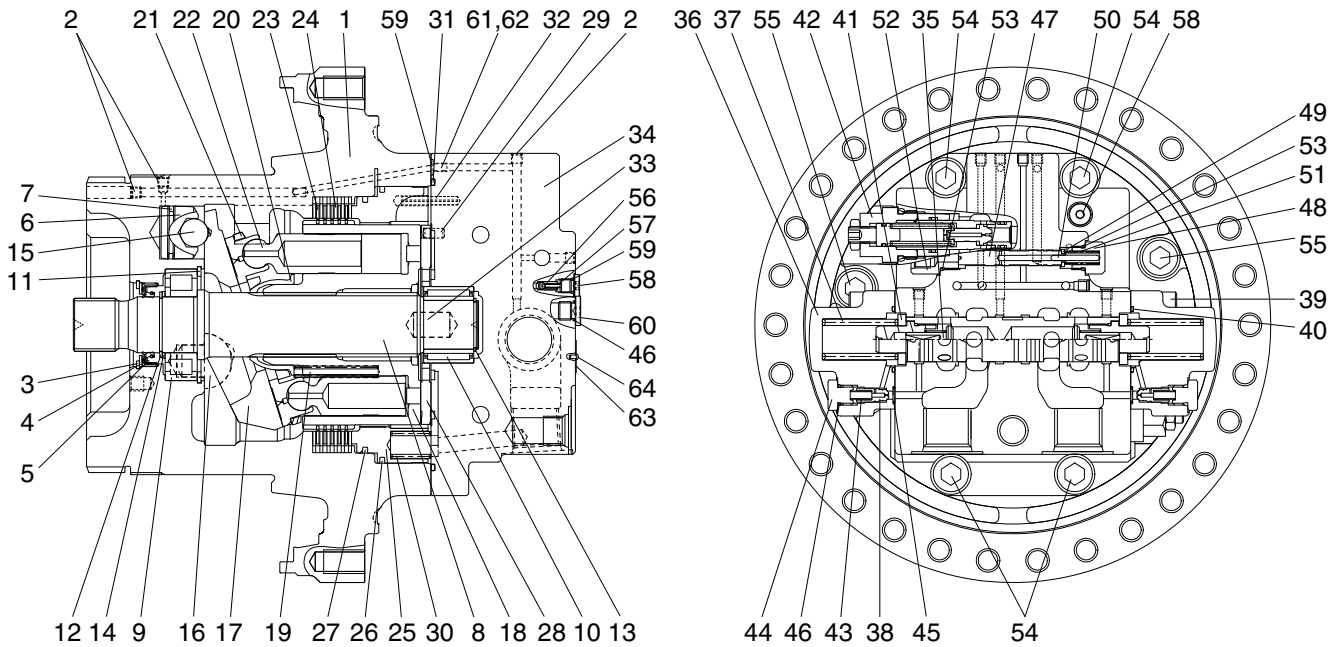

2209A2TM21

1	Casing	23	Friction plate	44	Plug
2	Plug	24	Separated plate	45	O-ring
3	Oil seal	25	Parking piston	46	O-ring
4	Thrust plate	26	D-ring	47	Spool
5	Snap ring	27	D-ring	48	Plug
6	Piston	28	Valve plate	49	Spring seat
7	Piston seal	29	Parallel pin	50	Parallel pin
8	Shaft	30	Spring	51	Spring
9	Cylinder roller bearing	31	O-ring	52	Connector
10	Needle bearing	32	Spring pin	53	O-ring
11	Snap ring	33	Parallel pin	54	Hexagon socket head bolt
12	Snap ring	34	Rear cover	55	Hexagon socket head bolt
13	Snap ring	35	Main spool assy	56	Check valve
14	Thrust plate	36	Cover	57	Spring
15	Steel ball	37	Spring	58	Plug
16	Pivot	38	Restrictor	59	O-ring
17	Swash plate	39	Hexagon socket head bolt	60	Plug
18	Cylinder block	40	O-ring	61	Restrictor
19	Spring	41	Spring seat	62	Restrictor
20	Ball guide	42	Relief valve assy	63	Name plate
21	Retainer plate	43	Spring	64	Rivet
22	Piston assy				

2) TOOLS AND TIGHTENING TORQUE

(1) Tools

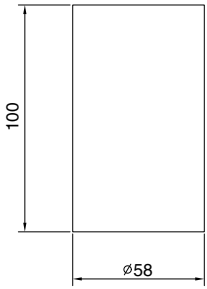
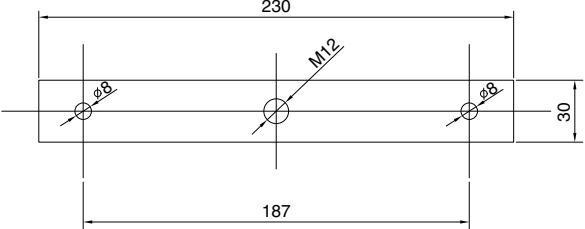
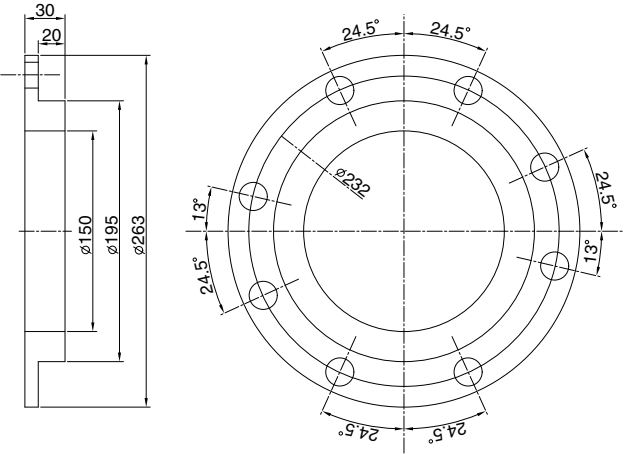
Tool name	Remark
Hexagon wrench	Width across flat 5, 6, 8, 10, 14 mm
Snap ring prier	For shaft $\varnothing 60\sim 80$ mm
Snap ring prier	For bore $\varnothing 32\sim 58$ mm
Plastic hammer	1 piece
Screw driver	Minus (-), medium size, 2 pieces
Torque wrench	10 kgf·m (72.3 lbf·ft), 33 kgf·m (238.6 lbf·ft), 45 kgf·m (325.4 lbf·ft)
Gig for inserting oil seal	 <p style="text-align: right;">25098TM31</p>
Gig for inserting parking piston (M10×100 bolt 2EA, M12×100 bolt 1EA)	 <p style="text-align: right;">25098TM32</p>
Gig for pulling out brake piston	 <p style="text-align: right;">25098TM33</p>

(2) Tightening torque

Item	Name	Size	Torque	
			kgf · m	lbf · ft
2	Plug	NPTF 1/16	1.1±0.1	7.9±0.72
39	Hexagon socket head bolt	M12	1.0±1.0	72.3±7.2
42	Relief valve	1 5/16	34±3.4	246±24.6
44	Plug	PF 1/4	2.8±0.3	20.3±2.17
48	Plug	PF 3/8	5.5±0.5	39.8±3.6
52	Connector	PF 3/8	5.5±0.5	39.8±3.6
54	Hexagon socket head bolt	M18	38±3.8	275±27.5
55	Hexagon socket head bolt	M18	38±3.8	275±27.5
58	Plug	PF 1/8	1.5±0.1	10.8±0.72
60	Plug	PF 1/4	3±0.3	21.7±2.17

3. DISASSEMBLING

1) GENERAL INSTRUCTIONS

- ▲ Combustibles such as white kerosene are used for washing parts.**
These combustibles are easily ignited, and could result in fire or injury.
Be very careful when using.
 - ▲ Internal parts are coated with hydraulic fluid during disassembling and are slippery.**
If a part slips out of your hand and falls, it could result in bodily injury or could damage the park.
Be very careful when handling.
- (1) Generally, hydraulic equipment is precisely manufactured and clearances between each parts are very narrow. Therefore, disassembling and assembling works should be performed on the clean place where dusts hardly gather. Tools and kerosene to wash parts should also be clean and handled with great care.
 - (2) When motor is removed from the host machine, wash around the ports sufficiently and put the plugs so that no dust and/or water may invade. Take off these plugs just before the piping works when re-attach it to the host machine.
 - (3) Before disassembling, review the sectional drawing and prepare the required parts, depending on the purpose and the range of disassembling.
Seals, O-rings, etc., if once disassembled, are not reusable.
There are some parts that should be replaced as a subassembly.
Consult with the parts manual in advance.
 - (4) The piston can be inserted to whichever cylinder block for the initial assembling.
However, their combination should not be changed if they are once used. To reuse them, put the matching mark on both pistons and cylinder block before disassembling.
- ▲ Take great care not to pinch your hand between parts while disassembling nor let fall parts on your foot while lifting them.**

2) DISASSEMBLING TRAVEL MOTOR

- (1) Disassemble the wrench bolt (39) to tighten the spool cover (36) and rear cover (34) by using the L-wrench or impact wrench and then disassemble the spring (37), spring seat (41) and main spool assy (35) in order.

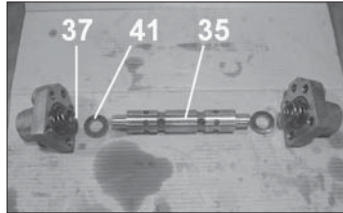

25098TM034

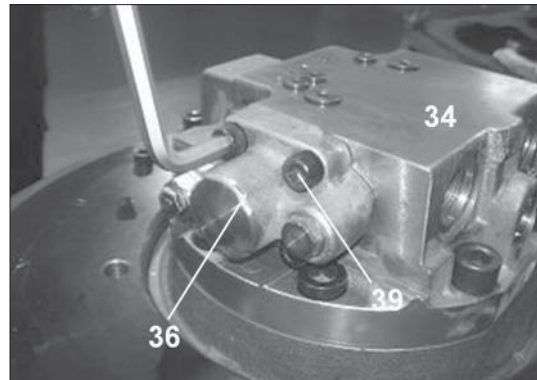

25098TM035

- (2) Disassemble the wrench bolt (54, 55) to tighten the casing (1) and rear cover (34) by using the L-wrench or impact wrench.

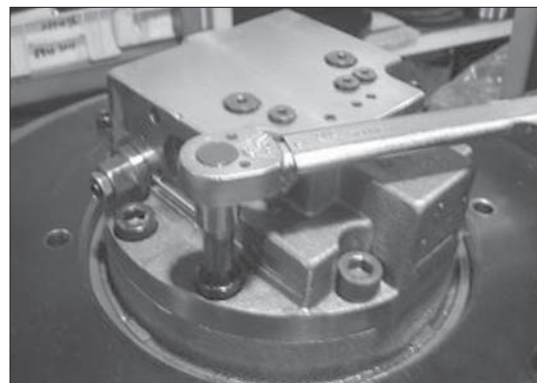

25098TM036

- (3) Separate the casing (1) and rear cover (34).

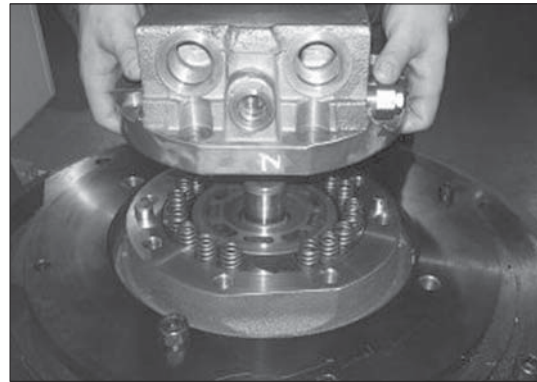

25098TM037

- (4) Disassemble the brake spring (30, 18EA) from the piston.

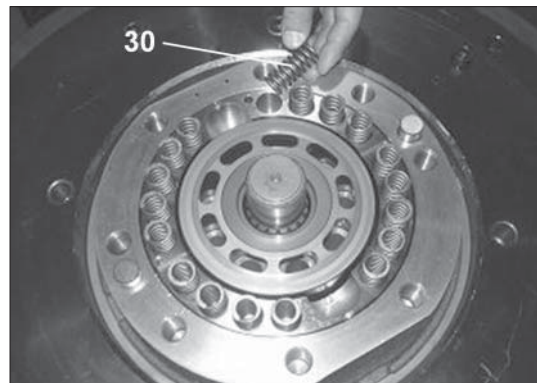

25098TM118

- (5) Disassemble the parking piston (25) by using the jig for disassembling parking piston.

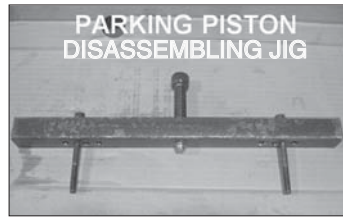

25098TM039

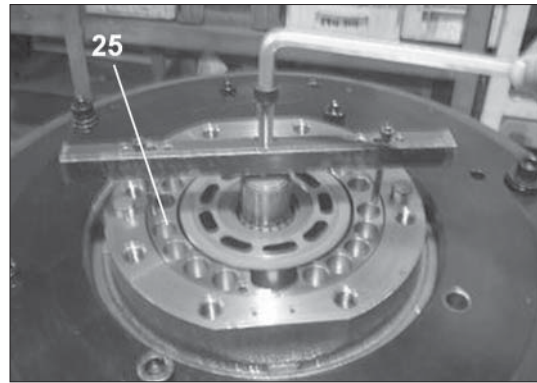

25098TM040

- (6) Disassemble the separated plate (24, 5EA) and friction plate (23, 4EA) from the casing.

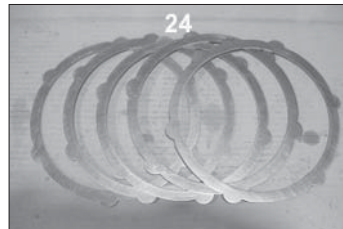

25098TM041

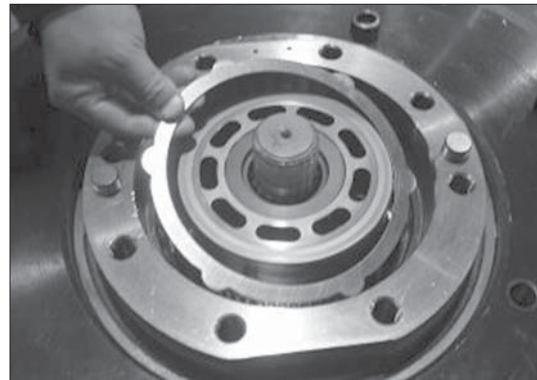

25098TM042

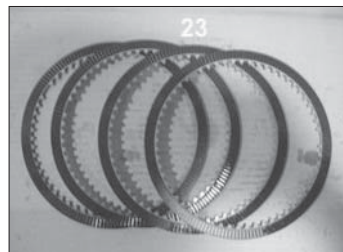

25098TM043

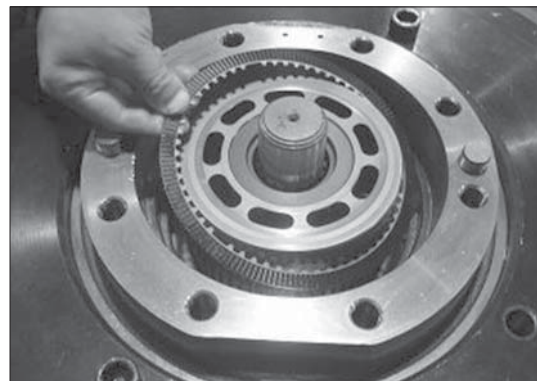

25098TM044

- (7) Turn the casing (1) horizontal by using the assemble truck and disassemble the cylinder block kit form the casing (1).

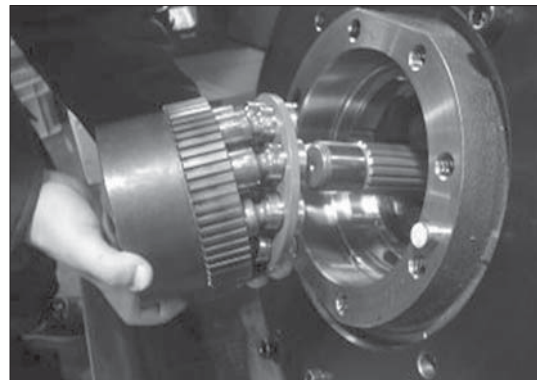

25098TM045

(8) Disassemble the cylinder block (18), retainer plate (21), piston assy (22), ball guide (20) and spring (19) from the cylinder block kit.

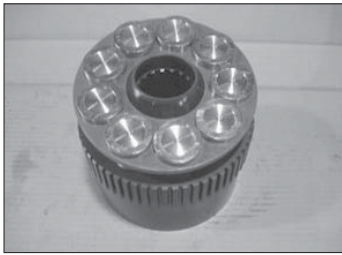

25098TM046

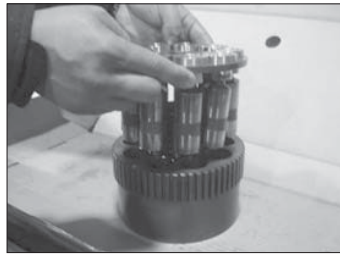

25098TM047

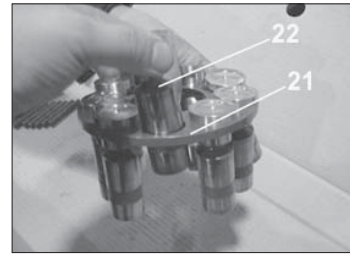

25098TM048

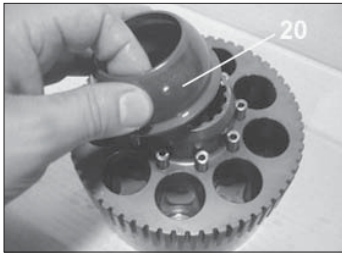

25098TM049

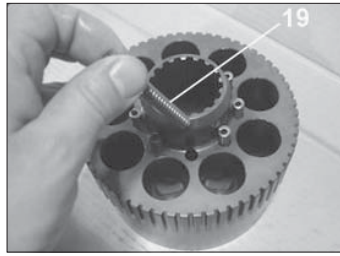

25098TM050

(9) Disassemble the swash plate (17) from the casing.



25098TM051

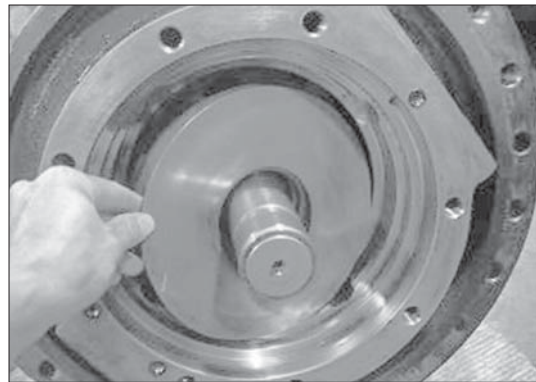

25098TM052

(10) Disassemble the steel ball (15) and swash piston (6) from the casing.

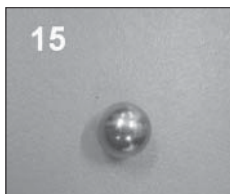

25098TM053

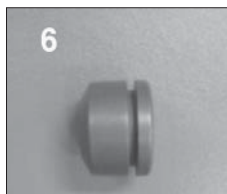

25098TM054



25098TM055

(11) Disassemble the pivot (16, 2EA) from the casing.

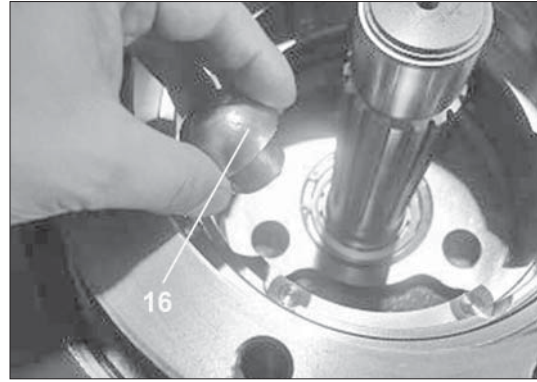

25098TM056

(12) Disassemble the snap ring (11) from the shaft (8) with the pryer for retaining ring.

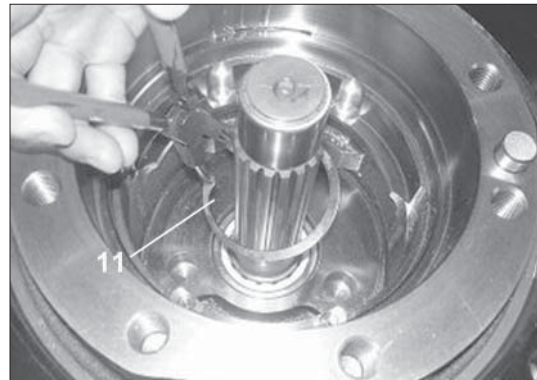

25098TM057

(13) Disassemble the shaft (8) from the casing (1).

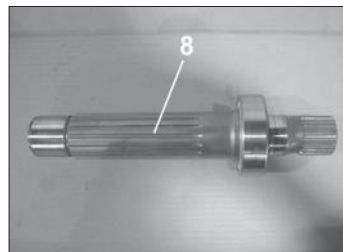

25098TM058

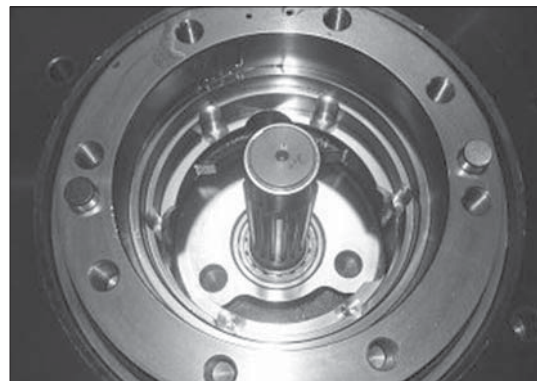

25098TM059

(14) Disassemble the snap ring (5) from the casing (1) with the pryer for retaining ring.

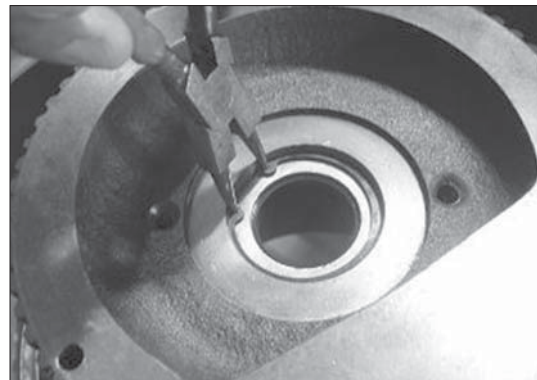

25098TM060

(15) Disassemble the thrust plate (4) from the casing (1).

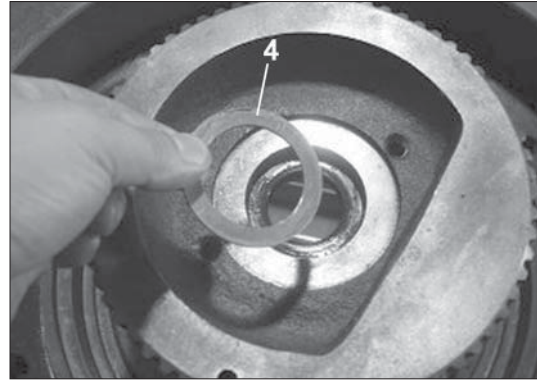

25098TM061

(16) Disassemble the oil seal (3) from the casing (1) with suitable tool.



25098TM062

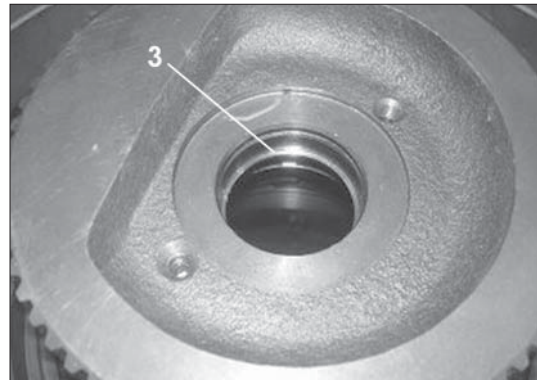

25098TM063

(17) Disassemble the O-ring (31) from the casing (1).

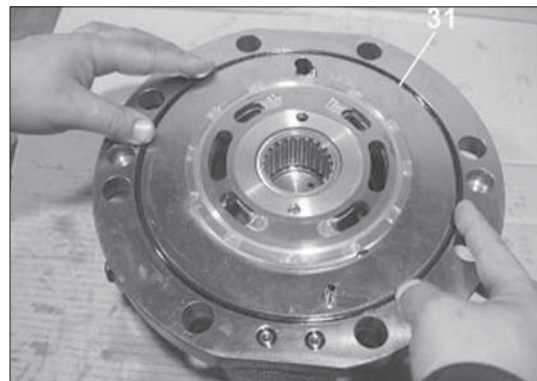

25098TM064

(18) Disassemble the valve plate (28) from the casing (1).

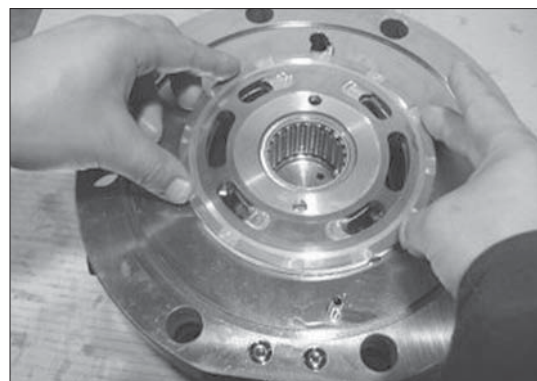

25098TM065

(19) Disassemble the relief valve (42, 2EA) from the rear cover (34) by using the torque wrench.

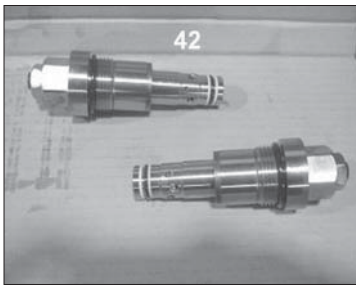

25098TM066

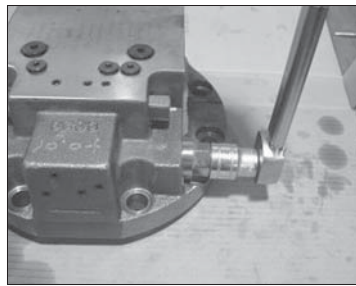

25098TM067

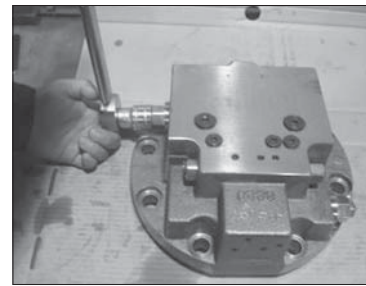

25098TM068

(20) Disassemble both side of the plug (48) and connector (52) from the rear cover (34) by using the torque wrench and then disassemble the spring (51), spring seat (49), parallel pin (50) and spool (47) in order.

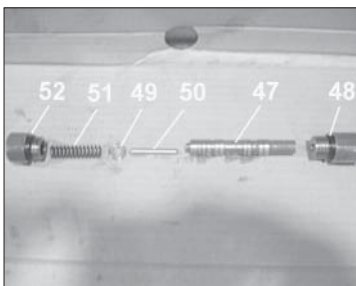

25098TM069

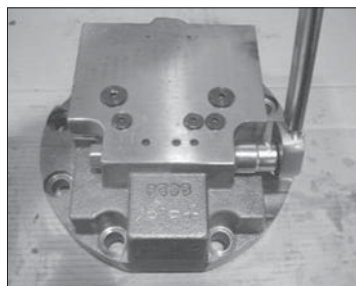

25098TM070

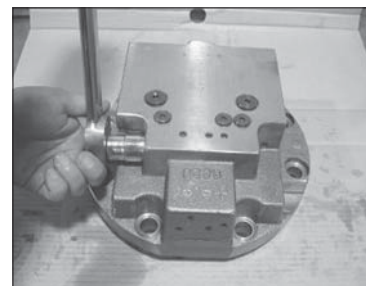

25098TM071

(21) Disassemble the plug (60) from the rear cover.

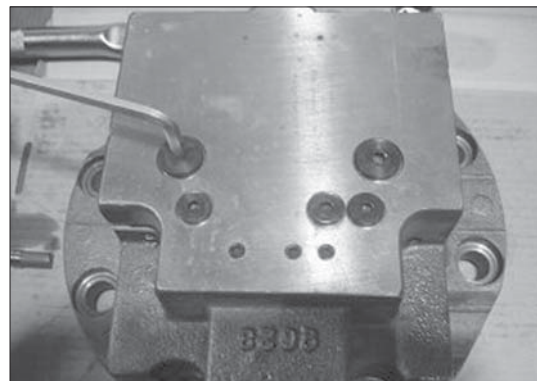

25098TM072

(22) Disassemble the plug (58) and then disassemble the spring (57) and check valve (56) from the rear cover in order.

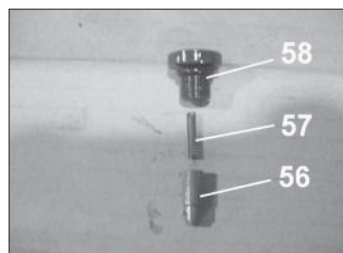

25098TM073

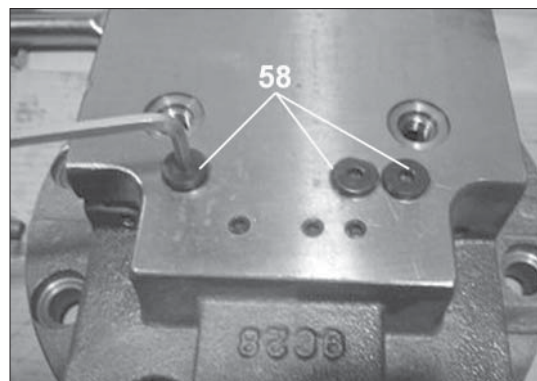

25098TM074

4. REASSEMBLING

1) ASSEMBLING MOTOR

- REAR COVER ASSY

- (1) Assemble the check valve (56) and the spring (57) to the rear cover and then tighten the plug (60) by using the L-wrench.

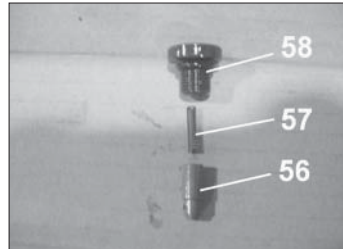

25098TM075

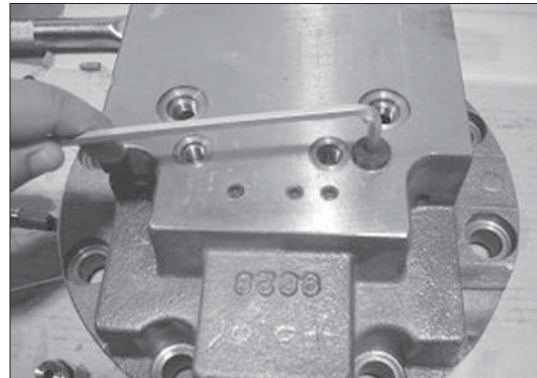

25098TM076

- (2) Apply the loctite #242 on the NPTF 1/16 plug (2, 12EA) and tighten it.

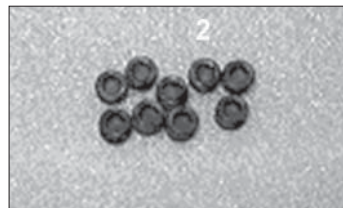

25098TM077

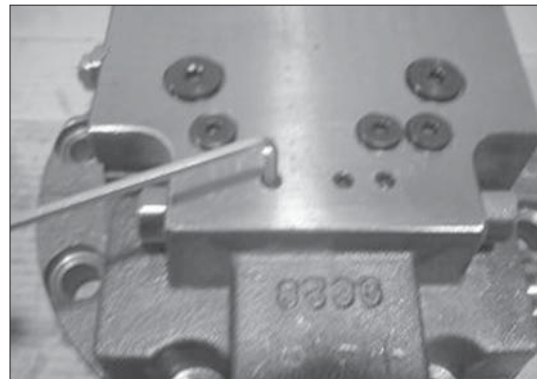

25098TM078

- (3) Assemble the spool (47), parallel pin (50), spring seat (49) and spring (51) into the rear cover (34) and tighten both side of the plug (48) and connector (52) into the rear cover (34).

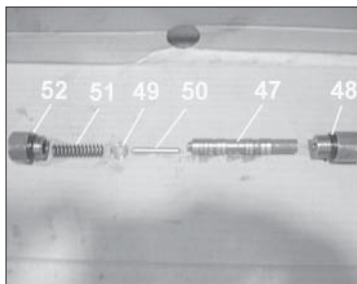

25098TM079

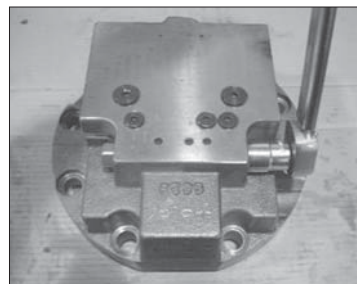

25098TM080

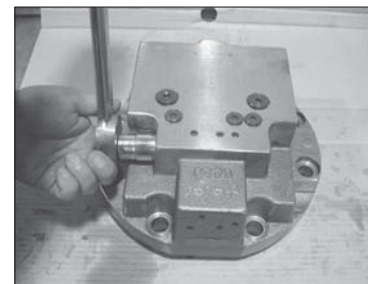

25098TM081

- (4) Assemble the relief valve (42, 2EA) into rear cover (34).

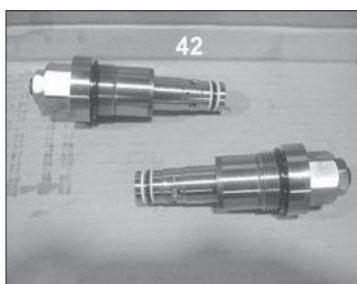

25098TM082

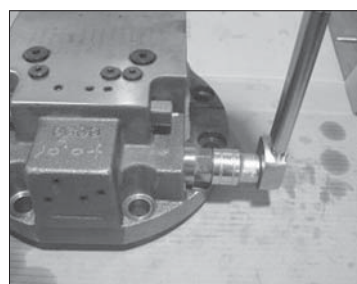

25098TM083

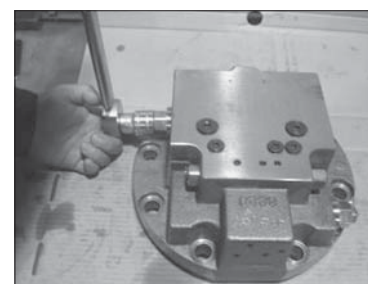

25098TM084

- (5) Tight fit the needle bearing (10) into rear cover (34) by using pressing jig.

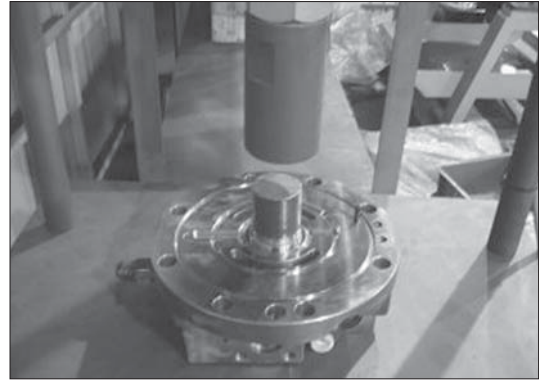

25098TM085

- (6) Assemble the spring pin (32) and parallel pin (29) into rear cover (34) by using round bar or small hammer.

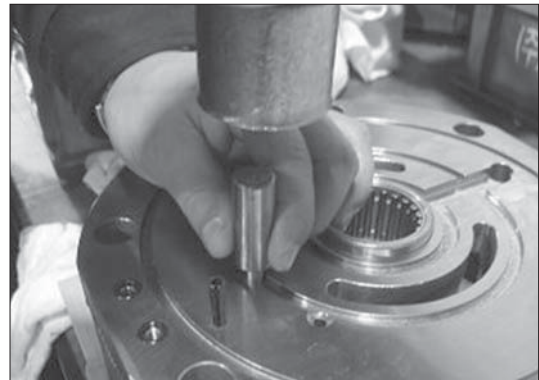

25098TM086

- (7) Assemble the valve plate (28) into rear cover (34).
Before assembling, apply some grease on contact surface of the valve plate.

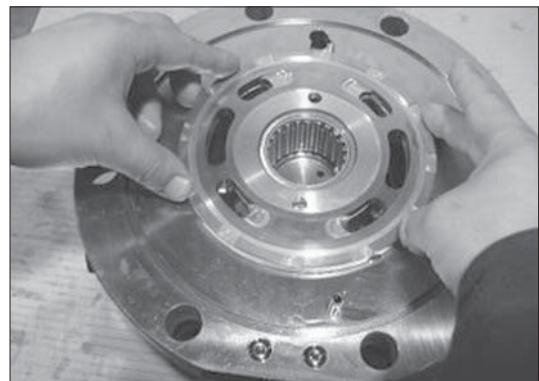

25098TM087

- (8) Apply some grease on the O-ring and fit it into groove.

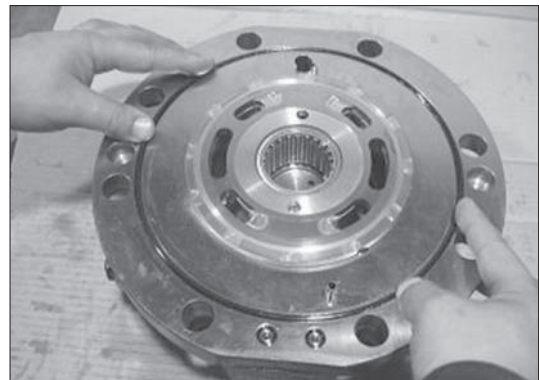

25098TM088

(9) Assemble the casing (1) on the assembling truck.

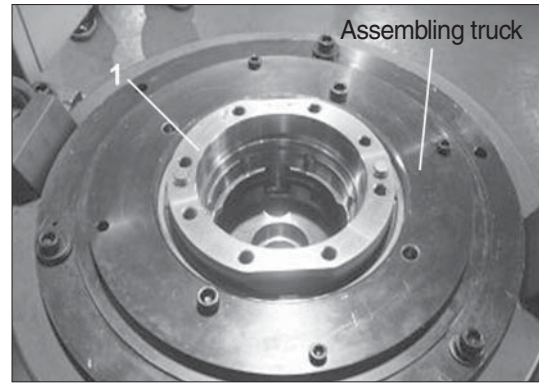

25098TM089

(10) Tight fit the oil seal (3) into the casing (1) by using jig.

※ Be careful direction of the oil seal.



25098TM090



25098TM091

(11) Assemble the thrust plate (4) into the casing (1).

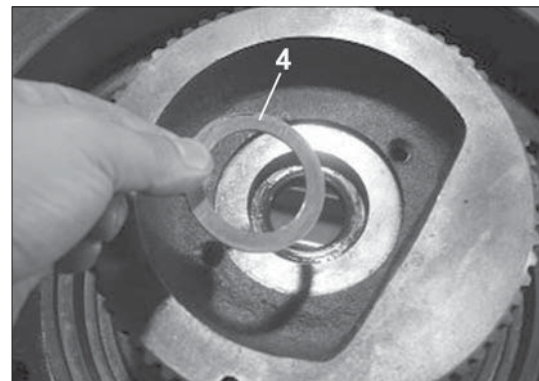

25098TM092

(12) Assemble the snap ring (5) into the casing (1) with the plier for retaining ring.

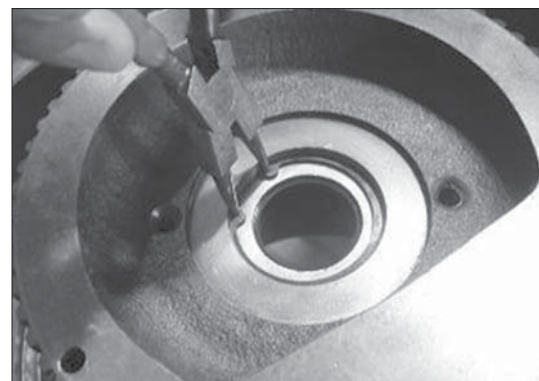

25098TM093

(13) Heat the roller bearing (9) and fit it into the shaft with shrink fitting.

- a. Shrink fitting can be used induction heating system and set the temperature at 100°C.
- b. Be careful not to damage the sliding surface of the oil seal of the shaft.



25098TM094



25098TM095

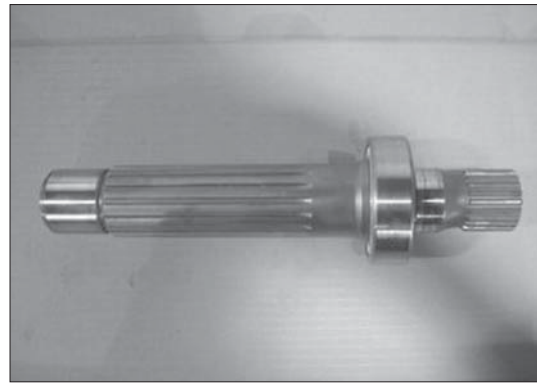

25098TM096

(14) Assemble the heat-fitted shaft (8) into casing (1).



25098TM097

(15) Assemble the snap ring (11) into the casing (1) with the plier for retaining ring.

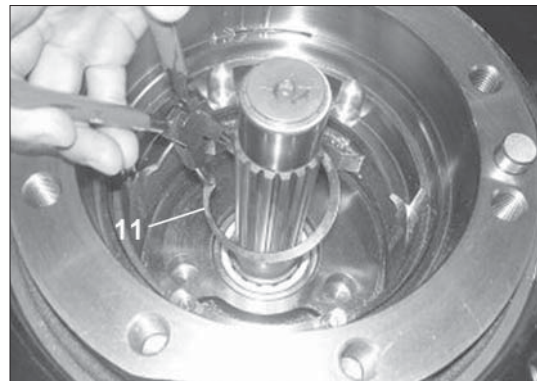

25098TM098

(16) Apply a little grease on the pivot (16, 2EA) and assemble it into the casing (1).

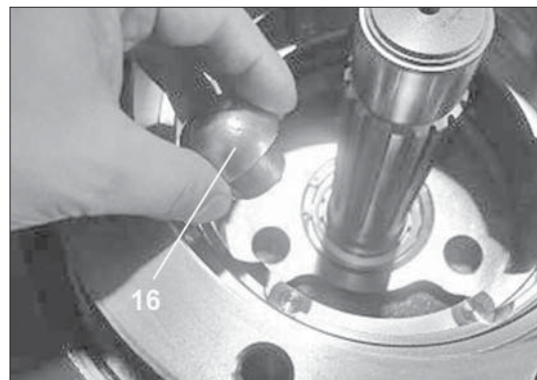

25098TM099

(17) Heat the piston seal (7) and fit it into the swash piston (6) and then tighten it a few minutes by band or tie. Loosen the band or tie and assemble it to the casing (1).

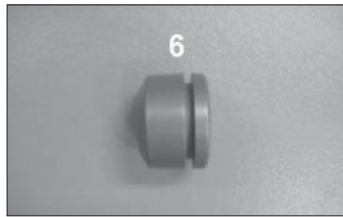

25098TM100

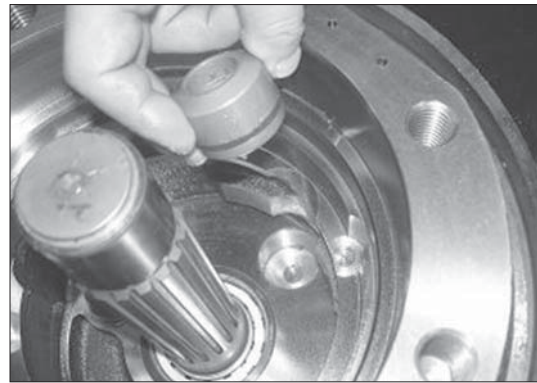

25098TM101

(18) Apply a little grease on the steel ball (15) and assemble it into the swash plate (17).

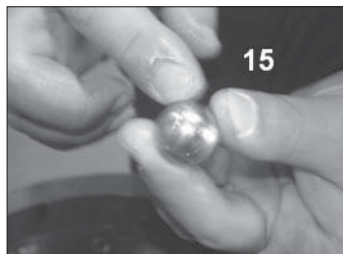

25098TM102



25098TM103

(19) Apply some grease on the steel ball hole of the swash plate (17) and assemble it casing (1).



25098TM104

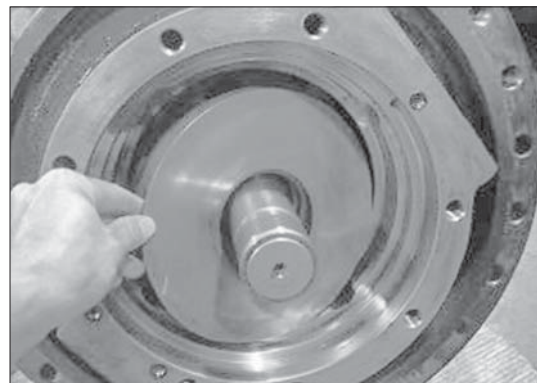

25098TM105

(20) Assemble the spring (19), ball guide (20), retainer plate (21) and piston assy (22) into cylinder block (18) in order.

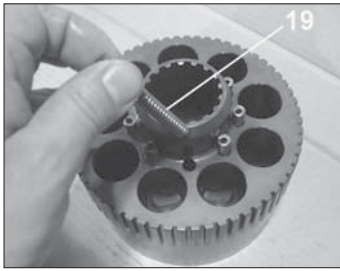

25098TM106

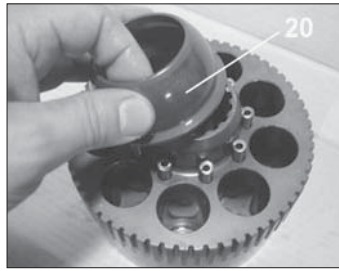

25098TM107

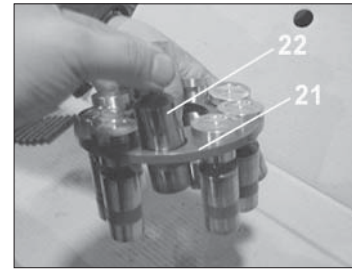

25098TM108

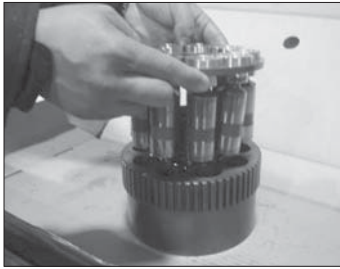

25098TM109



25098TM110

(21) Tilt the casing (1) sideways and assemble the cylinder block kit into the casing (1).

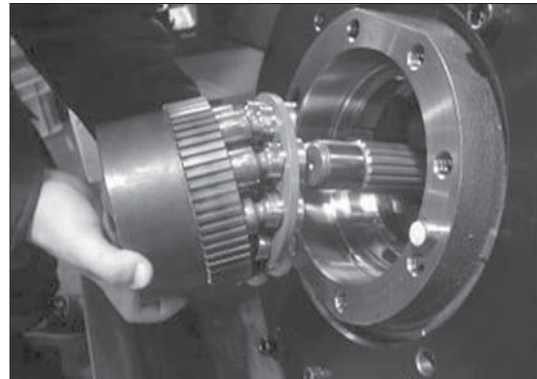

25098TM111

(22) Assemble the separated plate (24) and friction plate (23) into the cylinder block alternately.

Friction plate :

4EA

Separated plate :

5EA

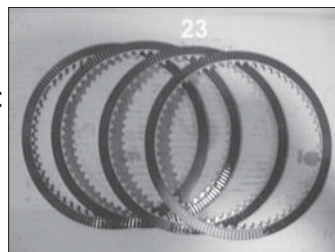

25098TM112

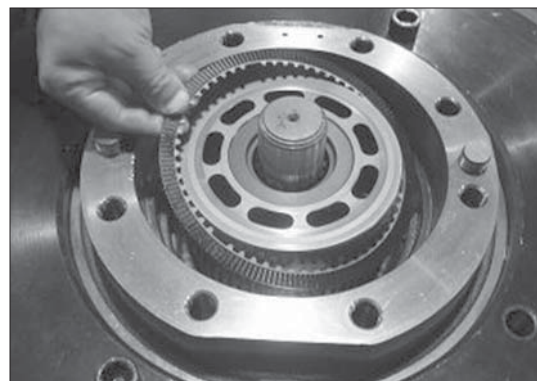

25098TM113

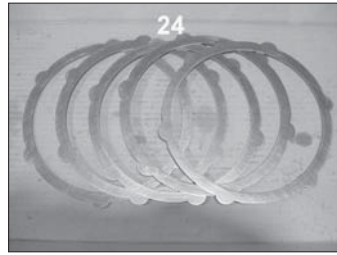

25098TM114

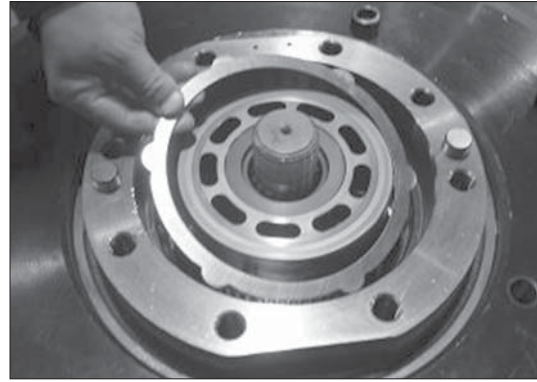

25098TM115

(23) Apply some grease on the D-ring and assemble it parking piston.

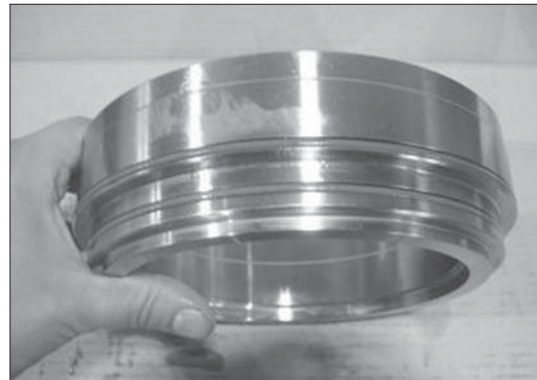

25098TM116

(24) Insert the parking piston into the casing and assemble it by using jig.

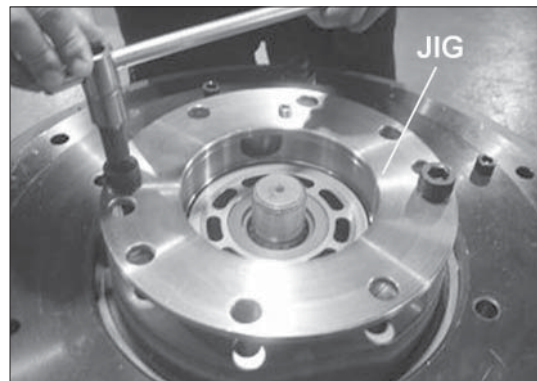

25098TM117

(25) Assemble the brake spring (30, 18EA) into the piston.

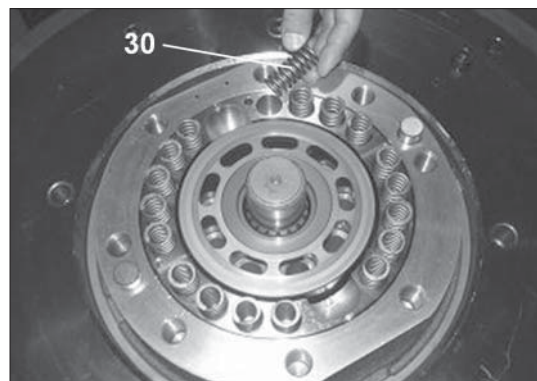

25098TM118

(26) Place the rear cover (34) on the casing (1).

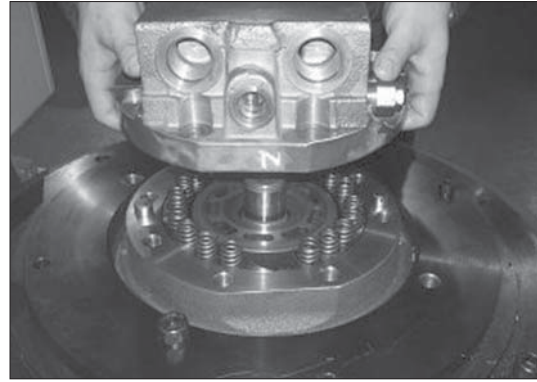

25098TM119

(27) Tighten the casing (1) and rear cover (34) specified torque with wrench bolt (54, 55) by using the impact wrench and torque wrench.

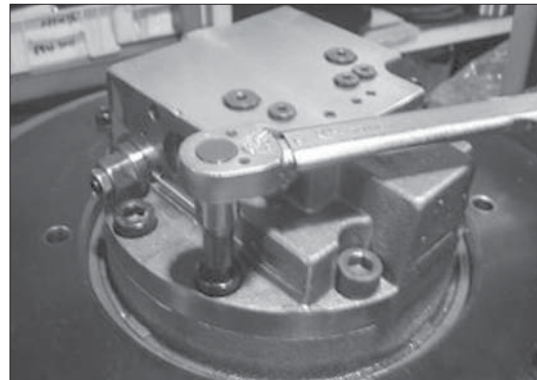

25098TM120

(28) Confirm the insert direction of the main spool assy (35) exactly and assemble it into the rear cover (34).

※ **Assure that four balance hole is directed VA port.**

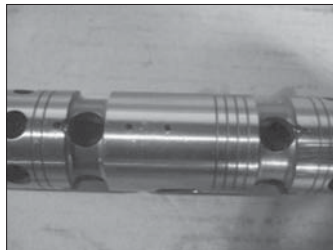

25098TM121

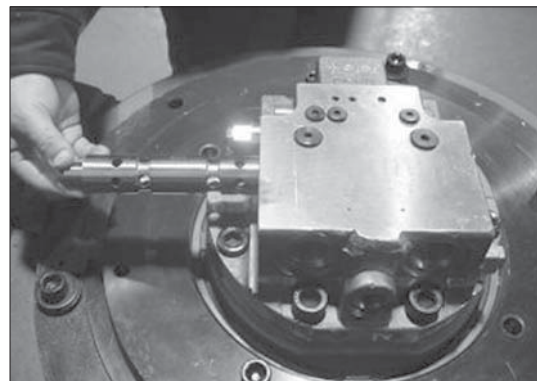

25098TM122

(29) Assemble the spring seat (41), spring (37) and main spool cover (36) into valve plate and tighten the wrench bolt (39, M12x35) by using L-wrench or impact wrench.

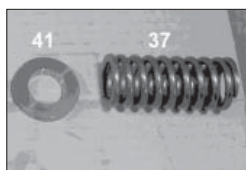

25098TM123

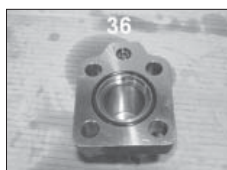

25098TM124

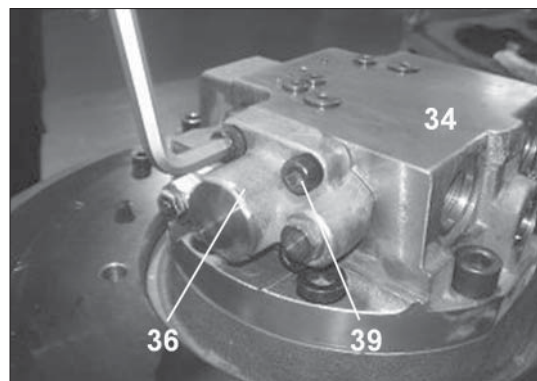

25098TM125

2) TRAVEL REDUCTION GEAR

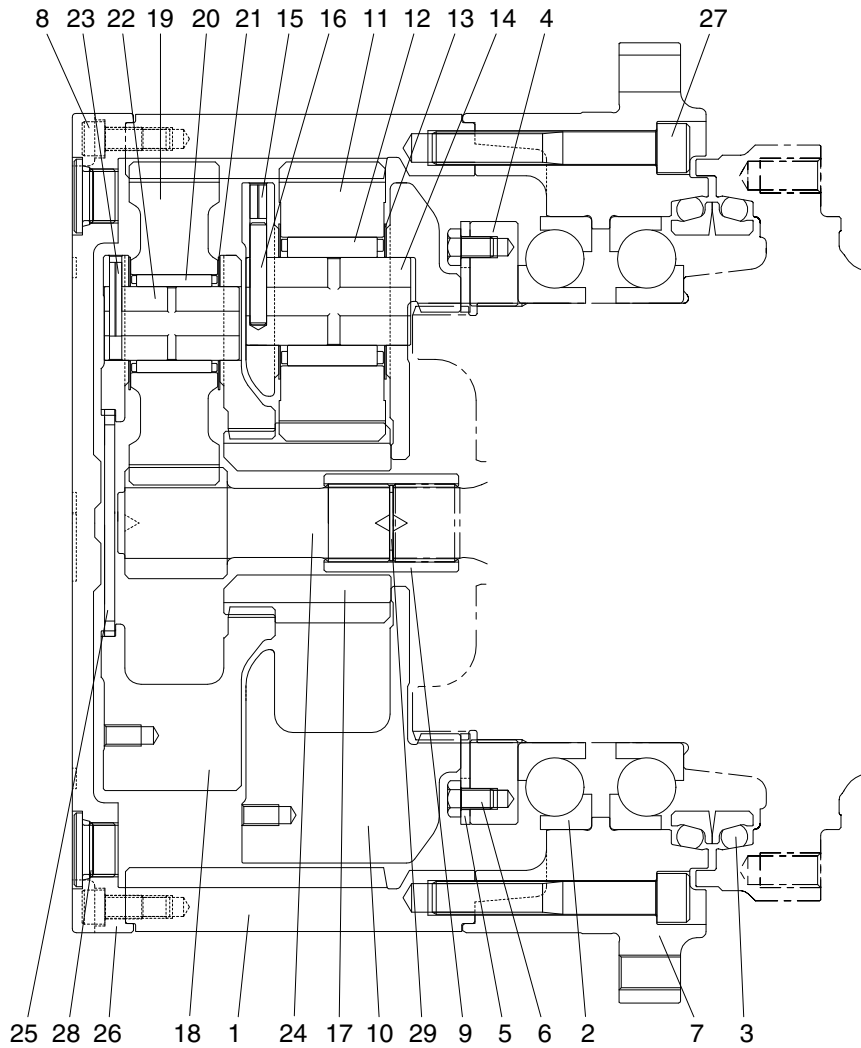

2209A2TM22

1	Ring gear	12	Needle bearing 2	22	Carrier pin 1
2	Ball bearing	13	Thrust washer 2	23	Spring pin 1
3	Floating seal assy	14	Carrier pin 2	24	Sun gear 1
4	Ring nut	15	Spring pin 2	25	Thrust plate
5	Lock plate	16	Solid pin 2	26	Cover
6	Hexagon bolt	17	Sun gear 2	27	Hexagon socket head bolt
7	Housing	18	Carrier 1	28	Plug
8	Hexagon socket head bolt	19	Planetary gear 1	29	Snap ring
9	Coupling	20	Needle bearing 1	30	Name plate
10	Carrier 2	21	Thrust washer 1	31	Rivet
11	Planetary gear 2				

6. DISASSEMBLING

1) GENERAL INSTRUCTIONS

- ▲ Combustibles such as white kerosene are used for washing parts.**
These combustibles are easily ignited, and could result in fire or injury.
Be very careful when using.
 - ▲ Internal parts are coated with gear oil during disassembling and are slippery.**
If a part slips off from your hand and falls, it could result in bodily injury or could damage the park.
Be very careful when handling.
- (1) Therefore, disassembling and assembling works should be performed on the clean place where dusts hardly gather.
Tools and kerosene to wash parts should also be clean and handled with great care.
- (2) Before disassembling, review the sectional drawing and prepare the required parts, depending on the purpose and the range of disassembling.
Seals, O-rings, etc., if once disassembled, are not reusable.
There are some parts that should be replaced as a subassembly.
Consult with the parts manual in advance.
- ▲ Take great care not to pinch your hand between parts while disassembling nor let fall parts on your foot while lifting them.**

2) DISASSEMBLING TRAVEL REDUCTION GEAR

(1) Preparation for disassembling

- ① The reduction units removed from excavator are usually covered with mud. Wash outside of propelling unit and dry it.
- ② Locate reducer in order for drain port to be at the lowest level, loosen taper screw plug of drain port, and drain oil from reduction gear.

※ While oil is still hot, inside of the unit may be pressurized.

▲ Take care of the hot oil gushing out of the unit when loosening the plug.

③ Mark for mating

Put marks on each mating parts when disassembling so as to reassemble correctly as before.

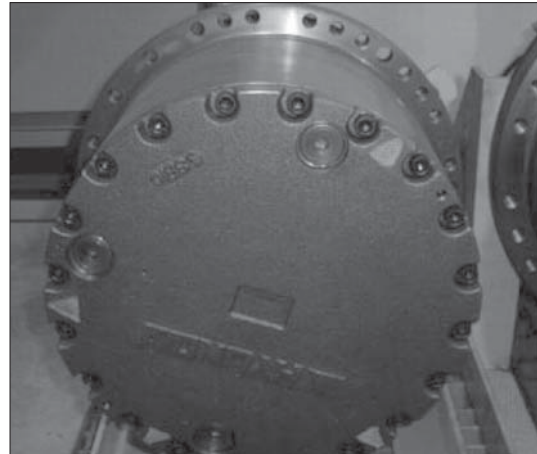

25098TM126

(2) Setting reduction unit (or whole propelling unit) on work stand for disassembling

- ① Remove 7/16-14UNC hexagon socket head bolts at 3 places from cover almost equally apart each other, and then install 7/16-14UNC eye bolts.

▲ Take great care not to pinch your hand between parts while disassembling nor let fall parts on your foot while lifting them.

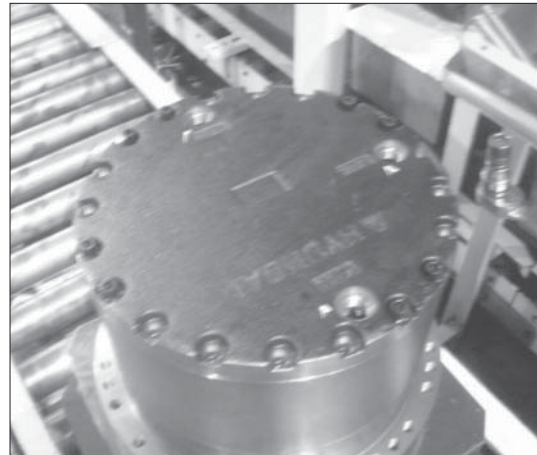

25098TM127

(3) Removing cover

- ① Remove the rest of 7/16-14UNC hexagon socket head bolts that secure cover and ring gear. Loosen all the socket bolts and then, disassemble cover.
- ② As the cover is adhered to ring gear, disassemble ring gear and cover by lightly hammering slantwise upward using sharpen punch inserted between the cover and ring gear.

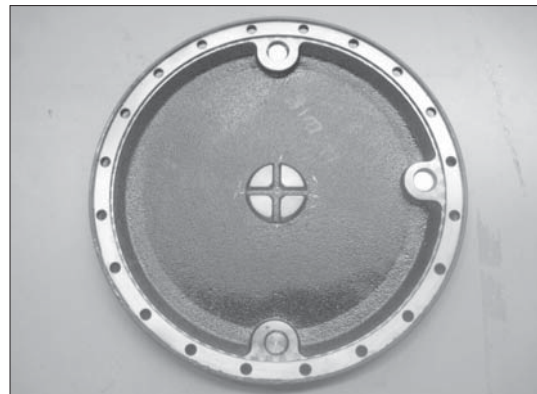

25098TM128

(4) Removing No.1 carrier sub assembly

- ① Screw three M10 eye-bolt in No.1 carrier and lift up and remove No.1 carrier assy.

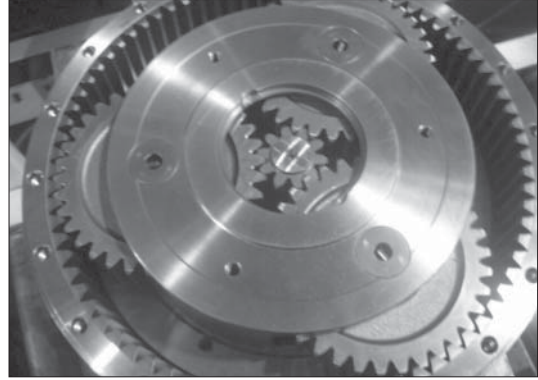

25098TM129

- ② Remove No.1 sun gear.

- ※ Be sure to maintain it vertical with the ground when disassembling No.1 sun gear.

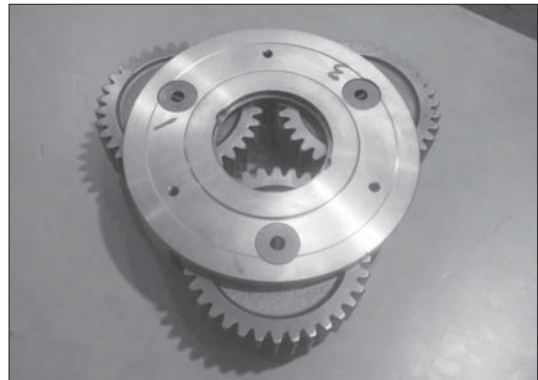

25098TM130

(5) Removing No.2 carrier sub assembly

- ① Screw three M10 eye-bolt in No.2 carrier and lift up and remove No.2 carrier assy.

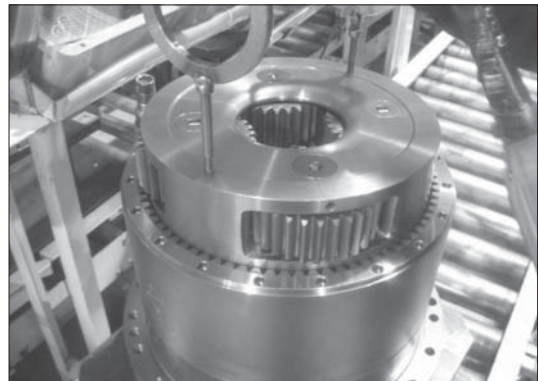

25098TM131

- ② Remove No.2 sun gear.

- ※ Be sure to maintain it vertical with the ground when disassembling No.1 sun gear.



25098TM132

(6) Removing coupling

- ① Remove coupling.

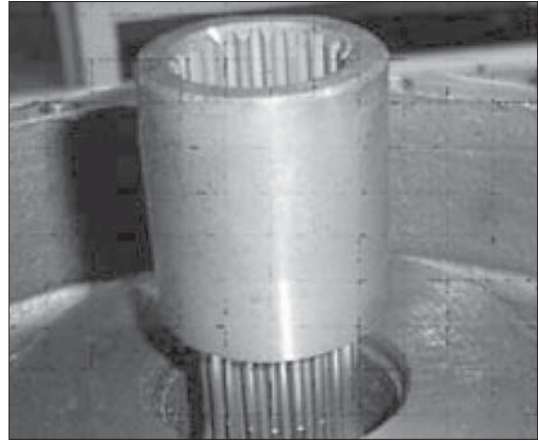

25098TM133

(7) Removing ring nut & lock plate

- ① Remove M12 hexagon head bolts that secure ring nut and lock plate.
 - ② Remove lock plate.
 - ③ Remove ring nut from motor casing.
- ※ Remove the ring nut by using the special tool for removing the ring nut.

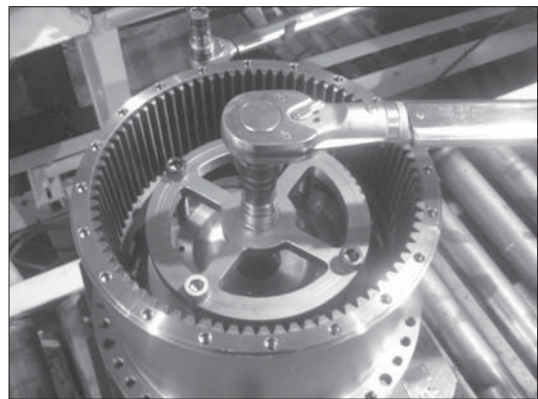

25098TM134

(8) Removing housing sub assembly & ring gear

- ① Screw 7/16-14UNC eye bolt in housing and lift up ring gear and housing assembly including angular bearing and floating seal.

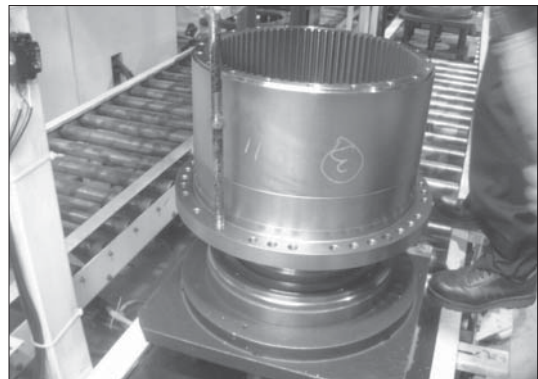

25098TM135

- ② Setting reduction unit on work stand for disassembling. Remove M16 hexagon socket head bolts that secure ring gear and housing assembly.

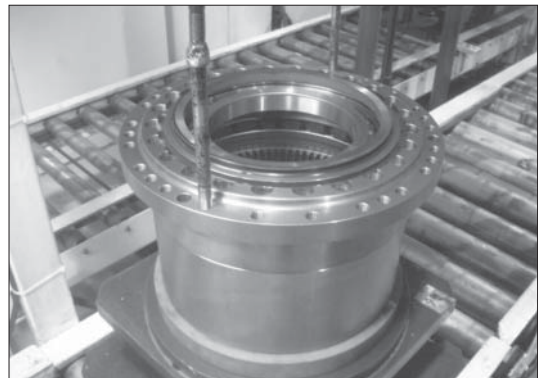

25098TM136

- ③ As the ring gear is adhered to housing assy, disassemble housing assy and ring gear by lightly hammering slantwise upward using sharpen punch inserted between the housing assy and ring gear.

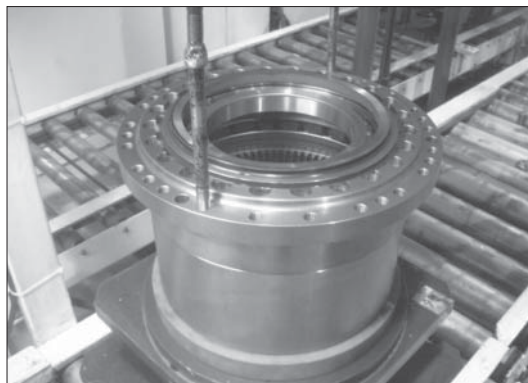

25098TM137

(9) Removing floating seal

- ① Lift up a piece of floating seal of motor side.

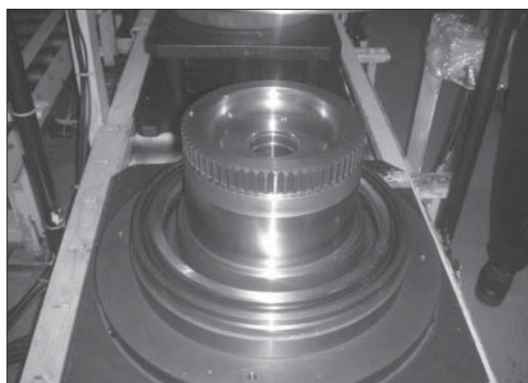

25098TM138

(10) Removing housing sub assembly

- ① Setting housing assembly on work stand for disassembling.
② After setting housing, lift up a piece of floating seal from housing and then remove it.

※ Don't disassemble angular bearing.

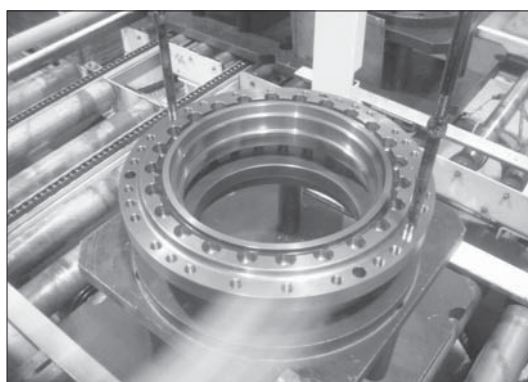

25098TM139

(11) Disassembling No.1 carrier

- ① Remove thrust plate.



25098TM140

- ② Knock spring pin fully into No.1 pin.



25098TM141

- ③ Remove planetary, thrust washer, No.1 pin, bearing from carrier.



25098TM142

(12) Disassembling No.2 carrier

- ① Knock spring pin fully into No.2 pin.
- ② Remove No.2 solid pin.
- ③ Remove planetary, thrust washer, No.2 pin, bearing from carrier.

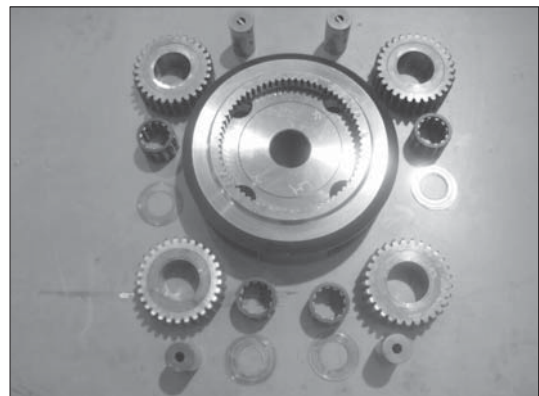

25098TM143

7. ASSEMBLY REDUTION UNIT

1) GENERAL NOTES

- (1) Clean every part by kerosene and dry them by air blow.
 - (2) Surfaces to be applied by loctite must be decreased by solvent.
 - (3) Check every part for any abnormal.
 - (4) Each hexagon socket head bolt should be used with loctite No.242 applied on its threads.
 - (5) Apply gear oil slightly on each part before assembling.
- ▲ Take great care not to pinch your hand between parts or tools while assembling nor let fall parts on your foot while lifting them.
Inspection before reassembling.

Thrust washer

- Check if there are seizure, abnormal wear or uneven wear.
- Check if wear is over the allowable limit.

Gear

- Check if there are pitting or seizure on the tooth surface.
- Check if there are cracks on the root of tooth by die check.

Bearing

- Rotate by hand to see if there are something unusual such as noise or uneven rotation.

Floating seal

- Check flaw or score on sliding surfaces or O-ring.

2) ASSEMBLING CARRIER 1 ASSY

- (1) Put No.1 carrier on a flat place.
- (2) Install No.1 needle bearing into No.1 planetary gear, put 2EA of No.1 thrust washer on both sides of planetary gear, and then, install it into carrier.

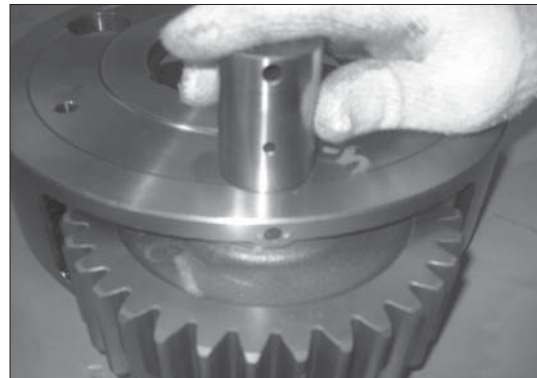

25098TM144

- (3) Install No.1 pin into No.1 carrier where the holes for No.1 pin are to be in line with those of No.1 carrier, and then, install spring pins into the holes.

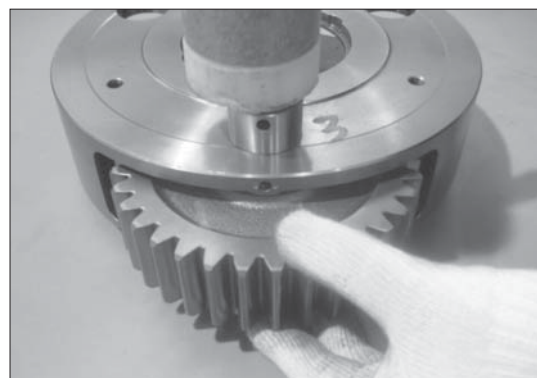

25098TM145

(4) Caulk carrier holes as shown on the picture.



25098TM146

3) ASSEMBLING CARRIER 2 ASSY

- (1) Put No.2 carrier on a flat place.
- (2) Install No.2 needle bearing into No.2 planetary gear, put 2EA of No.2 thrust washer on both sides of planetary gear, and then, install it into carrier.

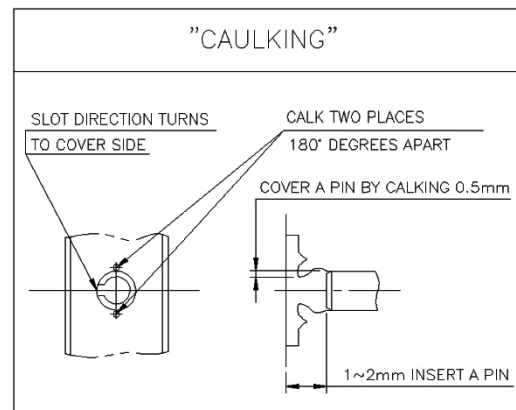

25098TM147

- (3) After install solid pin into the holes, install No.2 pin into No.1 carrier where the holes for No.1 pin are to be in line with those of No.1 carrier, and then, install spring pins into the holes.
- (4) Caulk carrier holes as shown on the picture.



25098TM148

4) ASSEMBLING FLOATING SEAL

- (1) Assemble floating seal into motor by use of pressing jig.
Grease the contact parts for floating seal which is assembled into motor.
- ※ Be sure to maintain it vertical with the ground when assembling bearing and floating seal.

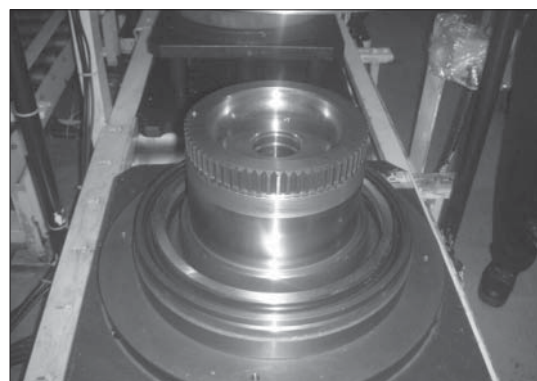

25098TM149

5) ASSEMBLING HOUSING

- (1) Heat housing at 60~70°C while clearing it out and then, assemble floating seal into housing by use of pressing jig.
- (2) Setting housing assembly on work stand for assembling.
Assemble angular bearing into housing by use of pressing jig.

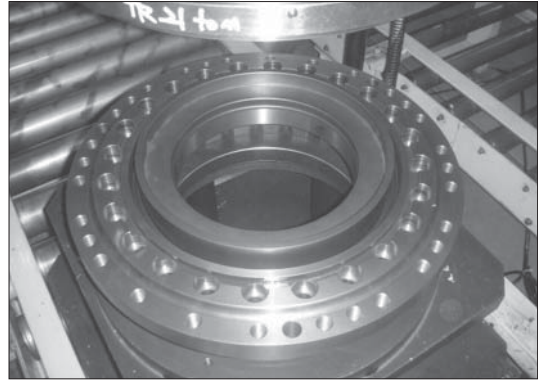

25098TM150

- (3) Assemble floating seal into housing by use of pressing jig.
Do not reuse the disassembling O-ring.
Grease the contact parts for floating seal which is assembled into housing.
- ※ Be sure to maintain it vertical with the ground when assembling bearing and floating seal.



25098TM151

6) ASSEMBLING HOUSING ASSY AND RING GEAR

- (1) Setting ring gear on work stand for assembling.
Apply loctite #515 on ring gear for housing without gap.

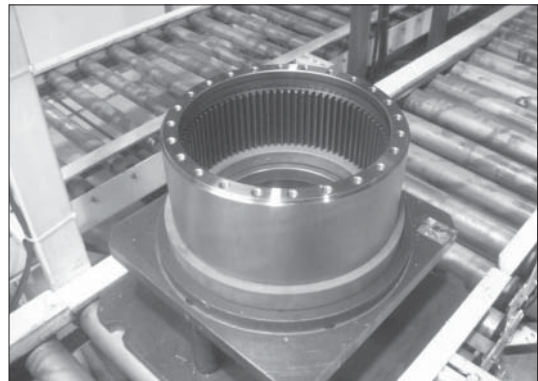

25098TM152

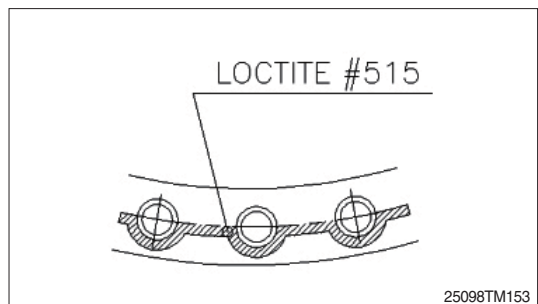

25098TM153

- (2) Install M16 eye-bolt on the tap of housing.
- (3) Lift housing and then, assemble into housing in order for bolt hole of ring gear and bolt hole of housing to be in line.
- (4) Apply loctite #242 on M16 hexagon socket head bolt, and then, bolt.

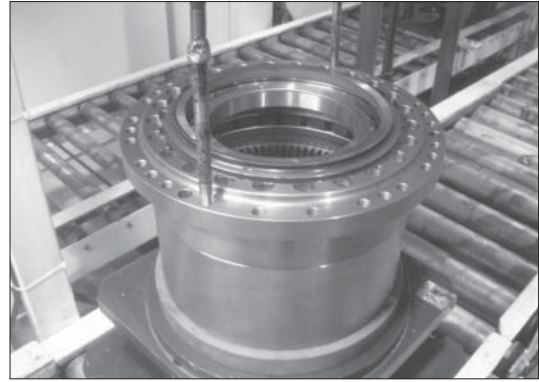

25098TM154

7) ASSEMBLING HOUSING ASSY AND MOTOR

- (1) Install 7/16-14UNC eye-bolt on the tap of ring gear.
 - (2) Assemble housing assembly into motor by use of hoist and eye-bolt.
- ※ Be sure to tighten eye-bolt deep enough.

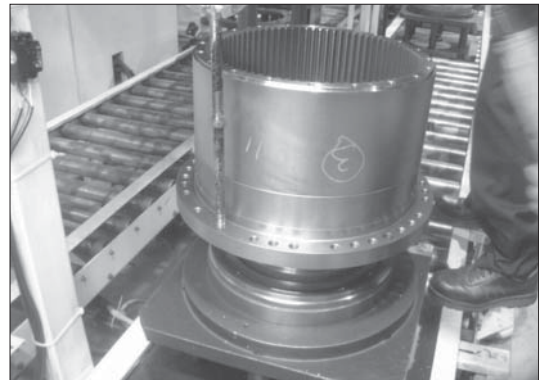

25098TM155

8) ASSEMBLING MAIN BEARING

- (1) Assemble angular bearing into housing by use of pressing jig.
- ※ Be sure to maintain it vertical with the ground when assembling bearing.



25098TM156

9) ASSEMBLING NUT RING AND LOCK PLATE

- (1) Tighten nut ring to specified torque, utilizing special tool.
 - Tightening torque : 60.3 kgf·m
(436 lbf·ft)
- (2) After install lock plate, apply loctite #242 on M12 hexagon head bolt, and then, bolt. Tighten M12 hexagon head bolt to specified torque, with torque wrench.

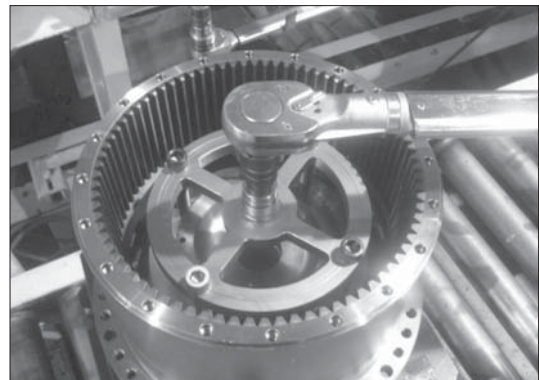

25098TM157

10) ASSEMBLING COUPLING

- (1) Install coupling on spline of the motor.

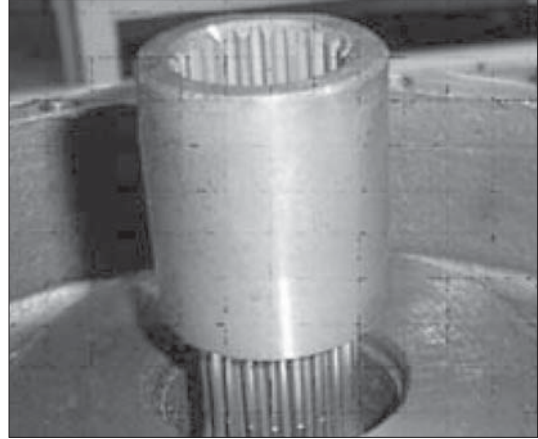

25098TM158

11) ASSEMBLING NO.2 CARRIER SUB ASSEMBLY

- (1) Install M10 eye-bolt on No.2 carrier assembly.
 - (2) Lift No.2 carrier assembly and then, slowly put it down on ring gear.
 - (3) Rotate planetary gear by hands and install on ring gear.
 - (4) Rotate No.2 carrier assembly by hands and install on motor.
- ※ Match pin hole of No.2 carrier with main (A, B) port of motor.

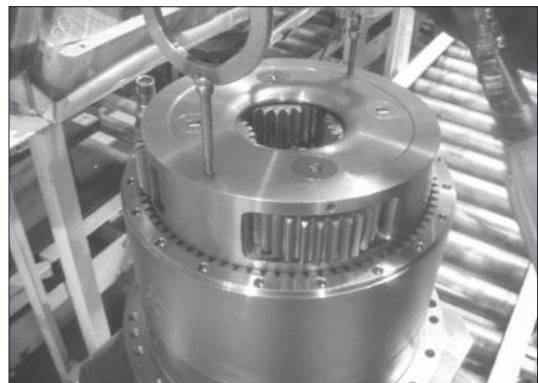

25098TM159

12) ASSEMBLING NO.2 SUN GEAR

- (1) Install No.2 sun gear on the No.2 planetary gear, matching teeth of them.

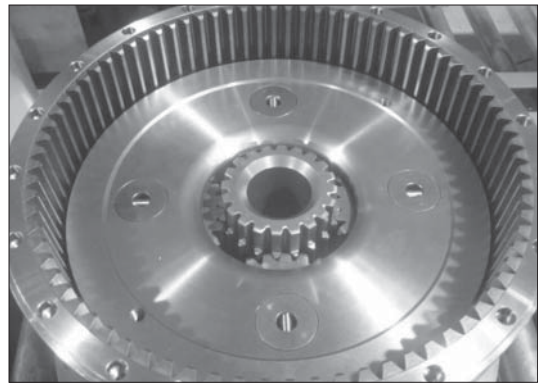

25098TM160

13) ASSEMBLING NO.1 CARRIER SUB ASSEMBLY

- (1) Install M10 eye-bolt on No.1 carrier assembly.
- (2) Lift No.1 carrier assembly and then, slowly put it down on ring gear.
- (3) Rotate planetary gear by hands and install on ring gear.
- (4) Rotate No.1 carrier assembly by hands and install on No.2 sun gear.

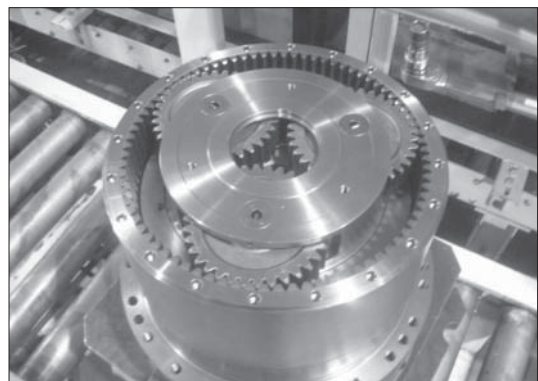

25098TM161

14) ASSEMBLING NO.1 SUN GEAR

- (1) Put down No.1 sun gear on No.1 carrier, maintaining it vertical with spline of coupling.
- (2) Install No.1 sun gear on No.1 planetary gear, matching their teeth.

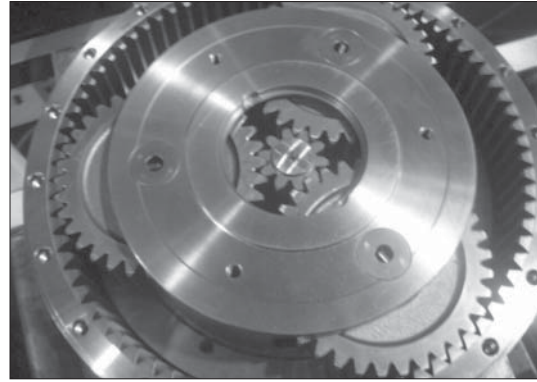

25098TM162

15) ASSEMBLING THRUST PLATE

- (1) Assembly thrust plate into No.1 carrier.
- ※ Edge of thrust plate direction turns to cover side.

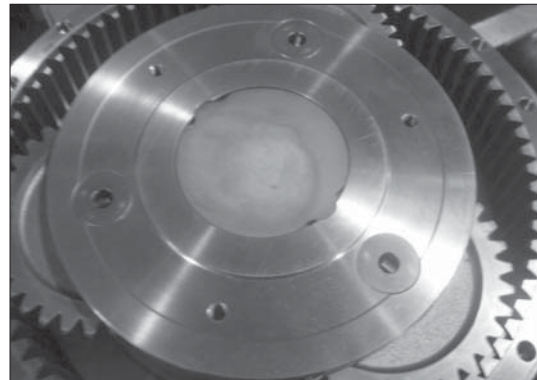

25098TM163

16) ASSEMBLING COVER

- (1) Apply loctite #515 on the ring gear for cover without gap.

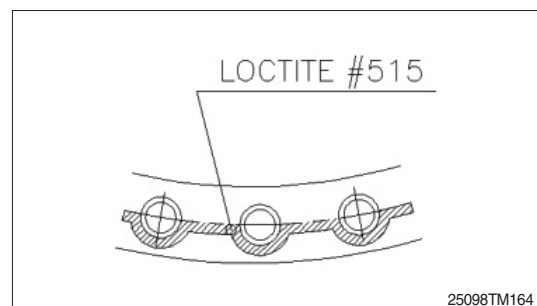

25098TM164

- (2) Put cover on ring gear, apply loctite #242 on 7/16-14UNC hexagon socket head bolt, and then, bolt.
Tighten 7/16-14UNC hexagon socket head bolt to specified torque, with torque wrench.

- (3) Fill gear oil (6 liter) into drain port.
- (4) Apply gear oil on PF3/4 hydraulic plug and then, bolt.

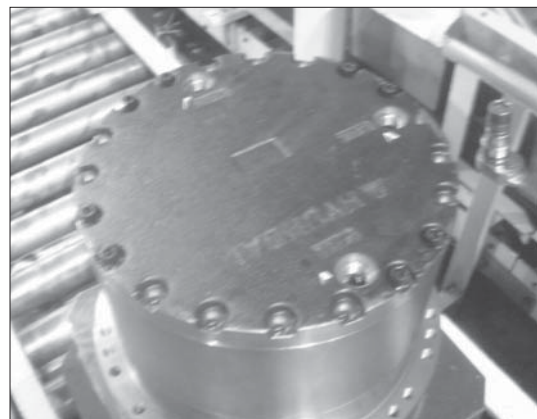

25098TM165