

## GROUP 6 RCV PEDAL

### 1. STRUCTURE

The casing (spacer) has the oil inlet port P (primary pressure), and the oil outlet port T (tank). In addition the secondary pressure is taken out through ports 1, 2, 3 and 4 provided at the bottom face.

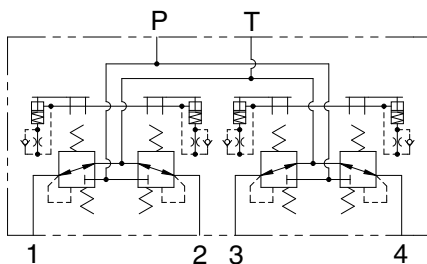
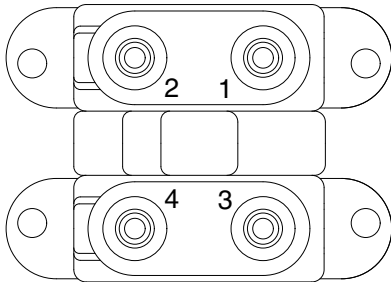
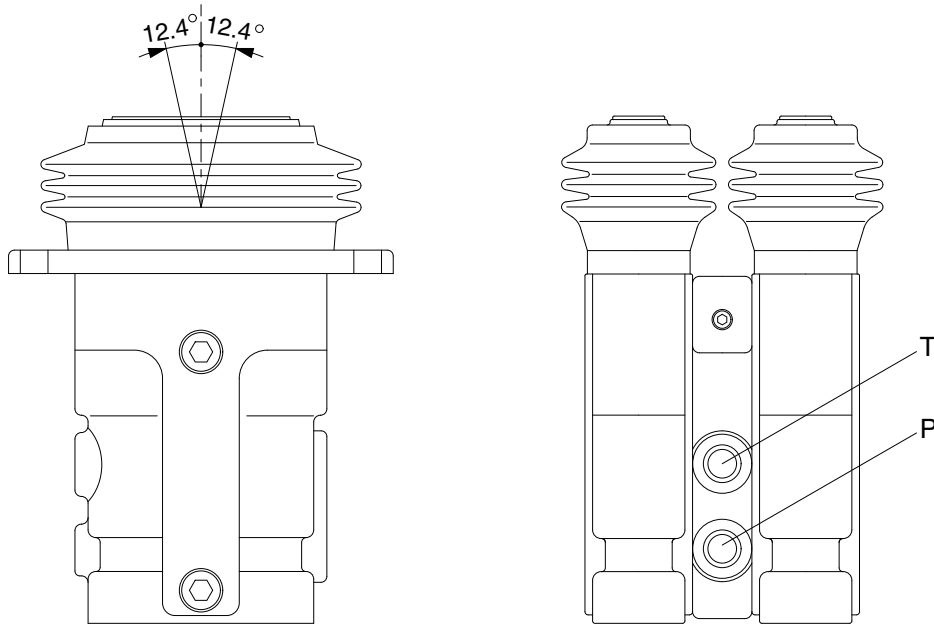

Hydraulic circuit

| Port | Port                  | Port size |
|------|-----------------------|-----------|
| P    | Pilot oil inlet port  | PF 1/4    |
| T    | Pilot oil return port |           |
| 1    | Travel (LH, Forward)  |           |
| 2    | Travel (LH, Backward) |           |
| 3    | Travel (RH, Forward)  |           |
| 4    | Travel (RH, Backward) |           |

21092RP01

## CROSS SECTION

The construction of the RCV pedal is shown in the below drawing. The casing has vertical holes in which reducing valves are assembled.

The pressure reducing section is composed of the spool (8), spring (6) for setting secondary pressure, return spring (10), stopper (9), and spring seat (7). The spring for setting the secondary pressure has been generally so preset that the secondary pressure is 5 to 19 kgf/cm<sup>2</sup> (depending on the type). The spool is pushed against the push rod (14) by the return spring.

When the push rod is pushed down by tilting pedal, the spring seat comes down simultaneously and changes setting of the secondary pressure spring.

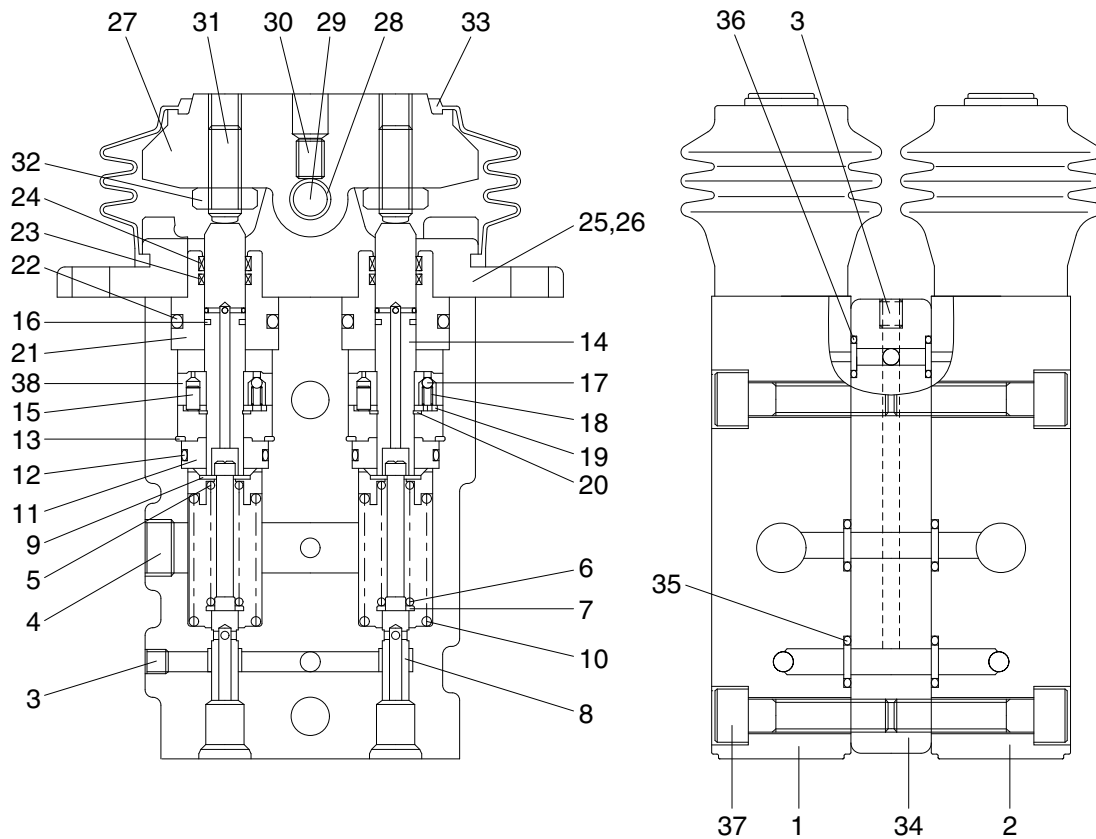

21092RP02

|    |             |    |             |    |             |
|----|-------------|----|-------------|----|-------------|
| 1  | Body(1)     | 14 | Push rod    | 27 | Cam         |
| 2  | Body(2)     | 15 | Spring pin  | 28 | Bushing     |
| 3  | Plug        | 16 | Seal        | 29 | Cam shaft   |
| 4  | Plug        | 17 | Steel ball  | 30 | Set screw   |
| 5  | Spring seat | 18 | Spring      | 31 | Set screw   |
| 6  | Spring      | 19 | Plate       | 32 | Nut         |
| 7  | Spring seat | 20 | Snap ring   | 33 | Bellows     |
| 8  | Spool       | 21 | Plug        | 34 | Space       |
| 9  | Stopper     | 22 | O-ring      | 35 | O-ring      |
| 10 | Spring      | 23 | Rod seal    | 36 | O-ring      |
| 11 | Rod guide   | 24 | Dust seal   | 37 | Socket bolt |
| 12 | O-ring      | 25 | Cover       | 38 | Piston      |
| 13 | Snap ring   | 26 | Socket bolt |    |             |

## 2. FUNCTION

### 1) FUNDAMENTAL FUNCTIONS

The pilot valve is a valve controls the spool stroke, direction, etc of a main control valve. This function is carried out by providing the spring at one end of the main control valve spool and applying the output pressure (secondary pressure) of the pilot valve to the other end.

For this function to be carried out satisfactorily, the pilot valve is composed of the following elements.

- (1) Inlet port (P) where oil is supplied from hydraulic pump.
- (2) Output port (1, 2, 3 & 4) to apply pressure supplied from inlet port to ends of control valve spools.
- (3) Tank port (T) necessary to control the above output pressure.
- (4) Spool to connect output port to inlet port tank port.
- (5) Mechanical means to control output pressure, including springs that work on the above spools.

### 2) FUNCTIONS OF MAJOR SECTIONS

The functions of the spool (8) are to receive the supply oil pressure from the hydraulic pump at its port P, and to change over oil paths to determine whether the pressure oil of port P is led to output ports 1, 2, 3 & 4 or the output spool to determine the output pressure.

The spring (6) works on this spool to determine the output pressure.

The change the deflection of this spring, the push rod (14) is inserted and can slide in the plug (21). For the purpose of changing th displacement of the push rod through the cam (27) and adjusting nut (32) are provided the pedal that can be tilted in any direction around the fulcrum of the cam (27) center.

The spring (10) works on the casing (1) and spring seat (7) and tries to return the push rod (14) to the zero-displacement position irrespective of the output pressure, securing its resetting to the center position.

This also has the effect of a reaction spring to give appropriate control feeling to the operator.

### 3) OPERATION

The operation of the pilot valve will be described on the basis of the hydraulic circuit diagram shown below and the attached operation explanation drawing.

The diagram shown below is the typical application example of the pilot valve.

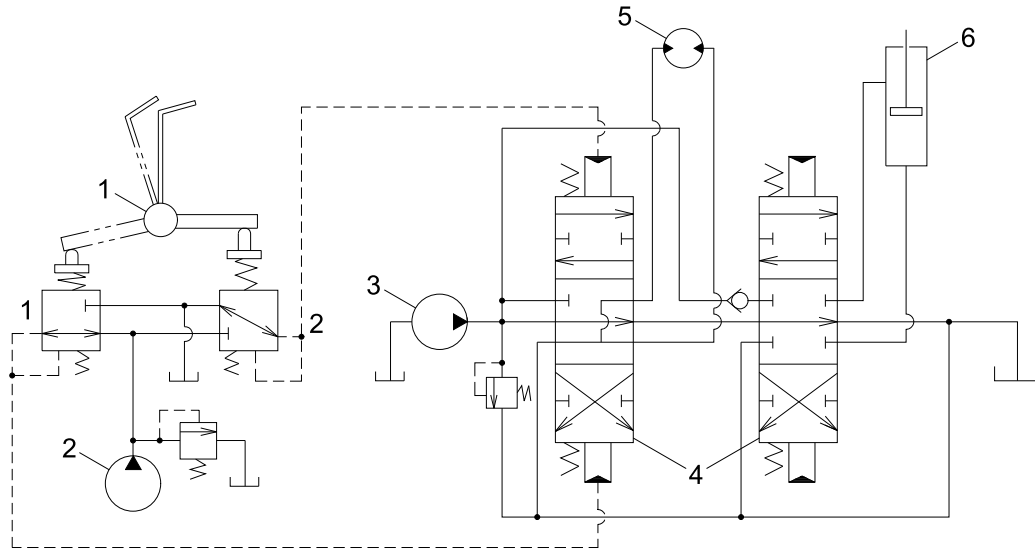

36072SF01

1 Pilot valve  
2 Pilot pump

3 Main pump  
4 Main control valve

5 Hydraulic motor  
6 Hydraulic cylinder

(1) Case where pedal is in neutral position

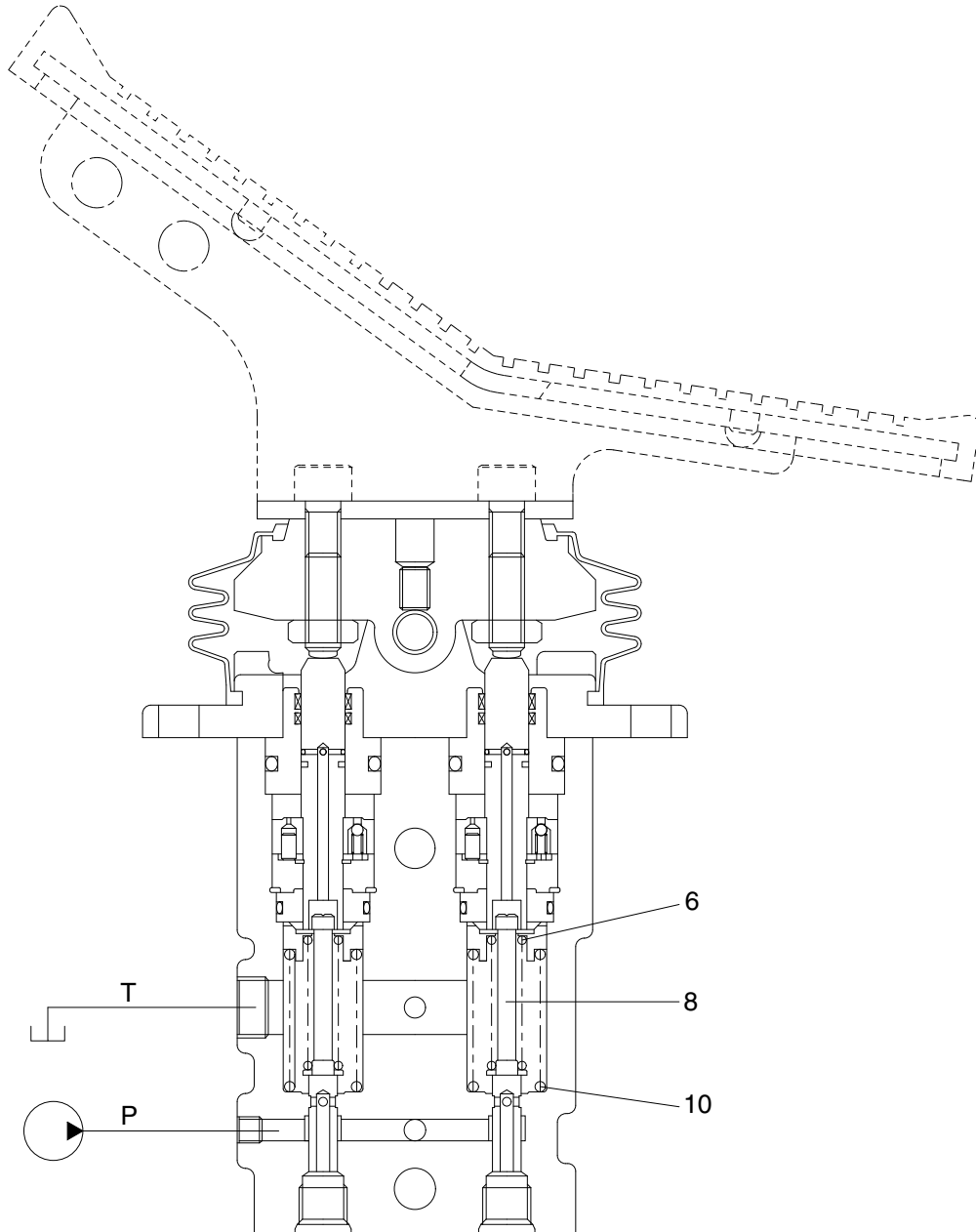

21092RP03

The force of the spring (6) that determines the output pressure of the pilot valve is not applied to the spool (8). Therefore, the spool is pushed up by the spring (10) to the position of port 2 in the operation explanation drawing. Then, since the output port is connected to tank port T only, the output port pressure becomes equal to tank pressure.

## (2) Case where pedal is tilted

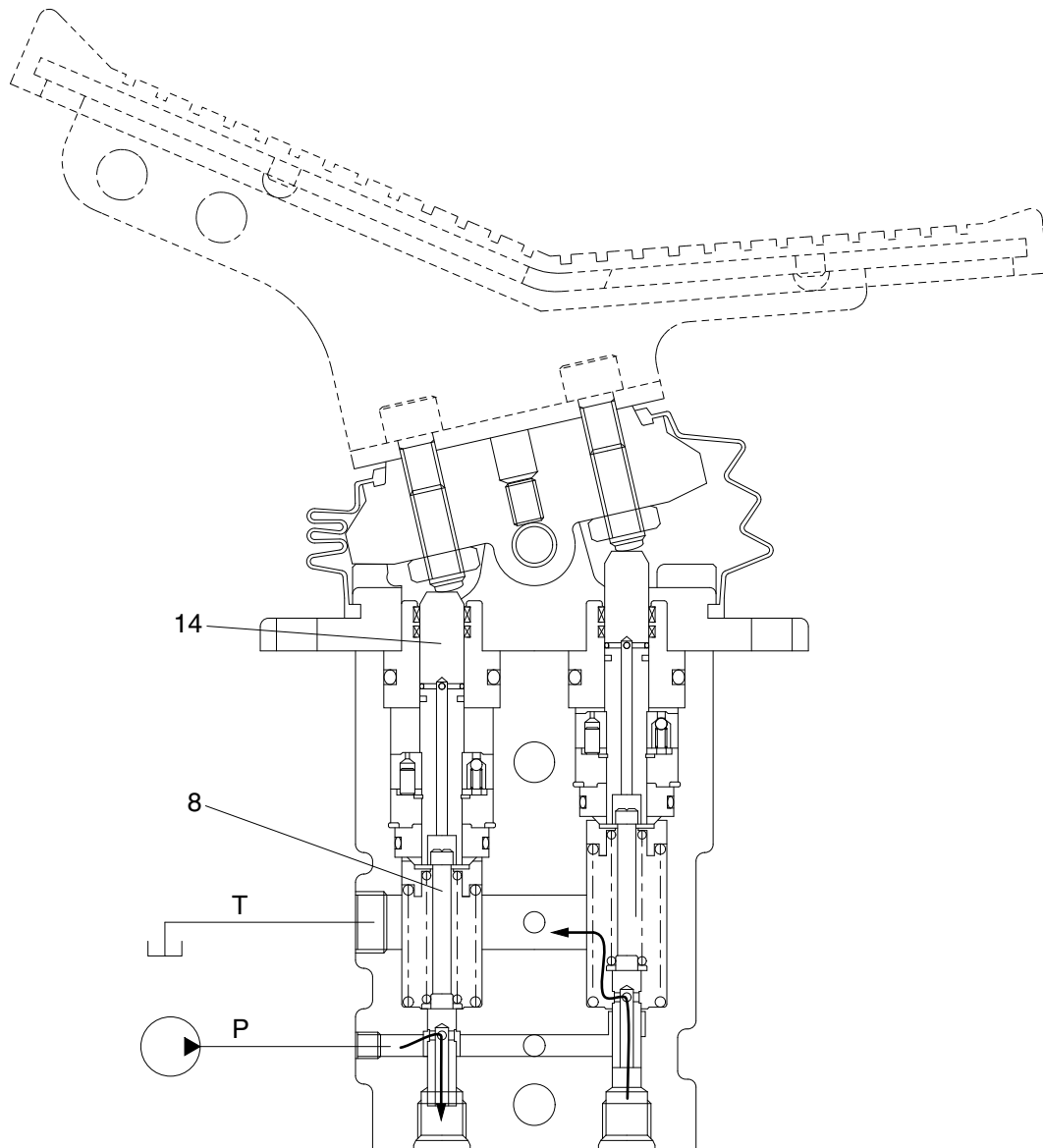

21092RP04

When the push rod (14) is stroked, the spool (8) moves downwards.

Then port P is connected with port 1, and the oil supplied from the pilot pump flows through port 1 to generate the pressure.

When the pressure at port 1 increases to the value corresponding to the spring force set by tilting the handle, the hydraulic pressure force balances with the spring force. If the pressure at port 1 increases higher than the set pressure, port P is disconnected from port 1 and port T is connected with port 1. If it decreases lower than the set pressure, port P is connected with port 1 and port T is disconnected from port 1.

In this manner the secondary pressure is kept at the constant value.

Besides, in some type, when the handle is tilted more than a certain angle, the upper end of the spool contacts with inside bottom of the push rod and the output pressure is left to be connected with port P.