

## GROUP 3 ELECTRICAL SYSTEM

### 1. WHEN STARTING SWITCH IS TURNED ON, MONITOR PANEL DISPLAY DOES NOT APPEAR

- Before disconnecting the connector, always turn the starting switch OFF.
- Before carrying out below procedure, check all the related connectors are properly inserted and fuse No.7 and 8 burnt out.
- After checking, insert the disconnected connectors again immediately unless otherwise specified.

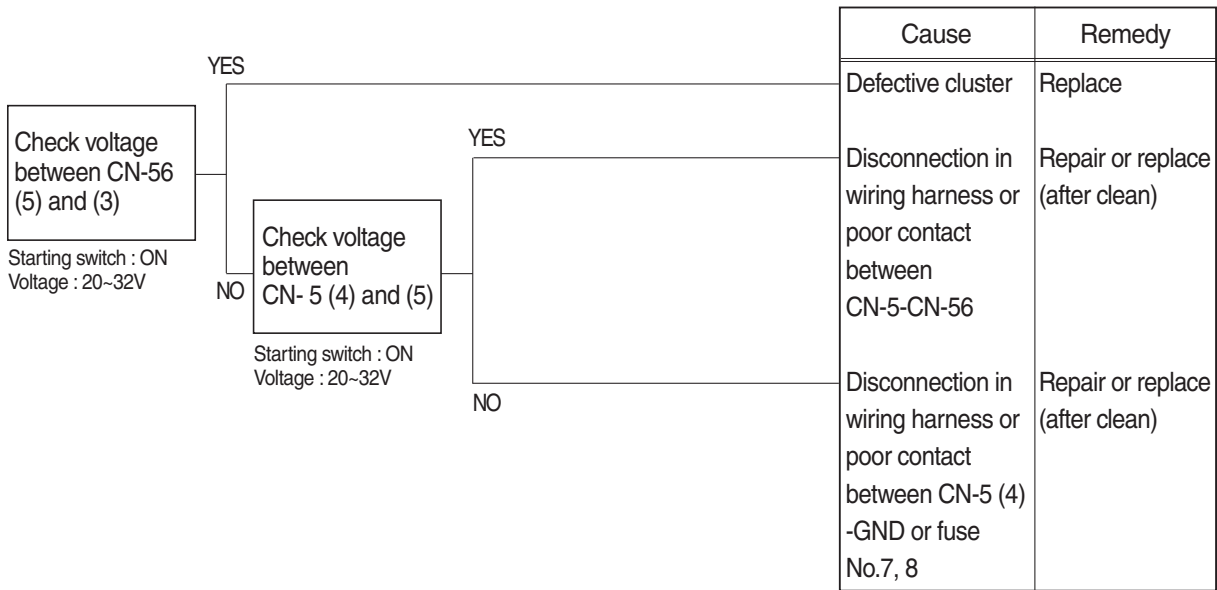

#### Check voltage

YES	20~32V
NO	0V

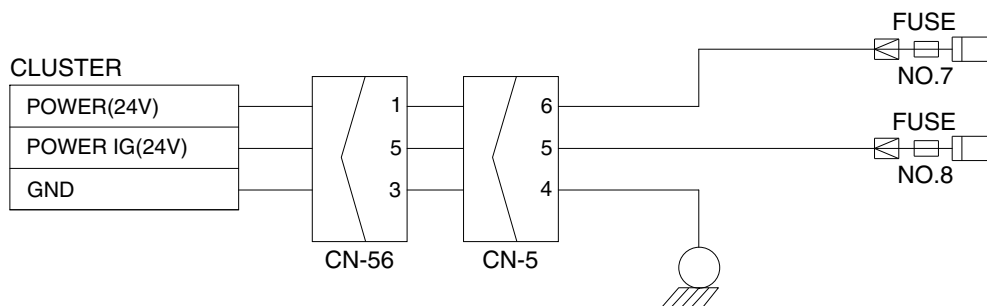

1409S6ES01

2.  **COMMUNICATION ERROR FLASHES ON THE CLUSTER (HCESPN 840, FMI 2)**

- Before disconnecting the connector, always turn the starting switch OFF.
- Before carrying out below procedure, check all the related connectors are properly inserted.
- After checking, insert the disconnected connectors again immediately unless otherwise specified.

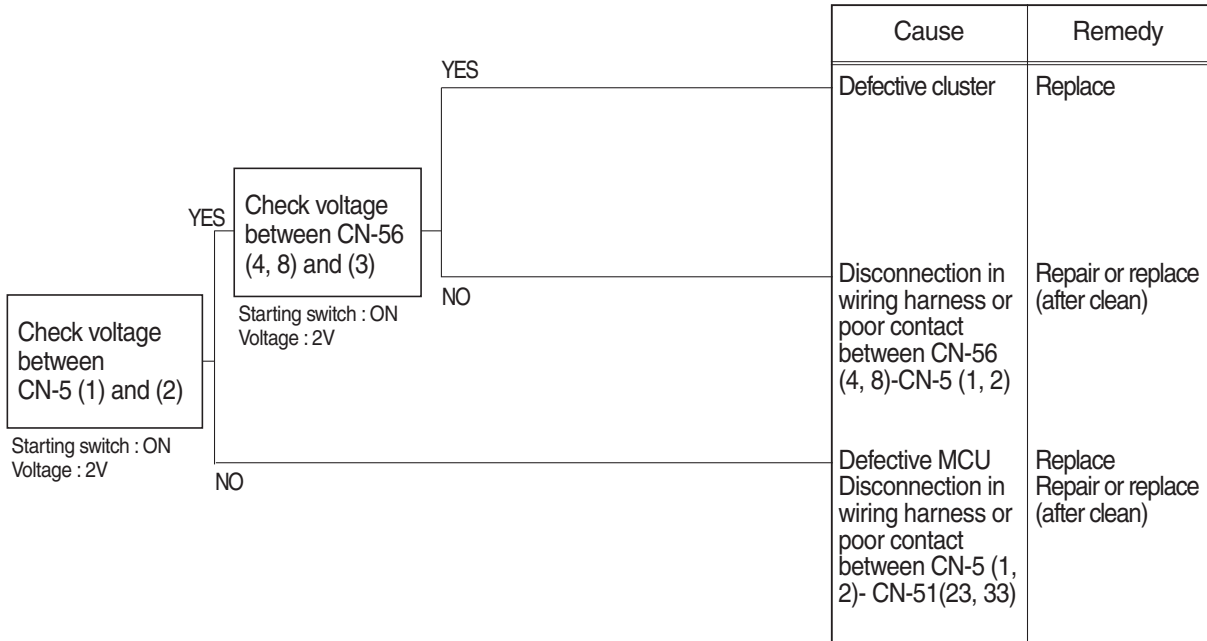

**Check voltage**

YES	2V
NO	0V

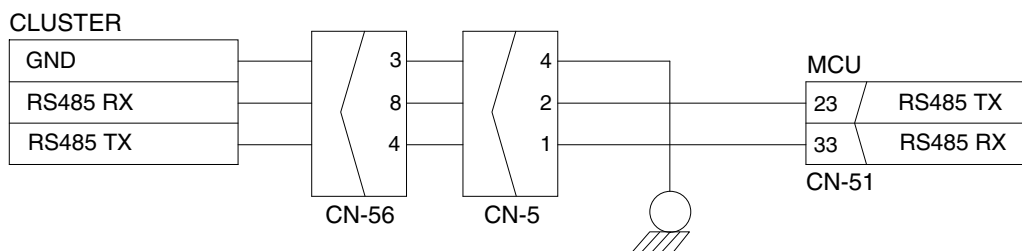

### 3. BATTERY CHARGING WARNING LAMP LIGHTS UP (Starting switch : ON)

- Before disconnecting the connector, always turn the starting switch OFF.
- Before carrying out below procedure, check all the related connectors are properly inserted.
- After checking, insert the disconnected connectors again immediately unless otherwise specified.

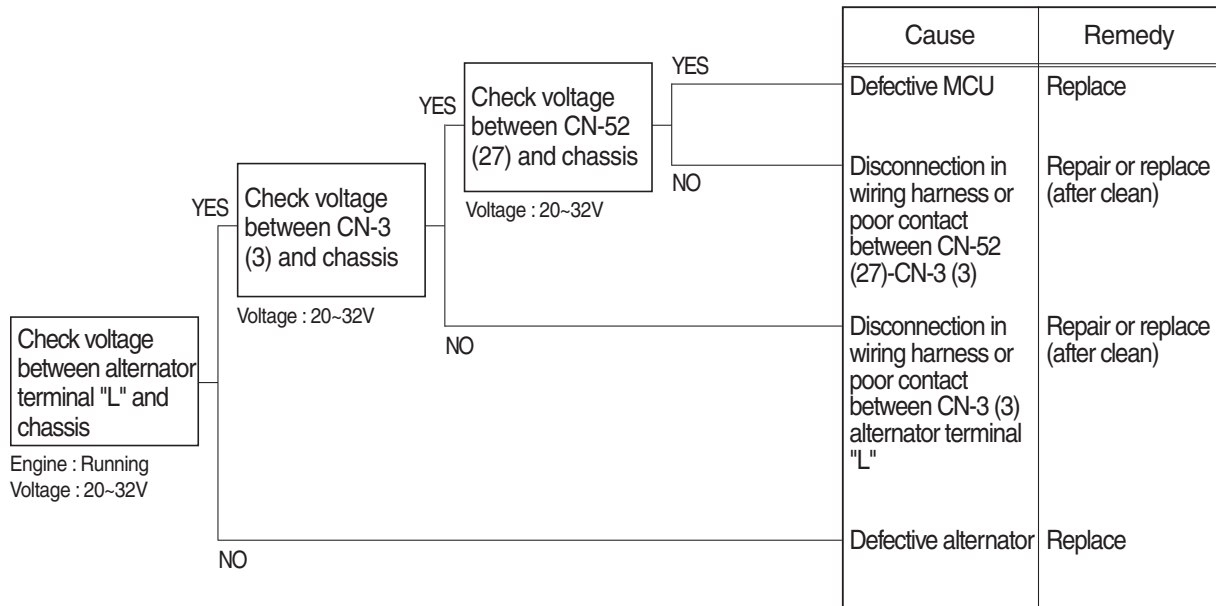

#### Check voltage

YES	20~32V
NO	0V

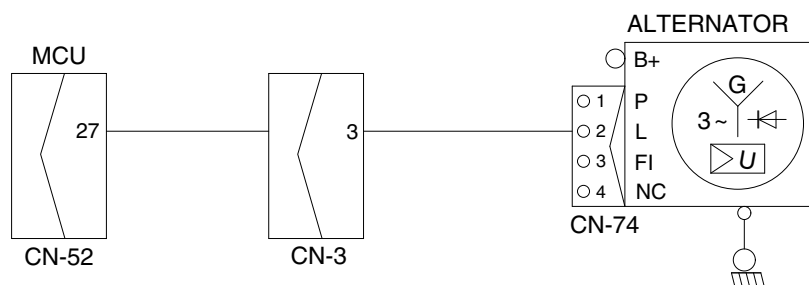

1409S6ES03

#### 4. WHEN COOLANT OVERHEAT WARNING LAMP LIGHTS UP (engine is started)

- Before disconnecting the connector, always turn the starting switch OFF.
- Before carrying out below procedure, check all the related connectors are properly inserted.
- After checking, insert the disconnected connectors again immediately unless otherwise specified.

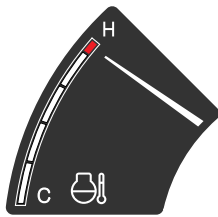
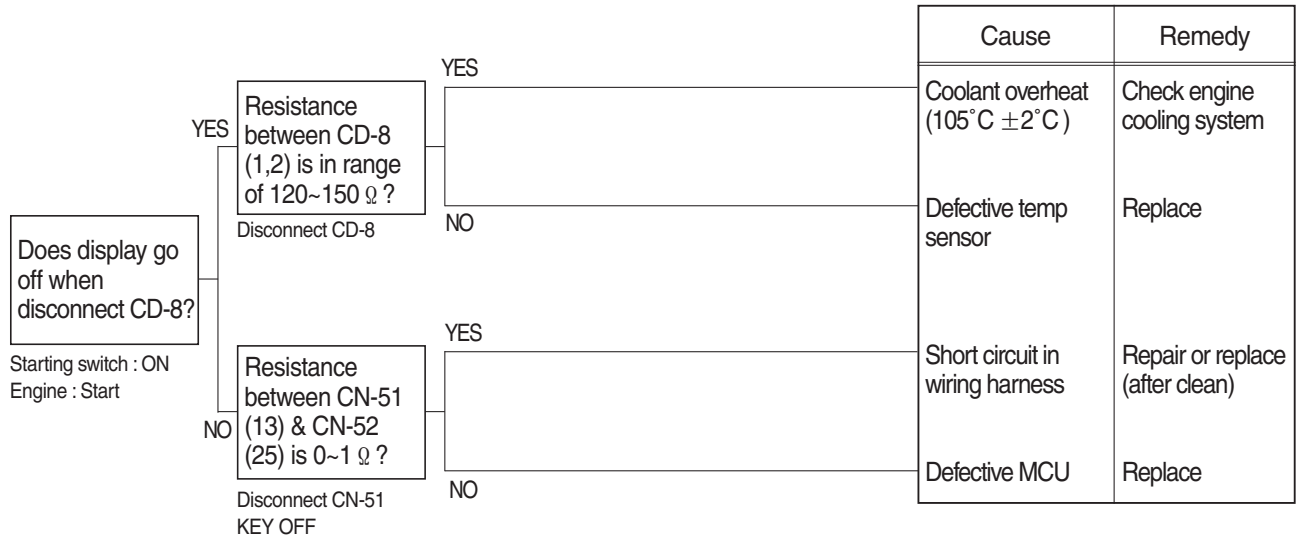

Check Table

Temperature (°C)	0	25	50	80	95
Resistance (k Ω)	30~37	9.3~10.7	3.2~3.8	1.0~1.3	0.7~0.8

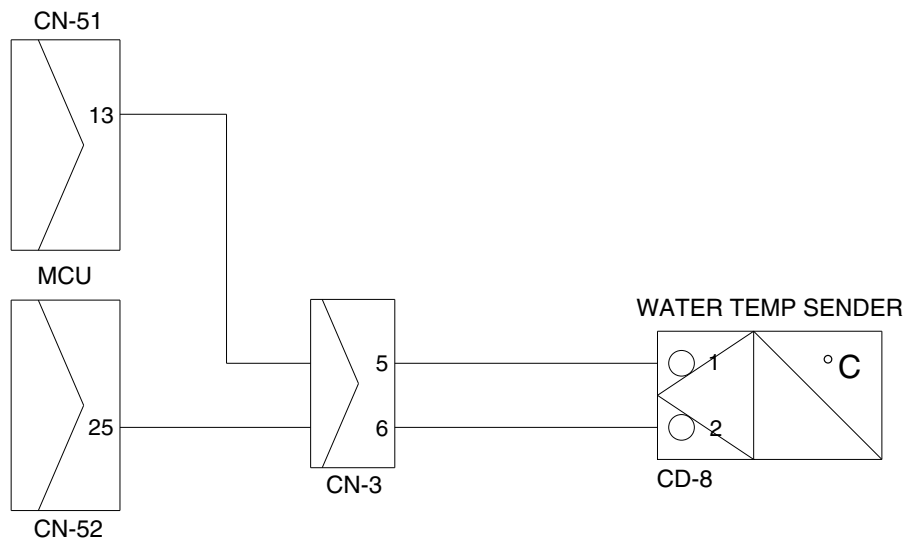

1409S6ES04

## 5. WHEN AIR CLEANER WARNING LAMP LIGHTS UP (engine is started)

- Before disconnecting the connector, always turn the starting switch OFF.
- Before carrying out below procedure, check all the related connectors are properly inserted.
- After checking, insert the disconnected connectors again immediately unless otherwise specified.

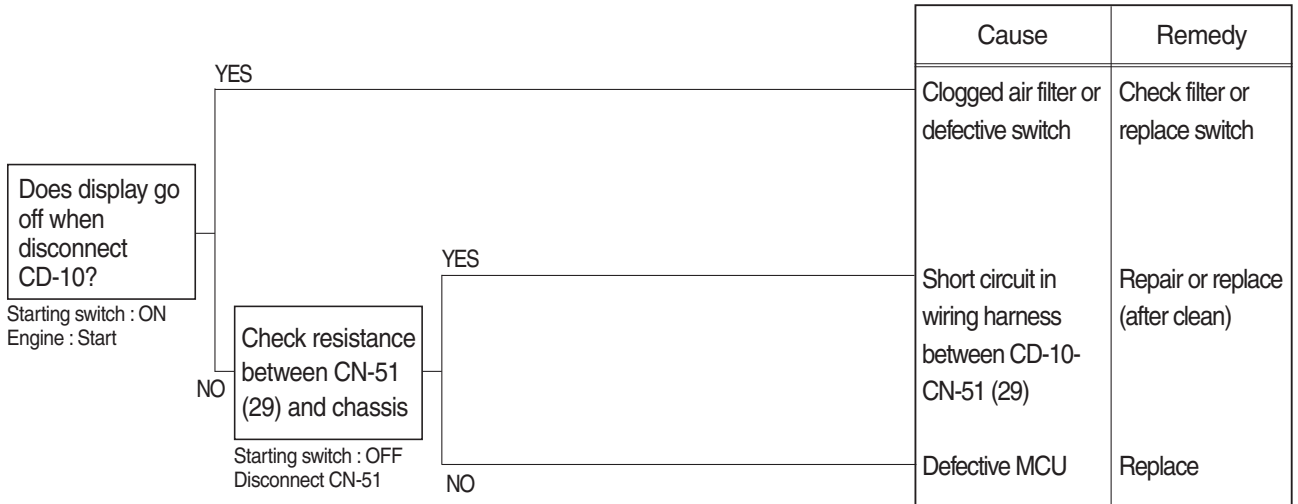

### Check resistance

YES	MAX 1Ω
NO	MIN 1MΩ

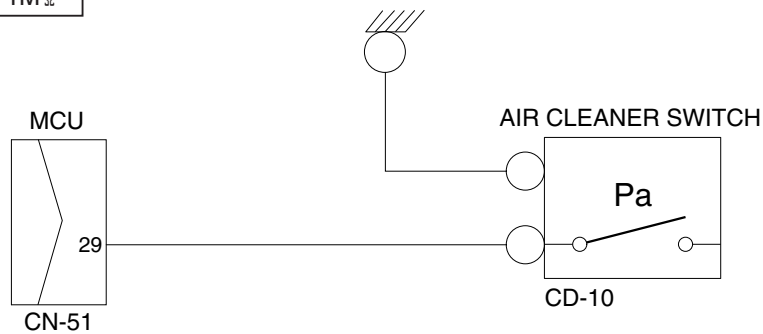

1409S6ES05

## 6. WHEN ENGINE OIL PRESSURE WARNING LAMP LIGHTS UP (engine is started)

- Before disconnecting the connector, always turn the starting switch OFF.
- Before carrying out below procedure, check all the related connectors are properly inserted.
- After checking, insert the disconnected connectors again immediately unless otherwise specified.

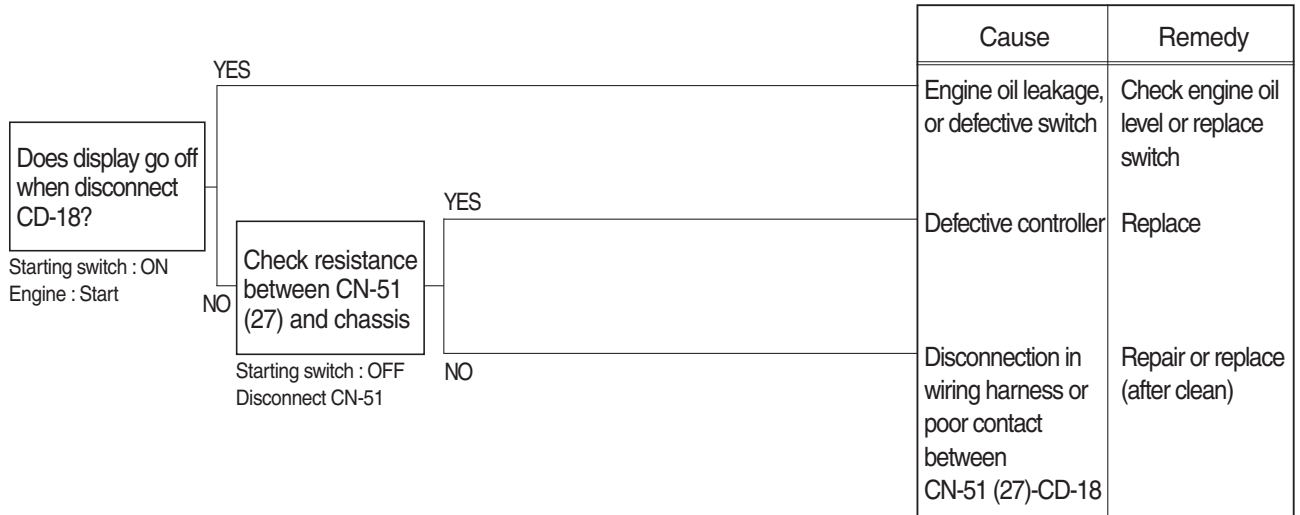

### Check resistance

YES	MAX 1Ω
NO	MIN 1MΩ

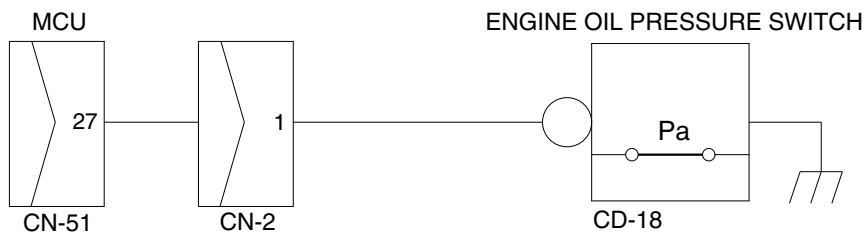

1409S6ES06

## 7. WHEN HYDRAULIC OIL TEMPERATURE WARNING LAMP LIGHTS UP (engine is started)

- Before disconnecting the connector, always turn the starting switch OFF.
- Before carrying out below procedure, check all the related connectors are properly inserted.
- After checking, insert the disconnected connectors again immediately unless otherwise specified.

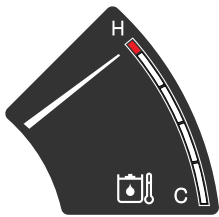
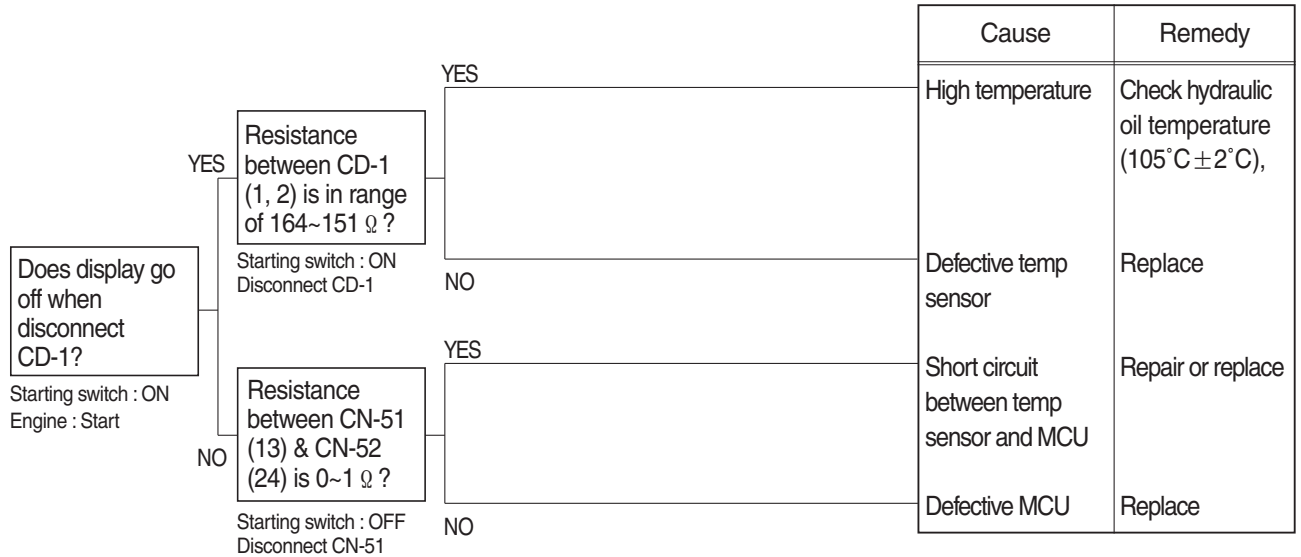

Check Table

Temperature (°C)	~ -30	~ -10	~ 0	~ 40	~ 70	~ 80	~ 90	~ 100	105~
Resistance (k Ω)	22.22 ~31.78	8.16 ~10.74	5.18 ~ 6.6	1.06 ~1.28	0.39 ~0.476	0.322 ~0.298	0.243 ~0.219	0.185 ~0.167	0.164 0.151

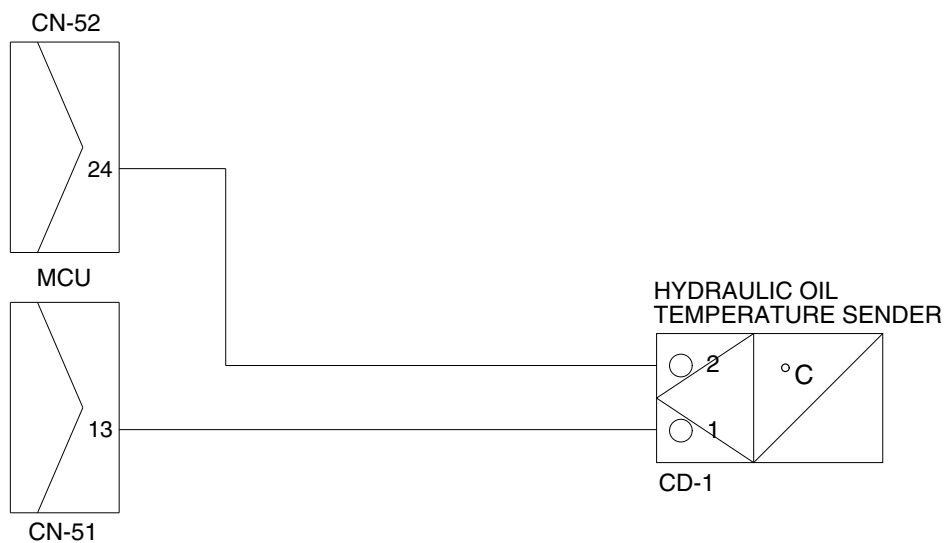

1409S6ES07

## 8. WHEN COOLANT TEMPERATURE GAUGE DOES NOT OPERATE (HCESPN 304, FMI 3 or 4)

- Before disconnecting the connector, always turn the starting switch OFF.
- Before carrying out below procedure, check all the related connectors are properly inserted.
- After checking, insert the disconnected connectors again immediately unless otherwise specified.

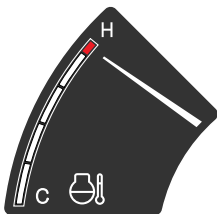
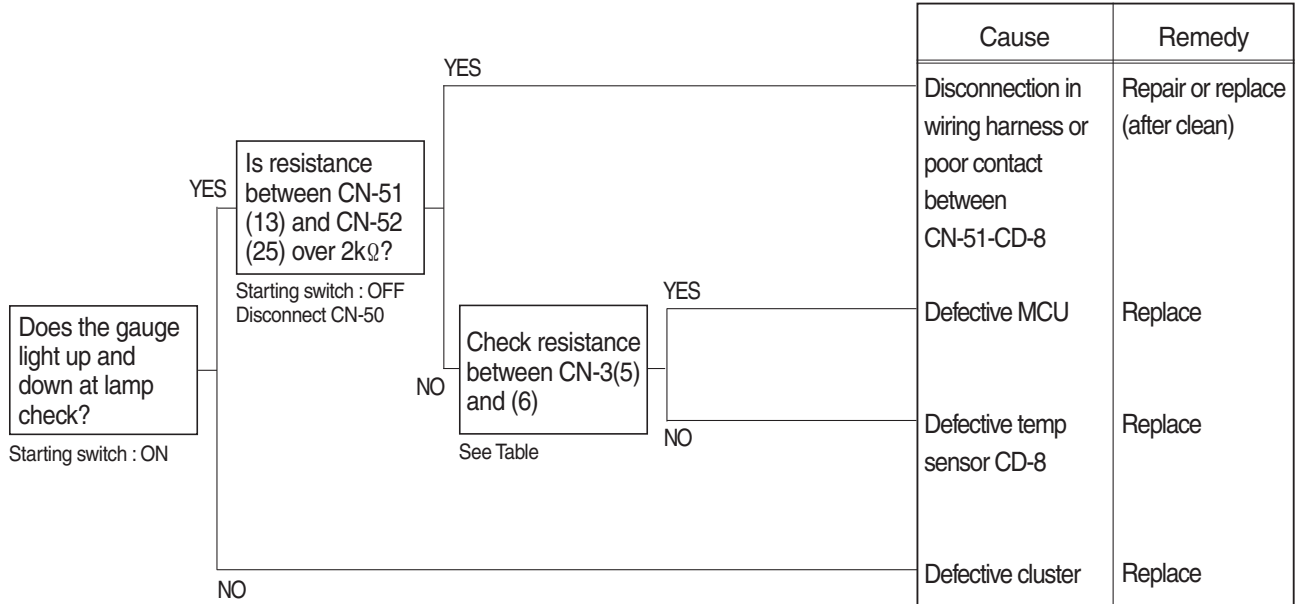

Check Table

Temperature (°C)	0	25	50	80	95
Resistance (k Ω)	30~37	9.3~10.7	3.2~3.8	1.0~1.3	0.7~0.8

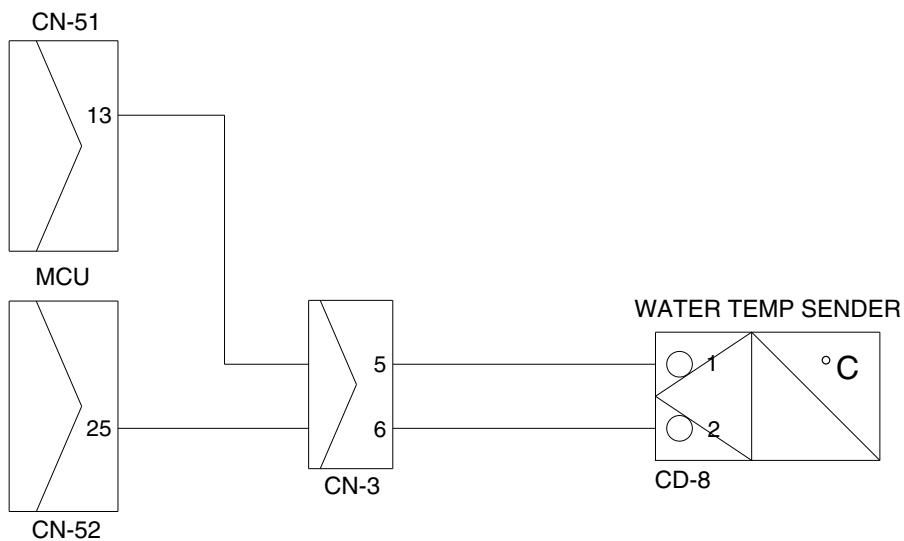

1409S6ES04



## 9. WHEN FUEL GAUGE DOES NOT OPERATE (HCESPN 301, FMI 5 or 6)

- Before disconnecting the connector, always turn the starting switch OFF.
- Before carrying out below procedure, check all the related connectors are properly inserted.
- After checking, insert the disconnected connectors again immediately unless otherwise specified.

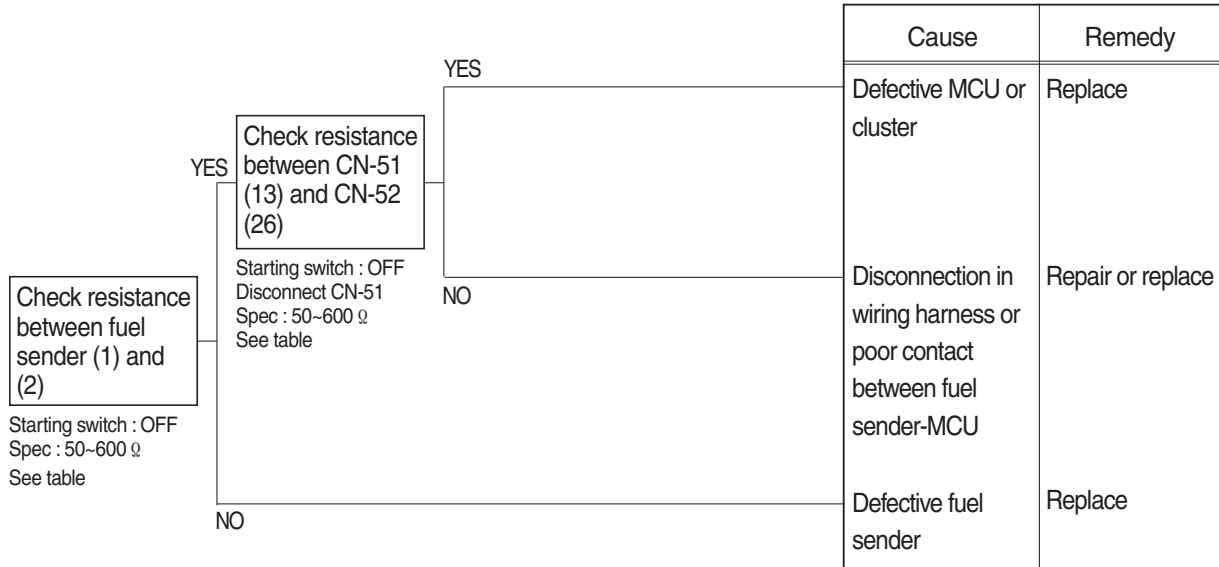

Check Table



Range	Resistance ( Ω )	Range	Resistance ( Ω )
Full	50	5/12	400
11/12	100	4/12	450
10/12	150	3/12	500
9/12	200	2/12	550
8/12	250	1/12	600
7/12	300	Empty warning	700
6/12	350	-	-

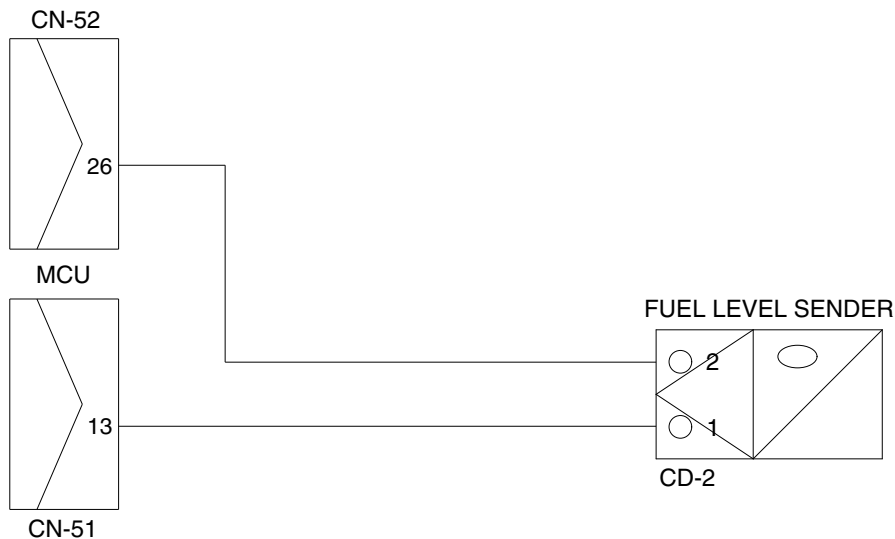

1409S6ES09

## 10. WHEN SAFETY SOLENOID DOES NOT OPERATE

- Before disconnecting the connector, always turn the starting switch OFF.
- Before carrying out below procedure, check all the related connectors are properly inserted and fuse No.23 burnt out.
- After checking, insert the disconnected connectors again immediately unless otherwise specified.

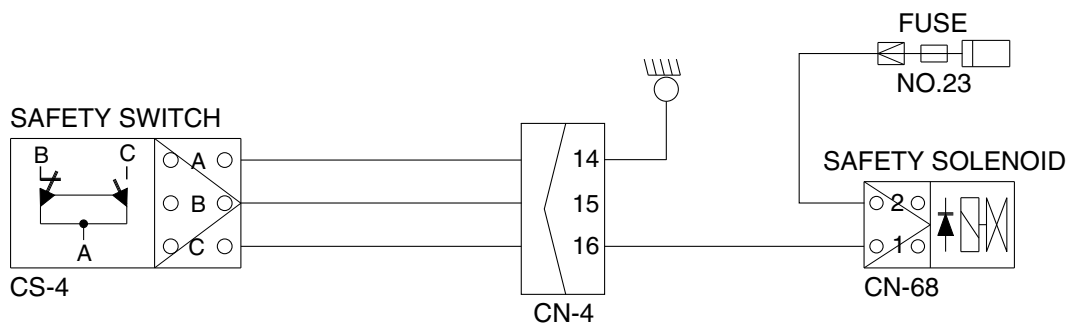
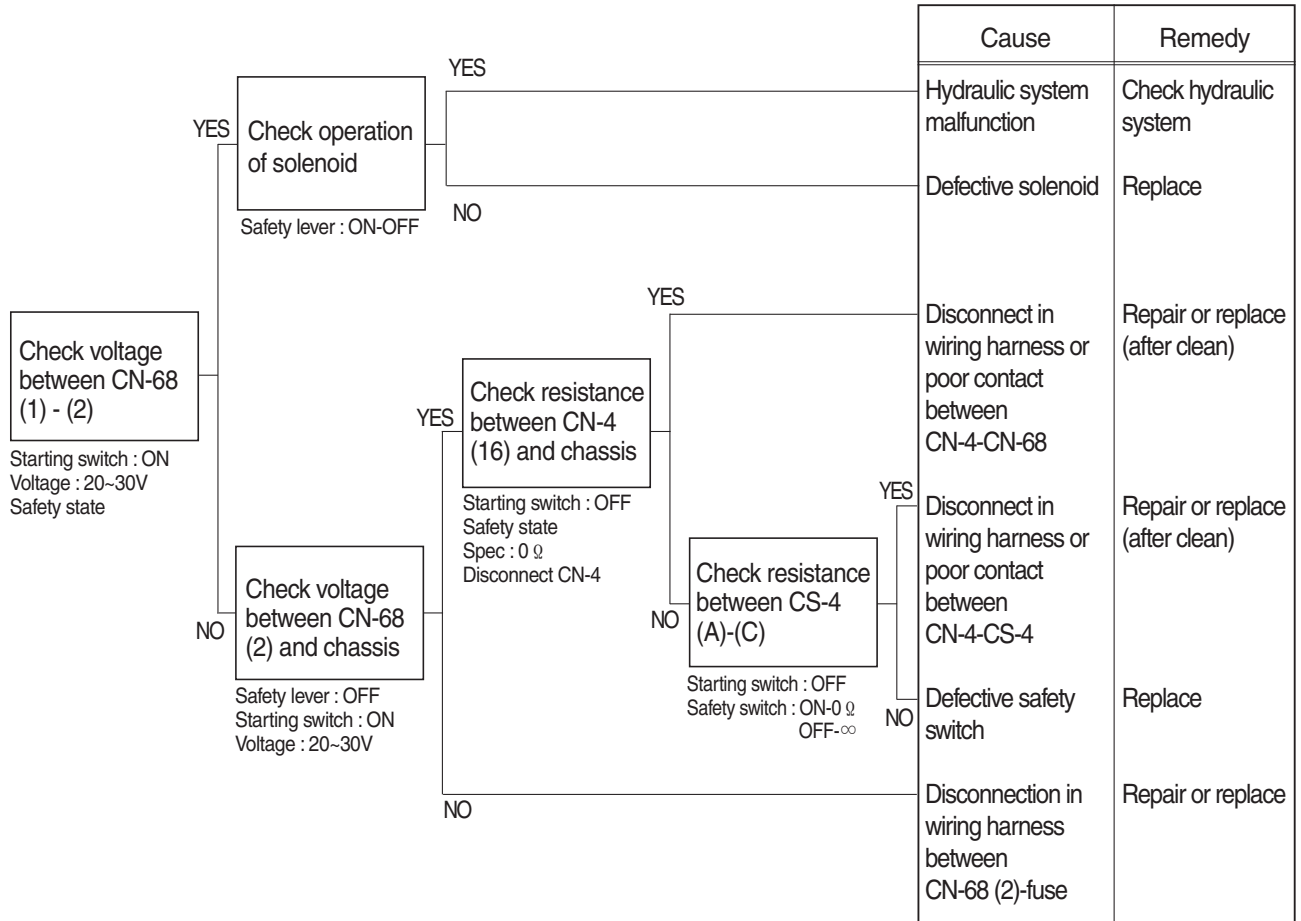

21096ES10

## 11. WHEN TRAVEL SPEED 1, 2 DOES NOT OPERATE (HCESPN 167, FMI 5 or 6)

- Before disconnecting the connector, always turn the starting switch OFF.
- Before carrying out below procedure, check all the related connectors are properly inserted and fuse No. 25 burnt out.
- After checking, insert the disconnected connectors again immediately unless otherwise specified.

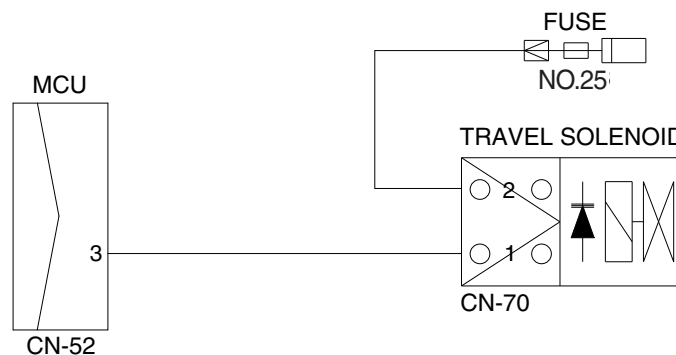
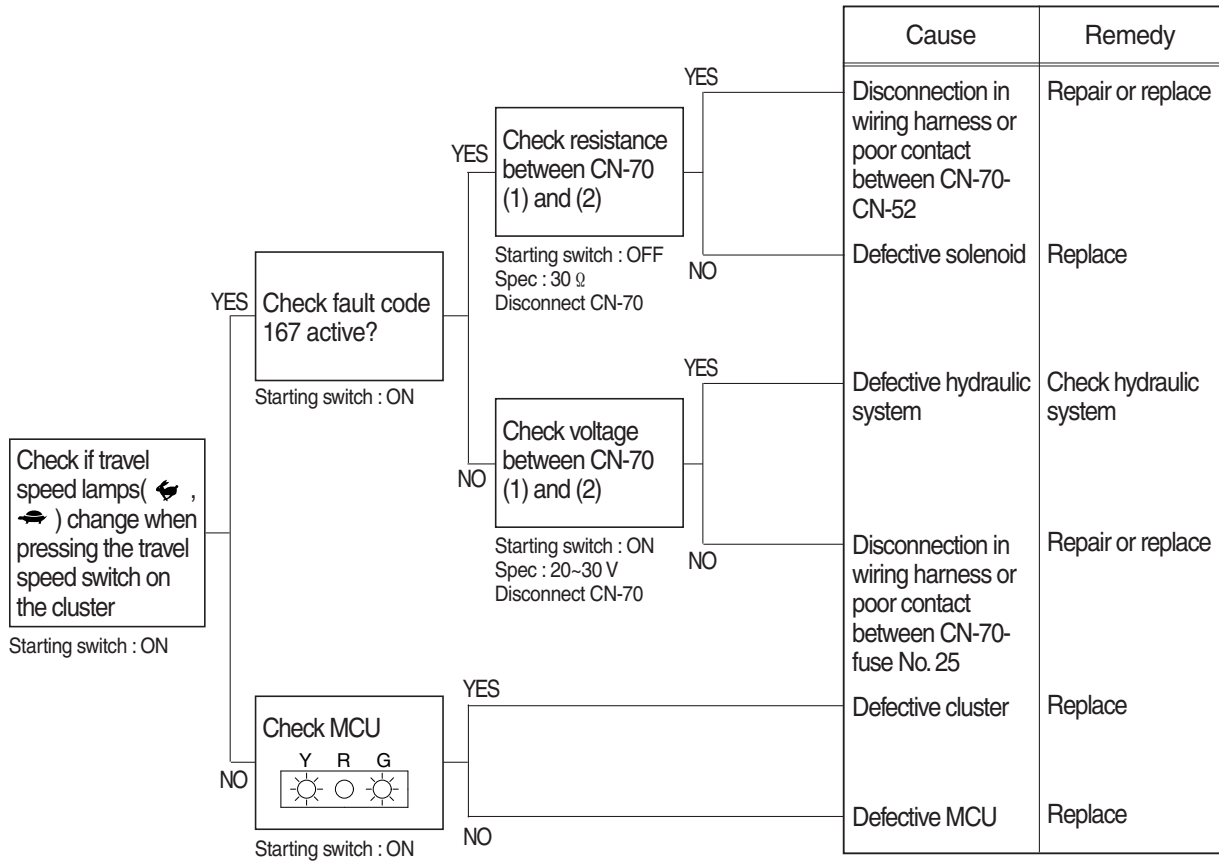

1409S6ES11

## 12. WHEN ENGINE DOES NOT START ( lights up condition)

- Check supply of the power at engine stop solenoid while starting switch is ON.
- Before disconnecting the connector, always turn the starting switch OFF.
- Before carrying out below procedure, check all the related connectors are properly inserted and fuse No. 4, 13 and 20 burnt out.
- After checking, insert the disconnected connectors again immediately unless otherwise specified.

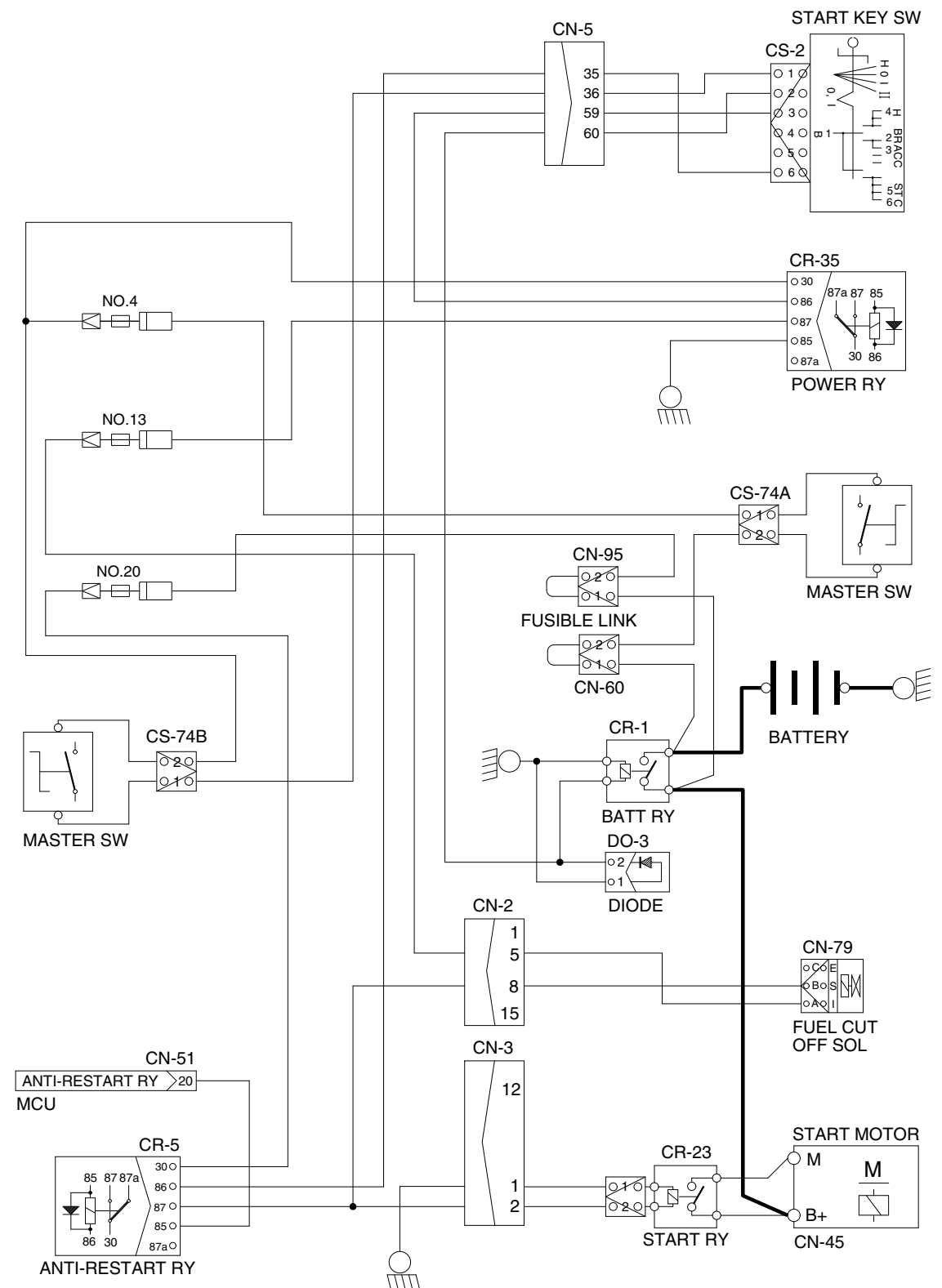
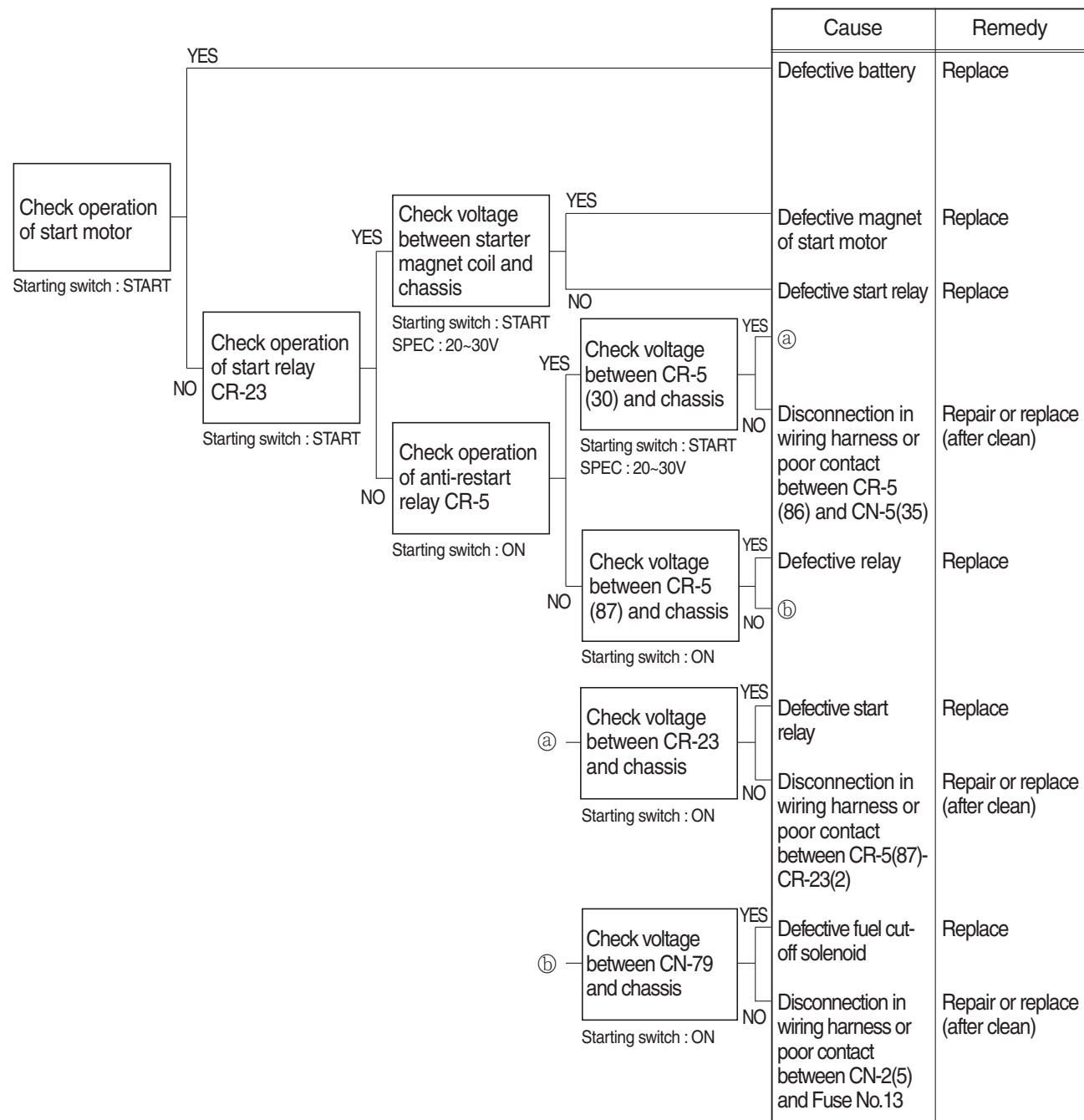

### 13. WHEN STARTING SWITCH ON DOES NOT OPERATE

- Before disconnecting the connector, always turn the starting switch OFF.
- Before carrying out below procedure, check all the related connectors are properly inserted, master switch ON and check open circuit of fusible link (CN-60).
- After checking, insert the disconnected connectors again immediately unless otherwise specified.

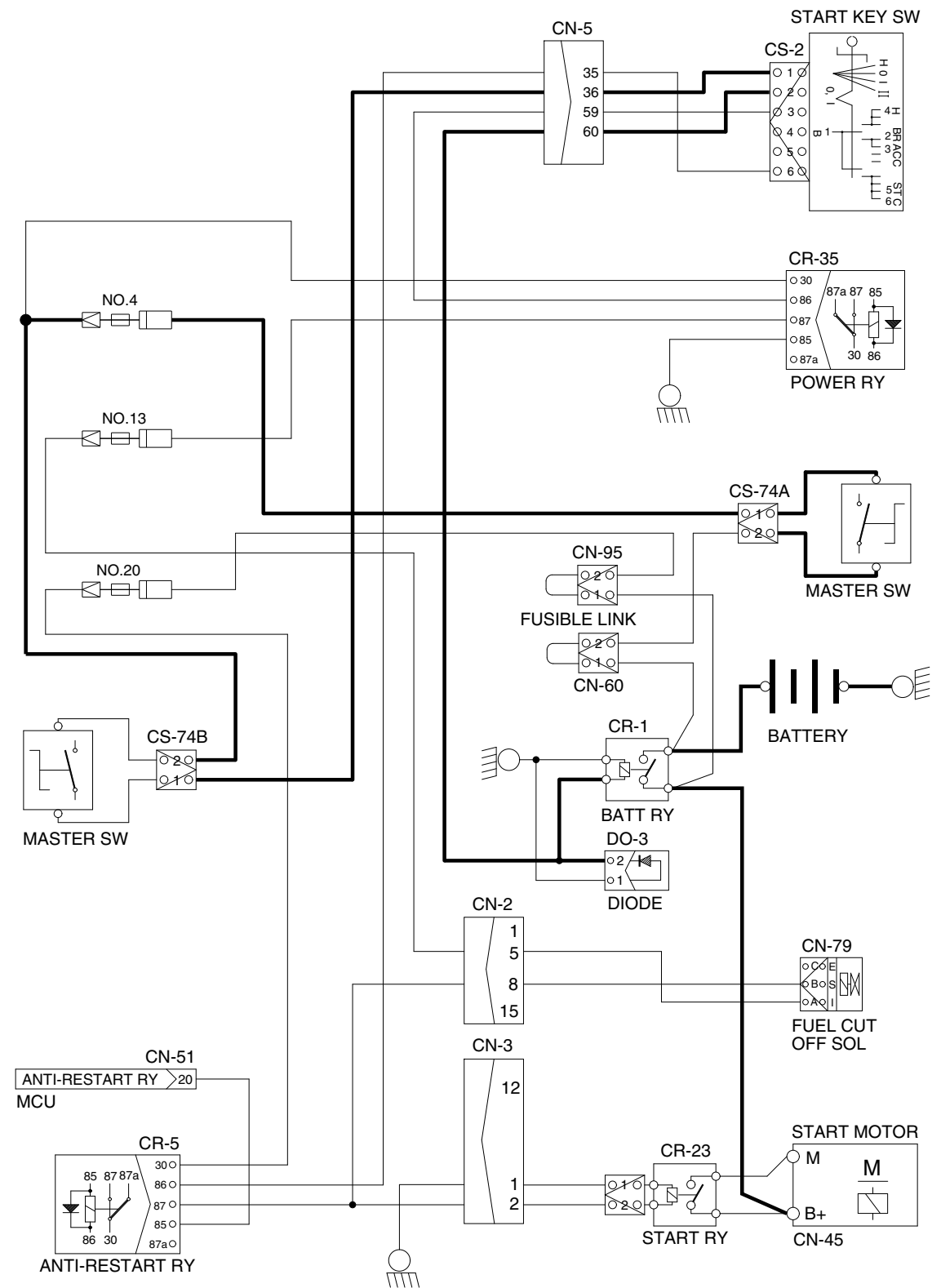
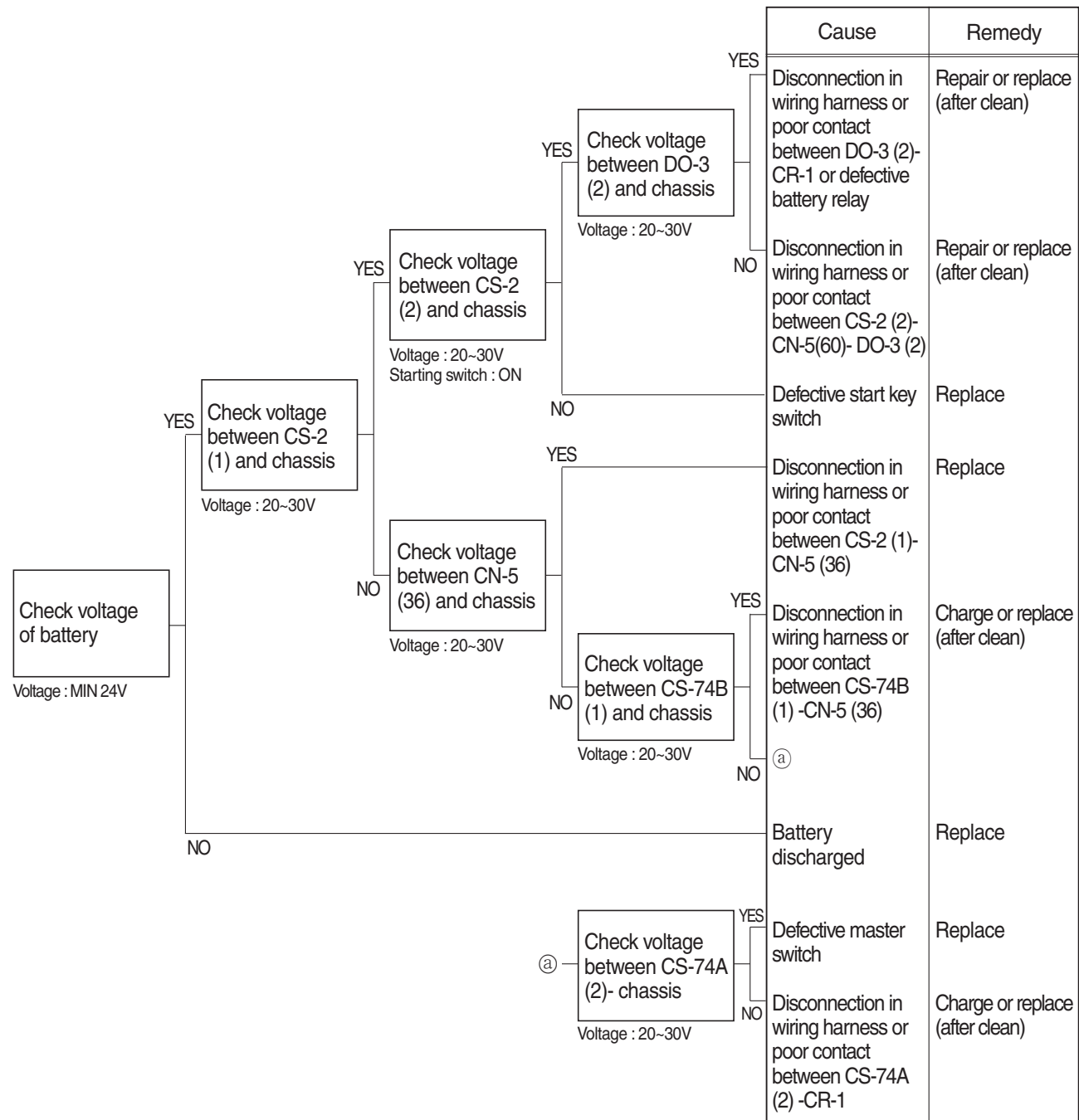

## 14. WHEN STARTING SWITCH IS TURNED ON, WIPER MOTOR DOES NOT OPERATE

- Before disconnecting the connector, always turn the starting switch OFF.
- Before carrying out below procedure, check all the related connectors are properly inserted and fuse No. 6, 11 and 17 burnt out.
- After checking, insert the disconnected connectors again immediately unless otherwise specified.

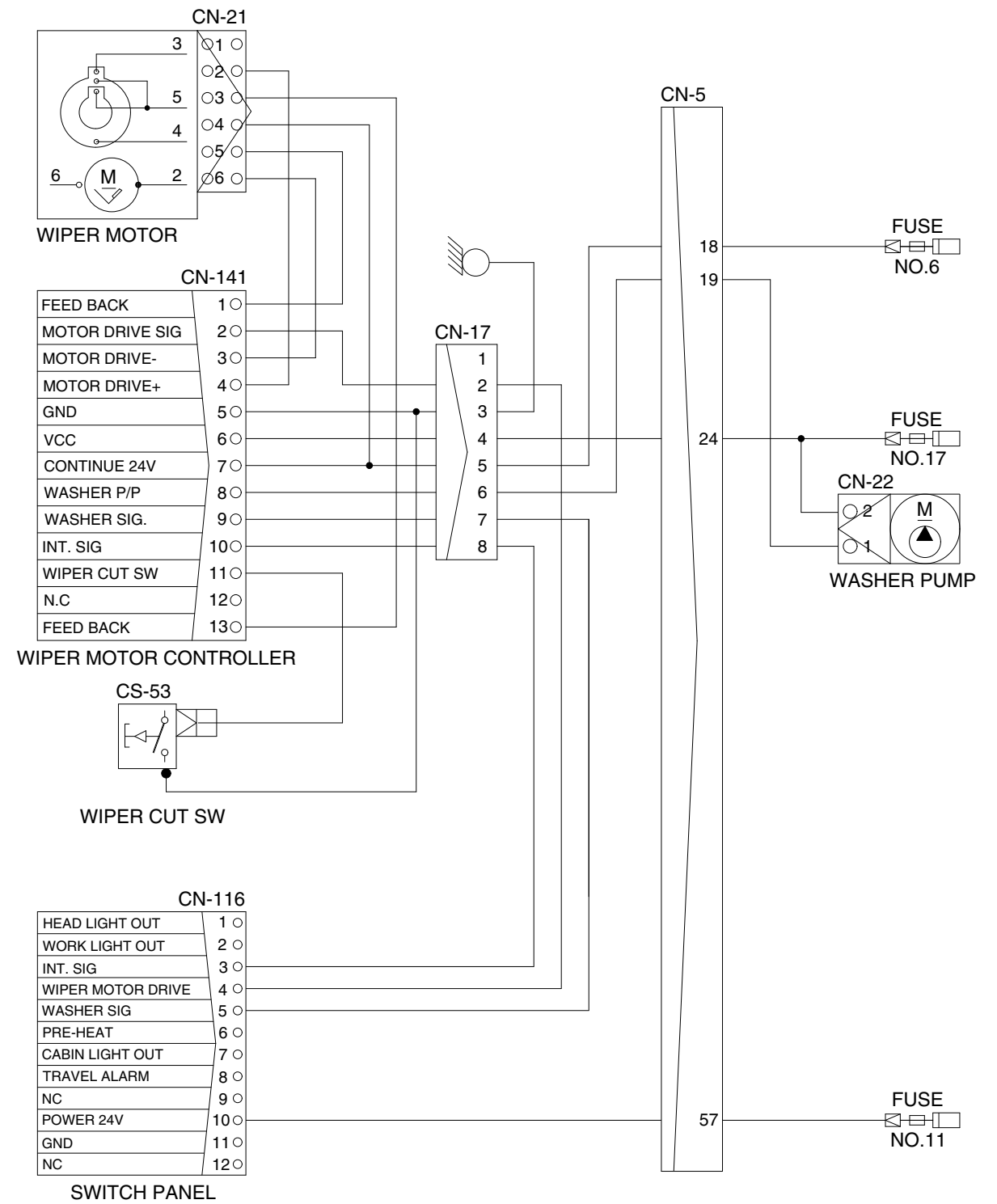
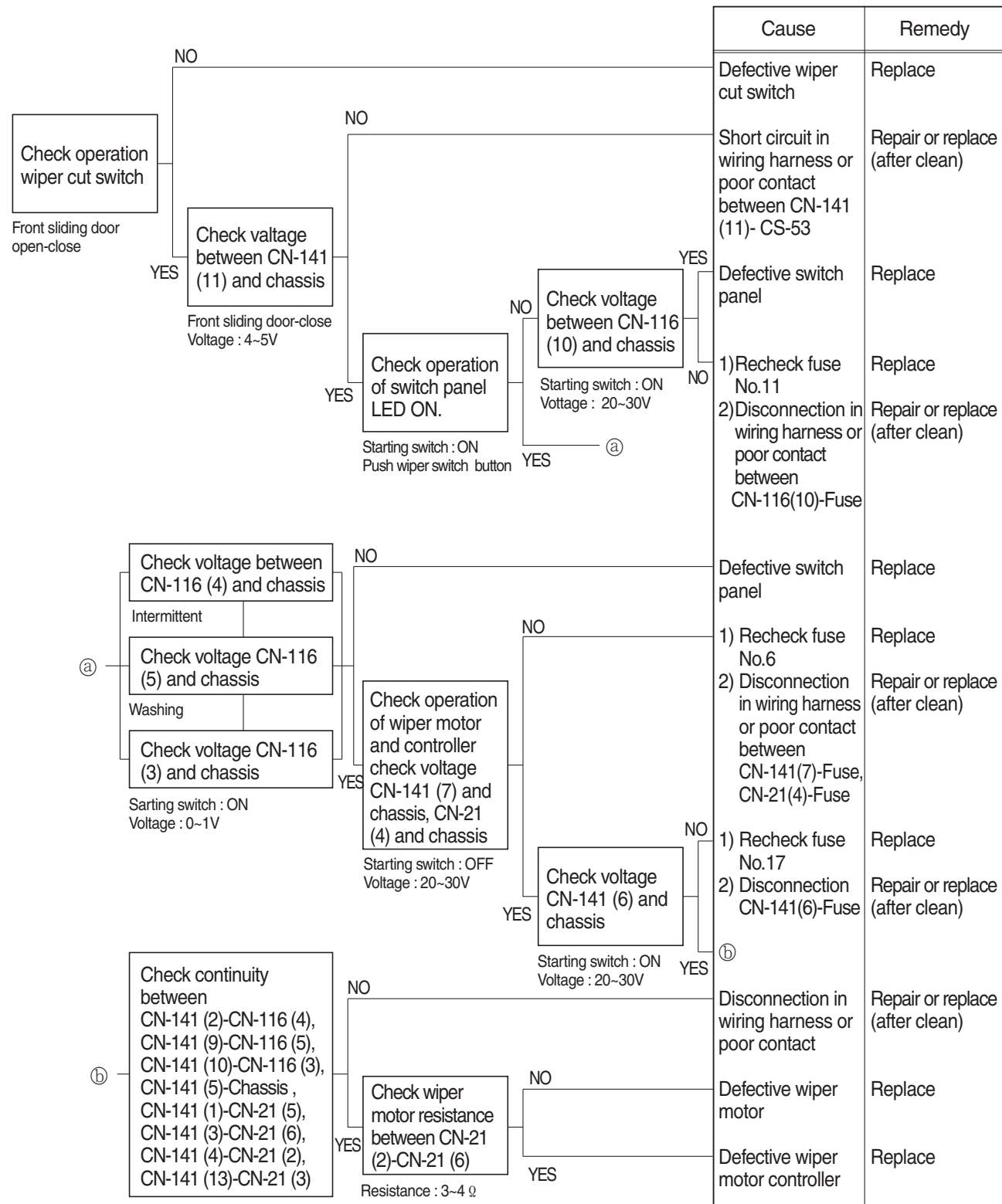

### 15. WHEN STARTING SWITCH IS TURNED ON, HEAD LAMP DOES NOT LIGHTS UP

- Before disconnecting the connector, always turn the starting switch OFF.
- Before carrying out below procedure, check all the related connectors are properly inserted and fuse No.18 burnt out.
- After checking, insert the disconnected connectors again immediately unless otherwise specified.

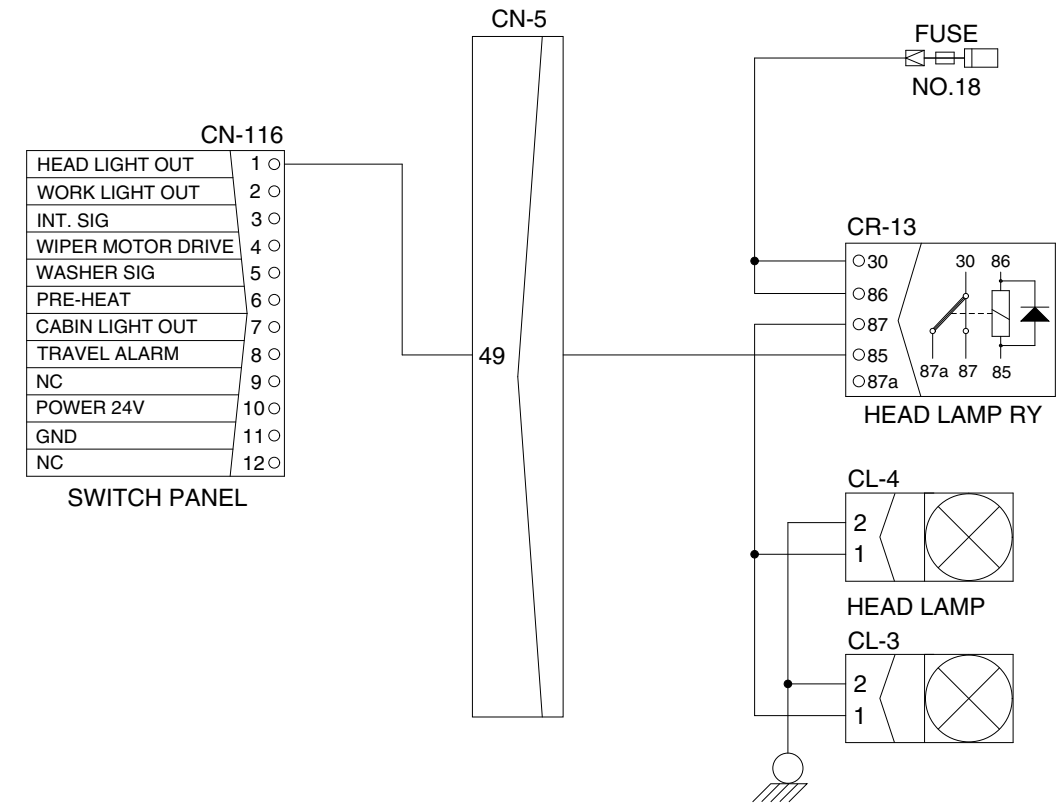
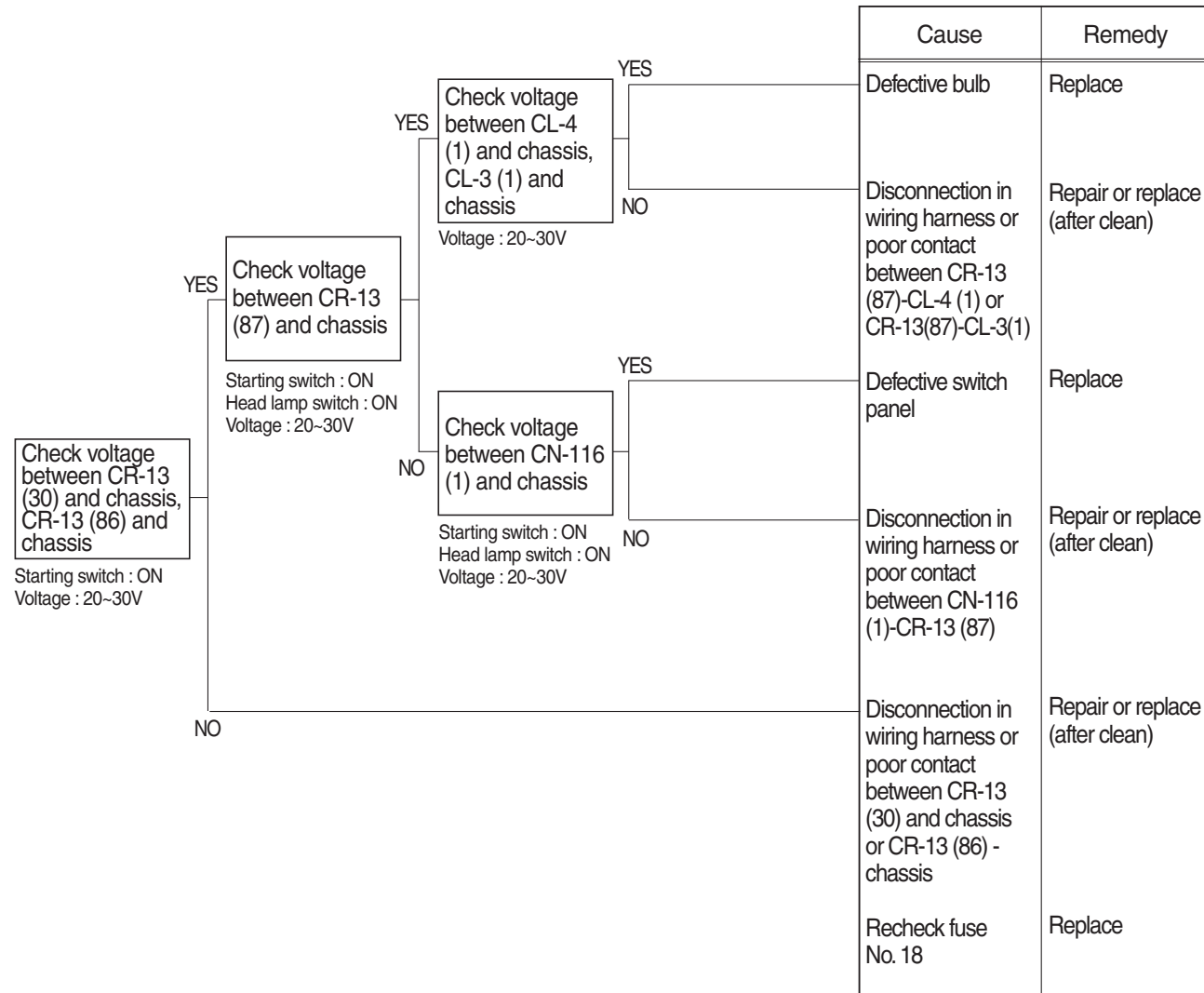

## 16. WHEN STARTING SWITCH IS TURNED ON, WORK LAMP DOES NOT LIGHTS UP

- Before disconnecting the connector, always turn the starting switch OFF.
- Before carrying out below procedure, check all the related connectors are properly inserted and fuse No.15 burnt out.
- After checking, insert the disconnected connectors again immediately unless otherwise specified.

