

GROUP 5 SWING DEVICE (TYPE 2, 3)

1. REMOVAL AND INSTALL OF MOTOR

1) REMOVAL

- (1) Lower the work equipment to the ground and stop the engine.
- (2) Operate the control levers and pedals several times to release the remaining pressure in the hydraulic piping.
- (3) Loosen the breather slowly to release the pressure inside the hydraulic tank.

▲ Escaping fluid under pressure can penetrate the skin causing serious injury.

※ When pipes and hoses are disconnected, the oil inside the piping will flow out, so catch it in oil pan.

- (4) Disconnect hose assembly (2).
- (5) Disconnect pilot line hoses (3, 4, 5, 6, 7, 8).
- (6) Sling the swing motor assembly (1) and remove the swing motor mounting socket bolts (9).

· Motor device weight : 61 kg (135 lb)

- (7) Remove the swing motor assembly.
※ When removing the swing motor assembly, check that all the piping have been disconnected.

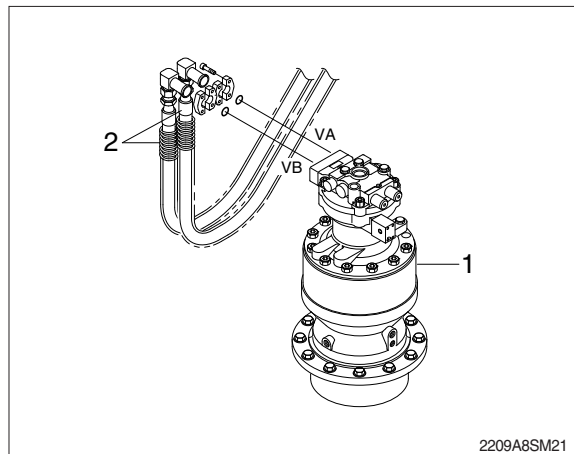

2) INSTALL

- (1) Carry out installation in the reverse order to removal.
- (2) Bleed the air from the swing motor.
 - ① Remove the air vent plug.
 - ② Pour in hydraulic oil until it overflows from the port.
 - ③ Tighten plug lightly.
 - ④ Start the engine, run at low idling and check oil come out from plug.
 - ⑤ Tighten plug fully.
- (3) Confirm the hydraulic oil level and check the hydraulic oil leak or not.

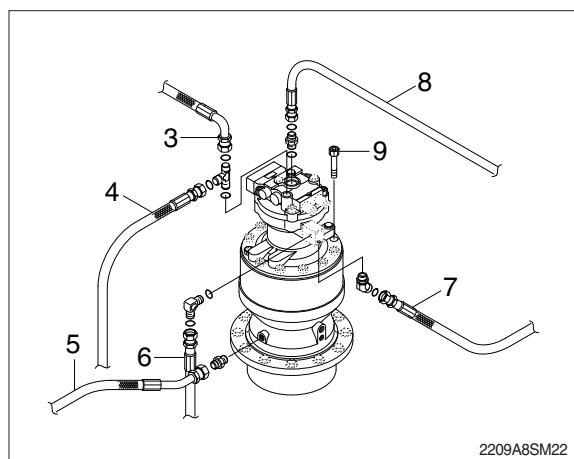

2. DISASSEMBLY AND ASSEMBLY OF SWING MOTOR

1) STRUCTURE

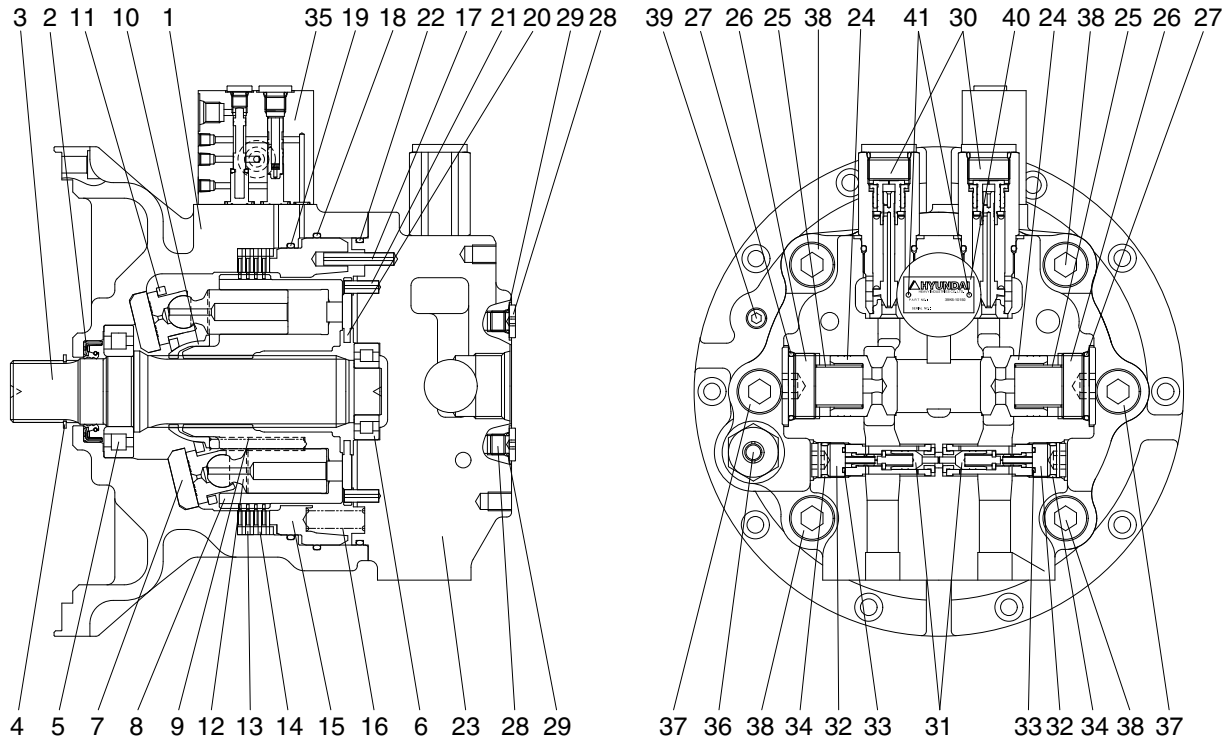

220L2SM02

1	Casing	15	Parking piston	29	O-ring
2	Oil seal	16	Spring	30	Relief valve assy
3	Shaft	17	Spring pin	31	Reactionless valve assy
4	Snap ring	18	O-ring	32	Plug
5	Roller bearing	19	O-ring	33	O-ring
6	Needle bearing	20	Valve plate	34	O-ring
7	Swash plate	21	Spring pin	35	Time delay valve assy
8	Cylinder block	22	O-ring	36	Level gauge
9	Spring	23	Valve casing	37	Socket bolt
10	Ball guide	24	Check valve	38	Socket bolt
11	Retainer plate	25	Spring	39	Plug
12	Piston assy	26	Plug	40	Name plate
13	Friction plate	27	O-ring	41	Rivet
14	Separate plate	28	Plug		

2) DISASSEMBLY

(1) Disassemble drive shaft

- ① Unloosing socket bolt (time delay valve, 42) and disassemble time delay valve assy (35) from casing (1).



2209A8SM51

- ② Disassemble level gauge (36) from casing (1).



2209A8SM52

- ③ Hang valve casing (23) on hoist, unloose socket bolt (37, 38) and disassemble from casing (1).



2209A8SM53

- ④ Disassemble spring (16) and using a jig, disassemble parking piston (15) from casing (1).

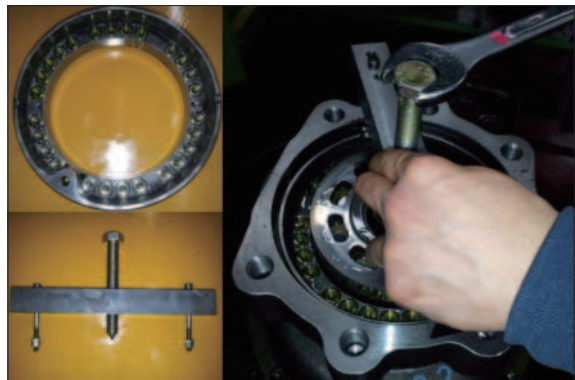

2209A8SM54

- ⑤ Disassemble respectively cylinder block sub (8), friction plate (13), separate plate (14) from casing (1).



2209A8SM55

- ⑥ Disassemble swash plate (7) from casing (1).



2209A8SM56

- ⑦ Using a plier jig, disassemble snap ring (4) from casing (1).

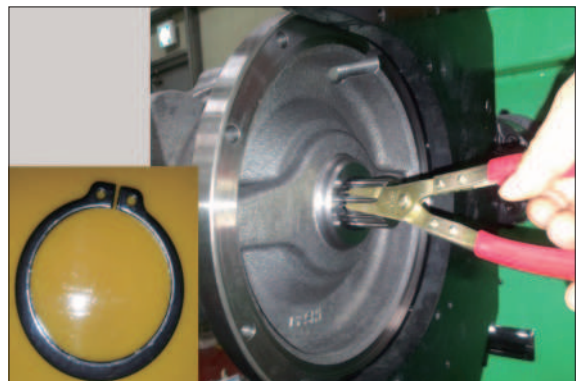

2209A8SM57

- ⑧ Disassemble shaft assy (3), oil seal (2) and O-ring (18, 22) from casing (1).

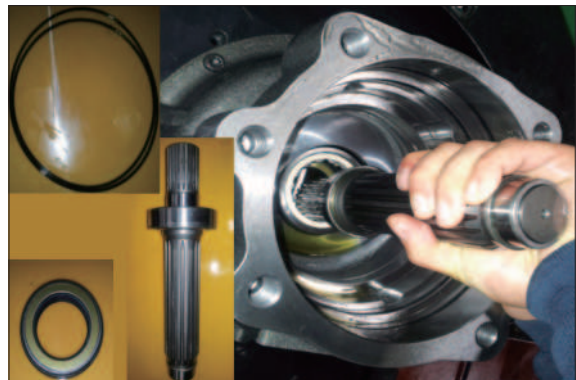

2209A8SM58

(2) Disassemble cylinder block sub

- ① Disassemble piston assy (12) from cylinder block (8).

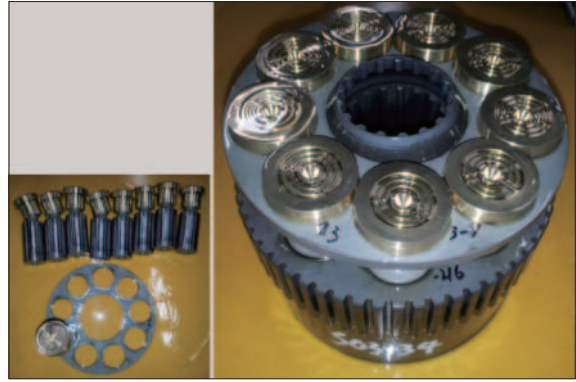

- ② Disassemble ball guide (10) and spring (cylinder block, 9) from cylinder block (8).
 - Ball guide × 1EA
 - Spring × 9EA



(3) Disassemble valve casing sub

- ① Disassemble spring pin (17, 21), valve plate (20), O-ring (22) from valve casing (23).



- ② Using a torque wrench, disassemble relief valve (30) from valve casing (23).



- ③ Using a torque wrench, disassemble plug (32) from valve casing (23) and disassemble O-ring (33, 34) and reaction-less valve assy (31).



2209A8SM63

- ④ Using a torque wrench, disassemble check valve (24) from valve casing (23).

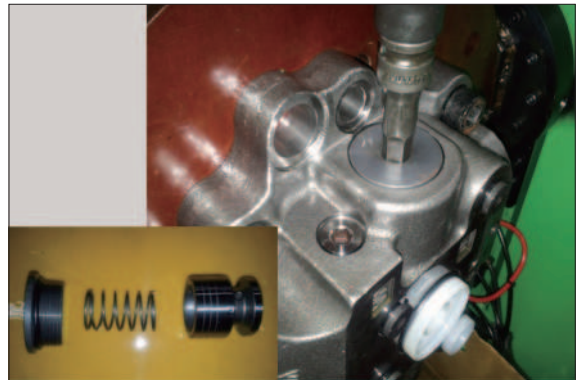

2209A8SM64

- ⑤ Disassemble plug (28), O-ring (29) from valve casing (23).



2209A8SM65

3) ASSEMBLING

(1) Assemble shaft sub

- ① Put roller bearing (3) on preheater and provide heat to inner race.
(Temperature in conveyor : 120°C for 3~5 minutes)

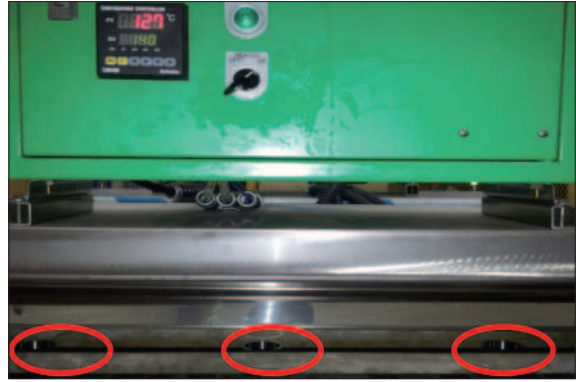

2209A8SM66

- ② Using a robot machine, assemble and press preheated roller bearing (3) into shaft (5).



2209A8SM67

(2) Assemble cylinder block sub

- ① Assemble 9 springs (cylinder block, 9) into cylinder block (8).
 - Spring × 9EA



2209A8SM68

- ② Assemble ball guide (10) into cylinder block (8).
 - Ball guide × 1EA



2209A8SM69

③ Assemble 9 piston assy (12) into retainer plate (11).

- Piston assy × 9EA
- Retainer plate × 1EA

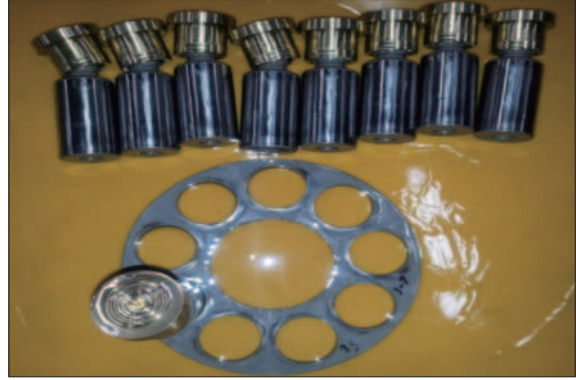

2209A8SM70

④ Assemble parts of procedure ② and ③.

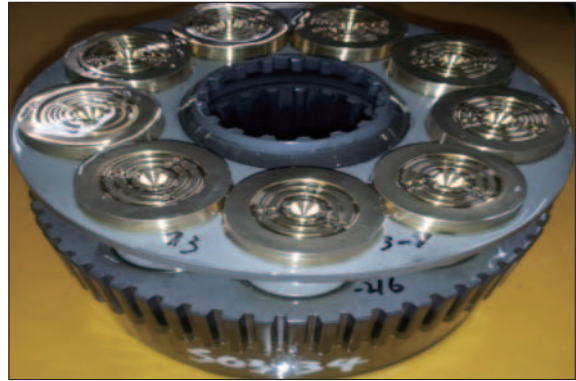

2209A8SM71

(3) Assemble valve casing sub

① Assemble make up check valve sub

Assemble check valve (24), O-ring (27), plug (26) in that order and then screw it torque wrench.

- Make up check valve × 2EA
- Spring × 2EA
- Plug × 2EA
- O-ring × 2EA

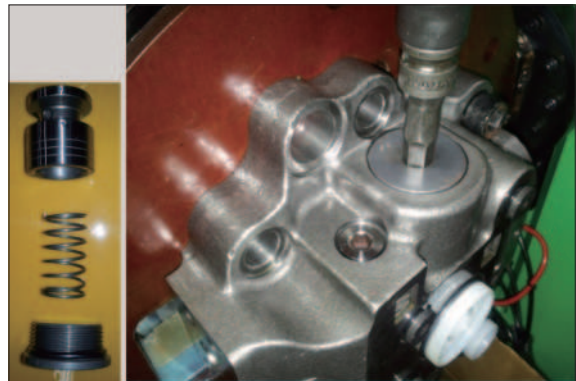

2209A8SM72

② Assemble reactionless valve assy

Assemble reactionless valve assy (31), plug (32), O-ring (33, 34) in that order and then screw it a torque wrench.

- Reactionless valve assy (31) × 2EA
- Plug (32) × 2EA
- O-ring (33, 34) × 2EA

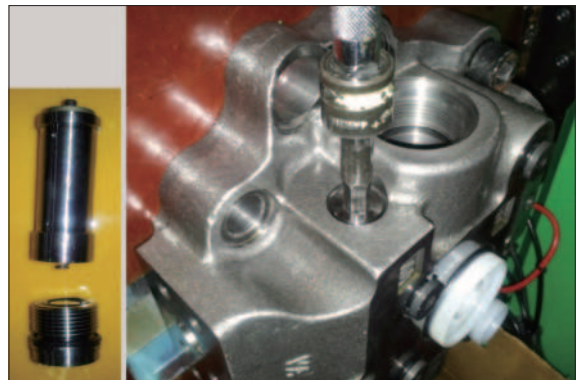

2209A8SM73

- ③ Using a torque wrench, assemble relief valve (30) 2 sets into valve casing (23).
- Relief valve (30) × 2EA



2209A8SM74

- ④ Assemble plug (28) and O-ring (27) into valve casing (23).
- Plug (28) × 3EA
 - O-ring (27) × 3EA



2209A8SM75

- ⑤ Assemble needle bearing (6) into valve casing (23) and assemble spring pin (17, 21) into valve casing (23).
- Needle bearing (6) × 1EA
 - Spring pin (17, 21) × 1EA

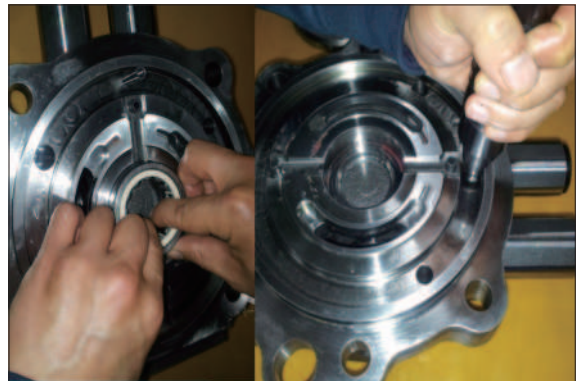

2209A8SM76

- ⑥ Apply some grease valve plate (20) and assemble it into valve casing (23).

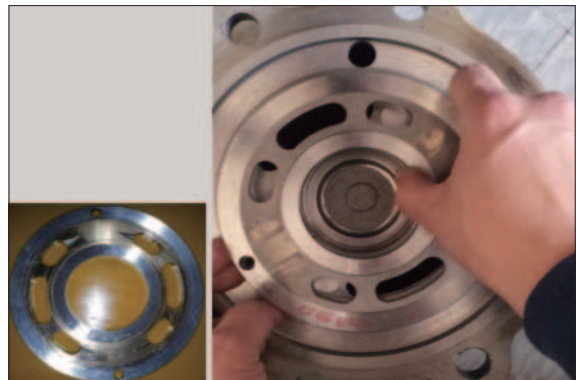

2209A8SM77

(4) Assemble drive shaft sub

- ① Using a jig, assemble oil sealing (2) into casing (1).



2209A8SM78

- ② Fit shaft sub (shaft+roller bearing) into casing (1).



2209A8SM79

- ③ Using a plier jig, assemble snap ring (4) to shaft (3).
 - Snap ring × 1EA



2209A8SM80

- ④ Apply some grease swash plate (7) and assemble it into casing (1).
 - Swash plate × 1EA



2209A8SM81

⑤ Insert O-ring (18, 19) into casing (1).

- O-ring (18) × 1EA
- O-ring (19) × 1EA

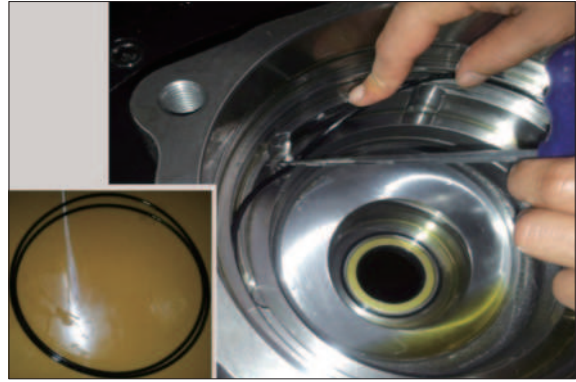

2209A8SM82

⑥ Assemble cylinder block (8) into casing (1).



2209A8SM83

⑦ Assemble separate plate (14) and friction plate (13) 4 sets into casing (1) and fit parking piston (15) into casing (1) by a jig or a press.

- Separate plate × 4EA
- Friction plate × 4EA
- Parking piston × 1EA



2209A8SM84

⑧ Assemble spring (parking piston, 16) into parking piston (15).

- Spring × 26EA

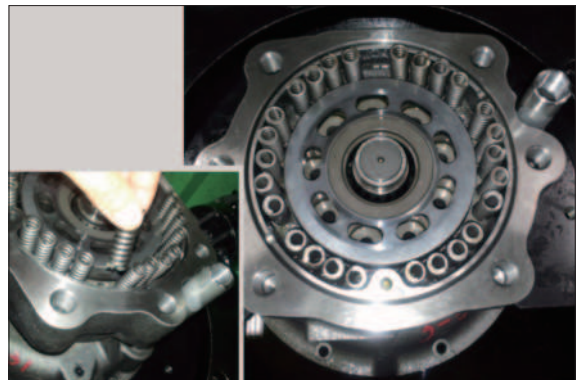

2209A8SM85

- ⑨ Lift up valve casing (23) on casing (1) by a crane and assemble it with socket bolts (37, 38).



2209A8SM86

- ⑩ Assemble level gauge (36) and plug (39) into casing (1).



2209A8SM87

- ⑪ Assemble time delay valve assy (35) into valve casing (23) with socket bolt (42).
- Time delay valve × 1EA
 - Socket bolt × 3EA



2209A8SM88

⑫ **Air pressing test**

Be sure of leakage, after press air into assembled motor and put it in water for 1 minute (pressure : 2 kgf/cm²).



2209A8SM89

⑬ **Leakage check**

Place motor on a bench tester and after cleaning motor by color check No.1, paint No.3 and be sure of leakage.



2209A8SM90

⑭ **Mount test bench**

Mounting motor a test bench, test the availability of each part.

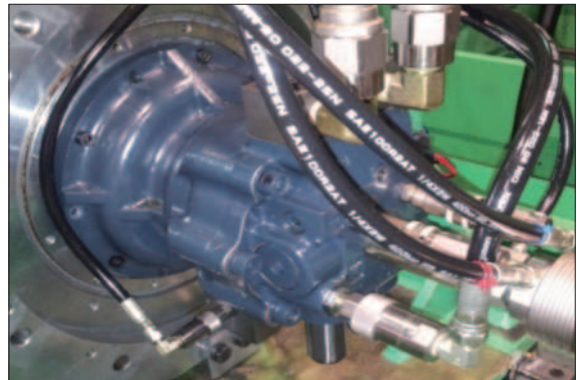

2209A8SM91

3. DISASSEMBLY AND ASSEMBLY OF REDUCTION GEAR

1) STRUCTURE

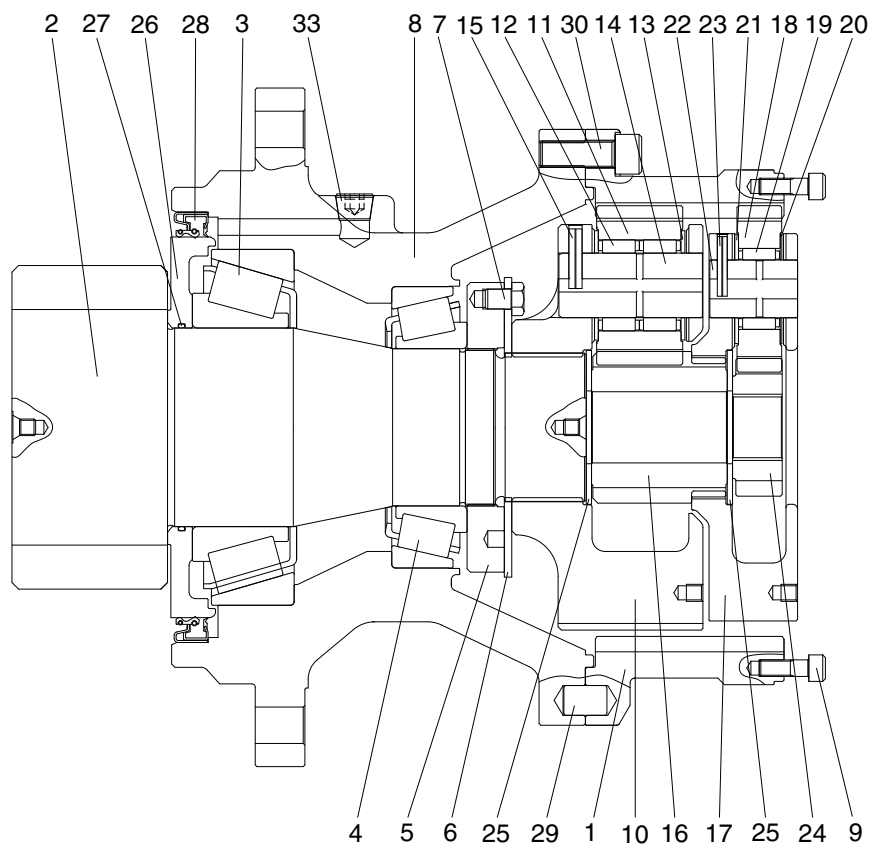

220L2SM03

- | | | | | | |
|----|---------------|----|------------------|----|-----------------|
| 1 | Ring gear | 11 | Planetary gear 2 | 21 | Thrust washer 1 |
| 2 | Drive shaft | 12 | Needle bearing 2 | 22 | Carrier pin 1 |
| 3 | Taper bearing | 13 | Thrust washer 2 | 23 | Spring pin 1 |
| 4 | Taper bearing | 14 | Carrier pin 2 | 24 | Sun gear 1 |
| 5 | Ring nut | 15 | Spring pin 2 | 25 | Thrust plate |
| 6 | Lock plate | 16 | Sun gear 2 | 26 | Sleeve |
| 7 | Hexagon bolt | 17 | Carrier 1 | 27 | O-ring |
| 8 | Casing | 18 | Planetary gear 1 | 29 | Parallel pin |
| 9 | Socket bolt | 19 | Needle bearing 1 | 30 | Socket bolt |
| 10 | Carrier 2 | 20 | Thrust washer 1 | 33 | Plug |

2) DISASSEMBLY

(1) Preparation

- ① The reduction gear removed from machine is usually covered with mud.
Wash out side of reduction gear and dry it.
 - ② Setting reduction gear on work stand for disassembling.
 - ③ Mark for mating
Put marks on each mating parts when disassembling so as to reassemble correctly as before.
- ▲ Take great care not to pinch your hand between parts while disassembling not let fall parts on your foot while lifting them.

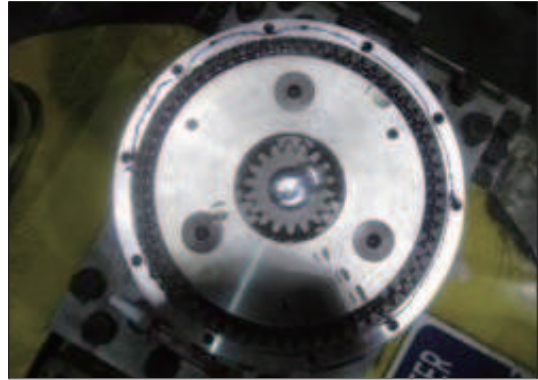

2209A8SM01

(2) Disassembly

- ① Remove every "Socket bolt (M10)" that secure swing motor and reduction gear.
- ② Removing carrier sub assy & sun gear
 - a. Removing No.1 sun gear from No.1 carrier sub assy.
※ Be sure maintaining it vertical with ground when disassembling No.1 sun gear.



2209A8SM02

- b. Removing No.1 carrier sub assy screwing I-bolt to tab hole (M10) in No.1 carrier.
Lifting it gradually maintaining it vertical with ground.
※ It's impossible to disassemble No.1 spring pin. If No.1 spring pin has problem, change whole No.1 carrier sub assy.



2209A8SM03

c. Removing No.2 sun gear from No.2 carrier sub assy.

※ Be sure maintaining it vertical with ground when disassembling No.2 sun gear.



2209A8SM04

d. Removing No.2 carrier sub assy screwing I-bolt to tab hole (M10) in No.2 carrier. Lifting it gradually maintaining it vertical with ground.

※ It's impossible to disassemble No.2 spring pin. If No.2 spring pin has problem, change whole No.2 carrier sub assy.



2209A8SM05

③ Removing ring gear

After unscrewing every socket bolt (M16), remove ring gear from casing.

※ Because of liquid gaskets between ring gear and casing, put sharp punch between ring gear and casing and tapping it to remove them.



2209A8SM06

④ Removing drive shaft sub assy

- a. Unscrew every hex head bolt (M12) to remove lock plate.

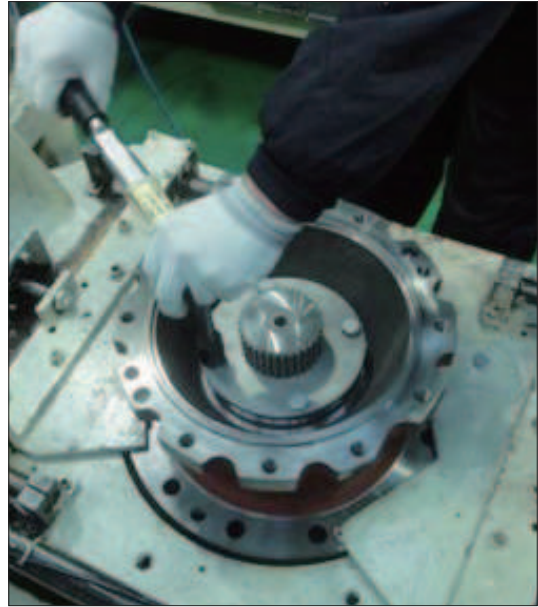

2209A8SM07

- b. Rolling ring nut for removing them from drive shaft sub assy.

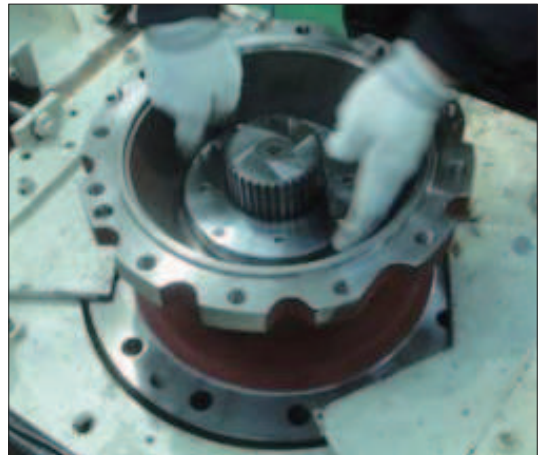

2209A8SM08

- ※ Use special tool to roll ring nut to counter clockwise.

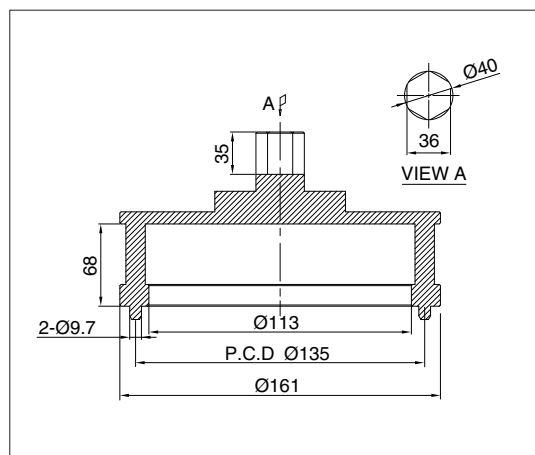

220L8SM01

- c. Remove drive shaft sub assy from casing.
※ Set a rack for flange of casing, and remove drive shaft sub assy from casing by using press.



2209A8SM09

- d. Remove oil seal & taper bearing (small) from casing.
※ Do not re-use oil seal. It is impossible to disassemble drive shaft sub assy.



2209A8SM10



2209A8SM11

4. ASSEMBLY REDUCTION UNIT

1) GENERAL NOTES

- (1) Clean every part by kerosene and dry them in a cool and dry place.
- (2) Loctite on surface must be removed by solvent.
- (3) Check every part for any abnormal.
- (4) Each hexagon socket head bolt should be used with loctite #242 applied on its threads.
- (5) Apply gear oil slightly on each part before assembling.

▲ Take great care not to pinch your hand between parts or tools while assembling nor let fall parts on your foot while lifting them.

Inspection before assembling.

Thrust washer

- Check the seizure, abnormal wear or uneven wear.
- Check the unallowable wear.

Gear

- Check the pitting or seizure on tooth surface.
- Check the cracks on the root of tooth.

Bearing

- Rotate it by hands to check such noise or uneven rotation.

2) ASSEMBLING NO.1 CARRIER SUB ASSY

- (1) Put thrust plate firmly in No.1 carrier.
- (2) After assembling No.1 needle bearing to No.1 planetary gear, put a pair of No.1 thrust washer on both sides of bearing and install them to No.1 carrier.



2209A8SM12



2209A8SM13

- (3) Make of spring pin hole No.1 pin and No.1 carrier of spring pin hole in line, press No.1 spring pin into the holes.
 Make No.1 spring pin hole head for No.1 planetary gear.



2209A8SM14

- (4) Caulk carrier holes to make No.1 spring pin settle down stably.



2209A8SM15

- ※ Refer to “Caulking details”
 Use paint marker for marking after caulking.

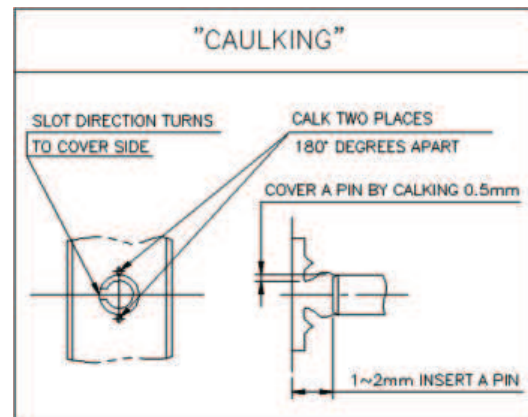

2209A8SM16

2) ASSEMBLING NO.2 CARRIER SUB ASSY

(1) Put thrust plate in firmly No.2 carrier.



2209A8SM17

(2) After assembling No.2 needle bearing to No.2 planetary gear, put 2 pieces of No.2 thrust washer on both sides of bearing and install them to No.2 carrier.



2209A8SM18

(3) Align No.2 spring pin hole and No.2 carrier spring pin hole, put No.2 spring pin into the holes.
Make No.2 spring pin cutting line face to No.2 planetary gear.

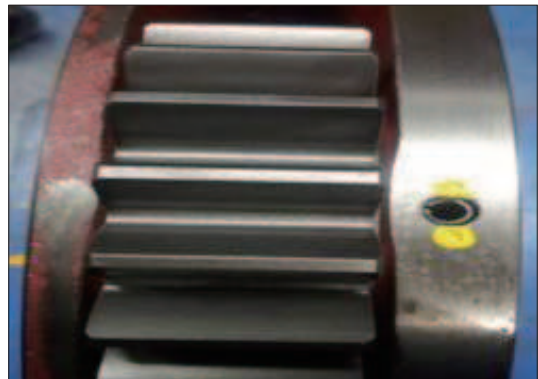

2209A8SM19

(4) Caulk carrier holes to make No.2 spring pin settle down stably.

※ Refer to "Caulking details"

Use paint marker for marking after caulking.

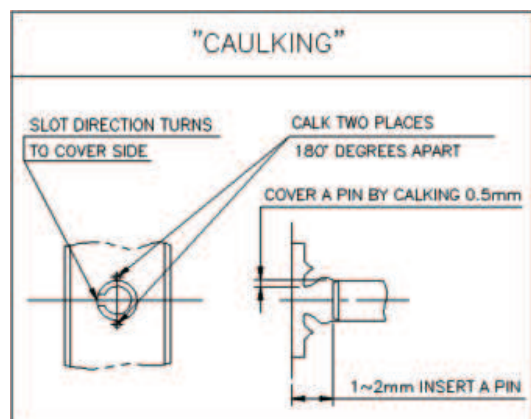

2209A8SM20

3) ASSEMBLING PINION GEAR SUB ASSY

- (1) Prepare drive shaft pinion gear vertical with ground.



2209A8SM21

- (2) Fully apply grease (albania EP02) to O-ring groove of sleeve.
※ Be sure to maintain it vertical with ground when assembling it.
- (3) Put O-ring into O-ring groove of sleeve.
Fully apply grease on O-ring.

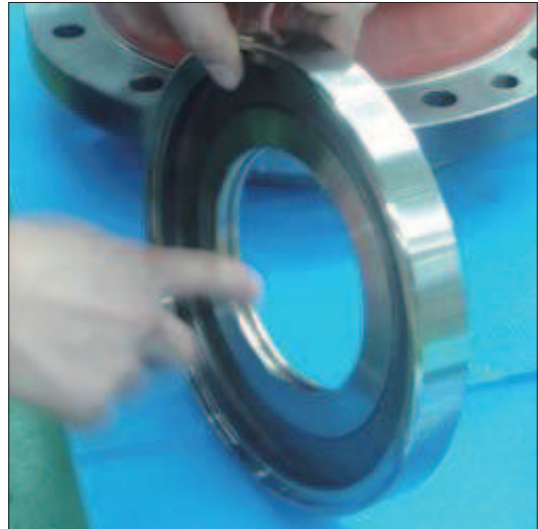

2209A8SM22

- (4) Assemble taper bearing and sleeve into drive shaft using press jig.
Use special jig for pressing. Leave no space between sleeve and taper bearing.

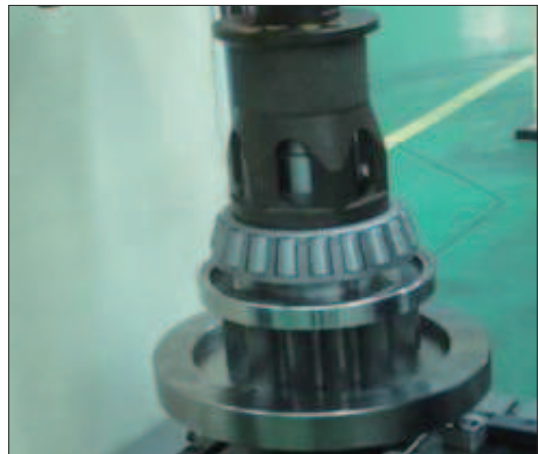

2209A8SM23



2209A8SM24

4) ASSEMBLING BEARING CUP & OIL SEAL (PRESSING)

- (1) Put top, bottom bearing cup into casing.
Use special jig for pressing. Pay attention to foreign materials while assembling bearing cup.
- ※ Flip over casing to assemble oil seal.

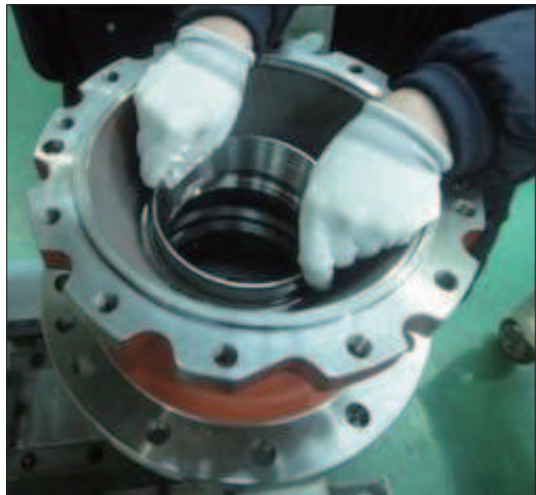

2209A8SM25



2209A8SM26

- (2) Assemble oil seal to casing.
Use special jig for pressing. Pay attention to direction of dust seal and dent.

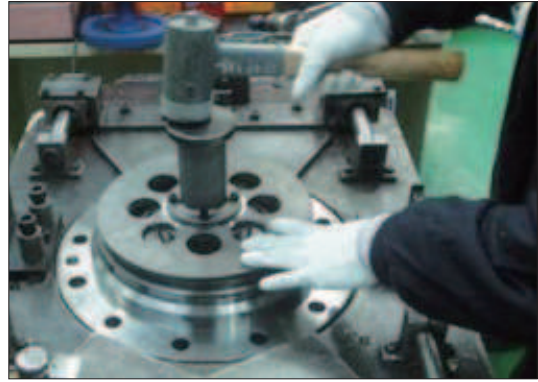

2209A8SM27

※ WHILE ASSEMBLING OIL SEAL

1. Be sure to set dust seal to gear oil.
2. Before assembling, charge enough grease in oil seal.
3. Before assembling, apply enough grease inside and outside of oil seal.

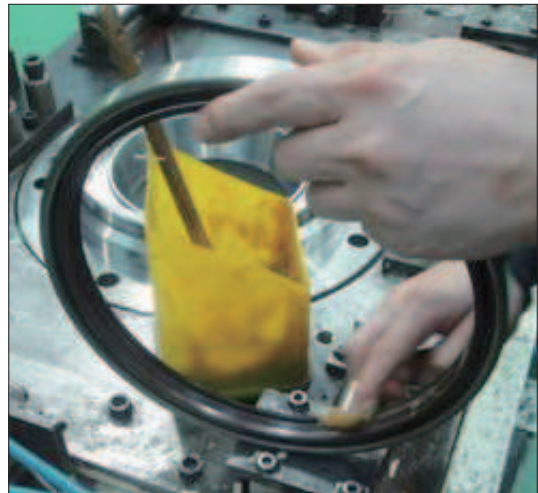

2209A8SM28

5) ASSEMBLING SHAFT SUB ASSY & RING NUT

- (1) After assembling casing & drive shaft sub
assy, flip it over.

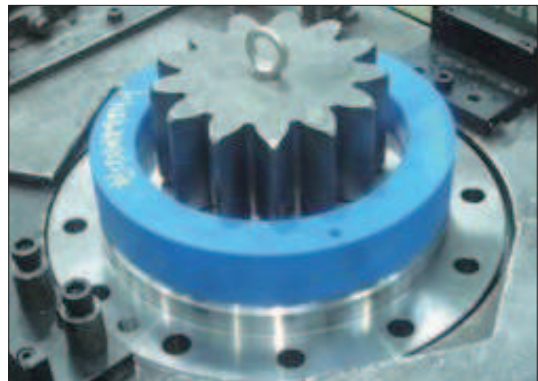

2209A8SM29

- (2) Put drive shaft sub assy into casing.
※ Be sure to maintain it vertical with ground when assembling it.



2209A8SM30

- (3) Put taper bearing into it.
Rotate bearing by hands for checking after assembly.

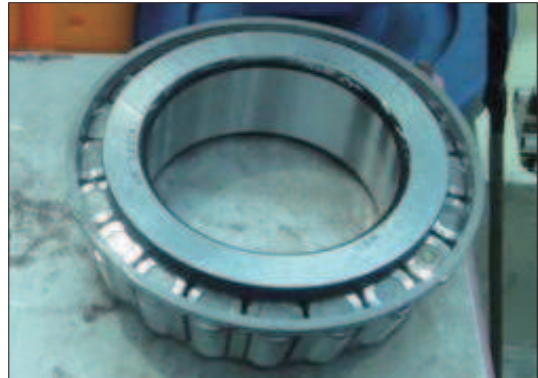

2209A8SM31

- (4) Put ring nut into drive shaft sub assy by using special jig.

The tightening torque (M95) = 3.5 ± 0.4 kgf·m
(25.3 ± 2.9 lbf·ft)



2209A8SM32

- ※ Apply enough loctite #242 before screwing bolts.

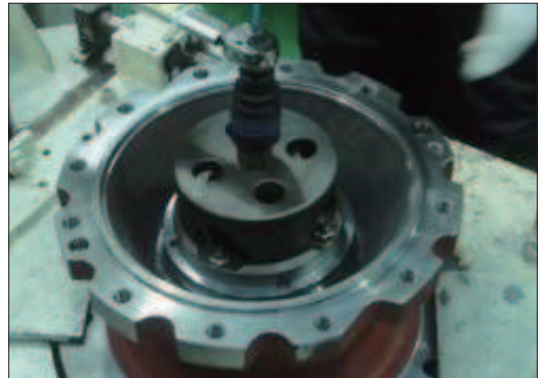

2209A8SM33

- (5) Align bolt screw of ring nut with lock plate's hole.

In case of misalign between bolt screw ring nut and lock plate's hole, put lock plate as near as possible to hole of bolt screw of ring nut and make it in line by increasing tightening torque.



2209A8SM34



2209A8SM35

- (6) Screw 4 bolts (M12×16) to connect ring nut and lock plate by using torque wrench.

Bolt (M12, 4EA) = 10.9T

The tightening torque = 8.8 ± 0.9 kgf·m
(63.7 ± 6.5 lbf·ft)

- ※ Apply enough loctite #242 before screwing bolts.



2209A8SM36

- (7) Use paint marker for checking surplus parts after assembling.



2209A8SM37

6) ASSEMBLING RING GEAR

- (1) Apply loctite #515 bottom of casing sub assy contacting with ring gear without disconnection.

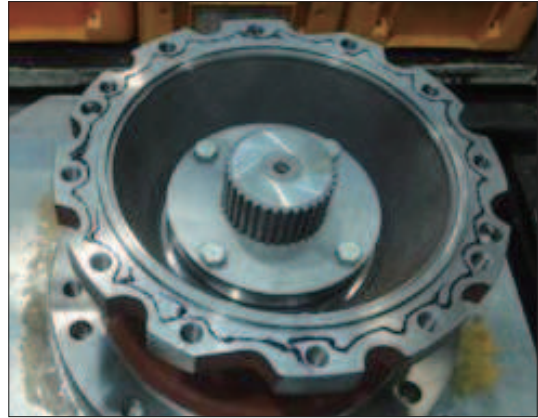

2209A8SM38

Refer to loctite detail.

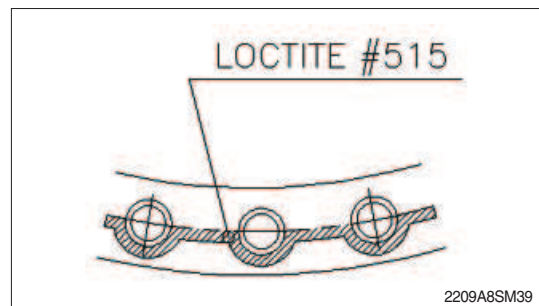

2209A8SM39

- (2) Put parallel pin into hole of casing sub assy.
Mark parallel pin position using paint marker.



2209A8SM40

- (3) Align ring gear with parallel pin to put them into casing sub assy.
※ Be sure to maintain them vertical with ground while using press.

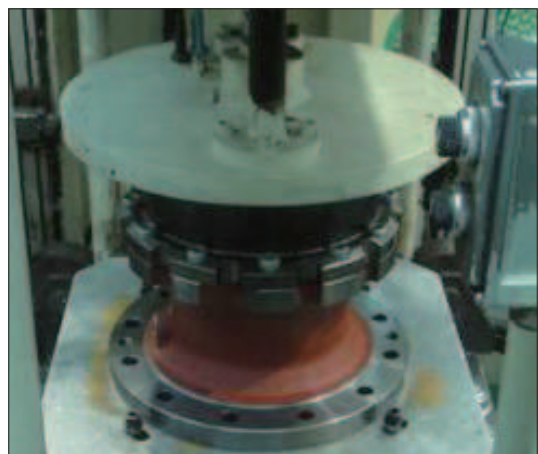

2209A8SM41

- (4) Screw 12 bolts (M16×45) to connect casing sub assy and ring gear (01) by using torque wrench.

Bolt (M16, 12EA) = 12.9T

The tightening torque = 27 ± 2.7 kgf·m
(195 ± 19.5 lbf·ft)

- ※ Apply enough loctite #242 before screwing bolts.

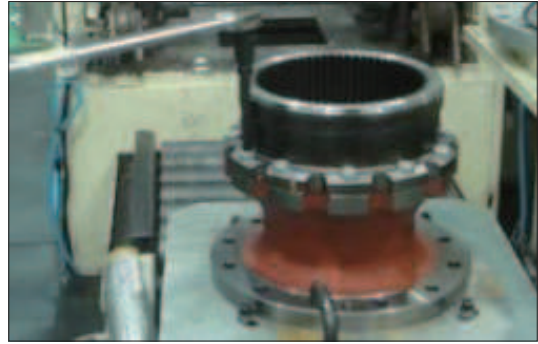

2209A8SM42

- (5) Use paint marker for checking surplus parts after assembling.



2209A8SM43



2209A8SM44

7) ASSEMBLING CARRIER SUB ASSY & SUN GEAR

- (1) Put No.2 carrier sub assy along spline of drive shaft spline.
- Screw M10 I-bolt to No.2 carrier sub assy.
 - Lifting up No.2 carrier sub assy and align planetary gear and tooth of ring gear by rotating planetary gear by hands.
 - Rotate No.2 carrier sub assy by hands to fit No.2 carrier sub assy into drive shaft spline.



2209A8SM45

- (2) Put No.2 sun gear into No.2 carrier sub assy.



2209A8SM46

- (3) Put No.1 carrier sub assy into No.2 sun gear along spline.
- Screw M10 I-bolt to No.1 carrier sub assy.
 - Lifting up No.1 carrier sub assy and align planetary gear and tooth of ring gear by rotating planetary gear by hands.
 - Rotate No.1 carrier sub assy by hands to fit No.1 carrier into No.2 sun gear spline.



2209A8SM47

- (4) Put No.1 sun gear into No.1 carrier sub assy. Be sure to maintain it vertical with ground. And align with No.1 planetary gear spline.
- (5) Rotate No.1 carrier sub assy by hands to check noise.

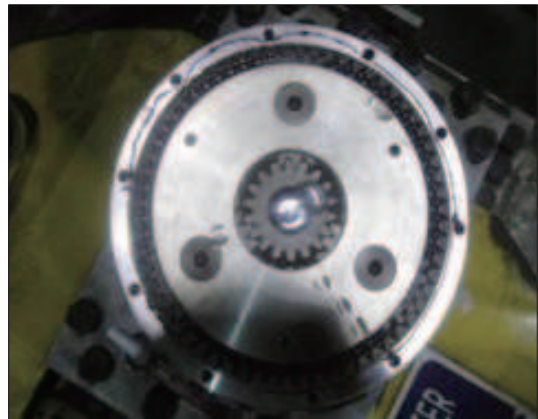

2209A8SM48

8) MEASURING CLEARANCE & ASSEMBLING NAME PLATE

- (1) Check the clearance between ring gear and No.1 sun gear using a tool with dial gauge.
- Check the clearance
Dial gauge = -0.3 ~ +2.95

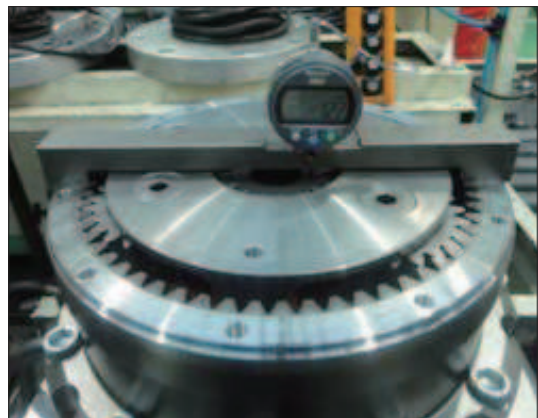

2209A8SM49