

GROUP 2 MODE SELECTION SYSTEM (CLUSTER TYPE 1)

1. POWER MODE SELECTION SYSTEM

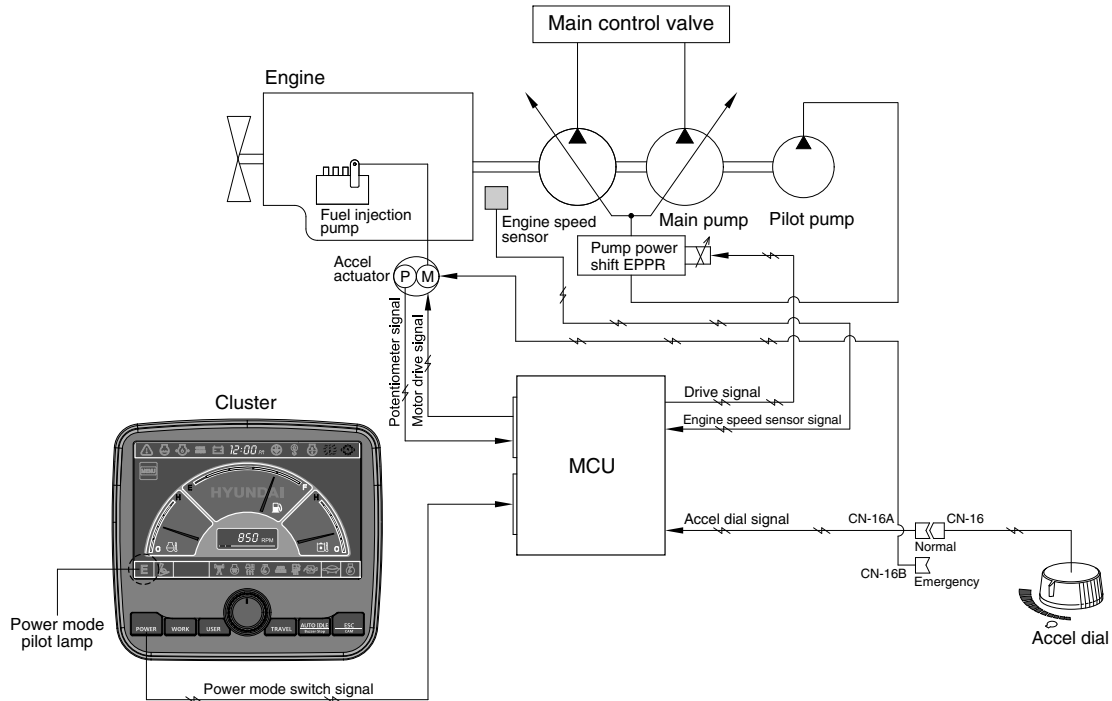

1409S5MS02

Mode selection system (micro computer based electro-hydraulic pump and engine mutual control system) optimizes the engine and pump performance.

The combination of 3 power modes (P, S, E) and accel dial position (10 set) makes it possible to use the engine and pump power more effectively corresponding to the work conditions from a heavy and great power requesting work to a light and precise work.

Power mode	Application	Engine rpm				Power shift by EPPR valve			
		Standard		Option		Standard		Option	
		Unload	Load	Unload	Load	Current (mA)	Pressure (kgf/cm ²)	Current (mA)	Pressure (kgf/cm ²)
P	Heavy duty power	2100 ± 50	1900 ± 50	2200 ± 50	2000 ± 50	365 ± 30	13	360 ± 30	12
S	Standard power	2000 ± 50	1800 ± 50	2050 ± 50	1850 ± 50	400 ± 30	15 ± 3	365 ± 30	13 ± 3
E	Economy operation	1900 ± 50	1700 ± 50	1950 ± 50	1750 ± 50	400 ± 30	15 ± 3	365 ± 30	13 ± 3
AUTO DECEL	Engine deceleration	1150 ± 100	-	1150 ± 100	-	700 ± 30	38 ± 3	700 ± 30	38 ± 3
One touch decel	Engine quick deceleration	1000 ± 100	-	1000 ± 100	-	700 ± 30	38 ± 3	700 ± 30	38 ± 3
KEY START	Key switch start position	1000 ± 100	-	1000 ± 100	-	700 ± 30	38 ± 3	700 ± 30	38 ± 3

※ Power shift (Standard/Option) can be changed by "Service menu" in "Management" on the cluster.

2. WORK MODE SELECTION SYSTEM

Work mode consists of the general operation (bucket) and the optional attachment (breaker, crusher).

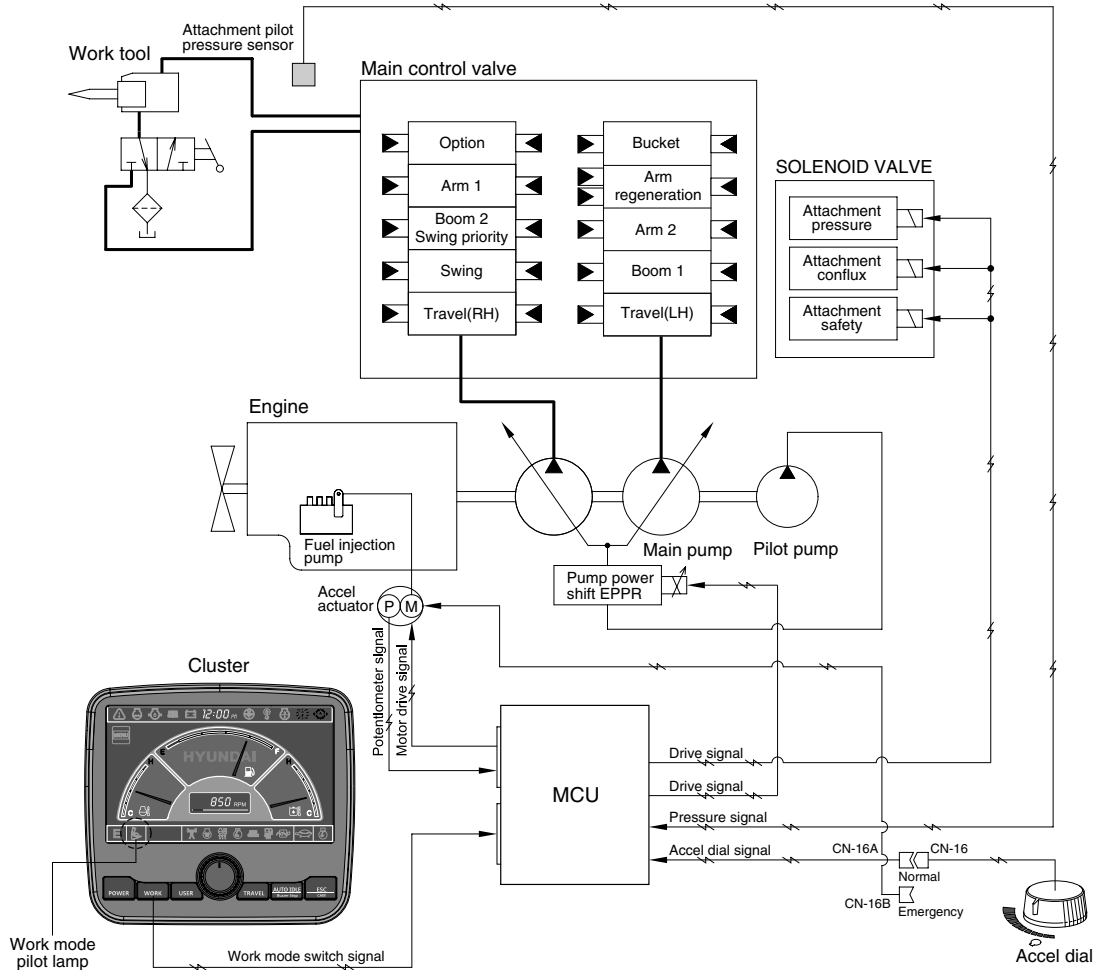

2209S5MS03

1) GENERAL WORK MODE (bucket)

This mode is used to general digging work.

2) ATT WORK MODE (breaker, crusher)

It controls the pump flow and system pressure according to the operation of breaker or crusher.

Description	General mode	Work tool	
	Bucket	Breaker	Crusher
Attachment safety solenoid	OFF	ON	ON
Attachment pressure solenoid	OFF	OFF	ON
Attachment conflux solenoid	OFF	OFF	ON/OFF
Attachment flow EPPR current	100 mA	100~700 mA	100~700 mA

3. USER MODE SELECTION SYSTEM

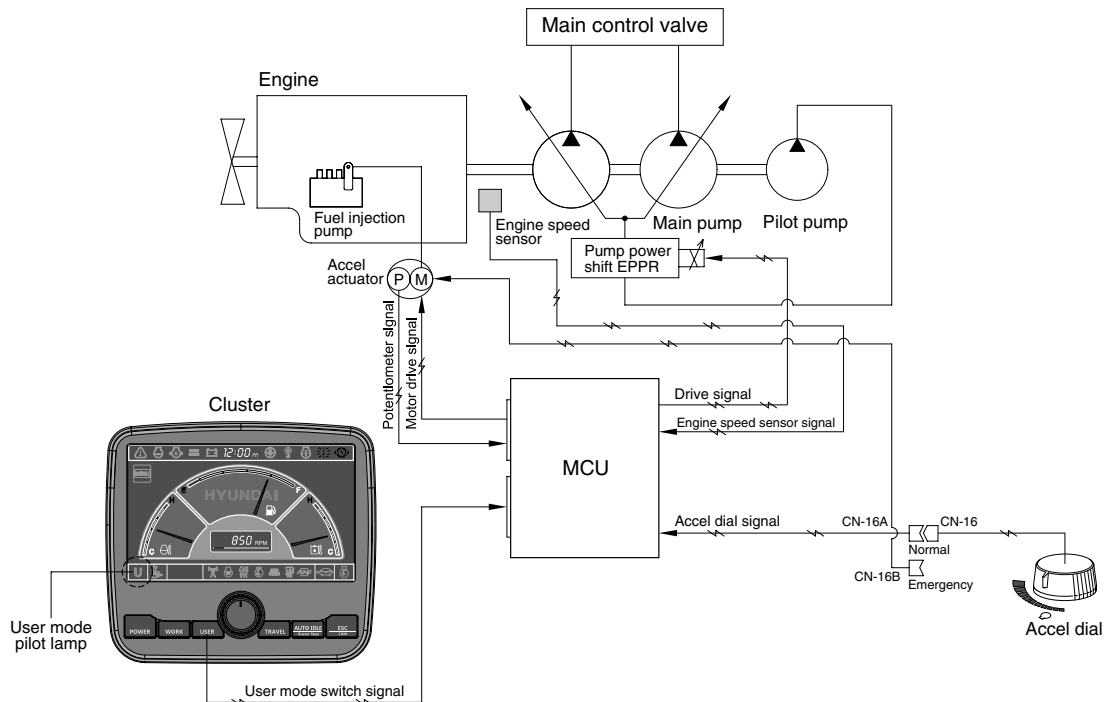

1409S5MS04

1) High idle rpm, auto idle rpm and EPPR pressure can be adjusted and memorized in the U-mode.

2) LCD segment vs parameter setting

Step ()	Engine speed (rpm)	Idle speed (rpm)	Power shift (bar)
1	1500	1000 (low idle)	0
2	1600	1050	3
3	1700	1100	6
4	1800	1150 (decel rpm)	9
5	1900	1200	12
6	2000	1250	16
7	2050	1300	20
8	2100	1350	26
9	2150	1400	32
10	2200	1450	38

MODE SELECTION SYSTEM (CLUSTER TYPE 2)

1. POWER MODE SELECTION SYSTEM

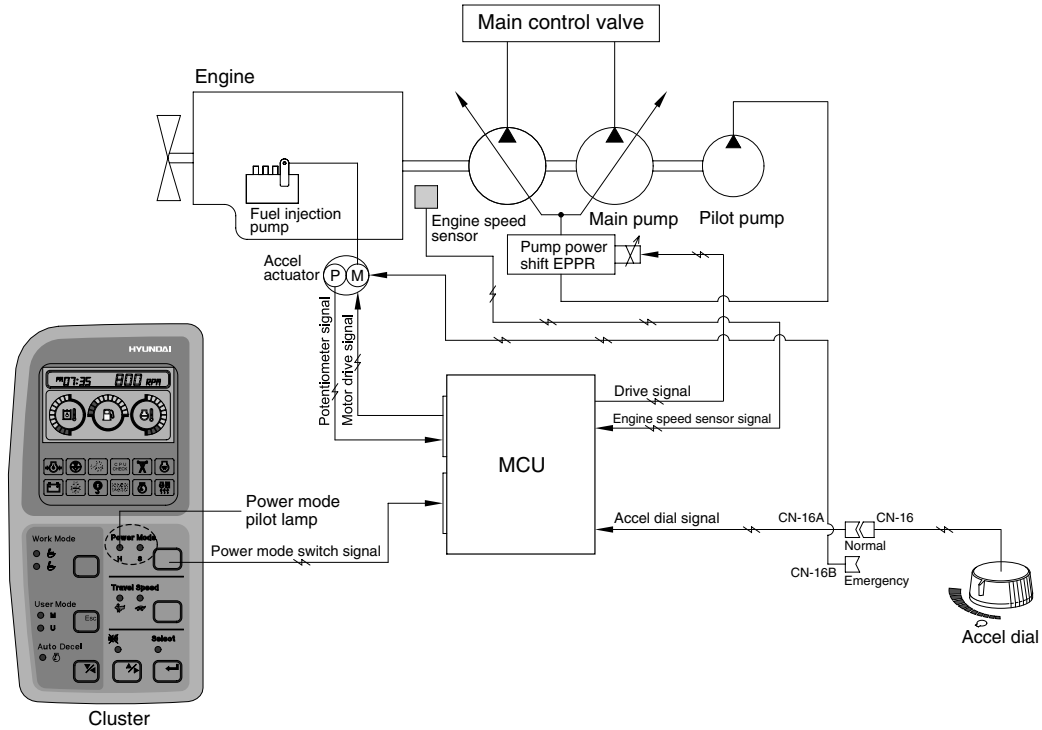

1409S5MS52

Mode selection system (micro computer based electro-hydraulic pump and engine mutual control system) optimizes the engine and pump performance.

The combination of 3 power modes (M, H, S) and accel dial position (10 set) makes it possible to use the engine and pump power more effectively corresponding to the work conditions from a heavy and great power requesting work to a light and precise work.

Power mode	Application	Engine rpm				Power shift by EPPR valve			
		Standard		Option		Standard		Option	
		Unload	Load	Unload	Load	Current (mA)	Pressure (kgf/cm ²)	Current (mA)	Pressure (kgf/cm ²)
M	Maximum power	2100 ± 50	1900 ± 50	2200 ± 50	2000 ± 50	330 ± 30	10	280 ± 30	7
H	High power	2000 ± 50	1800 ± 50	2050 ± 50	1850 ± 50	360 ± 30	12 ± 3	290 ± 30	8 ± 3
S	Standard power	1900 ± 50	1700 ± 50	1950 ± 50	1750 ± 50	360 ± 30	12 ± 3	290 ± 30	8 ± 3
AUTO DECEL	Engine deceleration	1150 ± 100	-	1150 ± 100	-	700 ± 30	38 ± 3	700 ± 30	38 ± 3
One touch decel	Engine quick deceleration	1000 ± 100	-	1000 ± 100	-	700 ± 30	38 ± 3	700 ± 30	38 ± 3
KEY START	Key switch start position	1000 ± 100	-	1000 ± 100	-	700 ± 30	38 ± 3	700 ± 30	38 ± 3

※ Power shift (Standard/Option) can be changed by "Service menu" in "Management" on the cluster.

2. WORK MODE SELECTION SYSTEM

2 Work mode can be selected for the optional work speed of the machine operation.

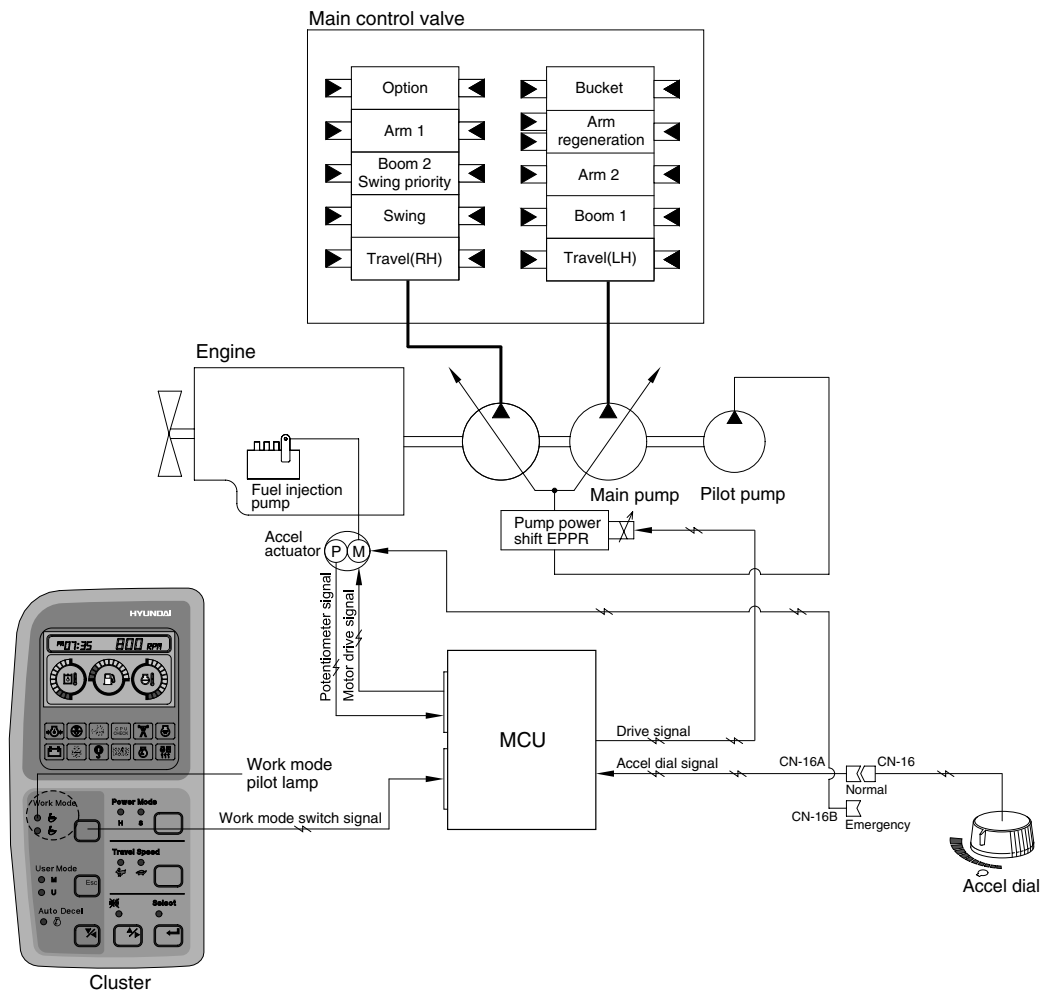

2209S5MS53

1) HEAVY DUTY WORK MODE

Boom and arm operation speed faster than general work mode.

2) GENERAL WORK MODE

When key switch is turned ON, this mode is selected and swing operation speed is faster than heavy duty work mode.

Work mode	Swing priority solenoid	Max flow cut-off solenoid
Heavy duty	OFF	OFF
General	ON	OFF

3. USER MODE SELECTION SYSTEM

An operator can change the engine and pump and memorize it for his preference.

Mode	Operation
U	High idle rpm, auto decel rpm EPPR pressure can be modulated and memorized separately

HOW TO MODULATE THE MEMORY SET

- 1) Each memory mode has a initial set which are mid-range of max engine speed, auto decel rpm, and EPPR valve input current.
- 2) High idle rpm, auto decel rpm, EPPR pressure can be modulated and memorized separately in the U-mode.

※ Refer to the page 5-72 for set of user mode.

· LCD segment vs parameter setting

Segment (■)	ACCEL (rpm)	DECEL (rpm)	EPPR (mA)
1	1500	1000 (low idle)	150
2	1600	1050	200
3	1700	1100	250
4	1800	1150 (decel rpm)	300
5	1900	1200	350
6	2000	1250	400
7	2050	1300	450
8	2100	1350	500
9	2150	1400	550
10	2200	1450	600

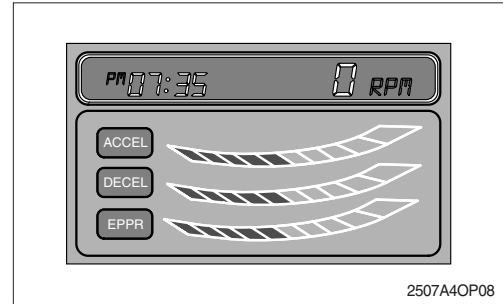

2507A4OP08

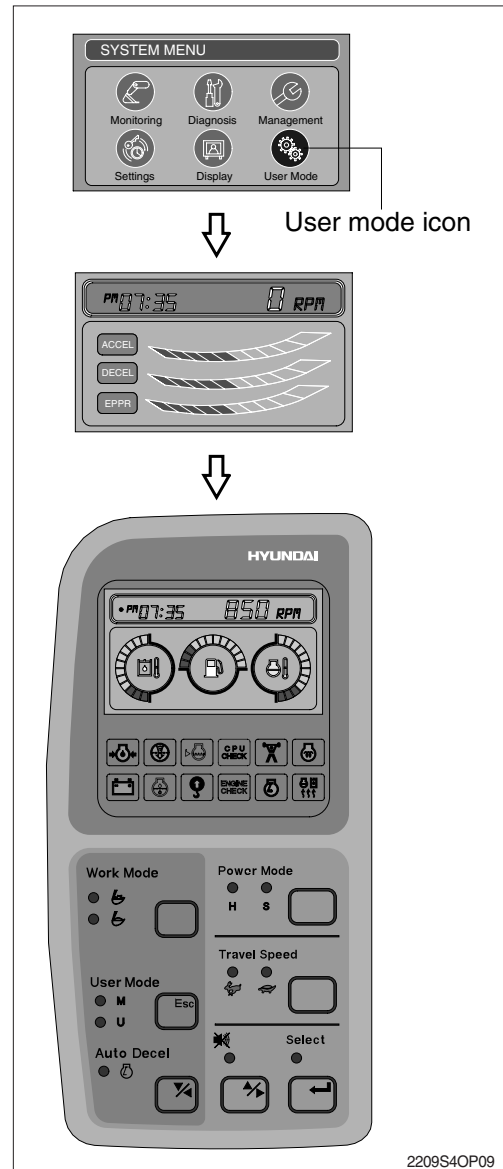

2209S4OP09