

# GROUP 2 ENGINE SYSTEM

## 1. ENGINE AND ACCESSORIES MOUNTING

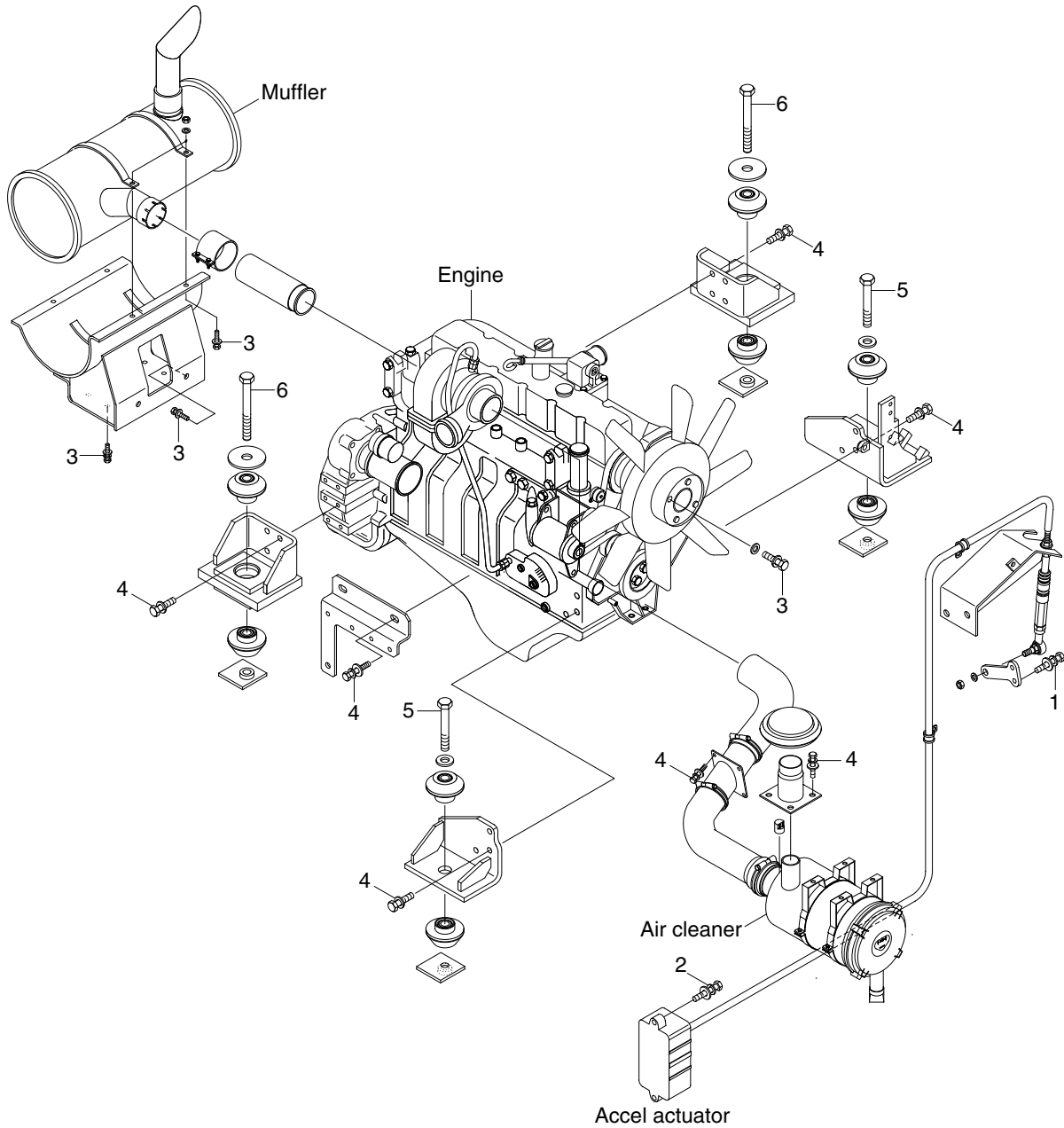

2209S9CM01

· Tightening torque

Item	Size	kgf · m	lbf · ft
1	M6×1.0	1.05±0.2	7.6±1.4
2	M8×1.25	2.5±0.5	18.1±3.6
3	M10×1.5	6.9±1.4	49.9±10.1

Item	Size	kgf · m	lbf · ft
4	M12×1.75	12.8±3.0	92.6±21.7
5	M20×2.5	55±3.5	398±25.3
6	M24×3.0	97±7.0	701±51

## 2. COOLING SYSTEM AND FUEL TANK MOUNTING

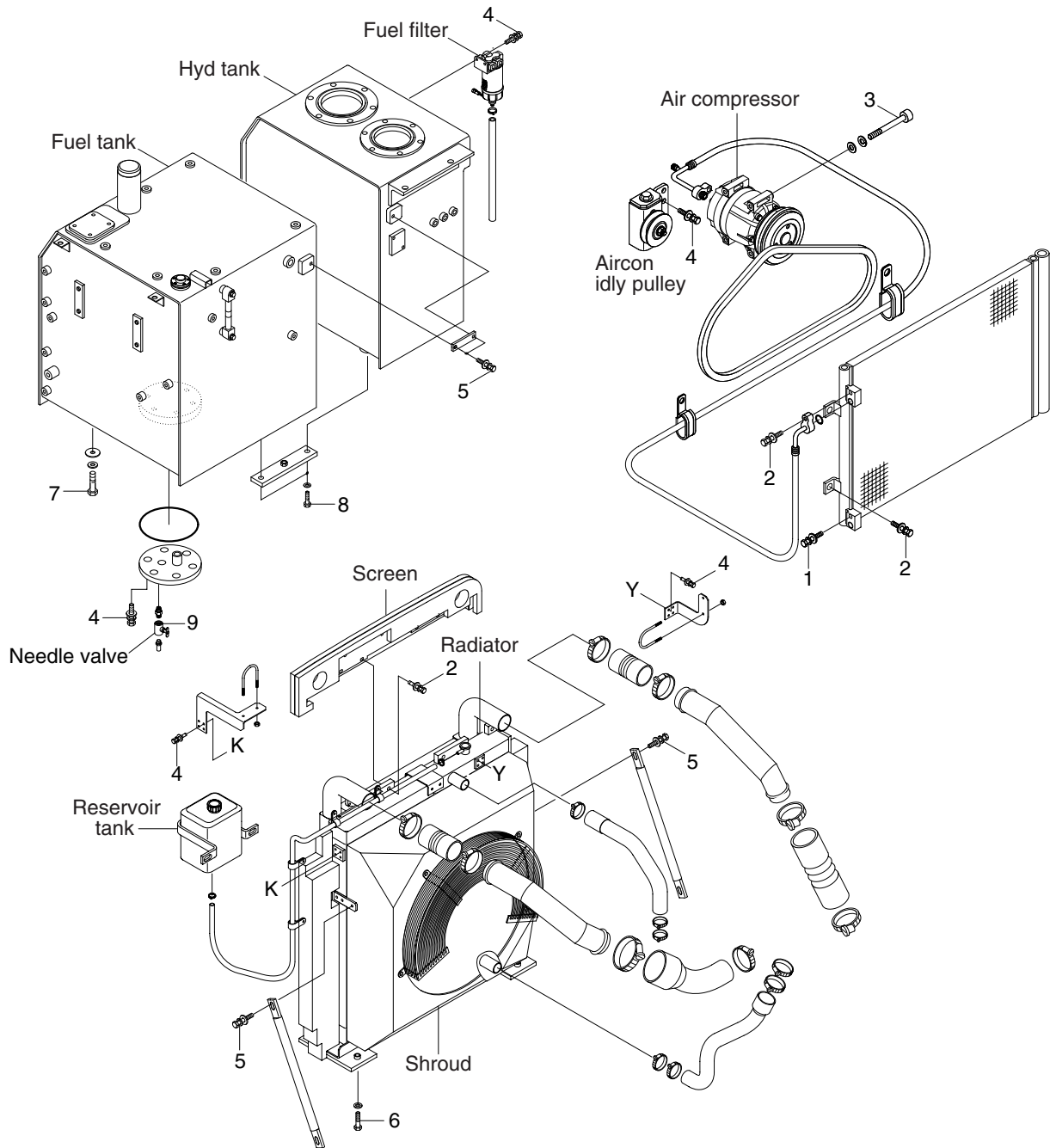

2209S9CM02

### · Tightening torque

Item	Size	kgf · m	lbf · ft
1	M 6×1.0	1.05±0.2	7.6±1.45
2	M 8×1.25	2.5±0.5	18.1±3.6
3	M 8×1.0	4.5±0.9	32.5±6.5
4	M10×1.5	6.9±1.4	49.9±10.1
5	M12×1.75	12.8±3.0	92.6±21.7

Item	Size	kgf · m	lbf · ft
6	M16×2.0	29.7±4.5	215±32.5
7	M20×2.5	46±5.1	333±36.9
8	M20×2.5	57.9±8.7	419±62.9
9	-	2.3±0.6	16.6±4.3