

## SECTION 4 ELECTRICAL SYSTEM

Group 1 Component Location .....	4-1
Group 2 Electrical Circuit .....	4-3
Group 3 Electrical Component Specification .....	4-23
Group 4 Connectors .....	4-31

# SECTION 4 ELECTRICAL SYSTEM

## GROUP 1 COMPONENT LOCATION

### 1. LOCATION 1

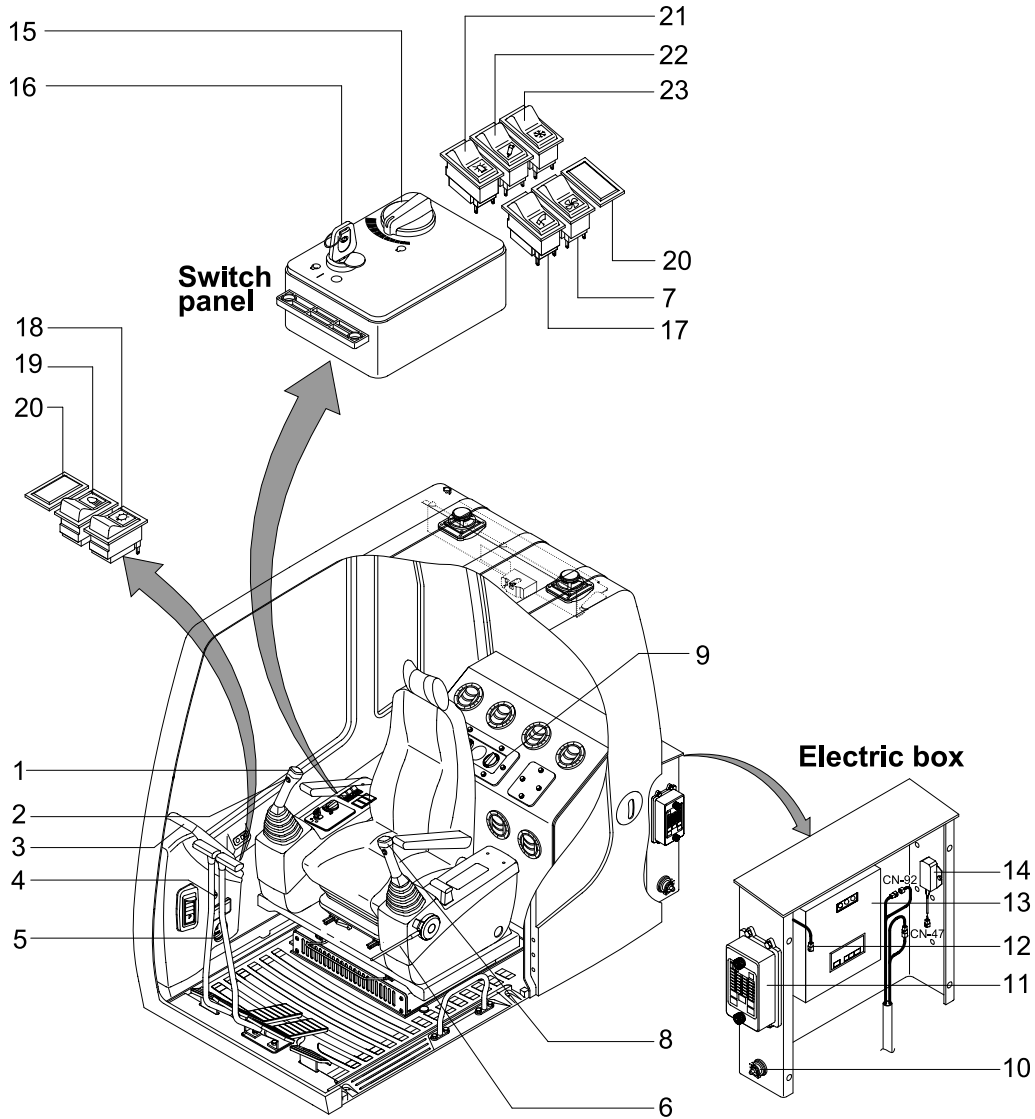

RD21074EL01

- |   |                          |    |                            |    |                          |
|---|--------------------------|----|----------------------------|----|--------------------------|
| 1 | Horn switch              | 9  | Air conditioner controller | 17 | Wiper and washer switch  |
| 2 | Breaker operation switch | 10 | Master switch              | 18 | Main light switch        |
| 3 | Cluster                  | 11 | Fuse box                   | 19 | Cab light switch         |
| 4 | Cigar lighter            | 12 | RS232 serial connector     | 20 | Spare cover              |
| 5 | Hour meter               | 13 | CPU controller             | 21 | Beacon switch            |
| 6 | Safety lever             | 14 | Prolix resistor            | 22 | Breaker selection switch |
| 7 | Fan switch               | 15 | Accel dial switch          | 23 | Air conditioner switch   |
| 8 | One touch decel switch   | 16 | Start switch               |    |                          |

## 2. LOCATION 2

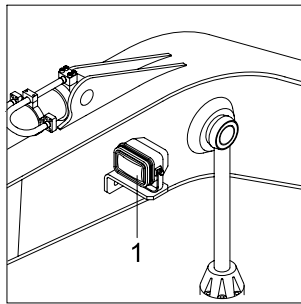

BOOM

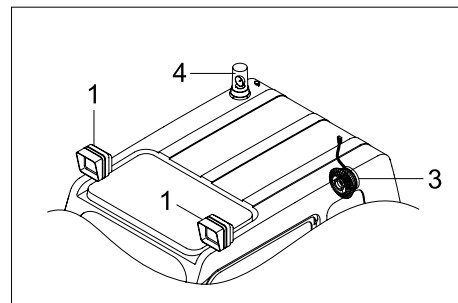

CAB

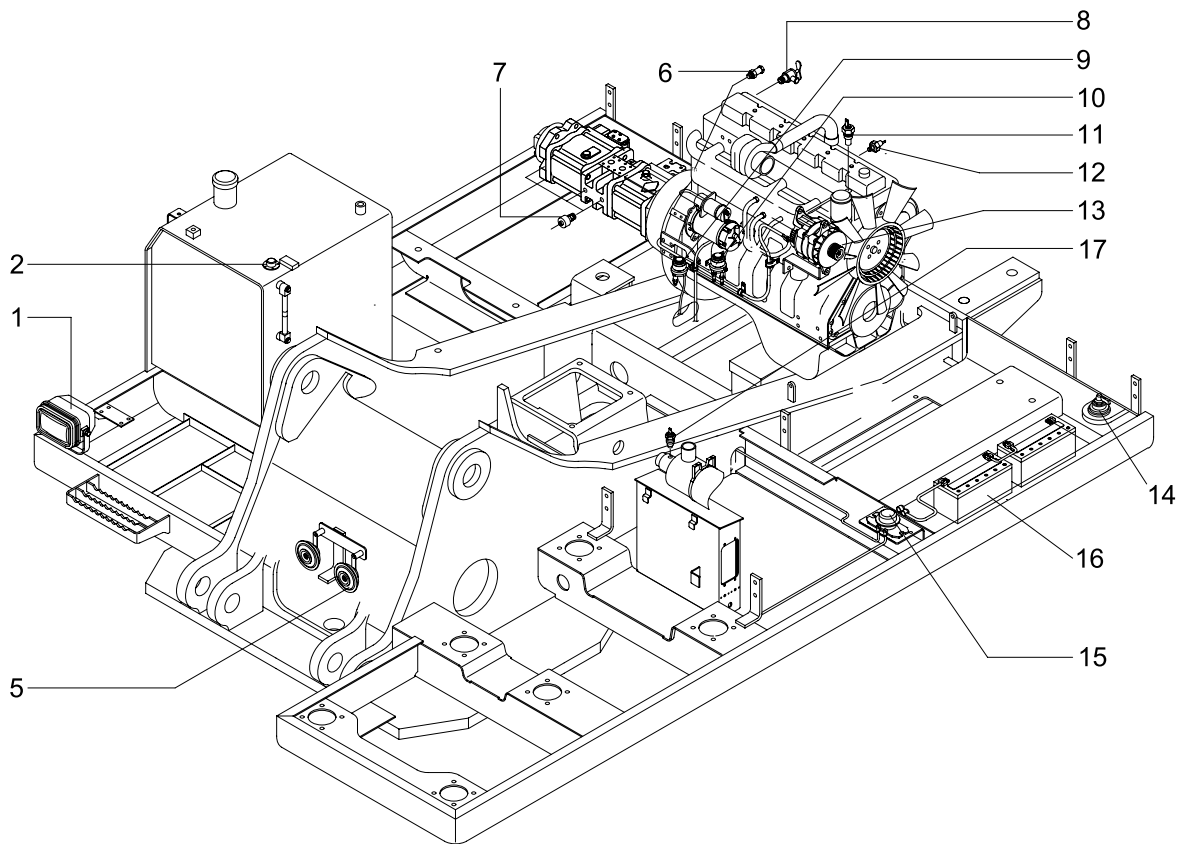

- |   |              |    |                            |    |                    |
|---|--------------|----|----------------------------|----|--------------------|
| 1 | Lamp         | 7  | Pressure sender            | 13 | Alternator         |
| 2 | Fuel sender  | 8  | Heater valve               | 14 | Master switch      |
| 3 | Fan          | 9  | Start relay                | 15 | Battery relay      |
| 4 | Beacon lamp  | 10 | Heater relay               | 16 | Battery            |
| 5 | Horn         | 11 | Temp sender                | 17 | Air cleaner switch |
| 6 | Speed sensor | 12 | Engine oil pressure switch |    |                    |

RD21074EL02

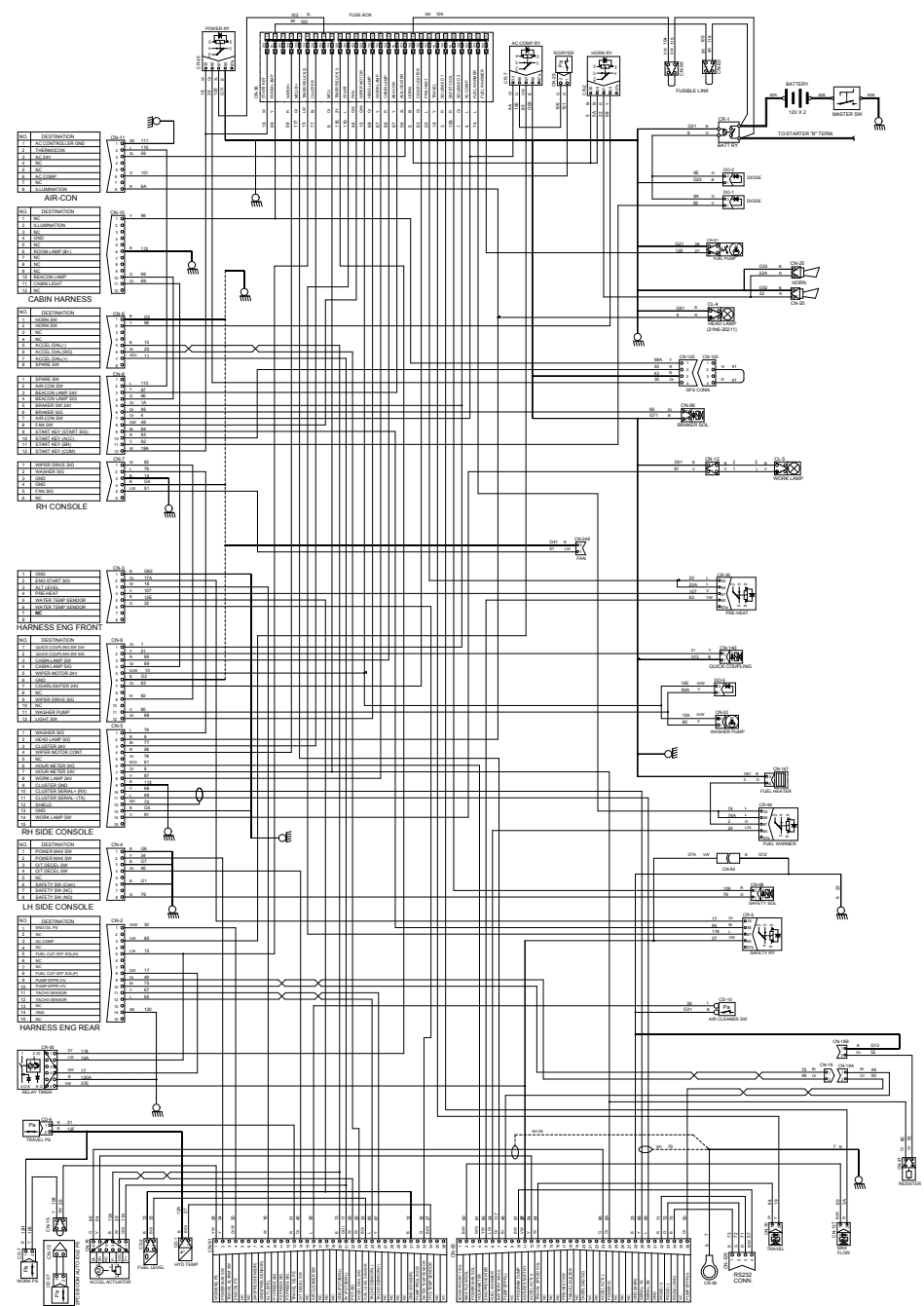
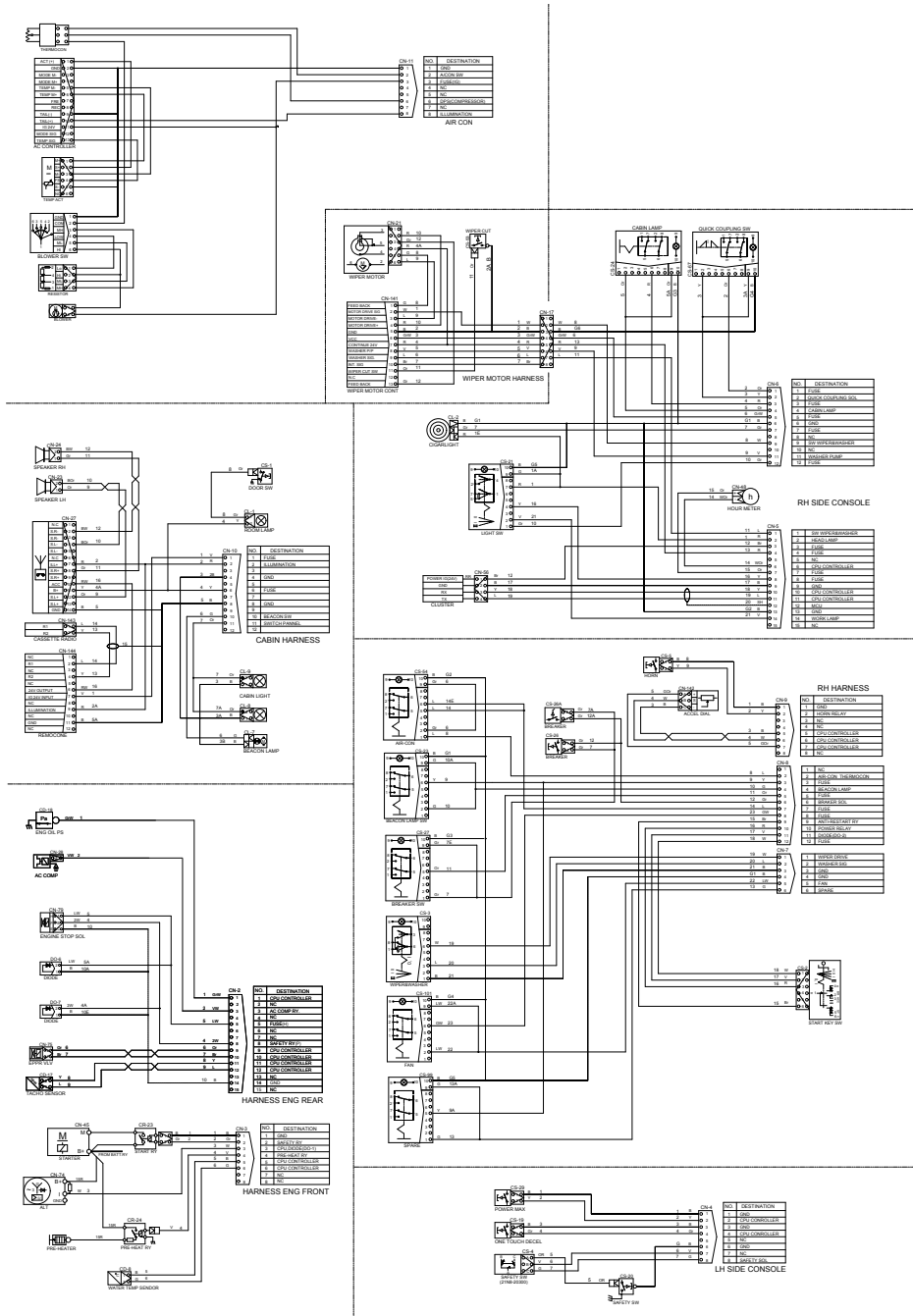

## 1. POWER CIRCUIT

The negative terminal of battery is grounded to the machine chassis through master switch.  
When the start switch is in the OFF position, the current flows from the positive battery terminal as shown below.

### 1) OPERATING FLOW

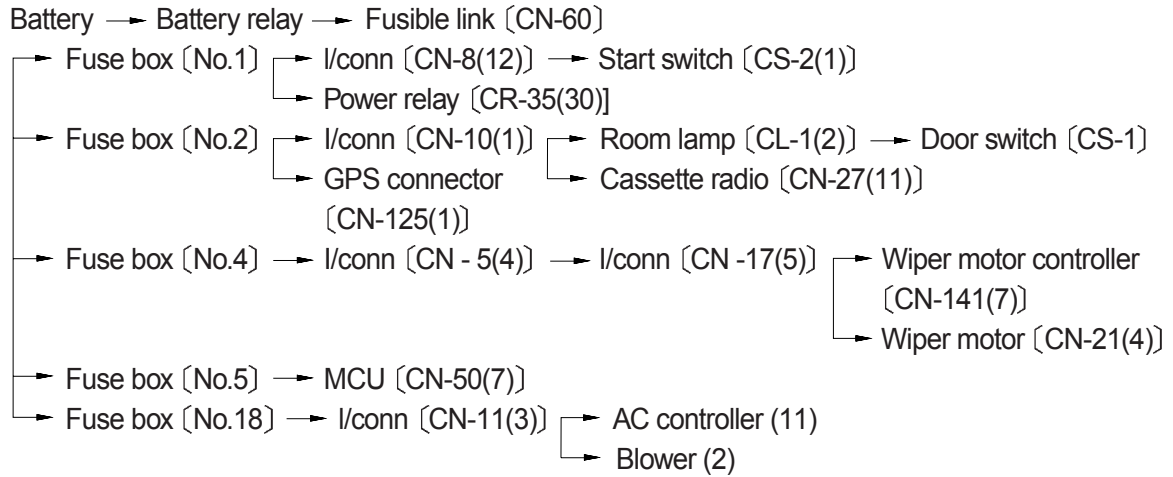

※ I/conn : Intermediate connector

### 2) CHECK POINT

Engine	Start switch	Check point	Voltage
OFF	OFF	① - GND (Battery 1EA) ② - GND (Battery 2EA) ③ - GND (Battery 2EA) ④ - GND (Fusible link)	10~12.5V 20~25V 20~25V 20~25V

※ GND : Ground

# POWER CIRCUIT

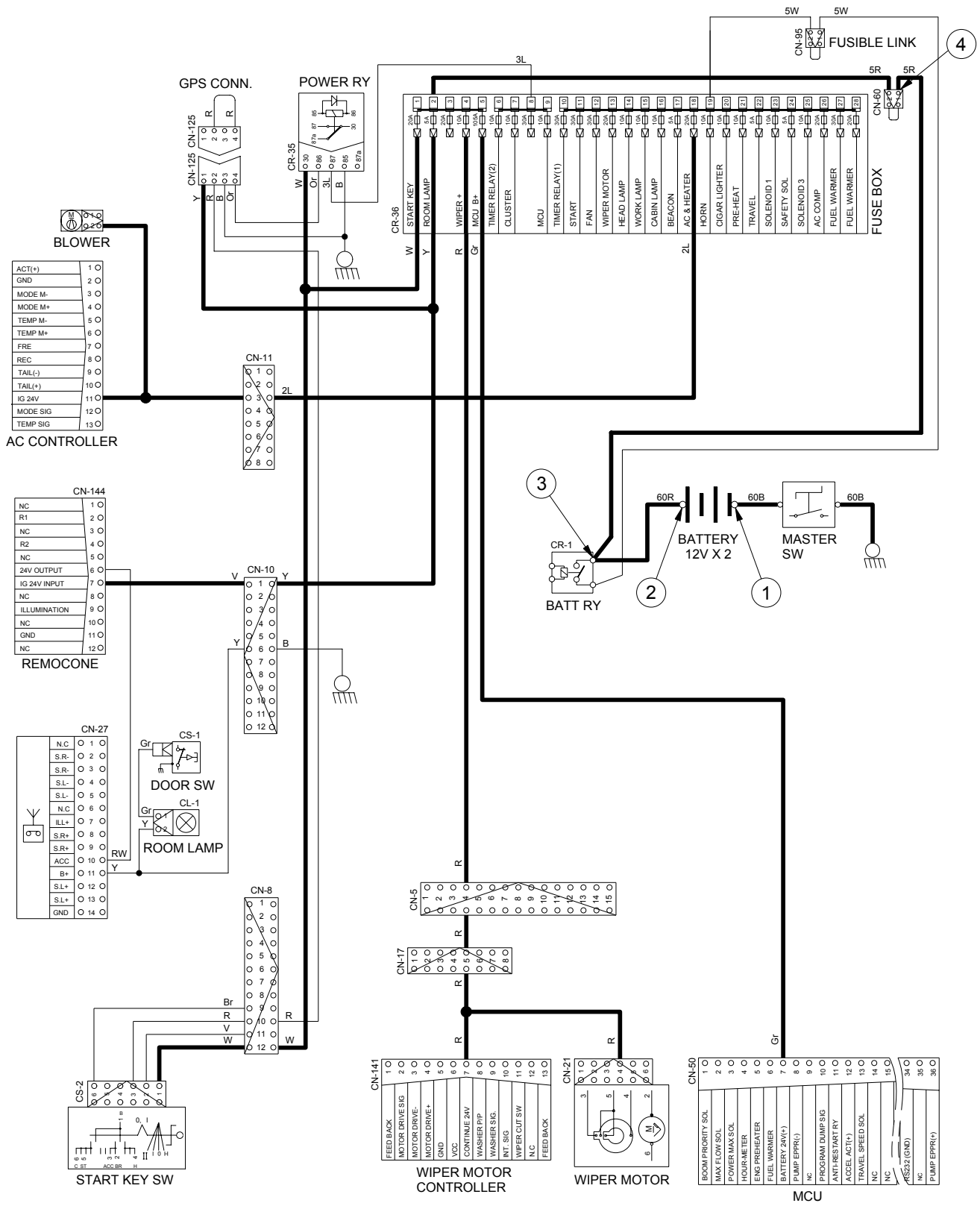

## 2. STARTING CIRCUIT

### 1) OPERATING FLOW

Battery(+) terminal → Battery relay[CR-1] → Fusible link[CN-60] → Fuse box [No.1]  
 → I/conn [CN-8(12)] → Start key [CS-2(1)]

※ Start switch : ON

→ Start switch ON [CS-2(2)] → I/conn [CN-8(11)] → Diode[DO-2] →  
 Battery relay [CR-1]; Battery relay operating (All power is supplied with the electric component)  
 → Start switch ON [CS-2(3)] → I/conn [CN-8(10)] → GPS connector [CN-125(2)→(4)]  
 → Power relay [CR-35(86)→(87)] → Fuse box [No.6] → Relay timer [CR-50(2)→(4)]  
 → I/conn [CN-2(8)] → Fuel cut-off [CN-79(B)]

※ Start switch : START

Start switch START [CS-2(6)] → I/conn [CN-8(9)] → Safety relay [CR-5(86) → (30)]  
 → I/conn [CN-3(2)] → Start relay [CR-23]

### 2) CHECK POINT

Engine	Start switch	Check point	Voltage
Operating	Start	① - GND (Battery) ② - GND (Start key) ③ - GND (Battery relay M4) ④ - GND (Starter B) ⑤ - GND (Starter M) ⑥ - GND (Start relay) ⑦ - GND (Battery relay M8)	20 ~ 25V

※ GND : Ground

# STARTING CIRCUIT

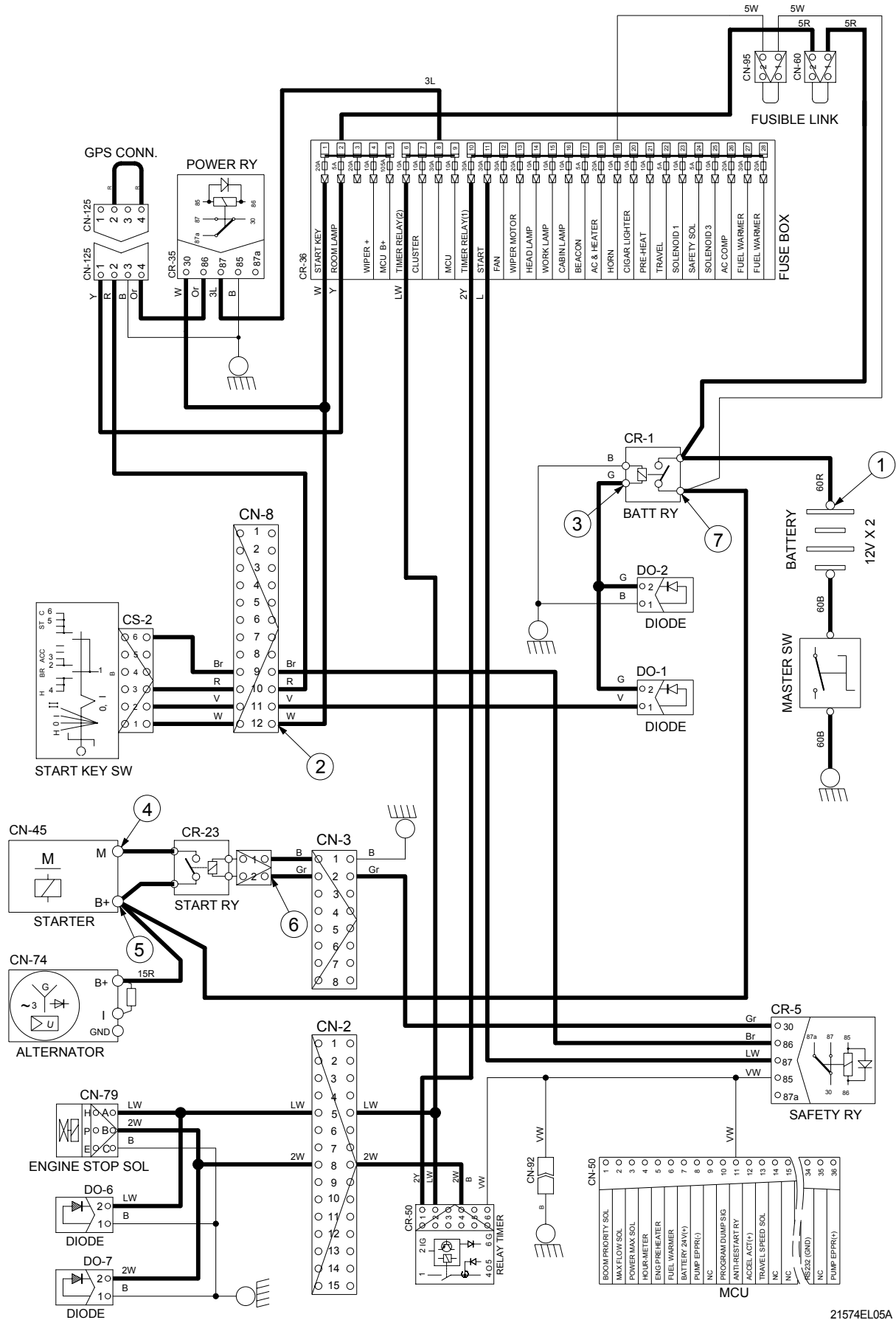

21574EL05A



### 3. CHARGING CIRCUIT

When the starter is activated and the engine is started, the operator releases the key switch to the ON position.

Charging current generated by operating alternator flows into the battery through the Battery relay(CR-1).

The current also flows from alternator to each electrical component and controller through the fuse box.

#### 1) OPERATING FLOW

##### (1) Warning flow

Alternator "I" terminal → I/conn [CN-3(3)] → MCU [CN-51(9)] →  
Cluster warning lamp(Via serial interface)

##### (2) Charging flow

Alternator "B+" terminal → Battery relay(M8) → Battery(+) terminal  
Fusible link[CN-60] → Fuse box

#### 2) CHECK POINT

Engine	Start switch	Check point	Voltage
ON	ON	① - GND (Battery voltage) ② - GND (Battery relay) ③ - GND (Alternator B terminal) ④ - GND (Alternator I terminal) ⑤ - GND (CPU)	20 ~ 275V

※ GND : Ground

# CHARGING CIRCUIT

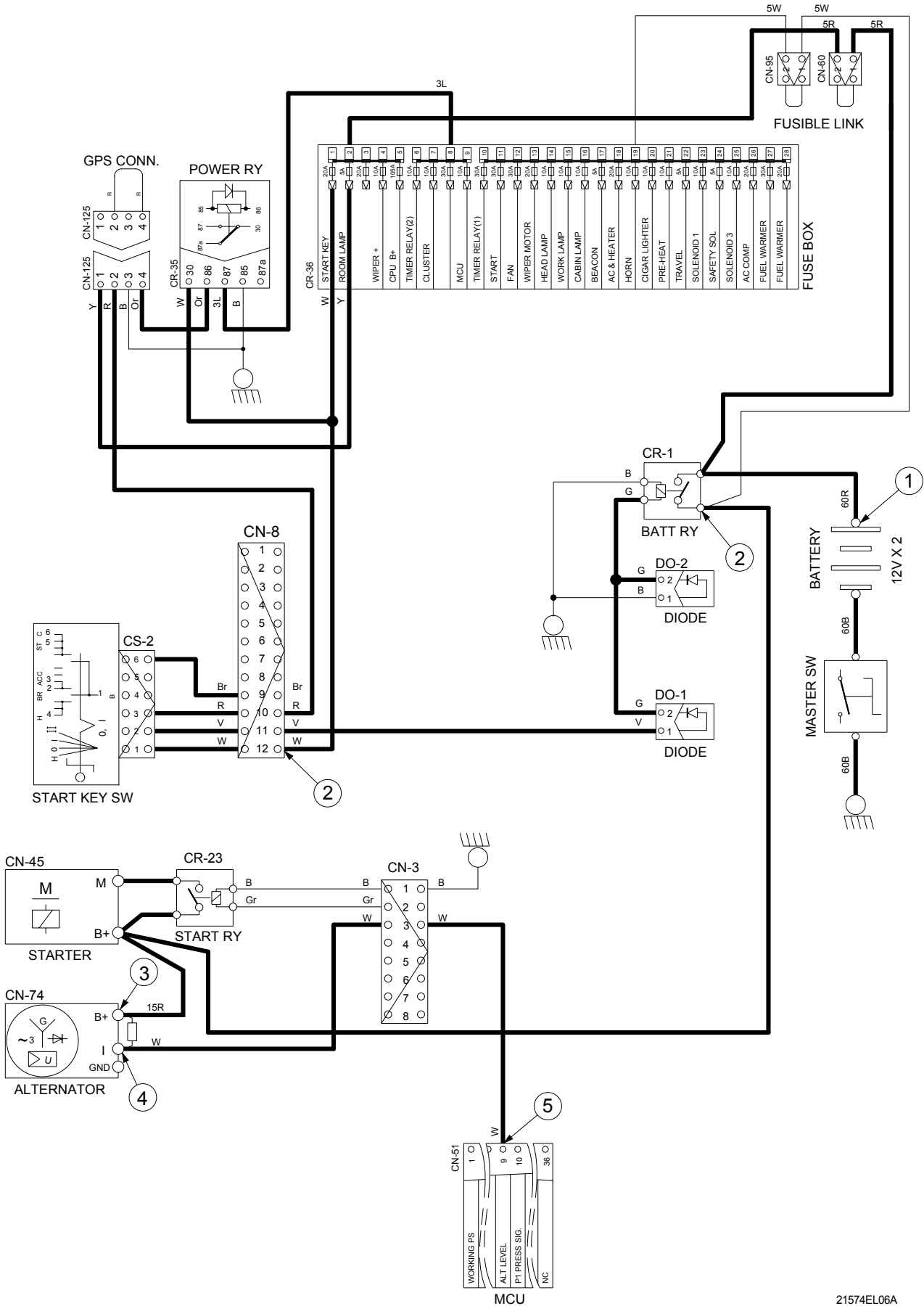

21574EL06A

## 4. HEAD LAMP CIRCUIT

### 1) OPERATING FLOW

Fuse box (No.14) → I/conn [CN-6(12)] → CS-21(1)

※ When lamp switch ON

Light switch [CS-21(7)]

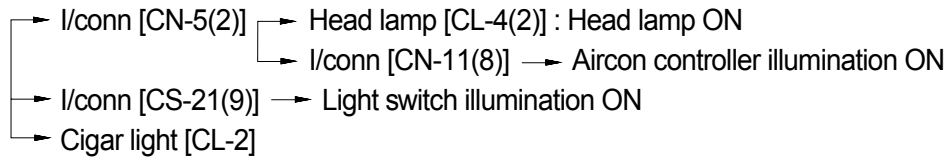

### 2) CHECK POINT

Engine	Key switch	Check point	Voltage
STOP	ON	① - GND (Fuse box) ② - GND (Switch power input) ③ - GND (Switch power output)	20~25V

※ GND : Ground

# HEAD LAMP CIRCUIT

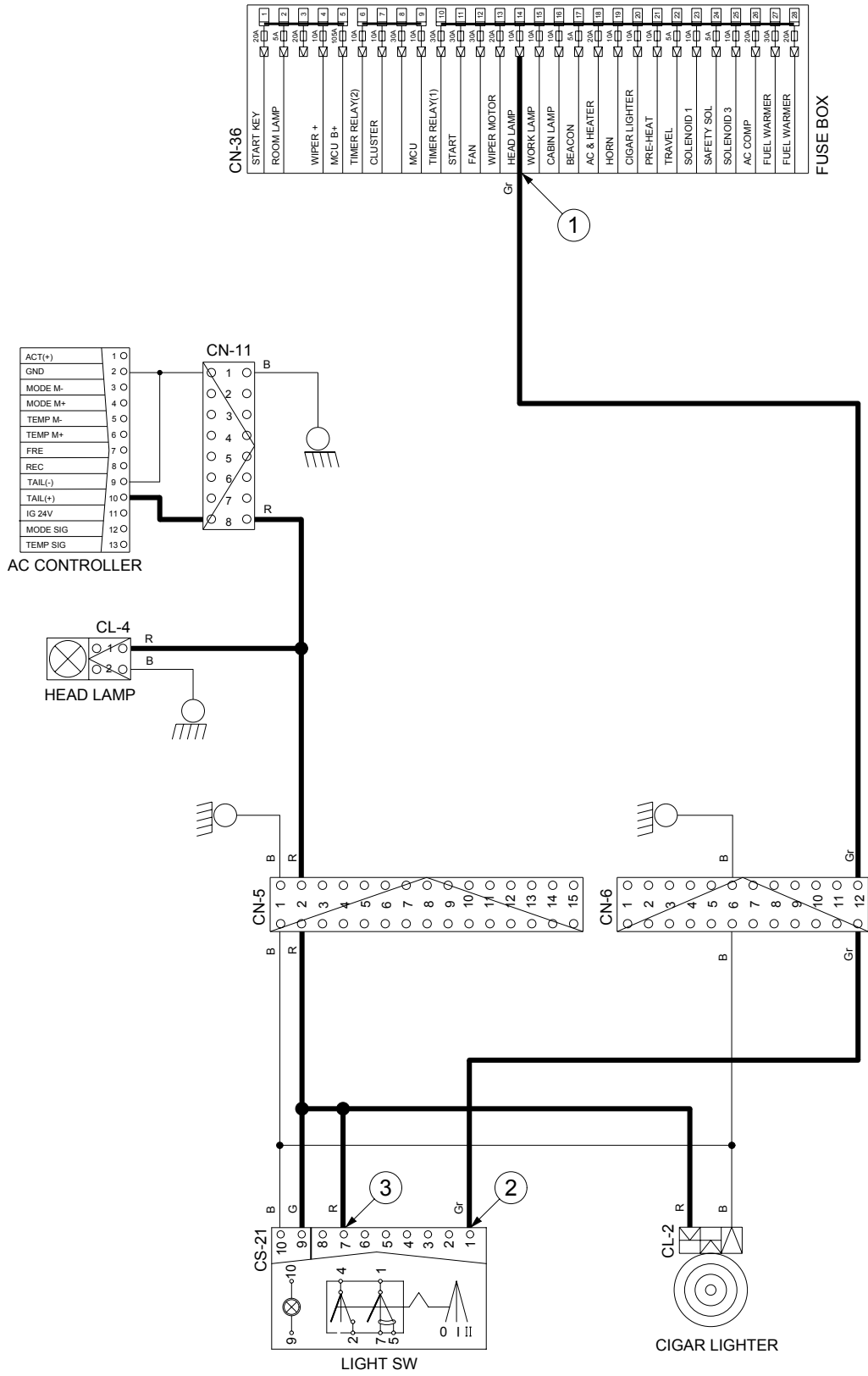

21574EL07A

## 5. WORK LAMP CIRCUIT

### 1) OPERATING FLOW

Fuse box (No.15) → I/conn [CN-5(8)] → Light switch [CS-21(4)]

※ When work lamp switch ON

Work lamp switch ON [CS-21(2)] → I/conn [CN-5(14)] → I/conn [CN-12(1)]

→ Work lamp ON [CL-5(2)]

### 2) CHECK POINT

Engine	Start switch	Check point	Voltage
STOP	ON	① - GND (Fuse box) ② - GND (Switch power input) ③ - GND (Switch power output) ④ - GND (Work lamp)	20~25V

※ GND : Ground

# WORK LAMP CIRCUIT

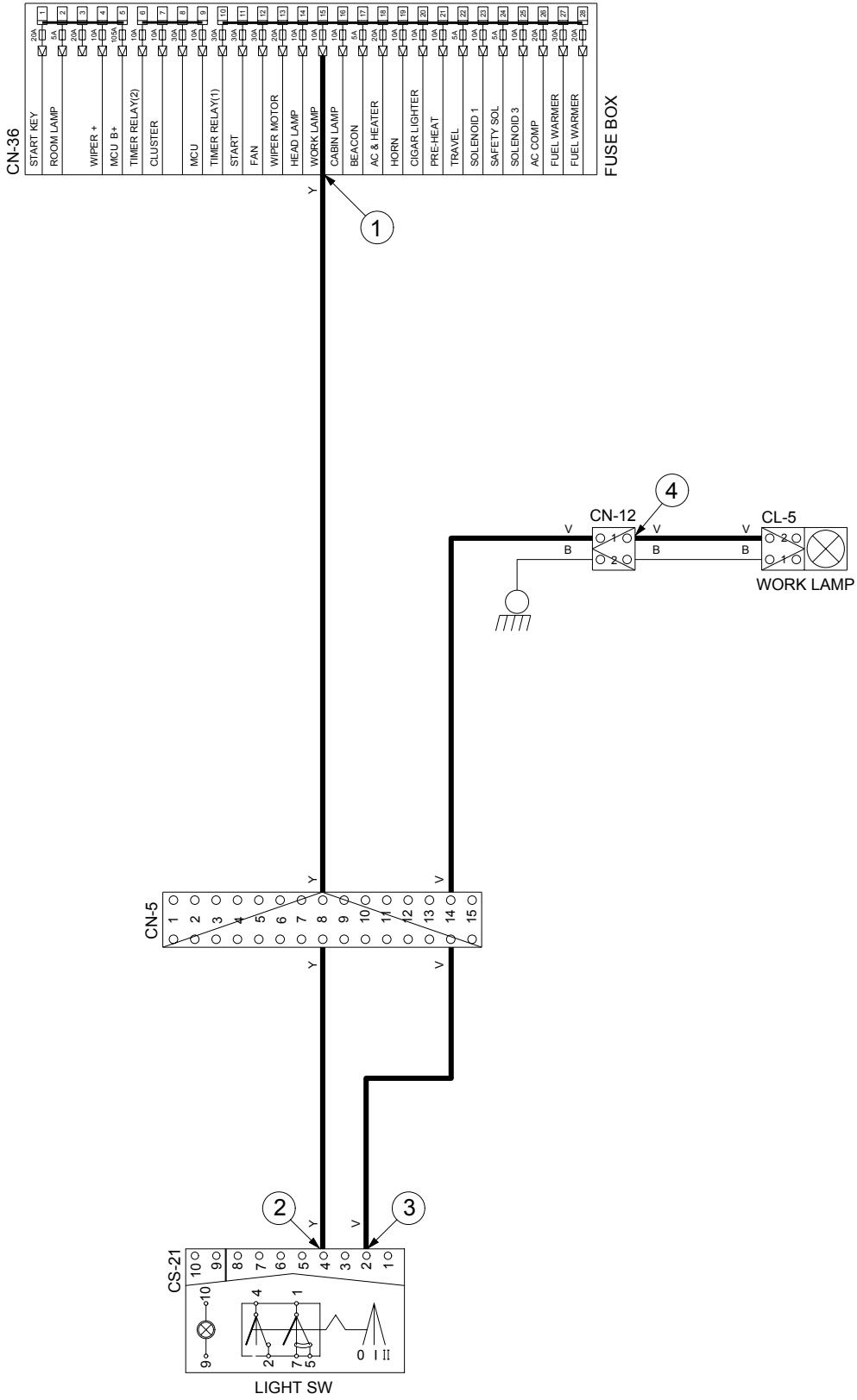

## 6. CAB LAMP CIRCUIT

### 1) OPERATING FLOW

Fuse box (No.16) → I/conn [CN-6(3)] → Cabin lamp switch[CS-24(6)]

※ When Lamp switch ON

Lamp switch ON [CS-24(2)] → I/conn [CN-6(4)] → I/conn [CN-10(11)] →  
Cab light ON [CL-8(2), CL-9(2)]

### 2) CHECK POINT

Engine	Start switch	Check point	Voltage
STOP	ON	① - GND (Fuse box) ② - GND (Switch power input) ③ - GND (Switch power output) ④ - GND (Cab lamp)	20 ~ 25V

※ GND : Ground

# CAB LAMP CIRCUIT

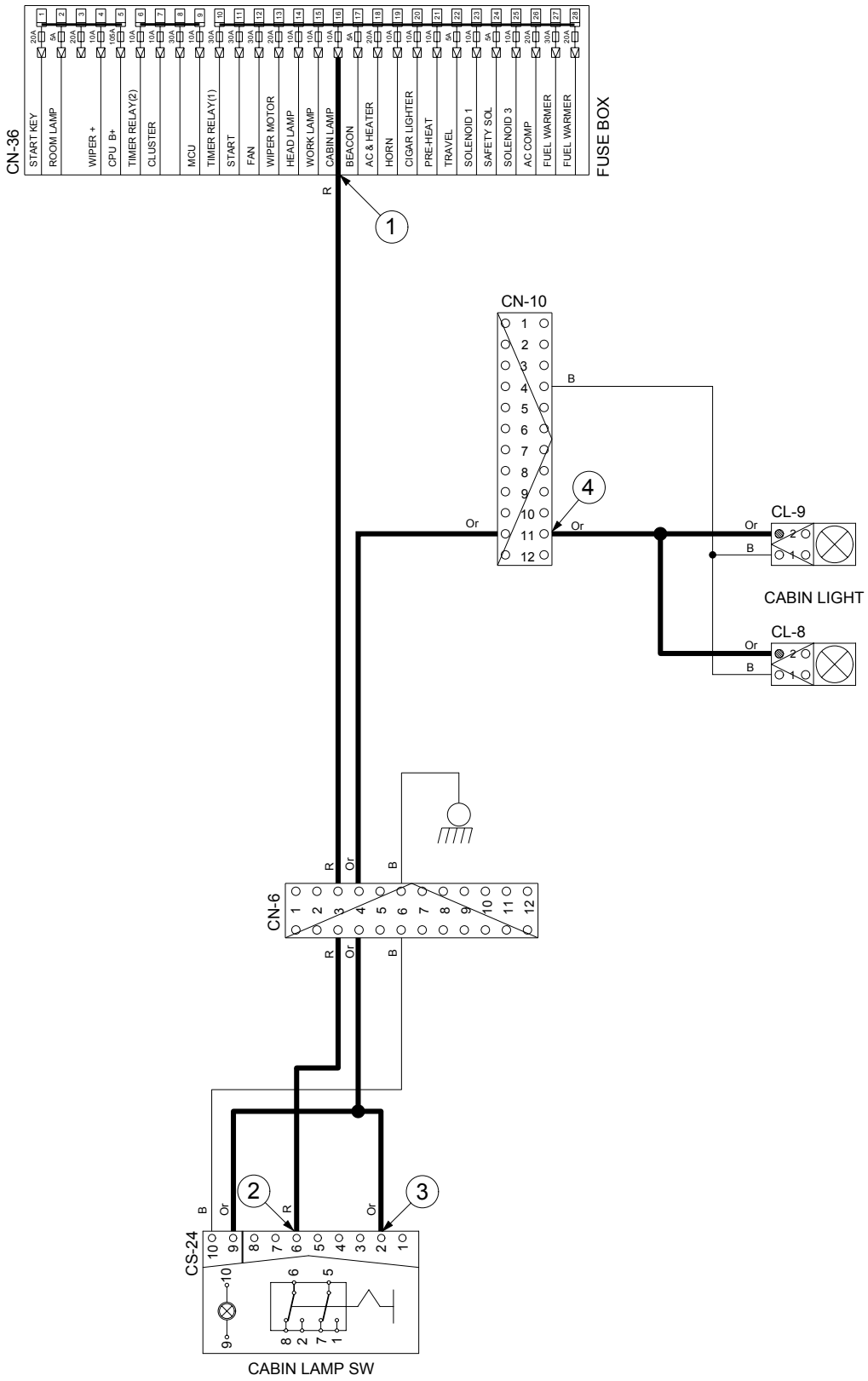



## 7. BEACON LAMP CIRCUIT

### 1) OPERATING FLOW

Fuse box (No.17) → I/conn [CN-8(3)] → Beacon lamp switch [CS-23(6)]

※ When lamp switch ON

Beacon lamp switch ON [CS-23(2)] → Switch Indicator lamp ON [CS-23(9)]  
→ I/conn [CN-8(4)] → I/conn [CN-10(10)]  
→ Beacon lamp ON [CL-7]

### 2) CHECK POINT

Engine	Start switch	Check point	Voltage
STOP	ON	① - GND(Fuse box) ② - GND(Switch power input) ③ - GND(Switch power output) ④ - GND(Beacon lamp)	20~25V

※ GND : Ground

# BEACON LAMP CIRCUIT

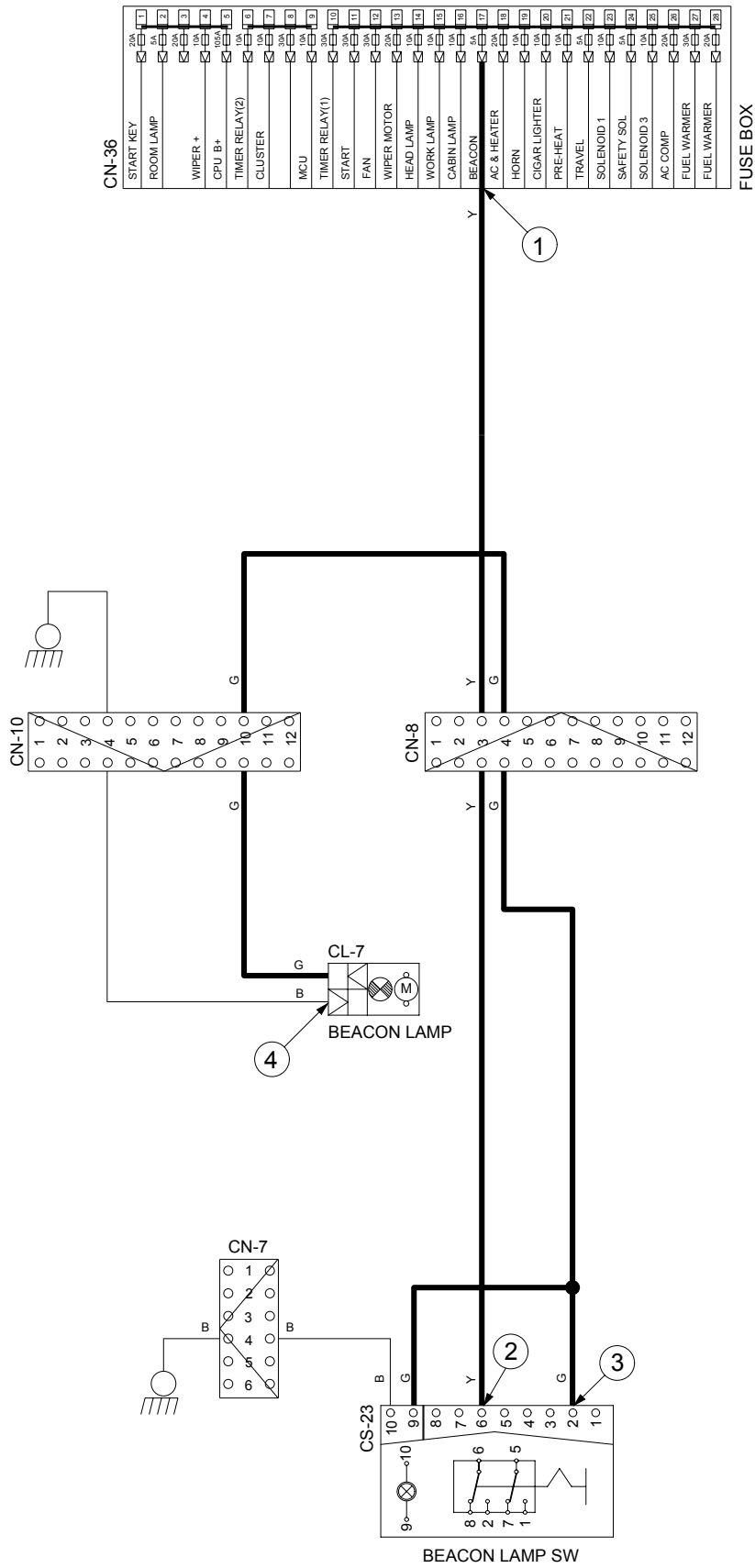

## 8. WIPER AND WASHER CIRCUIT

### 1) OPERATING FLOW

#### (1) Key switch ON

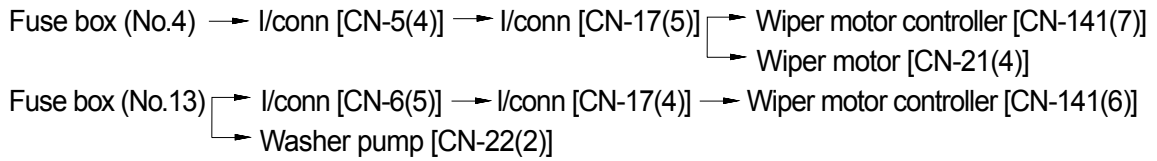

#### (2) Wiper switch ON : 1st step

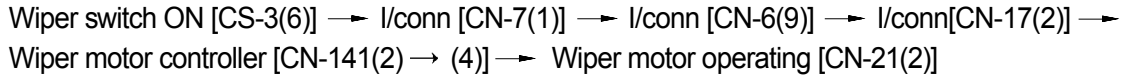

#### (3) Washer switch ON : 2nd step(washer)

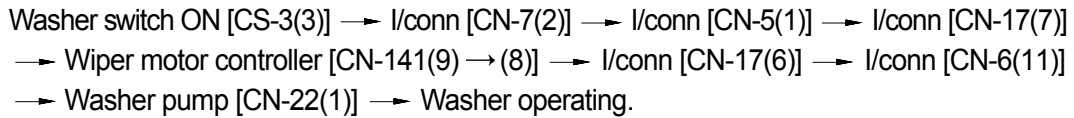

#### (4) Auto parking(When switch OFF)

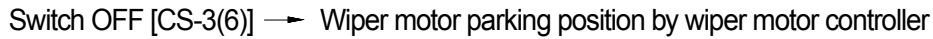

### 2) CHECK POINT

Engine	Start switch	Check point	Voltage
STOP	ON	① - GND(Fuse box) ② - GND(Switch power output) ③ - GND(Wiper Power input) ④ - GND(Wiper power output) ⑤ - GND(Wiper motor)	20~25V

※ GND : Ground

# WIPER AND WASHER CIRCUIT

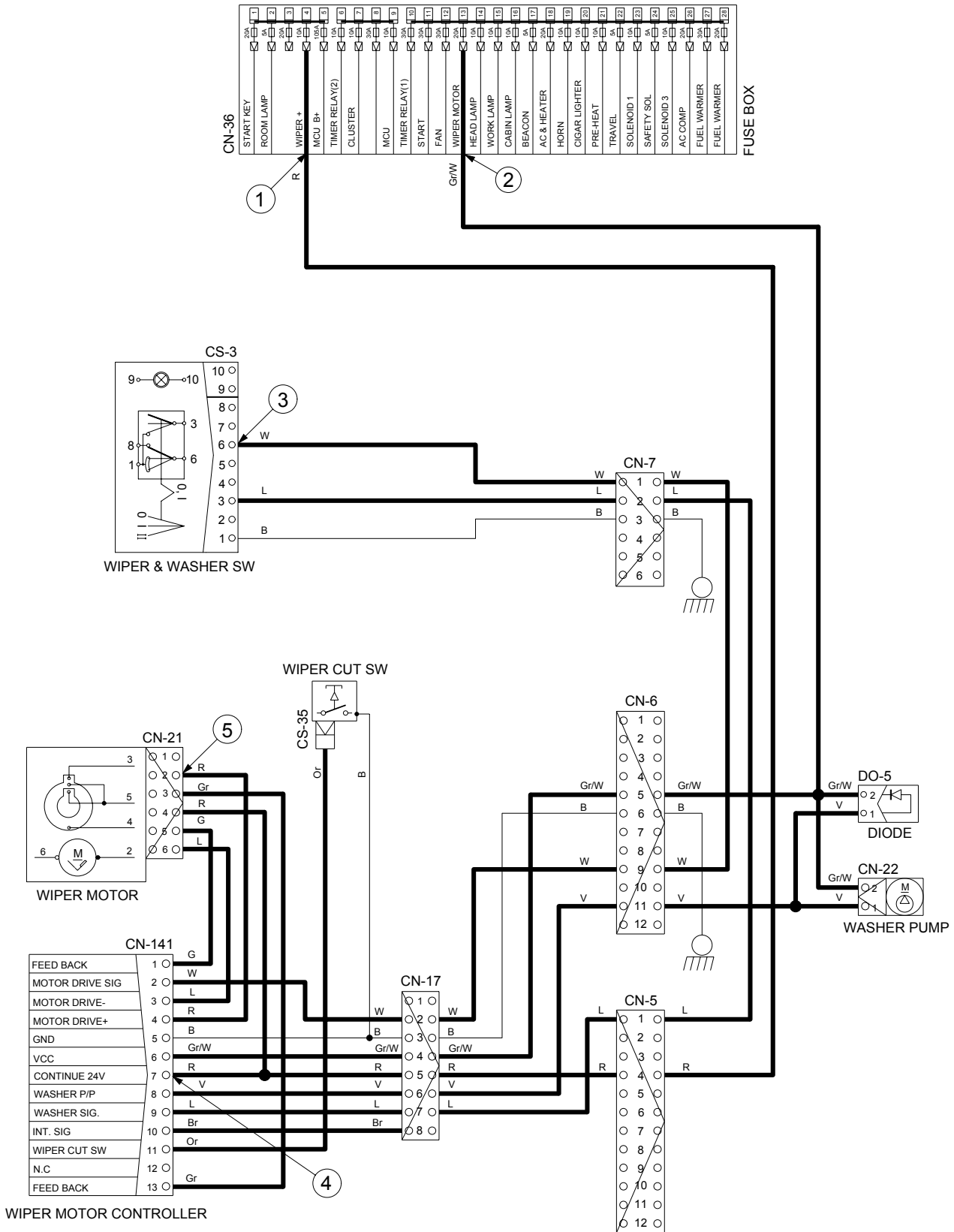

# CONTROLLER CIRCUIT

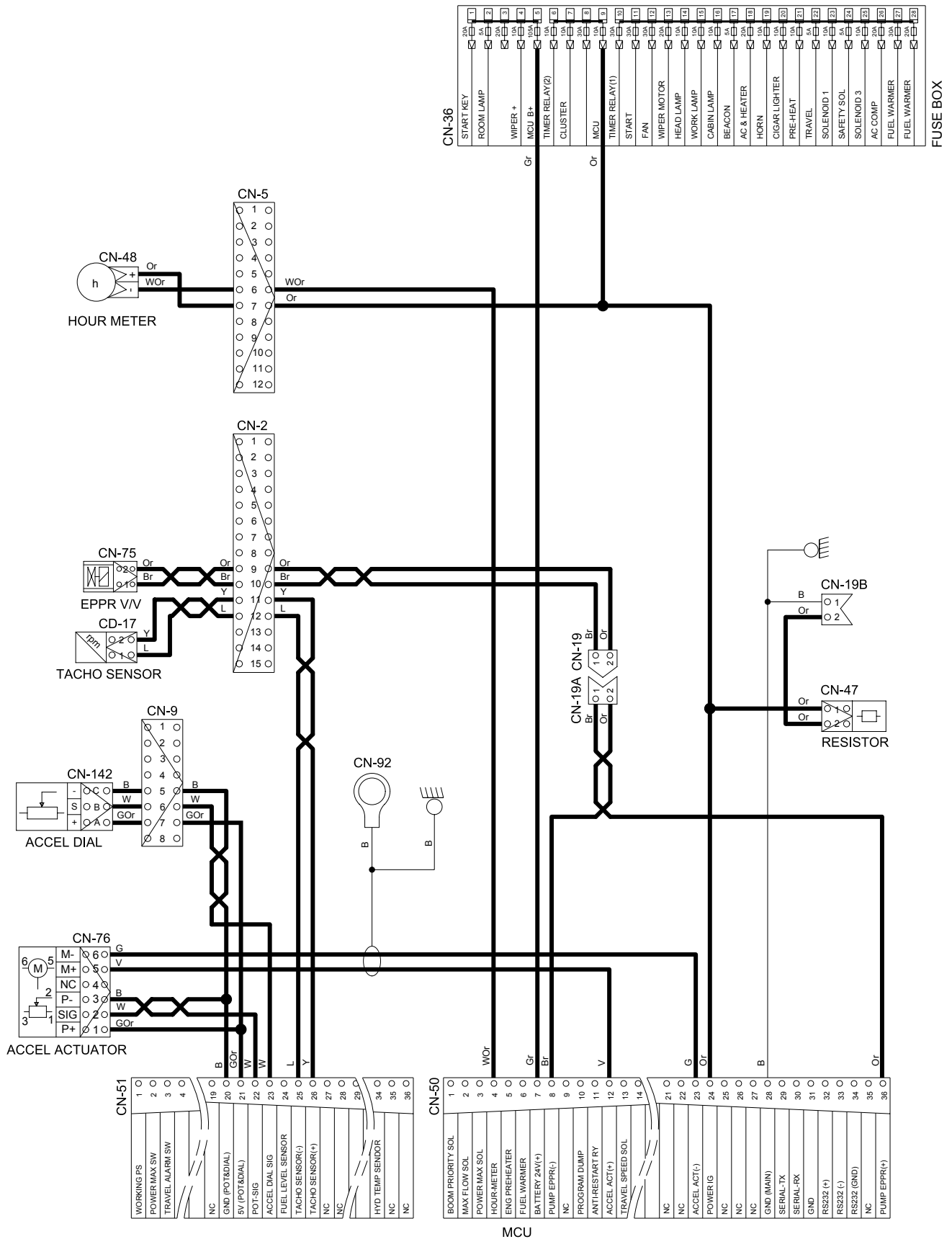

# MONITORING CIRCUIT

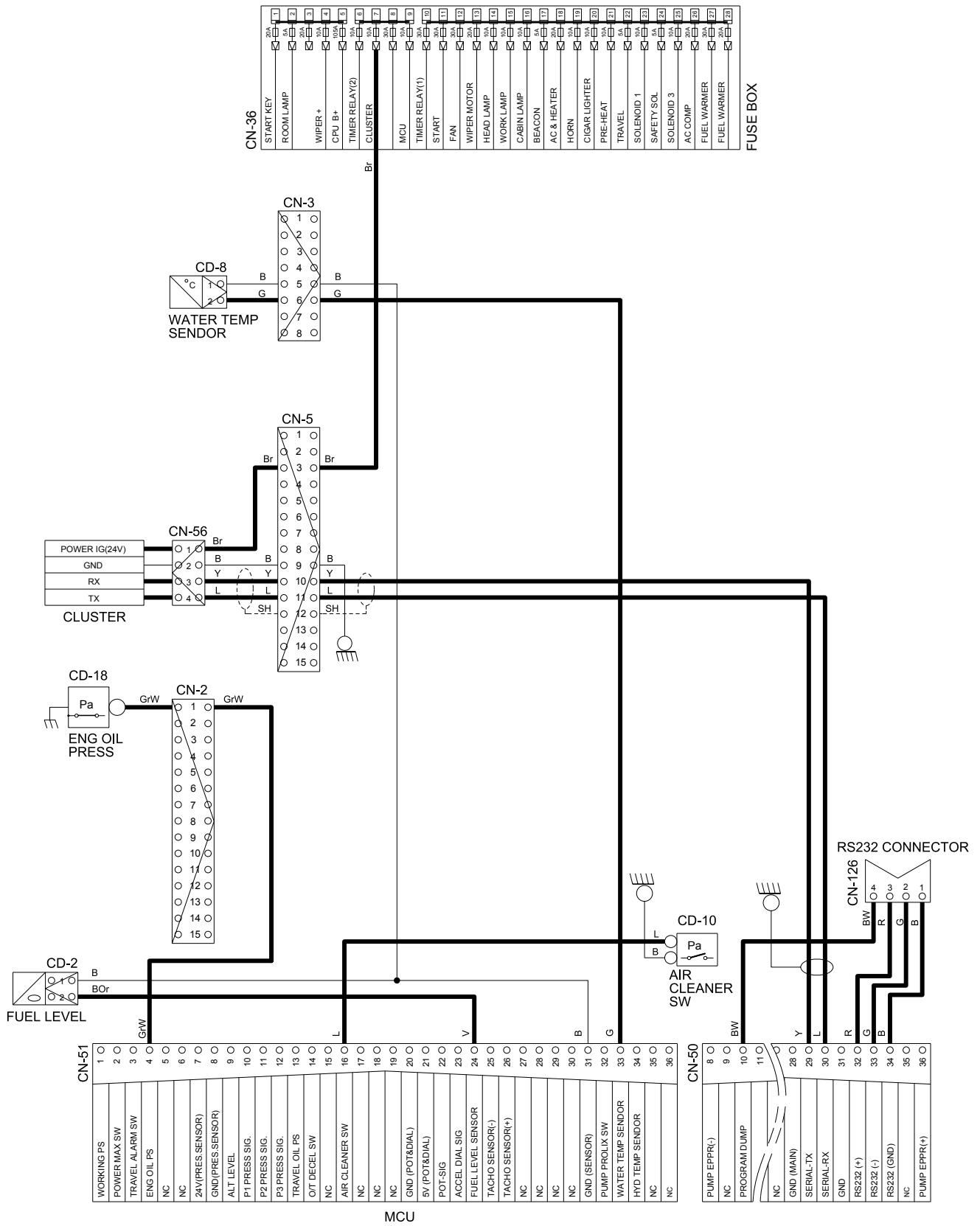

# ELECTRIC CIRCUIT FOR HYDRAULIC

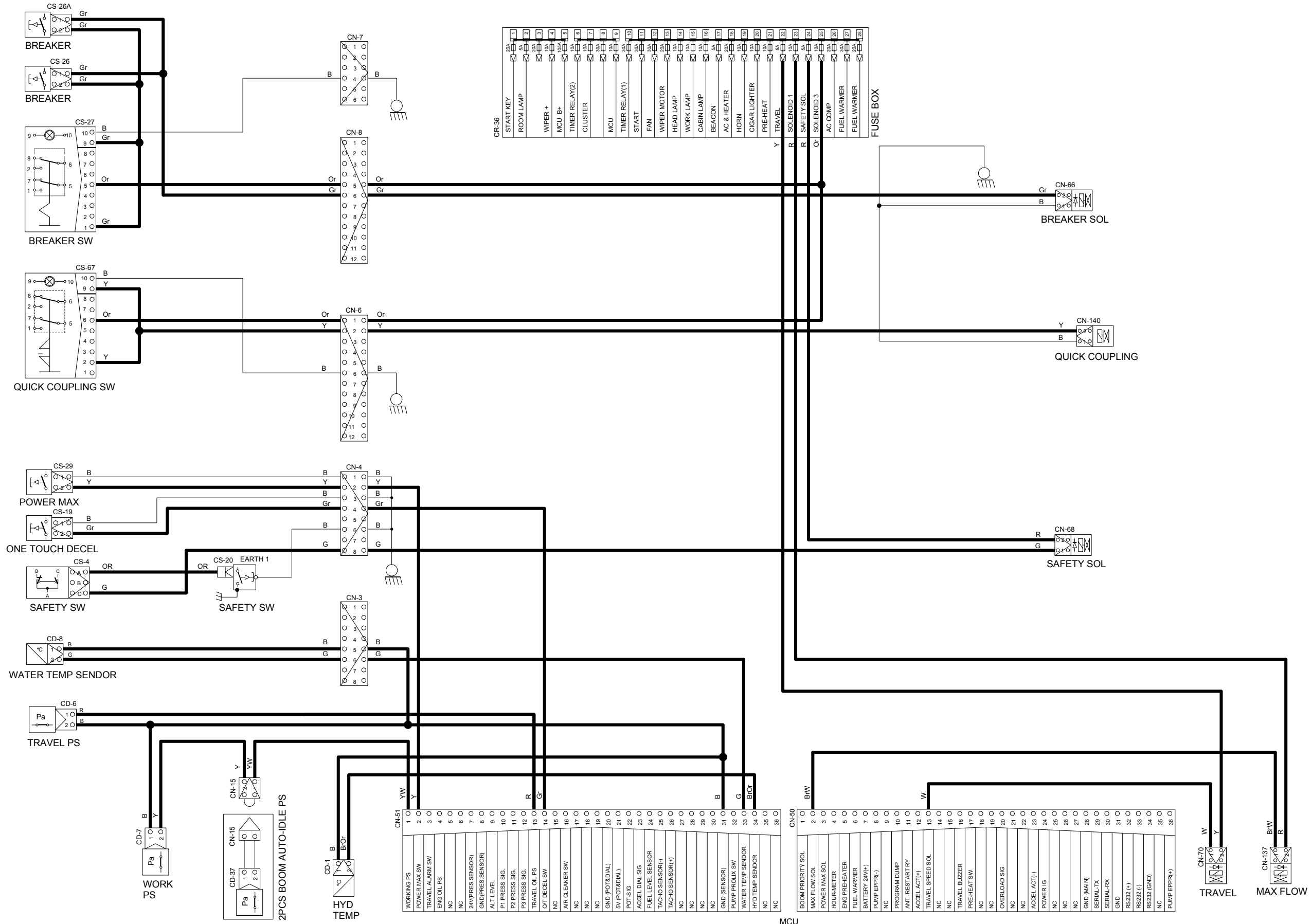

## GROUP 3 ELECTRICAL COMPONENT SPECIFICATION

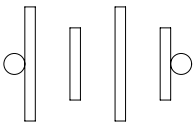
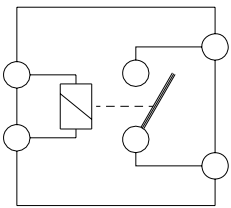
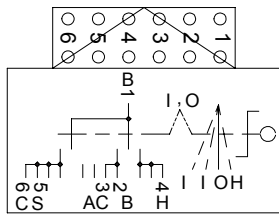
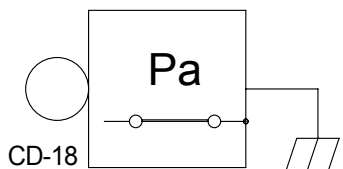
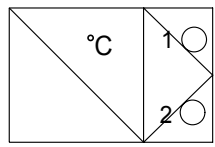
Part name	Symbol	Specification	Check
Battery		12V × 100Ah (2EA)	※ Check specific gravity 1.280 over : Over charged 1.280 ~ 1.250 : Normal 1.250 below : Recharging
Battery relay	 <p style="text-align: center;">CR-1</p>	Rated load : 24V 100A(continuity) 1000A(30seconds)	※ Check coil resistance (M4 to M4) Normal : About 50 Ω ※ Check contact Normal : ∞ Ω
Start key		B-BR : 24V 1A B-ACC : 24V 10A B-ST : 24V 40A	※ Check contact OFF : ∞ Ω (For each terminal) ON : 0 Ω (For terminal 1-3 and 1-2) START : 0 Ω (For terminal 1-5)
Pressure switch (For engine oil)	 <p style="text-align: center;">CD-18</p>	0.5 kgf/cm <sup>2</sup> (N.C TYPE)	※ Check resistance Normal : 0 Ω (CLOSE)
Temperature sensor	 <p style="text-align: center;">CD-1 CD-8</p>	-	※ Check resistance 50°C : 804 Ω 80°C : 310 Ω 100°C : 180 Ω

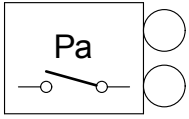
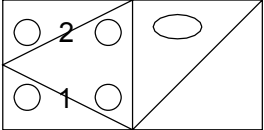
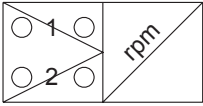
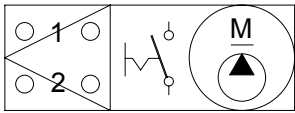
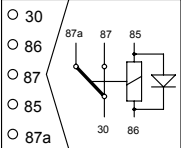
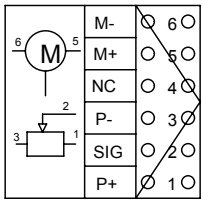

Part name	Symbol	Specification	Check
Air cleaner pressure switch	 CD-10	Pressure: 635mmH <sub>2</sub> O (N.O TYPE)	※ Check contact Normal : ∞ Ω
Fuel sender	 CD-2	-	※ Check resistance Full : 50 Ω      6/12 : 350 Ω 11/12 : 100 Ω    5/12 : 400 Ω 10/12 : 150 Ω    4/12 : 450 Ω 9/12 : 200 Ω     3/12 : 500 Ω 8/12 : 250 Ω     2/12 : 550 Ω 7/12 : 300 Ω     1/12 : 600 Ω Empty warning : 700 Ω
Tacho sensor	 CD-17	-	※ Check resistance Normal : 300 Ω (For terminal 1,2)
Fuel filler pump	 CN-61	24V 10A 35 ℓ /min	※ Check resistance Normal : 1.0 Ω
Relay (Horn, Safety, Ac comp, Power, Preheat, Fuel warmer)	 CR-2 CR-35 CR-5 CR-36 CR-7 CR-46	24V 16A	※ Check resistance Normal : About 160 Ω (For terminal 85-86) : 0 Ω (For terminal 30-87a) : ∞ Ω (For terminal 30-87)
Accel actuator	 CN-76	-	※ Check resistance Normal : 1-2 Ω (For terminal 5-6) 0.8-1.2kΩ (For terminal 1-3)

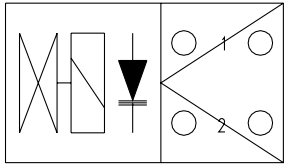
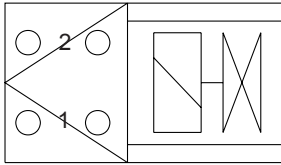
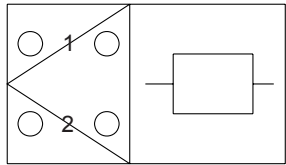
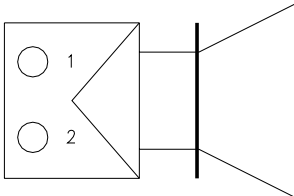
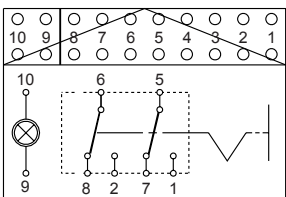
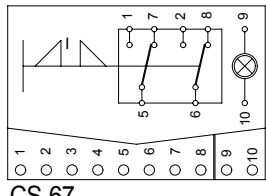
Part name	Symbol	Specification	Check
Solenoid valve	 CN-66 CN-68 CN-70 CN-137	24V 1A	※ Check resistance Normal : 15~25 Ω (For terminal 1-2)
EPPR valve	 CN-75	700mA	※ Check resistance Normal : 18~25 Ω (For terminal 1-2)
Resistor	 CN-47	50 Ω 20W ± 5%	※ Check resistance Normal : 50 Ω
Speaker	 CN-23(LH) CN-24(RH)	4 Ω 20W	※ Check resistance Normal : 4 Ω
Switch (Locking type)	 CS-23 CS-24 CS-27 CS-54 CS-99 CS-101	24V 8A	※ Check contact Normal ON - 0 Ω (For terminal 1-5,2-6) - ∞ Ω (For terminal 5-7,6-8) OFF - ∞ Ω (For terminal 1-5,2-6) - 0 Ω (For terminal 5-7,6-8)
Switch (Quick clamp)	 CS-67	24V 8A	※ Check contact Normal ON - 0 Ω (For terminal 1-5,2-6) - ∞ Ω (For terminal 5-7,6-8) OFF - ∞ Ω (For terminal 1-5,2-6) - 0 Ω (For terminal 5-7,6-8)

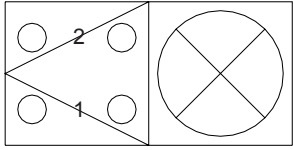
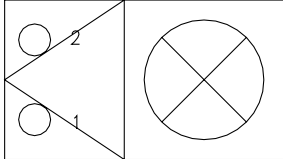
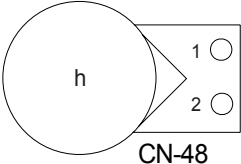
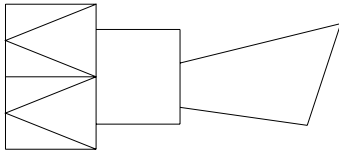
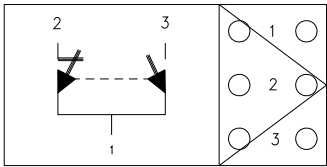
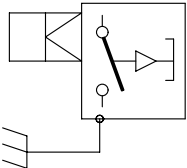
Part name	Symbol	Specification	Check
Head lamp, Work lamp, Cab lamp	 CL-4 CL-5 CL-6 CL-8 CL-9	24V 70W (H3 TYPE)	※ Check disconnection Normal : 1.2 Ω
Room lamp	 CL-1	24V 10W	※ Check disconnection Normal : A few Ω
Hour meter	 CN-48	16V ~ 32V	※ Check operation · Supply power(24V) to terminal No. 2 and connect terminal No. 1 and ground.
Horn	 CN-20 CN-25	DC 22.0 ~ 28.0V 2A	※ Check operation · Supply power(24V) to each terminal and connect ground.
Safety switch 1	 CS-4	24V 15A (N.C TYPE)	※ Check contact Normal : 0 Ω (For terminal 1-2) : ∞ Ω (For terminal 1-3) Operating : ∞ Ω (For terminal 1-2) : 0 Ω (For terminal 1-3)
Safety switch 2 Wiper cut sw	 CS-20 CS-53	24V (N.C TYPE)	※ Check contact Normal : 0 Ω (one pin to ground)

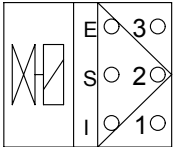
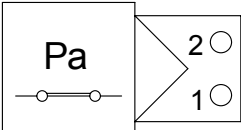
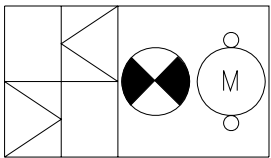
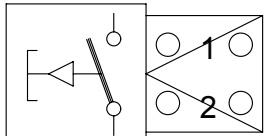
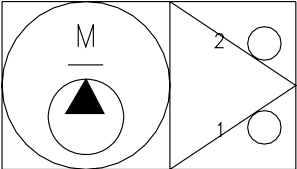
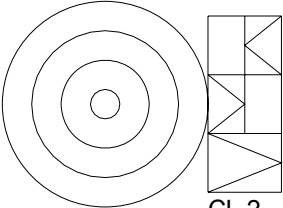
Part name	Symbol	Specification	Check
Fuel cut-off	 <p>CN-79</p>	24V	※ Check resistance Normal : 15~25 Ω
Pressure switch (Travel, Work)	 <p>CD-6 CD-7</p>	10bar (N.C type)	※ Check contact Normal : 0.1 Ω
Beacon lamp	 <p>CL-7</p>	24V 70W	※ Check disconnection Normal : 1.1 Ω
Switch (Power max, One touch decel, Breaker, Horn)	 <p>CS-5 CS-19 CS-26 CS-26A CS-29</p>	24V 6A	※ Check contact Normal : ∞ Ω
Washer tank	 <p>CN-22</p>	24V 3.8A	※ Check contact Normal : 10.7 Ω (For terminal 1-2)
Cigar lighter	 <p>CL-2</p>	24V 5A 1.4W	※ Check coil resistance Normal : About 1MΩ ※ Check contact Normal : ∞ Ω Operating time : 5~15sec

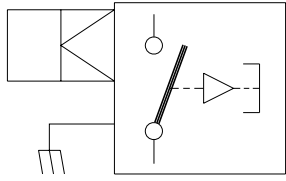
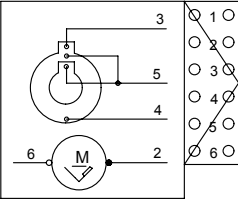
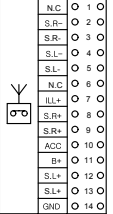
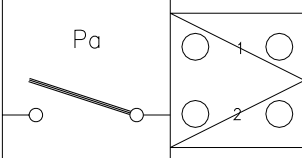
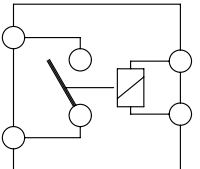
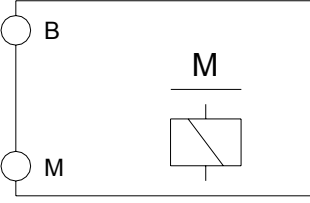
Part name	Symbol	Specification	Check
Door switch	 <p>CS-1</p>	24V 2W	※ Check resistance Normal : About 5MΩ
Wiper motor	 <p>CN-21</p>	24V 2A	※ Check contact Normal : 7 Ω (For terminal 2-6)
Cassette radio	 <p>CN-27</p>	24V 2A	※ Check voltage 20 ~ 25V (For terminal 10-14,11-14)
Receiver dryer	 <p>CN-29</p>	24V 2.5A	※ Check contact Normal : 0 Ω
Start relay	 <p>CR-23</p>	24V 300A	※ Check contact Normal : 0.94 Ω (For terminal 1-2)
Starter	 <p>CN-45</p>	Delco Remy 28MT 24V	※ Check contact Normal : 0.1 Ω

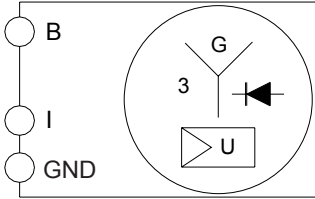
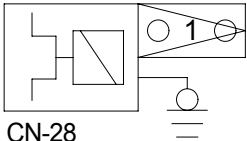
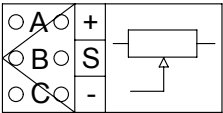
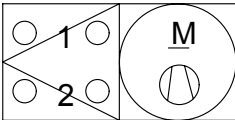
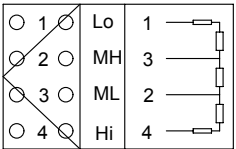
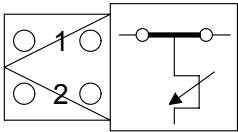
Part name	Symbol	Specification	Check
Alternator	 <p>CN-74</p>	24V 60A	※ Check contact Normal : 0 Ω (For terminal B □1) Normal : 24 ~ 27.5V
Aircon compressor	 <p>CN-28</p>	24V 79W	※ Check contact Normal : 13.4 Ω
Accel dial	 <p>CN-142</p>	-	※ Check resistance Normal : About 5kΩ (For terminal A-C) ※ Check voltage Normal : About 5V (For terminal A-C) : 2 ~ 4.5V (For terminal C-B)
Blower motor		24V 9.5A	※ Check resistance 2.5 Ω (For terminal 1-2)
Aircon resistor		-	※ Check resistance 1.12 Ω (For terminal 4-2) 2.07 Ω (For terminal 2-3) 3.17 Ω (For terminal 3-1)
Duct sensor (Switch)		1°C OFF 4°C ON	※ Check resistance : 0 Ω (For terminal 1-2, the atmosphere temp : over 4°C)

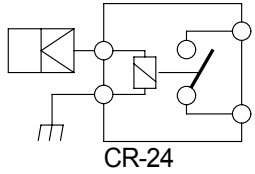
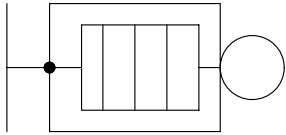
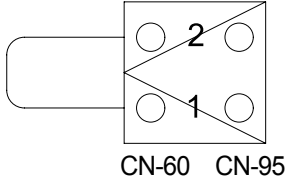
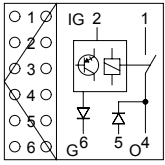
Part name	Symbol	Specification	Check
Preheater relay	 <p>CR-24</p>	24V 200A	※ Check contact Normal : 0.94 Ω (For terminal 1-GND)
Preheater		24V 200A	※ check resistance : 0.25 ~ 0.12 Ω
Fusible link	 <p>CN-60 CN-95</p>	60A	※ Check disconnection Normal : 0 Ω (Connect ring terminal and check resist between terminal 1 and 2)
Relay timer	 <p>CR-50</p>	24V 70A	-

## GROUP 4 CONNECTORS

### 1. CONNECTOR DESTINATION

Connector number	Type	No. of pin	Destination	Connector part No.	
				Female	Male
CN-2	KET	15	Engine rear harness	2-85262-1	368301-1
CN-3	AMP	8	Engine harness	S816-008002	S816-108002
CN-4	AMP	8	Console LH wire harness	S816-008002	S816-108002
CN-5	AMP	12	RH side harness	2-85262-1	368301-1
CN-6	AMP	12	RH side harness	S816-012002	S816-112002
CN-7	AMP	6	Console RH wire harness	S816-006002	S816-106002
CN-8	AMP	12	Console RH wire harness	S816-012002	S816-112002
CN-9	AMP	8	Console RH wire harness	S816-008002	S816-108002
CN-10	DEUTSCH	12	Cab harness	DT06-12S	DT06-12P
CN-11	DEUTSCH	8	Aircon harness	DT06-8S	DT04-08P
CN-12	DEUTSCH	2	Work lamp harness	DT06-2S-EP06	DT04-2P-E004
CN-15	KET	2	2pcs auto idle pressure	S814-002100	S814-102100
CN-17	DEUTSCH	8	Wiper harness	DT06-8S	DT04-8P
CN-19	AMP	2	Emergency MCU connector	S816-002002	-
CN-20	MOLEX	2	Horn	36825-0211	-
CN-21	AMP	6	Wiper motor	925276-0	-
CN-22	KET	2	Washer tank	MG640605	-
CN-23	KET	2	LH speaker	MG610070	-
CN-24	KET	2	RH speaker	MG610070	-
CN-25	MOLEX	2	Horn	36825-0211	-
CN-27	AMP	14	Cassette radio	173852	-
CN-28	MWP	1	Air-con compressor	MWP01F-B	-
CN-29	KET	2	Receiver dryer	MG640795	-
CN-36	DEUTSCH	3	Fuse box	21N8-20041	-
CN-45	RING TERM	-	Start motor B <sup>+</sup>	ST710264-2	-
CN-47	AMP	2	Resistor	S810-002202	S810-102202
CN-48	RING TERM	2	Hour meter	GP890469	-
CN-50	AMP	36	MCU	3441110	-
CN-51	AMP	36	MCU	3441110	-
CN-56	DEUTSCH	4	Cluster	-	DT04-4P-E004
CN-60	YAZAKI	2	Fusible link	7123-4125-50	7122-4125-50
CN-66	DEUTSCH	2	Breaker solenoid	DT06-2S-EP06	DT04-2P-E005
CN-68	DEUTSCH	2	Safety solenoid	DT06-2S-EP06	DT04-2P-E005
CN-70	DEUTSCH	2	Travel speed solenoid	DT06-2S-EP06	-
CN-74	RING-TERM	1	Alternator "1" term	S820-105000	-
CN-75	Econoseal J	2	EPPR valve	S816-002002	-
CN-76	DEUTSCH	6	DC motor	DT06-6S-EP06	-
CN-79	-	3	Fuel cut-off	S810-002201	-
CN-92	AMP	1	Emergency engine starting connector	S814-101100	S814-001100



Connector number	Type	No. of pin	Destination	Connector part No.	
				Female	Male
CN-95	KET	2	Fusible link	S813-030201	S813-130200
CN-126	DEUTSCH	4	RS232 connector	DT06-4S-EP06	DT04-4P-E005
CN-137	DEUTSCH	2	Max flow solenoid valve	DT06-2S-EP06	-
CN-141	AMP	13	Wiper motor control unit	172498-1	-
CN-142	DEUTSCH	3	Accel dial	DT06-3S-P012	-
CN-143	AMP	2	Cassette radio(with remocon)	S816-002002	-
CN-144	AMP	12	Remocon-cassette radio	174045-2	-
CN-147	-	2	Fuel heater	1530-0027	-
CN-248	-	2	Fan	S816-002002	S816-102002
RELAY					
CR-1	RING TERM	1	Battery relay	S820-104002	-
CR-2	-	5	Horn relay	-	-
CR-5	-	5	Safety relay	-	-
CR-7	-	5	Ac comp relay	-	-
CR-23	KET	2	Start relay	S814-002001	S814-102001
CR-24	RING TERM	1	Pre-heater relay	S822-014000	-
CR-35	-	5	Power relay	-	-
CR-36	-	5	Pre-heat relay	-	-
CR-46	-	4	Fuel warmer	S810-004202	-
CR-50	KET	6	Relay timer	MG610049-5	-
SWITCH					
CS-1	SHUR	1	Door switch	S822-014004	-
CS-2	-	6	Start key switch	S814-006000	S814-106000
CS-3	SWF	10	Wiper & washer switch	SWF593757	-
CS-4	DEUTSCH	3	Safety switch	DT06-3S-P012	DT04-3P-E004
CS-5	DEUTSCH	2	Horn switch	DT06-2S-EP06	DT04-2P-E004
CS-19	DEUTSCH	2	One touch decel	DT06-2S-EP06	DT04-2P-E004
CS-20	AMP	1	Safety switch	S822-014002	-
CS-21	SWF	10	Main light switch	SWF593757	-
CS-23	SWF	10	Beacon lamp switch	SWF593757	-
CS-24	SWF	10	Cab light switch	SWF593757	-
CS-26	DEUTSCH	2	Breaker switch	DT06-2S-P012	DT04-2P-E004
CS-27	SWF	10	Breaker switch	SWF593757	-
CS-53	SHUR	1	Wiper cut switch	S822-014002	-
CS-54	SWF	10	Spare switch	SWF593757	-
CS-99	SWF	10	Spare switch	SWF593757	-
CS-101	SWF	10	Fan switch	SWF593757	-
LAMP					
CL-1	KET	2	Cab room lamp	MG610392	-
CL-2	AMP	1	Cigar light	S822-014002	-
CL-4	DEUTSCH	2	Head lamp	DT06-2S-EP06	DT04-2P-E005
CL-5	DEUTSCH	2	Work lamp-LH	DT06-2S-EP06	DT04-2P-E005

Connector number	Type	No. of pin	Destination	Connector part No.	
				Female	Male
CL-6	DEUTSCH	2	Work lamp-RH	DT06-2S-EP06	DT04-2P-E005
CL-7	SHUR	1	Beacon lamp	S822-014004	S822-114004
CL-8	DEUTSCH	2	Cabin light-LH	DT06-2S-EP06	DT04-2P-E005
CL-9	DEUTSCH	2	Cabin light-RH	DT06-2S-EP06	DT04-2P-E005
SENDER					
CD-1	AMP	2	Hydraulic oil temp sender	85202-1	-
CD-2	DEUTSCH	2	Fuel sender	DT06-2S-EP06	DT04-2P-E005
CD-6	KET	3	Travel pressure switch	MG640795	-
CD-7	KET	3	Working pressure switch	MG640795	-
CD-8	AMP	2	Water temp sender	85202-1	-
CD-10	RING TERM	1	Air cleaner switch	GP690469	-
CD-17	-	2	Tacho sensor	-	S818-120221
CD-18	RING TERM	1	Engine oil pressure switch	S820-104000	-
DIODE					
DO-1	AMP	2	-	21EA-50550	-
DO-2	AMP	2	-	21EA-50550	-
DO-5	AMP	2	-	21EA-50570	-

## 2. CONNECTION TABLE FOR CONNECTORS

### 1) PA TYPE CONNECTOR

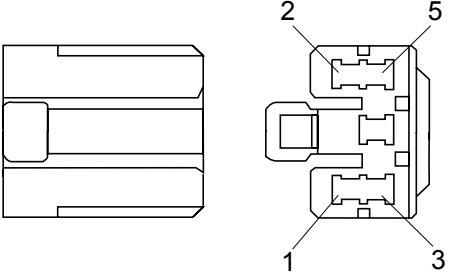
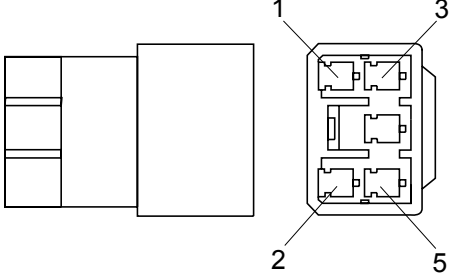
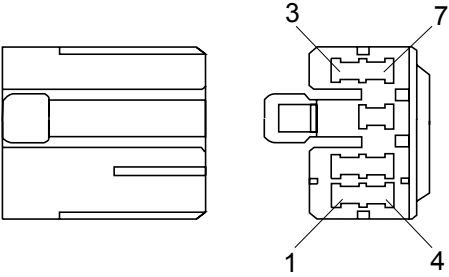
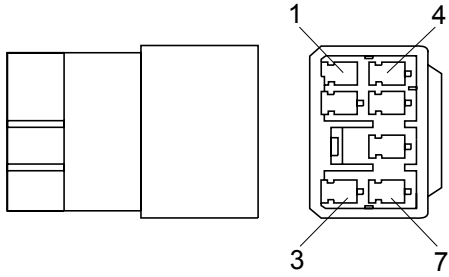
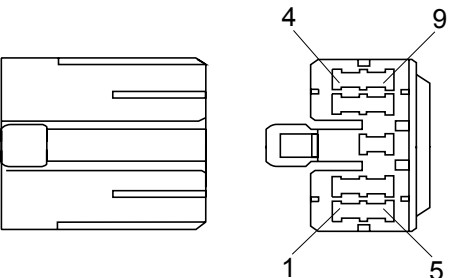
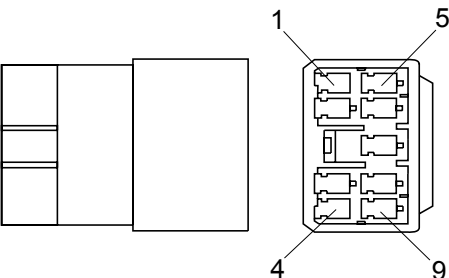
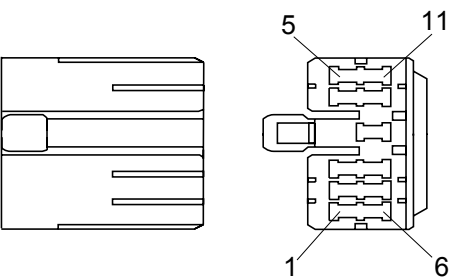
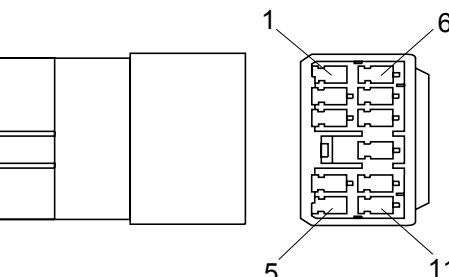
No. of pin	Receptacle connector(Female)	Plug connector(Male)
5	 <p style="text-align: center;">S811-005002</p>	 <p style="text-align: center;">S811-105002</p>
7	 <p style="text-align: center;">S811-007002</p>	 <p style="text-align: center;">S811-107002</p>
9	 <p style="text-align: center;">S811-009002</p>	 <p style="text-align: center;">3S811-109002</p>
11	 <p style="text-align: center;">S811-011002</p>	 <p style="text-align: center;">S811-111002</p>

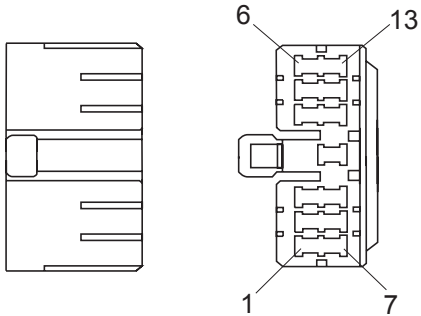
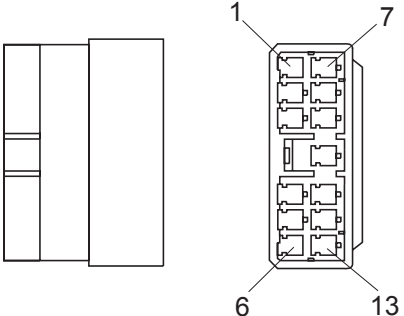
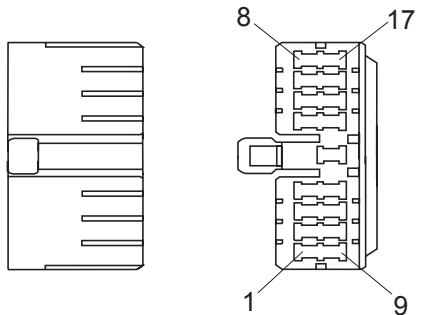
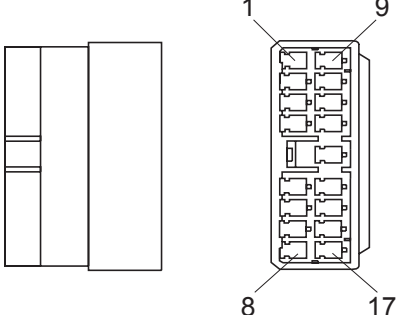
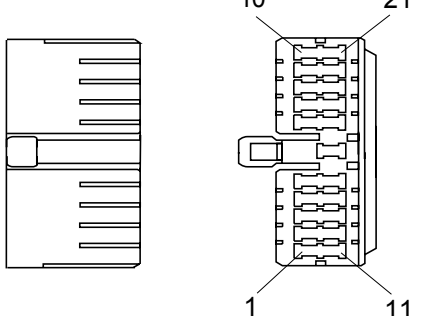
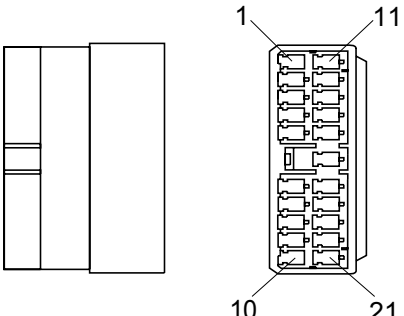
No. of pin	Receptacle connector(Female)	Plug connector(Male)
13	 <p data-bbox="689 629 839 660">S811-013002</p>	 <p data-bbox="1246 629 1396 660">S811-113002</p>
17	 <p data-bbox="689 1032 839 1064">S811-017002</p>	 <p data-bbox="1246 1032 1396 1064">S811-117002</p>
21	 <p data-bbox="689 1435 839 1467">S811-021002</p>	 <p data-bbox="1246 1435 1396 1467">S811-121002</p>

## 2) J TYPE CONNECTOR

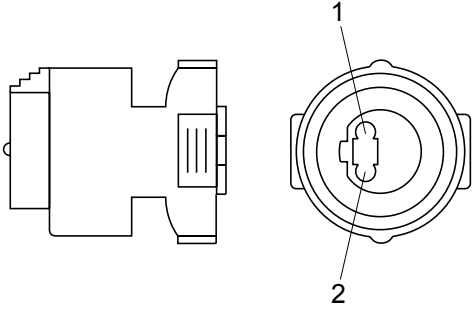
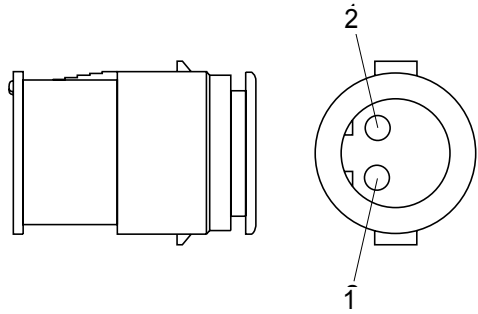
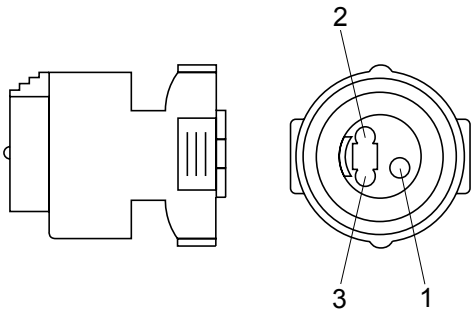
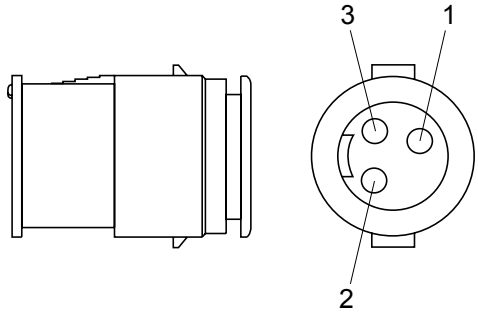
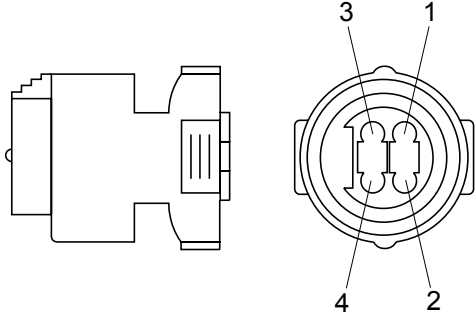
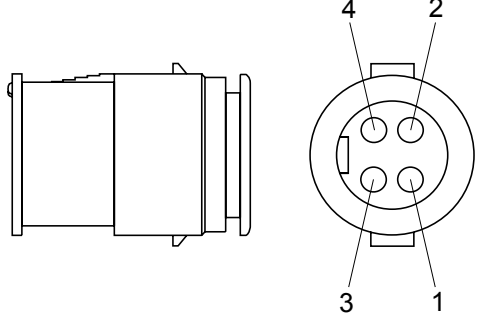
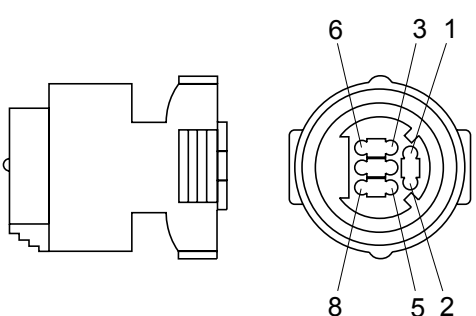
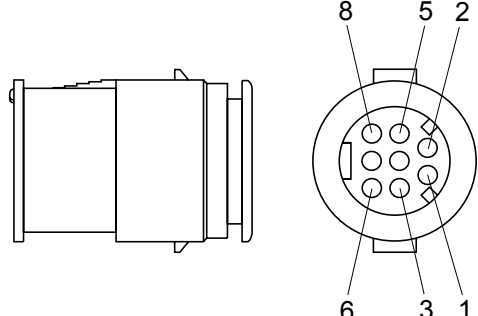
No. of pin	Receptacle connector(Female)	Plug connector(Male)
2	 <p style="text-align: center;">S816-002001</p>	 <p style="text-align: center;">S816-102001</p>
3	 <p style="text-align: center;">S816-003001</p>	 <p style="text-align: center;">S816-103001</p>
4	 <p style="text-align: center;">S816-004001</p>	 <p style="text-align: center;">S816-104001</p>
8	 <p style="text-align: center;">S816-008001</p>	 <p style="text-align: center;">S816-108001</p>

### 3) SWP TYPE CONNECTOR

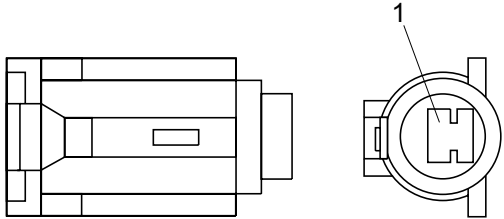
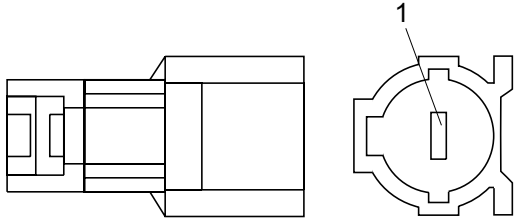
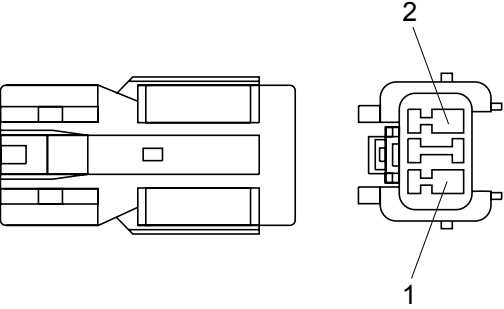
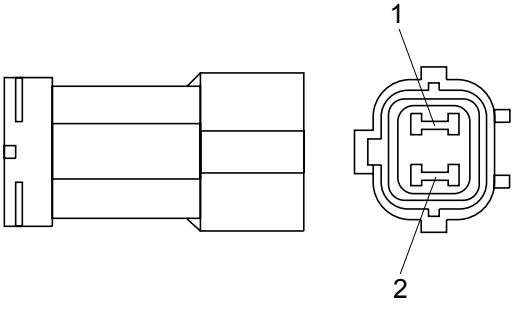
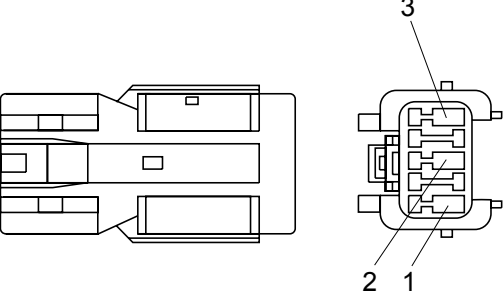
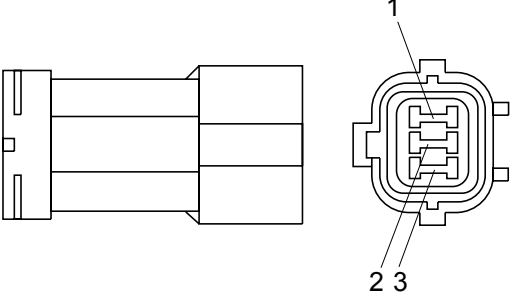
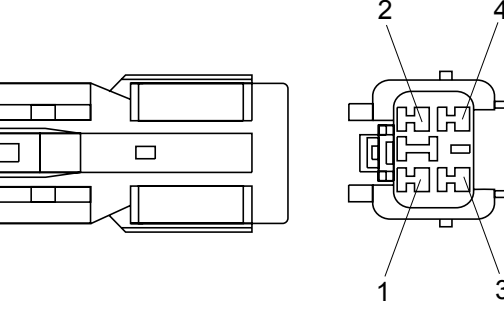
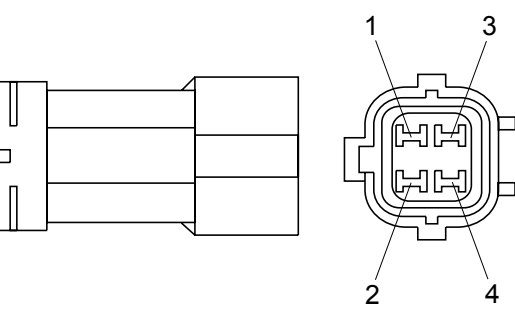
No. of pin	Receptacle connector(Female)	Plug connector(Male)
1	 <p data-bbox="687 674 837 705">S814-001000</p>	 <p data-bbox="1246 674 1396 705">S814-101000</p>
2	 <p data-bbox="687 1077 837 1108">S814-002000</p>	 <p data-bbox="1246 1077 1396 1108">S814-102000</p>
3	 <p data-bbox="687 1487 837 1518">S814-003000</p>	 <p data-bbox="1246 1487 1396 1518">S814-103000</p>
4	 <p data-bbox="687 1892 837 1924">S814-004000</p>	 <p data-bbox="1246 1892 1396 1924">S814-104000</p>

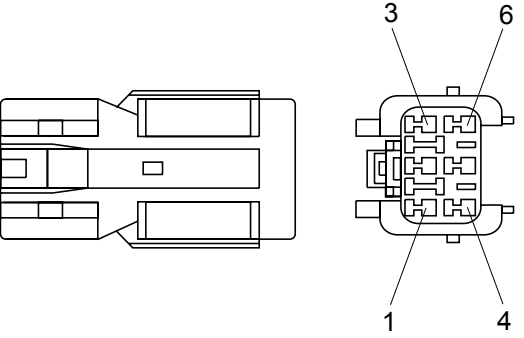
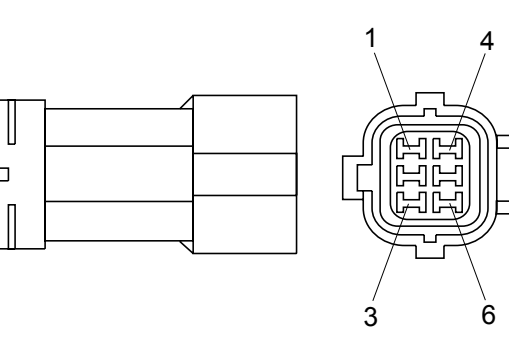
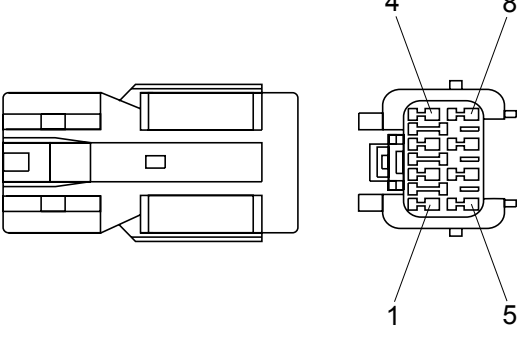
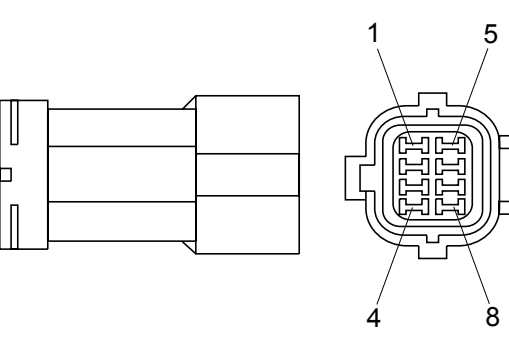
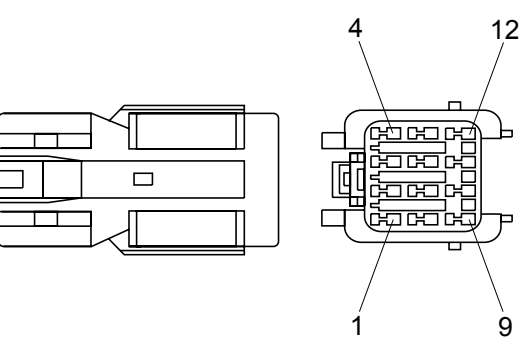
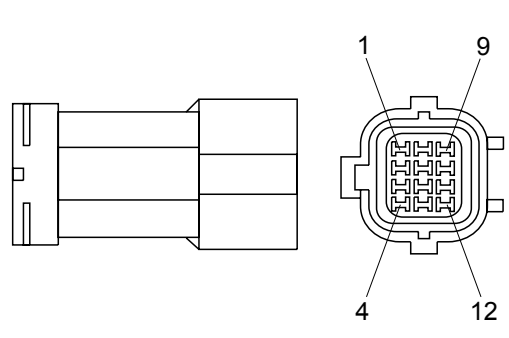
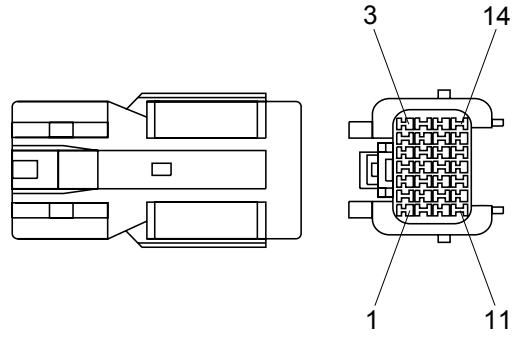
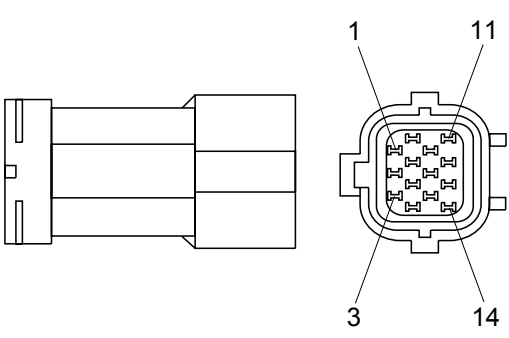
No. of pin	Receptacle connector(Female)	Plug connector(Male)
6	 <p data-bbox="686 627 837 660">S814-006000</p>	 <p data-bbox="1244 627 1396 660">S814-106000</p>
8	 <p data-bbox="686 1041 837 1075">S814-008000</p>	 <p data-bbox="1244 1041 1396 1075">S814-108000</p>
12	 <p data-bbox="686 1444 837 1478">S814-012000</p>	 <p data-bbox="1244 1444 1396 1478">S814-112000</p>
14	 <p data-bbox="686 1848 837 1881">S814-014000</p>	 <p data-bbox="1244 1848 1396 1881">S814-114000</p>

#### 4) CN TYPE CONNECTOR

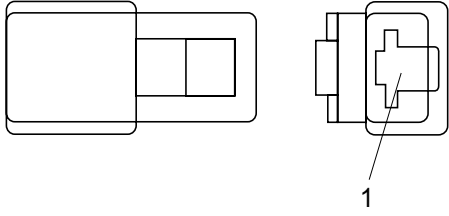
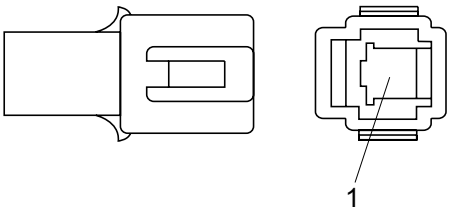
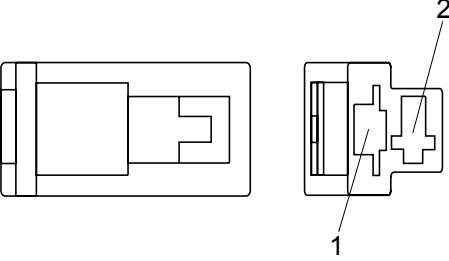
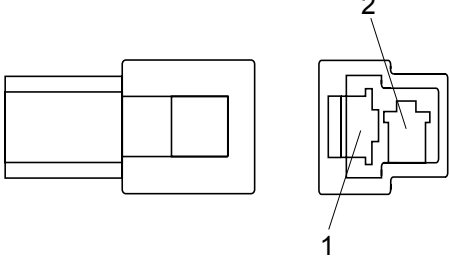
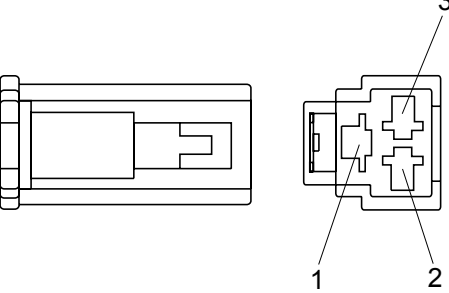
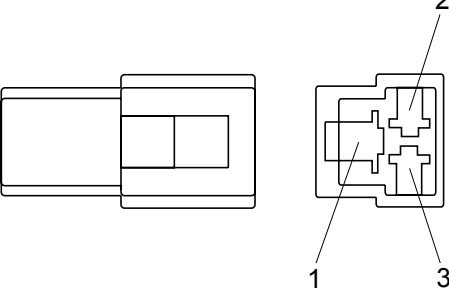
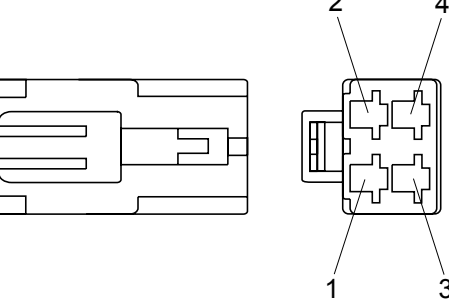
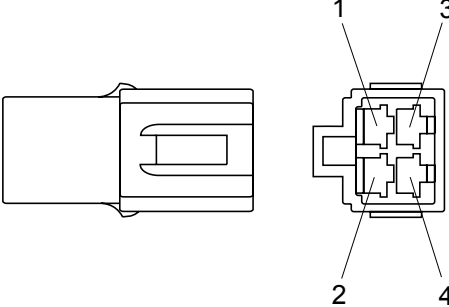
No. of pin	Receptacle connector(Female)	Plug connector(Male)
1	 <p data-bbox="689 676 837 705">S810-001202</p>	 <p data-bbox="1243 676 1391 705">S810-101202</p>
2	 <p data-bbox="689 1079 837 1108">S810-002202</p>	 <p data-bbox="1243 1079 1391 1108">S810-102202</p>
3	 <p data-bbox="689 1482 837 1512">S810-003202</p>	 <p data-bbox="1243 1482 1391 1512">S810-103202</p>
4	 <p data-bbox="689 1899 837 1928">S810-004202</p>	 <p data-bbox="1243 1899 1391 1928">S810-104202</p>

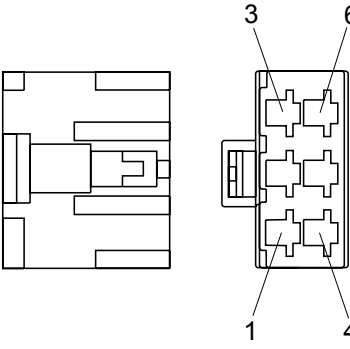
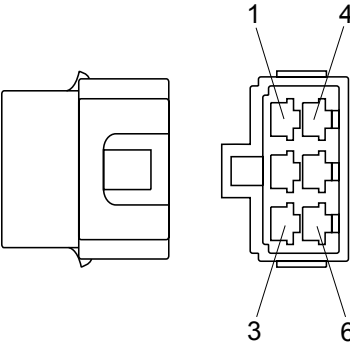
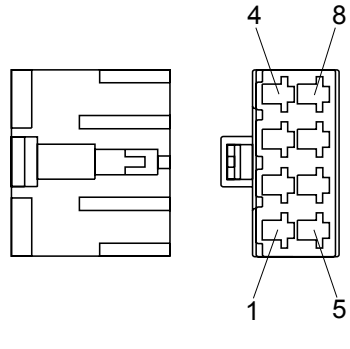
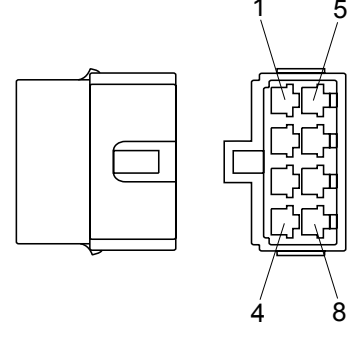

No. of pin	Receptacle connector(Female)	Plug connector(Male)
6	 <p style="text-align: center;">S810-006202</p>	 <p style="text-align: center;">S810-106202</p>
8	 <p style="text-align: center;">S810-008202</p>	 <p style="text-align: center;">S810-108202</p>

### 5) 375 FASTEN TYPE CONNECTOR

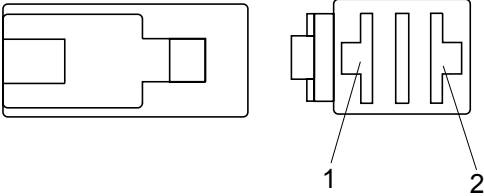
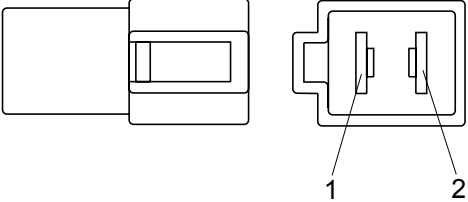
No. of pin	Receptacle connector(Female)	Plug connector(Male)
2	 <p style="text-align: center;">S810-002402</p>	 <p style="text-align: center;">S810-102402</p>

### 6) AMP ECONOSEAL CONNECTOR

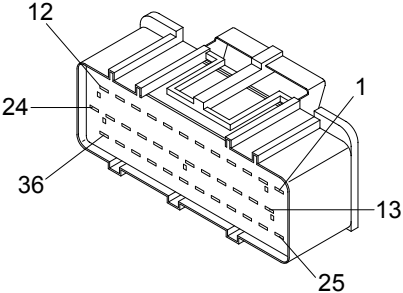
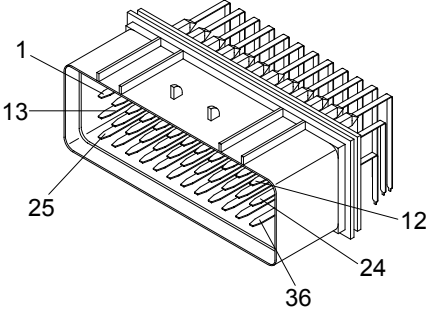
No. of pin	Receptacle connector(Female)	Plug connector(Male)
36	 <p style="text-align: center;">344111-1</p>	 <p style="text-align: center;">344108-1</p>

### 7) AMP TIMER CONNECTOR

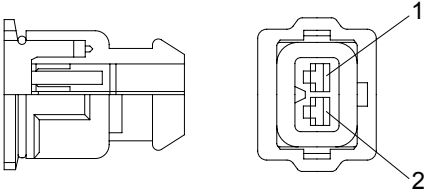
No. of pin	Receptacle connector(Female)	Plug connector(Male)
2	 <p style="text-align: center;">85202-1</p>	

### 8) AMP 040 MULTILOCK CONNECTOR

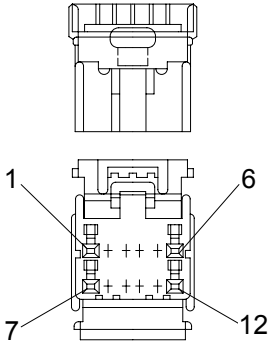
No. of pin	Receptacle connector(Female)	Plug connector(Male)
12	 <p style="text-align: right;">174045-2</p>	

### 9) AMP 070 MULTILOCK CONNECTOR

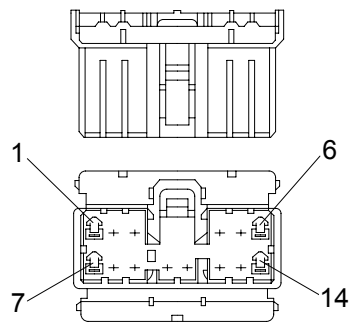
No. of pin	Receptacle connector(Female)	Plug connector(Male)
14	 <p style="text-align: right;">173852</p>	

### 10) AMP FASTIN - FASTON CONNECTOR

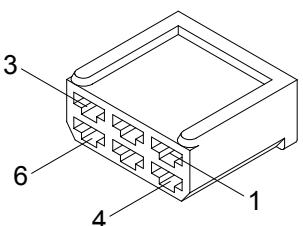
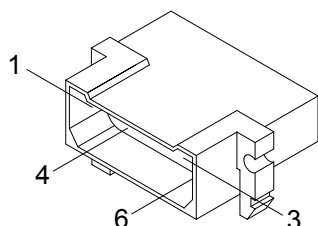
No. of pin	Receptacle connector(Female)	Plug connector(Male)
6	 <p style="text-align: right;">925276-0</p>	 <p style="text-align: right;">480003-9</p>

**11)KET 090 CONNECTOR**

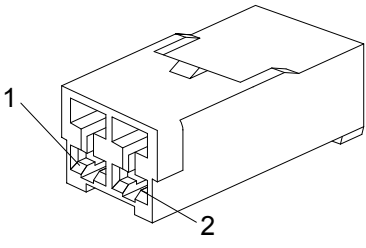
No. of pin	Receptacle connector(Female)	Plug connector(Male)
2	 <p style="text-align: right;">MG610070</p>	

**12)KET 090 WP CONNECTORS**

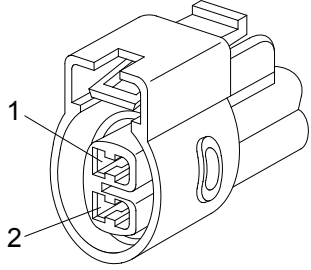
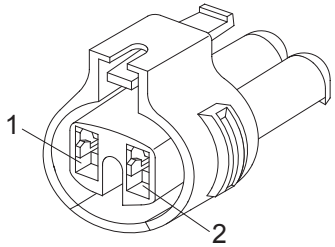
No. of pin	Receptacle connector(Female)	Plug connector(Male)
2	 <p style="text-align: right;">MG640605</p>	
2	 <p style="text-align: right;">MG640795</p>	

### 13)KET SDL CONNECTOR

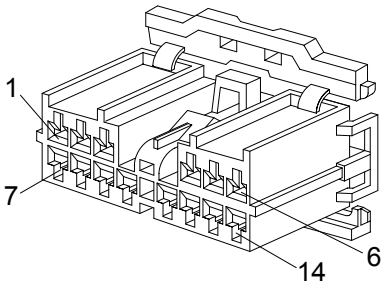
No. of pin	Receptacle connector(Female)	Plug connector(Male)
14	 <p data-bbox="715 674 837 705">MG610406</p>	

# 14) DEUTSCH DT CONNECTORS

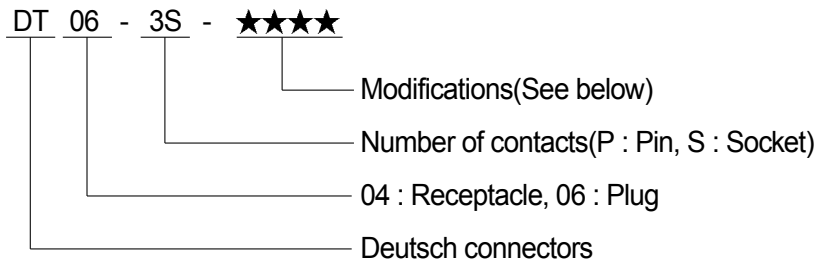

※ Modification

E003 : Standard end cap - gray

E004 : Color of connector to be black

E005 : Combination - E004 & E003

EP04 : End cap

EP06 : Combination P012 & EP04

P012 : Front seal enhancement - connectors color to black for 2, 3, 4 & 6pin

No. of pin	Receptacle connector(Female)	Plug connector(Male)
2	<p>DT06-2S</p>	<p>DT04-2P</p>
3	<p>DT06-3S</p>	<p>DT04-3P</p>
4	<p>DT06-4S</p>	<p>DT04-4P</p>

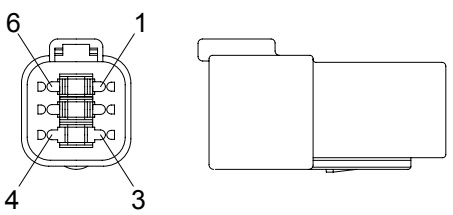
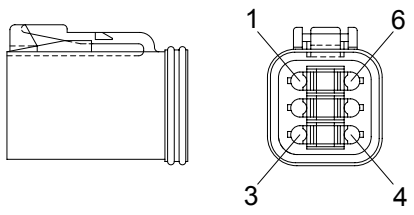
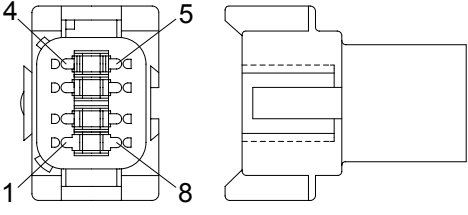
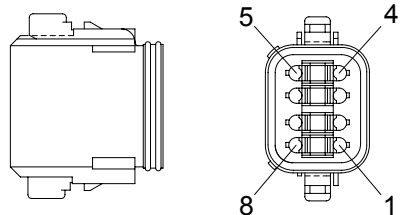
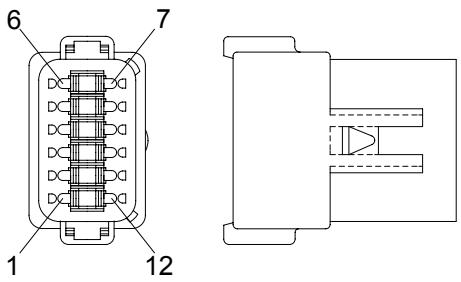
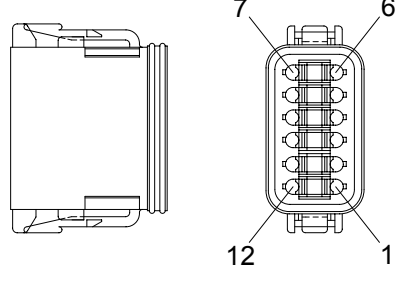
No. of pin	Receptacle connector(Female)	Plug connector(Male)
6	 <p style="text-align: right;">DT06-6S</p>	 <p style="text-align: right;">DT04-6P</p>
8	 <p style="text-align: right;">DT06-8S</p>	 <p style="text-align: right;">DT04-8P</p>
12	 <p style="text-align: right;">DT06-12S</p>	 <p style="text-align: right;">DT04-12P</p>

**15) MOLEX 2CKTS CONNECTOR**

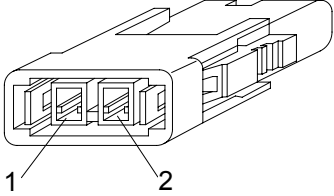
No. of pin	Receptacle connector(Female)	Plug connector(Male)
2	 <p data-bbox="703 674 839 703">35215-0200</p>	

**16) ITT SWF CONNECTOR**

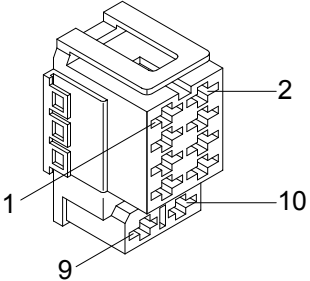
No. of pin	Receptacle connector(Female)	Plug connector(Male)
10	 <p data-bbox="699 1279 839 1308">SWF593757</p>	

**17) MWP NMWP CONNECTOR**

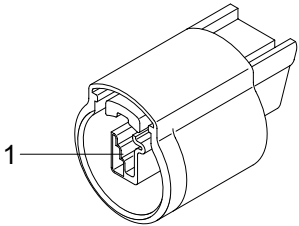
No. of pin	Receptacle connector(Female)	Plug connector(Male)
1	 <p data-bbox="691 1883 839 1912">NMWP01F-B</p>	

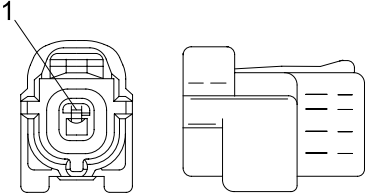
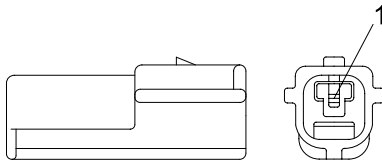
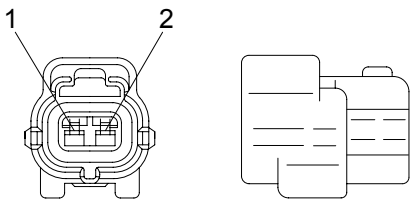
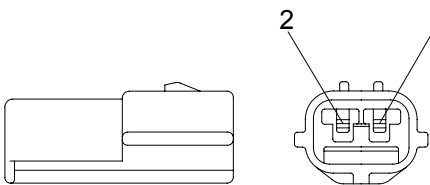
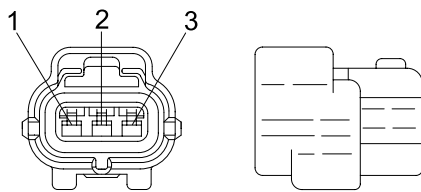
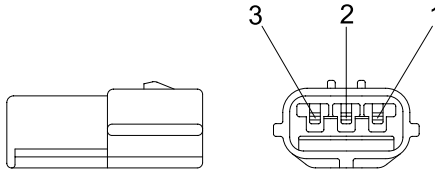
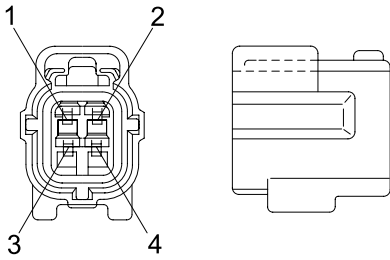
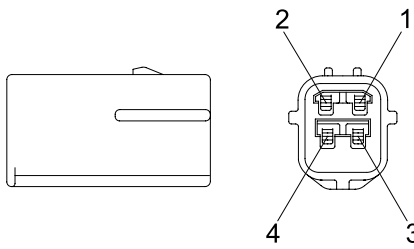

**18)ECONOSEAL J TYPE CONNECTORS**

No. of pin	Receptacle connector(Female)	Plug connector(Male)
1	 <p style="text-align: center;">S816-001002</p>	 <p style="text-align: center;">S816-101002</p>
2	 <p style="text-align: center;">S816-002002</p>	 <p style="text-align: center;">S816-102002</p>
3	 <p style="text-align: center;">S816-003002</p>	 <p style="text-align: center;">S816-103002</p>
4	 <p style="text-align: center;">S816-004002</p>	 <p style="text-align: center;">S816-104002</p>

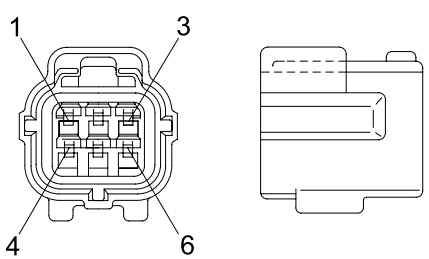
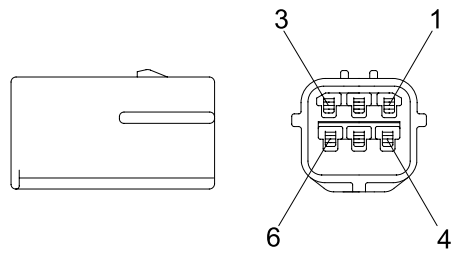
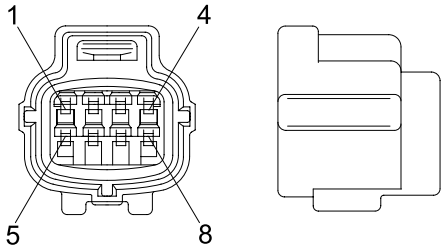
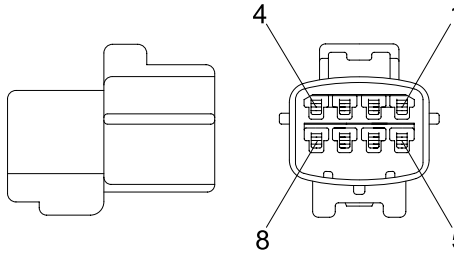
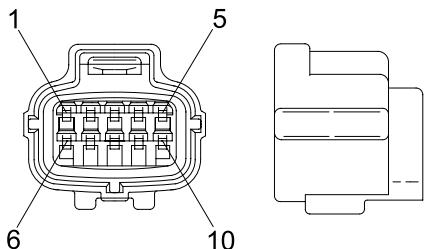
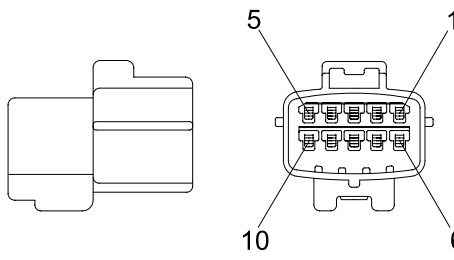
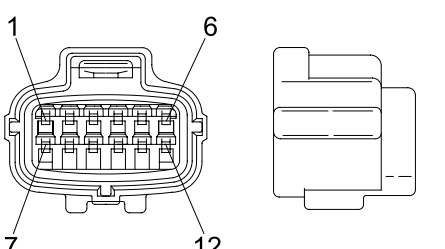
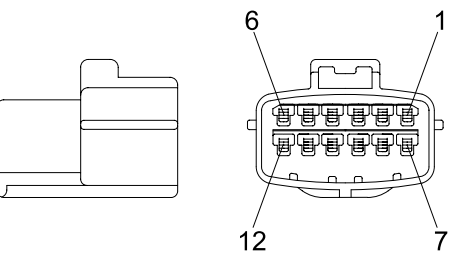
No. of pin	Receptacle connector(Female)	Plug connector(Male)
6	 <p style="text-align: center;">S816-006002</p>	 <p style="text-align: center;">S816-106002</p>
8	 <p style="text-align: center;">S816-008002</p>	 <p style="text-align: center;">S816-108002</p>
10	 <p style="text-align: center;">S816-010002</p>	 <p style="text-align: center;">S816-110002</p>
12	 <p style="text-align: center;">S816-012002</p>	 <p style="text-align: center;">S816-112002</p>

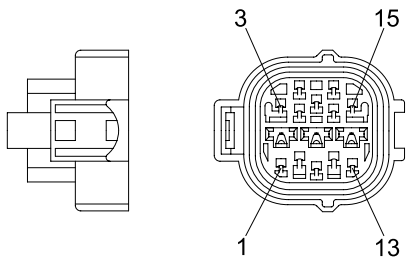
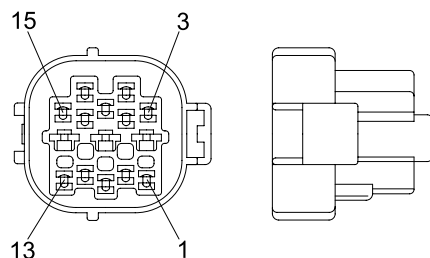
No. of pin	Receptacle connector(Female)	Plug connector(Male)
15	 <p data-bbox="730 629 836 658">368301-1</p>	 <p data-bbox="1278 629 1383 658">2-85262-1</p>

### 19) METRI-PACK TYPE CONNECTOR

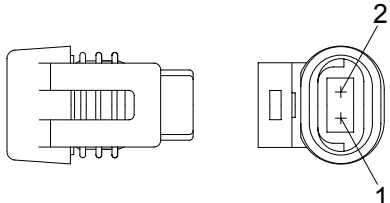
No. of pin	Receptacle connector(Female)	Plug connector(Male)
2	 <p data-bbox="730 1234 836 1263">12040753</p>	

### 20) DEUTSCH HD30 CONNECTOR

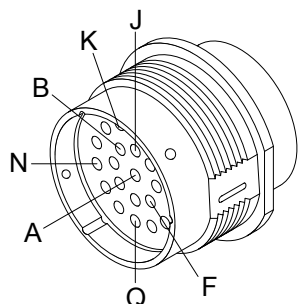
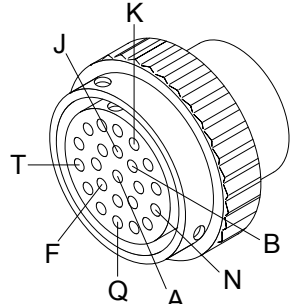
No. of pin	Receptacle connector(Female)	Plug connector(Male)
23	 <p data-bbox="667 1839 836 1868">HD36-24-23SN</p>	 <p data-bbox="1225 1839 1394 1868">HD34-24-23PN</p>