

# GROUP 4 HYDRAULIC SYSTEM

## HYDRAULIC COMPONENTS MOUNTING 1

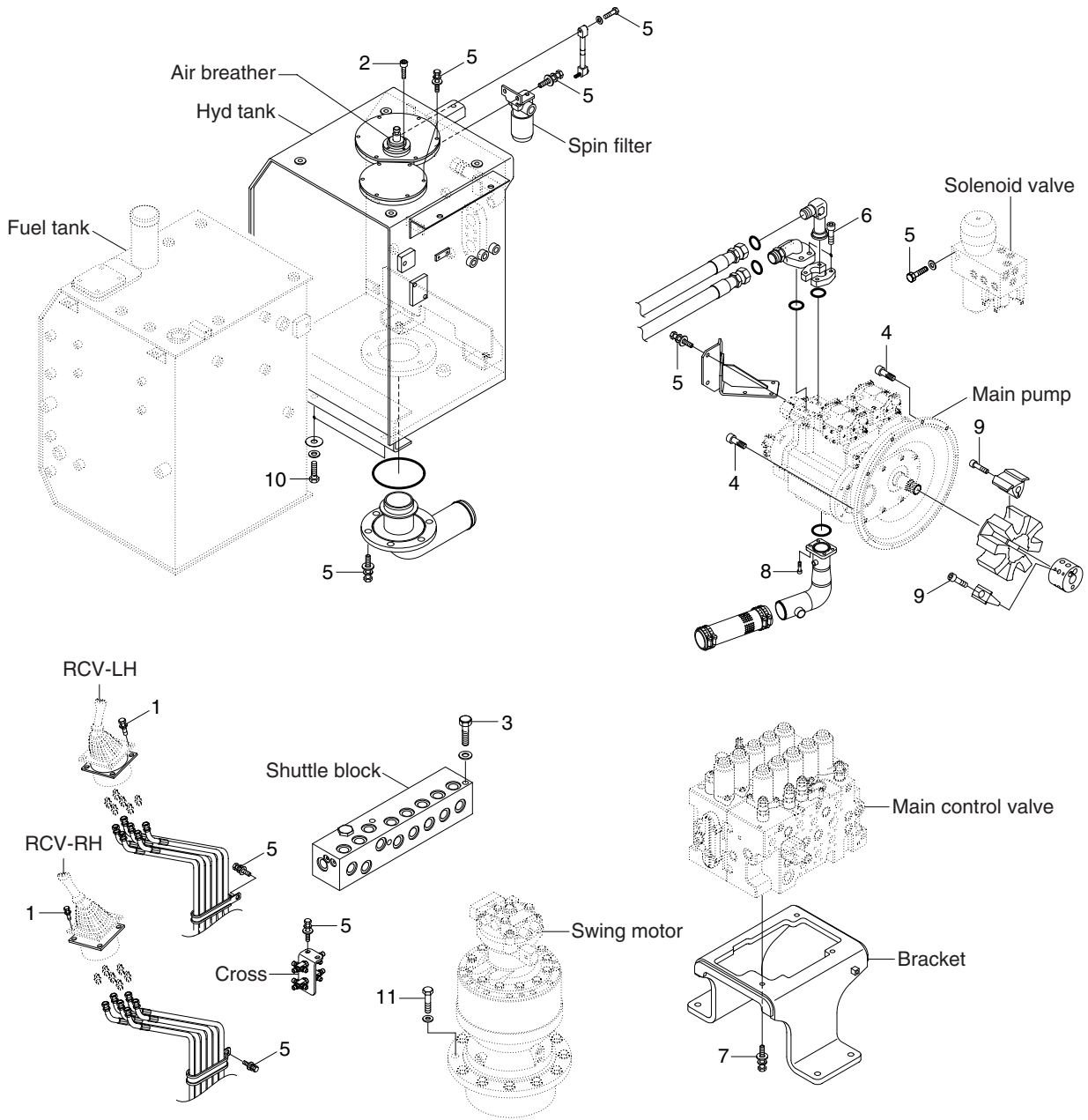

210N99CM05

### · Tightening torque

Item	Size	kgf · m	lbf · ft
1	M 6×1.0	1.05±0.2	7.6±1.45
2	M 6×1.0	1.44±0.3	10.4±2.2
3	M 8×1.25	2.5±0.5	18.1±3.6
4	M10×1.5	4.8±0.3	34.7±2.2
5	M10×1.5	6.9±1.4	49.9±10.1
6	M10×1.5	8.27±1.7	59.8±12.3

Item	Size	kgf · m	lbf · ft
7	M12×1.75	12.3±1.3	89±9.4
8	M12×1.75	14.7±2.2	106±15.9
9	M18×2.5	32±1.0	231±7.2
10	M20×2.5	46±5.1	333±36.9
11	M20×2.5	57.9±8.7	419±62.9

# HYDRAULIC COMPONENTS MOUNTING 2

Double acting attachment piping

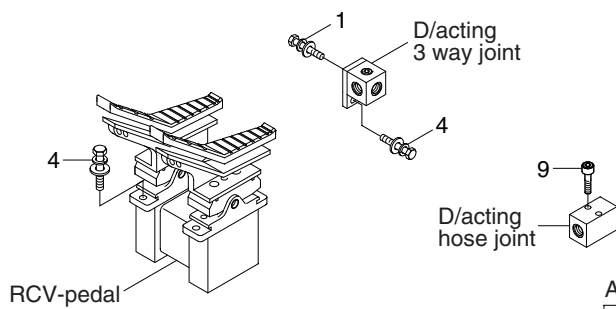
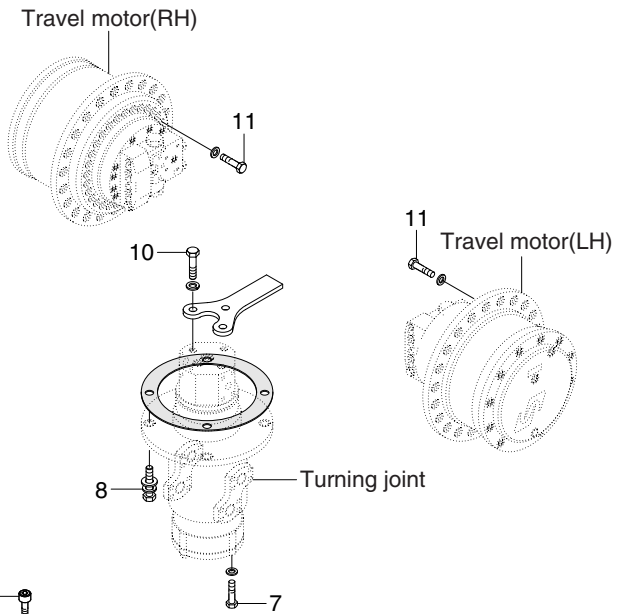
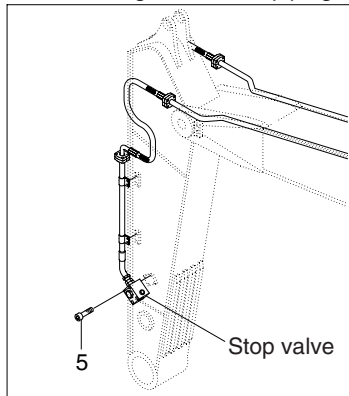

Arm safety lock system

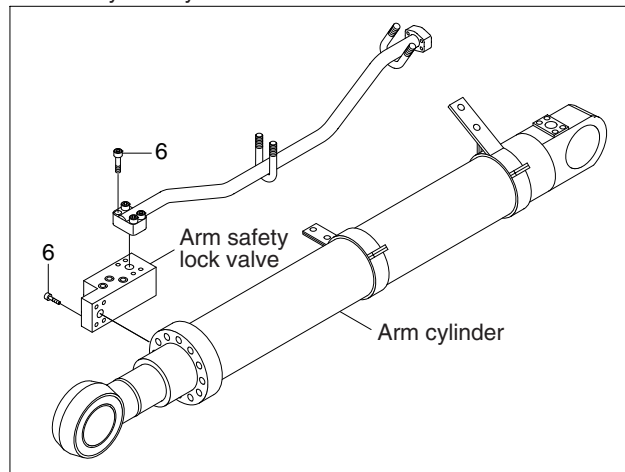

D/acting single pedal

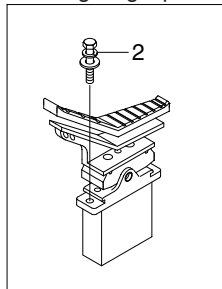

Boom safety lock system

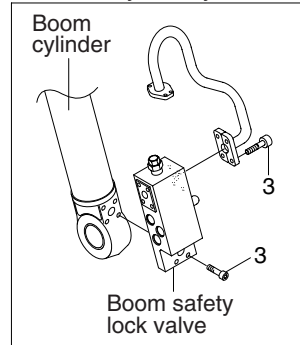

21099CM06

• Tightening torque

Item	Size	kgf · m	lbf · ft
1	M 8×1.25	2.5±0.5	18.1±3.6
2	M 8×1.25	4.05±0.8	29.3±5.8
3	M10×1.5	5.4±0.5	39±3.6
4	M10×1.5	6.9±1.4	49.9±10.1
5	M10×1.5	8.27±1.7	59.8±12.3
6	M12×1.75	9.4±1.0	68±7.2

Item	Size	kgf · m	lbf · ft
7	M12×1.75	12.3±1.3	89±9.4
8	M12×1.75	12.8±3.0	92.6±21.7
9	M12×1.75	14.7±2.2	106±15.9
10	M14×2.0	19.6±2.9	142±21.0
11	M16×2.0	23.0±2.5	166±18.1

# HYDRAULIC COMPONENTS MOUNTING 3

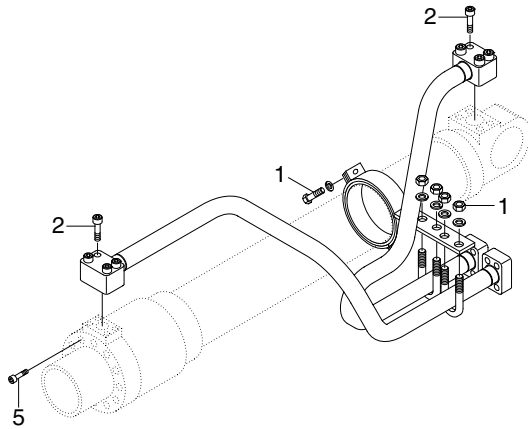

BOOM CYLINDER

Solenoid valve

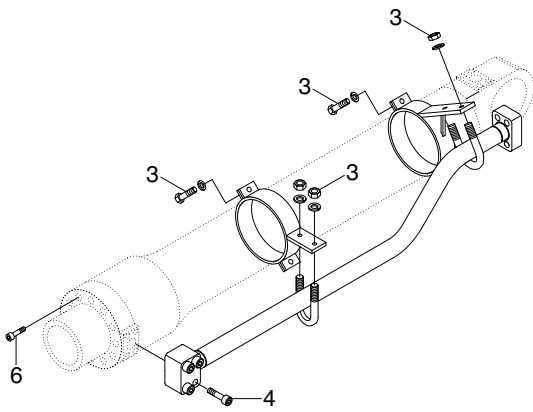
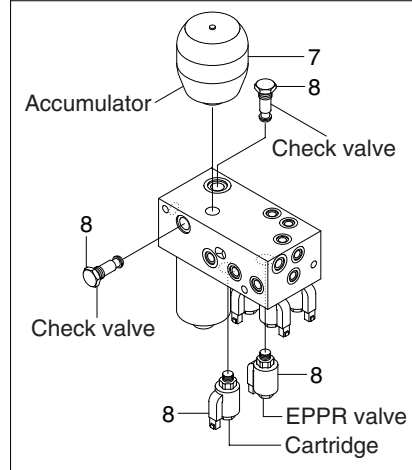

ARM CYLINDER

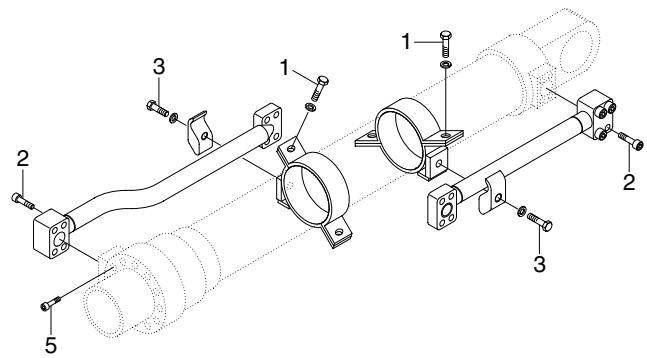

BUCKET CYLINDER

21099CM07

· Tightening torque

Item	Size	kgf · m	lbf · ft
1	M10×1.5	3.2±0.3	23.1±2.2
2	M10×1.5	5.4±0.5	39.1±3.6
3	M12×1.75	5.5±0.6	39.8±4.3
4	M12×1.75	9.4±1.0	68.0±7.2

Item	Size	kgf · m	lbf · ft
5	M16×2.0	23±2.0	166±14.5
6	M18×2.5	32±3.0	232±21.7
7	Accumulator	5.6±0.5	40.5±3.6
8	Check valve	2.5±0.5	18±3.6