

SECTION 4 ELECTRICAL SYSTEM

Group 1 Component Location	4-1
Group 2 Electrical Circuit	4-3
Group 3 Electrical Component Specification	4-21
Group 4 Connectors	4-29

SECTION 4 ELECTRICAL SYSTEM

GROUP 1 COMPONENT LOCATION

1. LOCATION 1

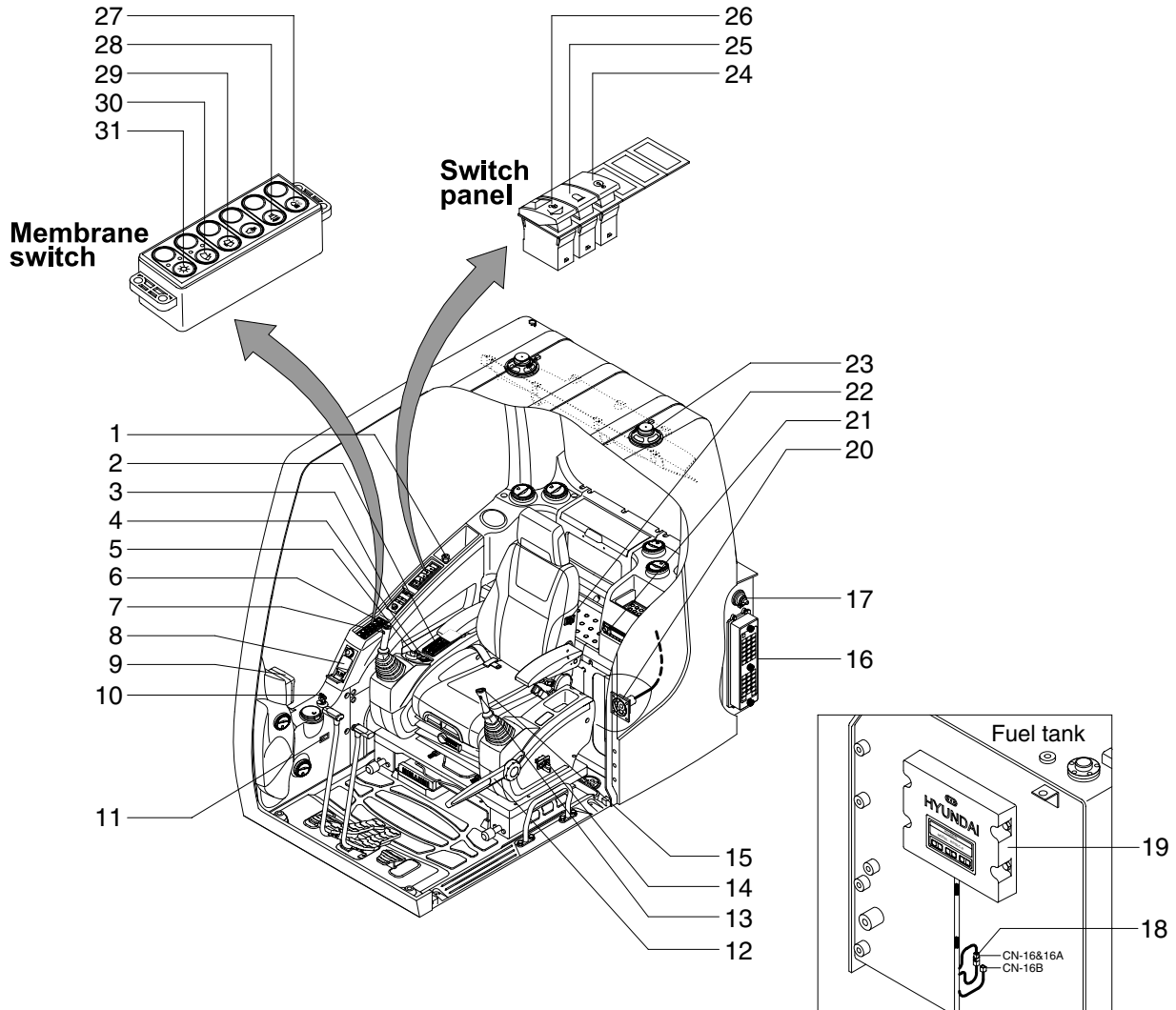

210N94EL01

- | | | |
|----------------------------|---------------------------------|------------------------|
| 1 Cigar lighter | 12 Safety lever | 23 Speaker |
| 2 Air conditioner switch | 13 Power max switch | 24 Overload switch |
| 3 Remote controller | 14 Emergency engine stop switch | 25 Beacon switch |
| 4 Air compressor switch | 15 One touch decel switch | 26 Quick clamp switch |
| 5 Accel dial switch | 16 Fuse & relay box | 27 Cab light switch |
| 6 Horn switch | 17 Master switch | 28 Travel alarm switch |
| 7 Breaker operation switch | 18 Emergency engine connector | 29 Washer switch |
| 8 Handsfree | 19 Machine control unit | 30 Wiper switch |
| 9 Cluster | 20 RS232 & J1939 service socket | 31 Main light switch |
| 10 Start switch | 21 Radio & CD/MP3 player | |
| 11 Hour meter | 22 Heated seat switch | |

2. LOCATION 2

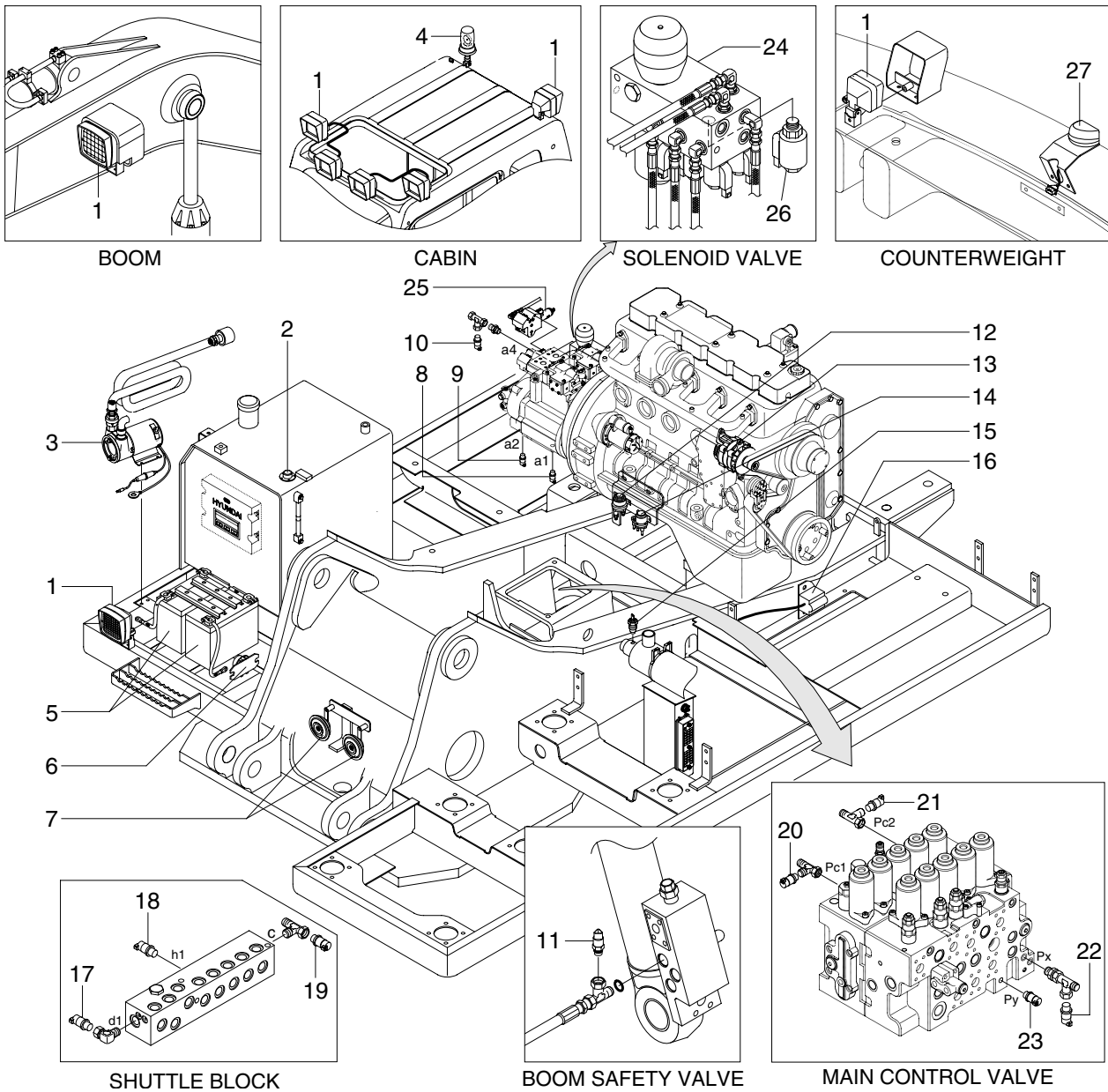

210N94EL02

- | | | |
|----------------------|----------------------------------|--------------------------------|
| 1 Lamp | 10 EPPR pressure sensor | 19 Swing pressure sensor |
| 2 Fuel sender | 11 Overload pressure sensor | 20 Posi-nega 1 pressure sensor |
| 3 Fuel filler pump | 12 Start relay | 21 Posi-nega 2 pressure sensor |
| 4 Beacon lamp | 13 Alternator | 22 Attach pressure sensor |
| 5 Battery | 14 Heater relay | 23 Travel pressure sensor |
| 6 Battery relay | 15 Air cleaner switch | 24 Solenoid valve |
| 7 Horn | 16 Travel alarm buzzer | 25 Pump EPPR valve |
| 8 P1 pressure sensor | 17 Arm/Bucket in pressure sensor | 26 Boom priority EPPR valve |
| 9 P2 pressure sensor | 18 Boom up pressure sensor | 27 Rear camera |