

GROUP 3 PILOT CIRCUIT

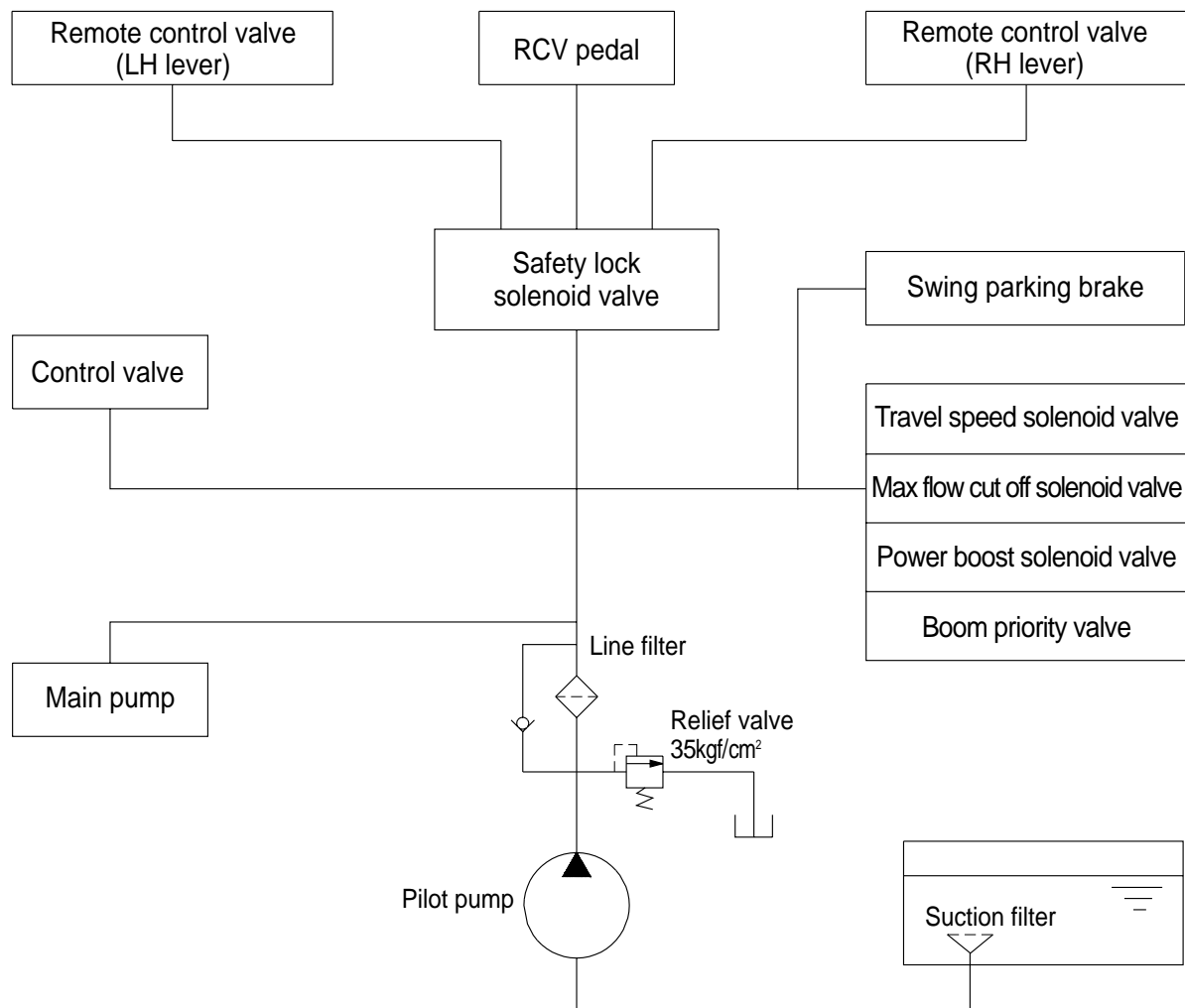

(210-7) 3-05

The pilot circuit consists of suction circuit, delivery circuit and return circuit.

The pilot pump is provided with relief valve, receives the oil from the hydraulic tank through the suction filter.

The discharged oil from the pilot pump flows to the remote control valve through line filter, EPPR valve, solenoid valve assemblies, swing parking brake, main control valve and safety lock solenoid valve.

1. SUCTION, DELIVERY AND RETURN CIRCUIT

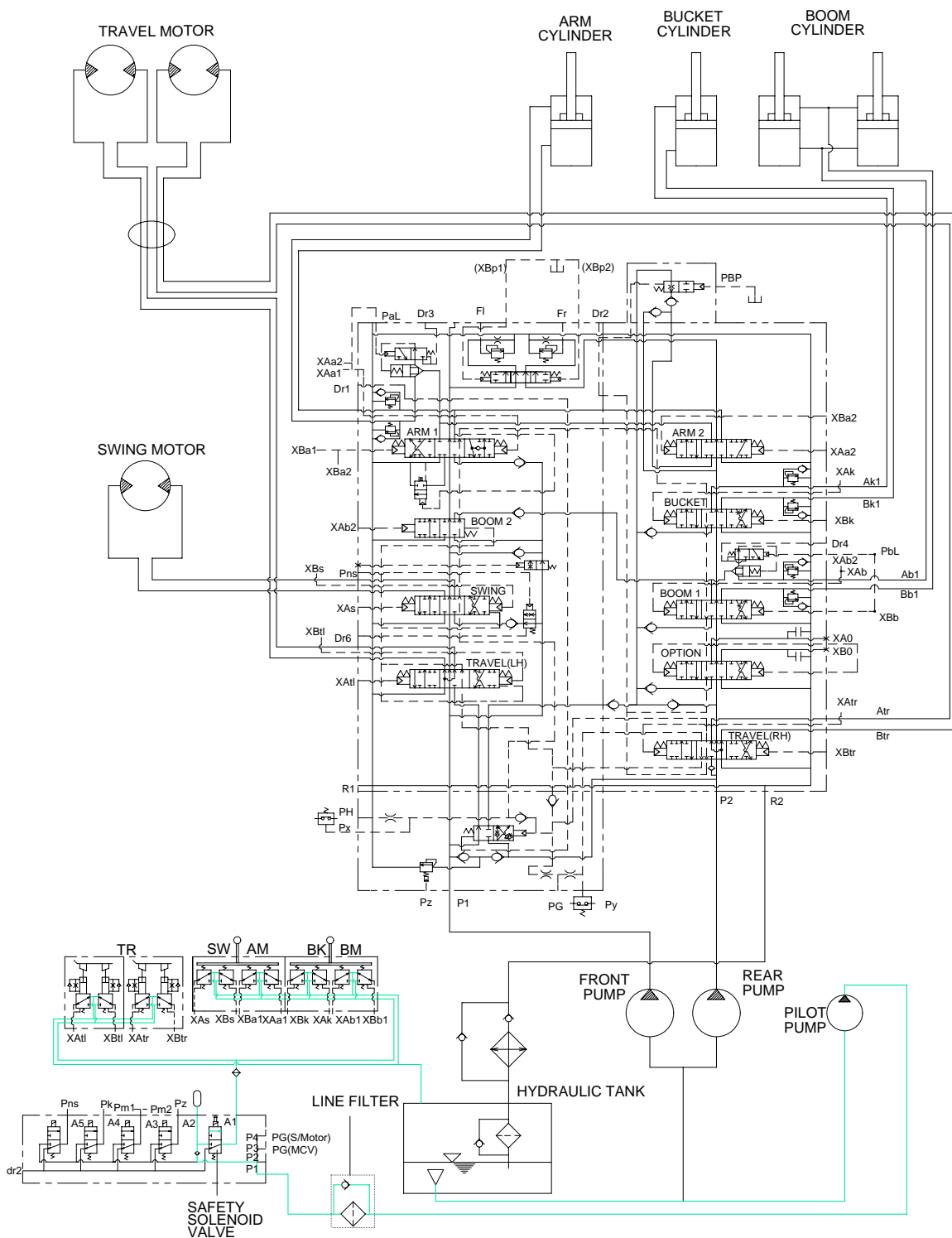

21073HS02

The pilot pump receive oil from the hydraulic tank. The discharged oil from the pilot pump flows to the safety solenoid valve through the line filter. The oil is filtered by the line filter. The pilot relief valve is provided in the pilot pump for limiting the pilot circuit pressure.

The oil filtered by line filter flows remote control valve through safety solenoid valve.

The return oil flow into the hydraulic tank.

2. SAFETY SOLENOID VALVE(SAFETY LEVER)

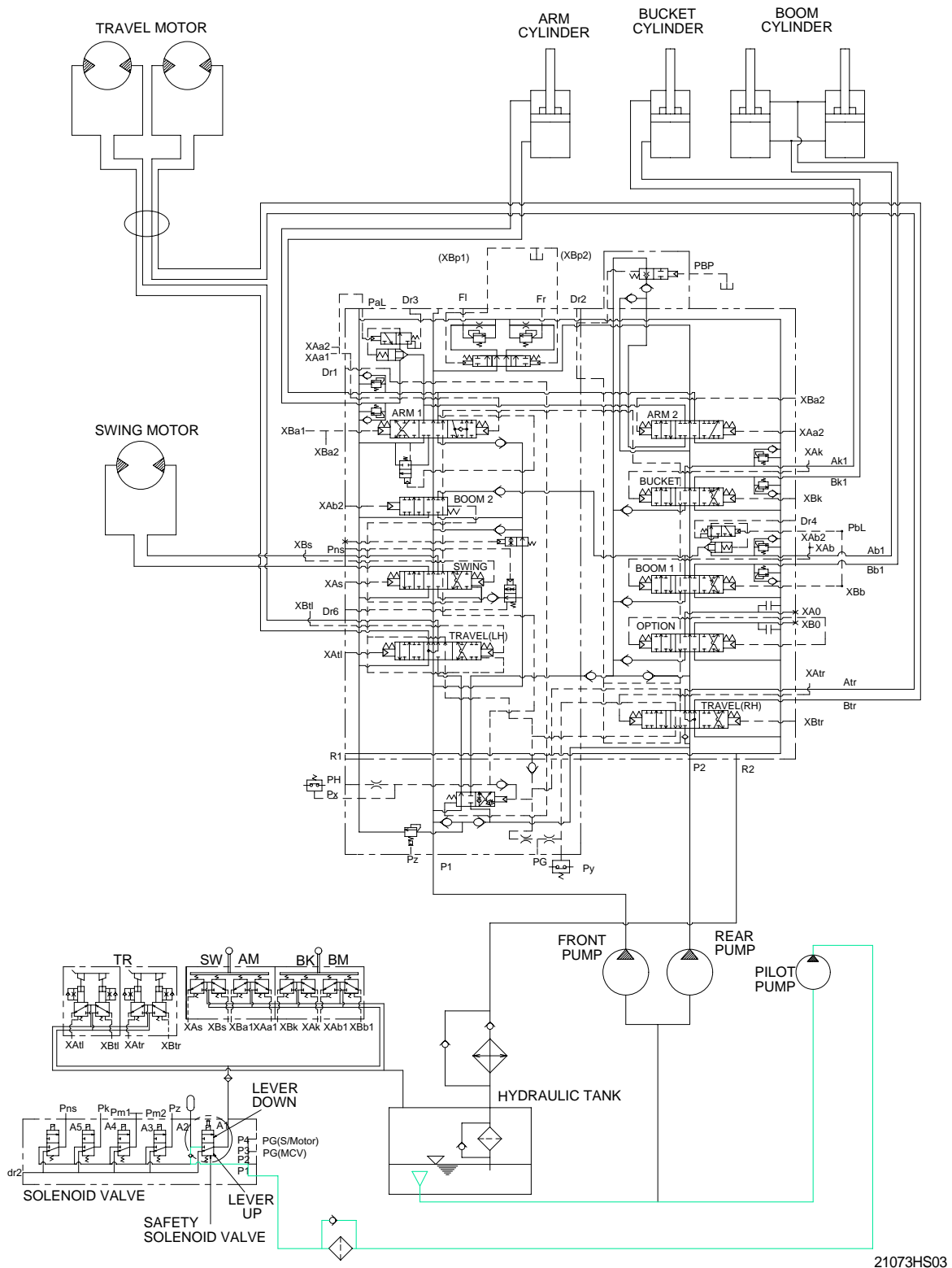

When the lever of the safety solenoid valve is moved downward, oil flows into the remote control valve through solenoid valve and line filter.

When the lever of the safety solenoid valve is moved upward, oil does not flow into the remote control valve, because of the blocked port.

3. BOOM PRIORITY SYSTEM

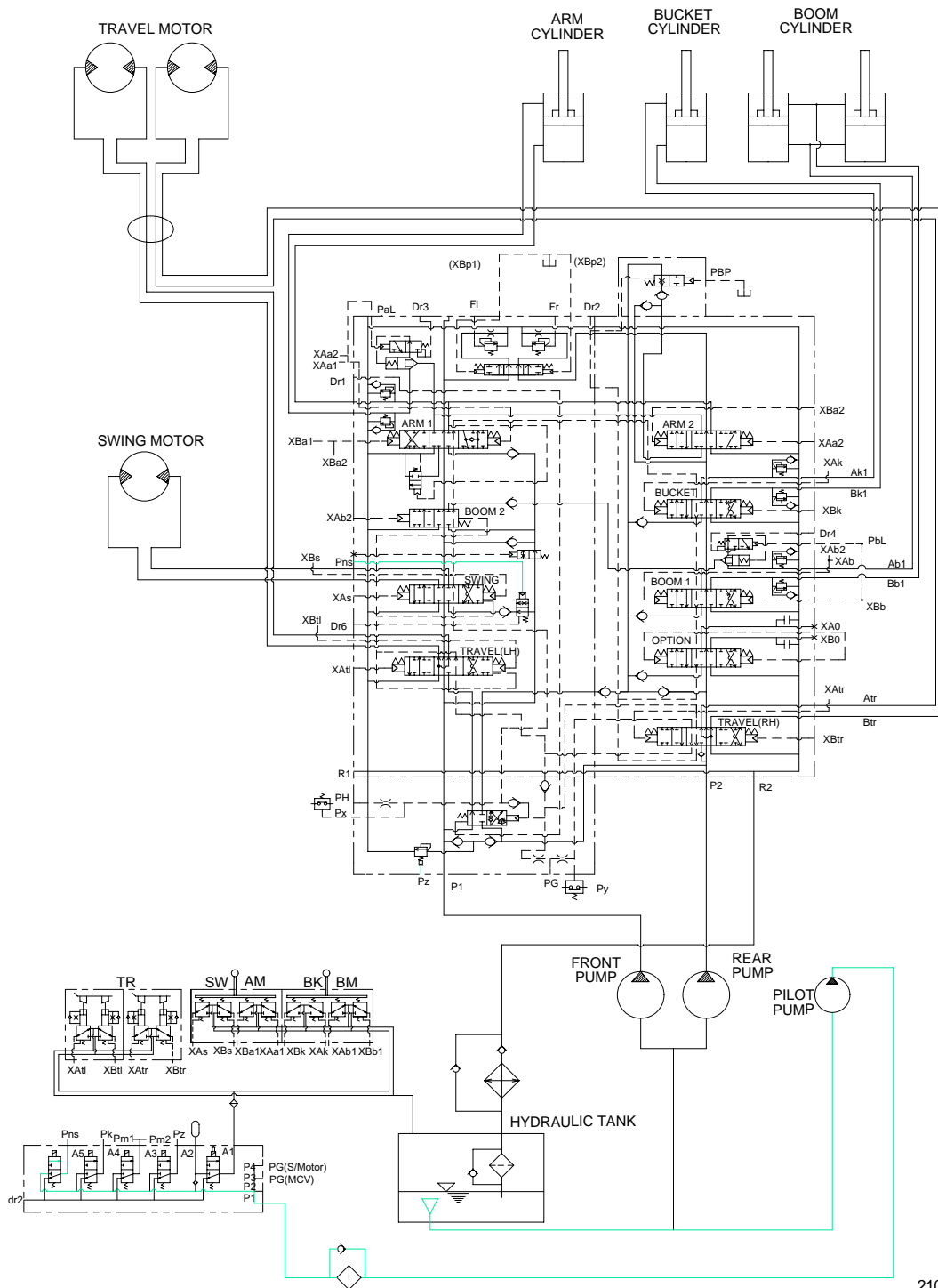

21073HS04

When carrying out the combined operation of swing and boom or arm, the boom or arm operating speed is lowered then normal operation.

To increase working efficiency, swing speed reducing system is used.

When heavy duty working mode in work mode is on, pilot oil from pilot pump flow into Pns port in main control valve through solenoid valve. Pns oil pressure move swing reducing spool to lower position and oil flow rate to the swing motor decreased.

Then, the boom or arm speed is increased.

This is called the boom priority system.

5. MAIN RELIEF PRESSURE CHANGE SYSTEM

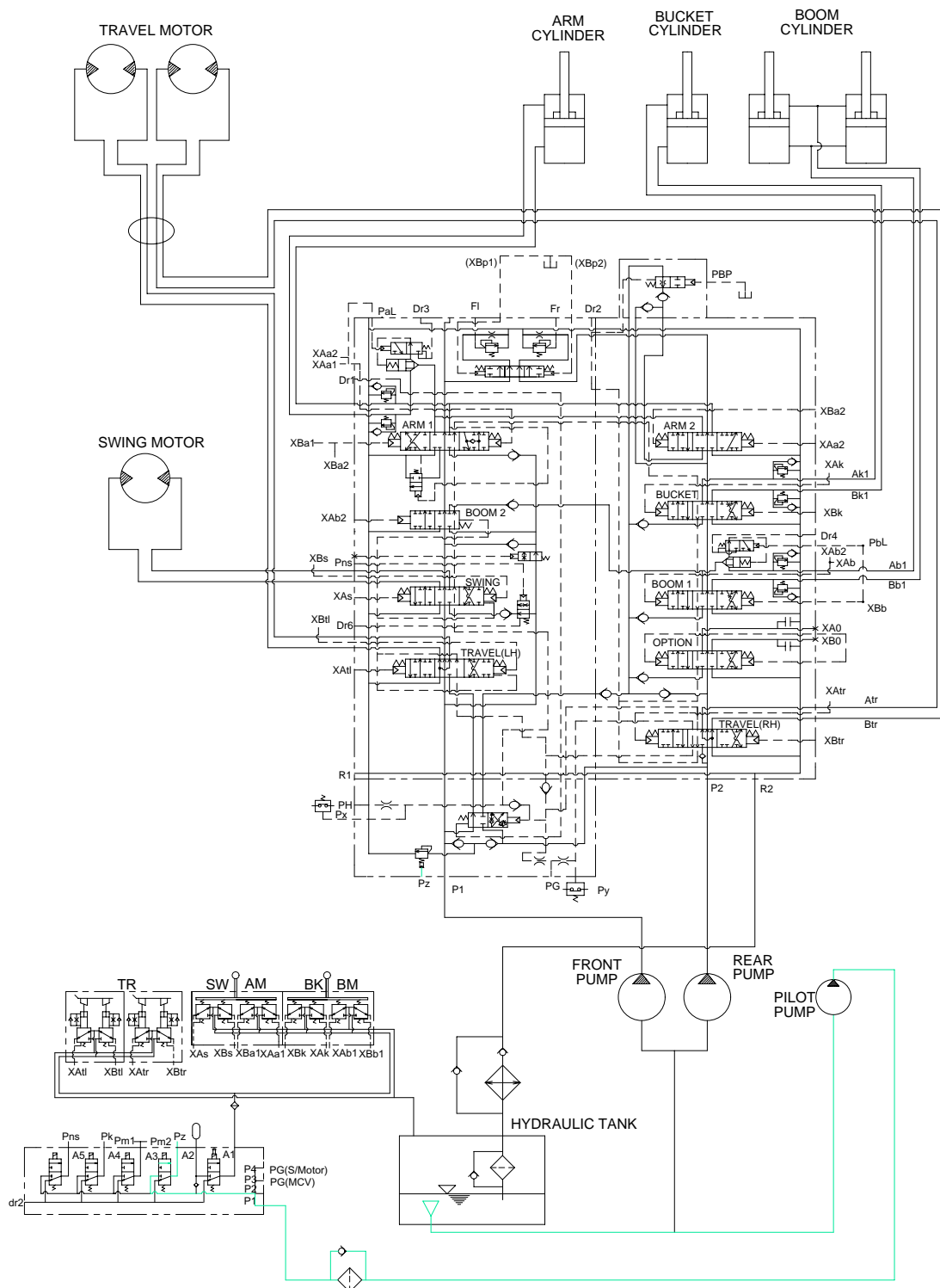

21073HS06

When the power boost switch on the left control lever is pushed ON, the power boost solenoid valve is actuated, the discharged oil from the pilot pump flows into Pz port of the main relief valve of main control valve; then the setting pressure of the main relief valve is raised from 330kgf/cm² to 360kgf/cm² for increasing the digging power. And even when pressed continuously, it is canceled after 8 seconds.

7. SWING PARKING BRAKE RELEASE

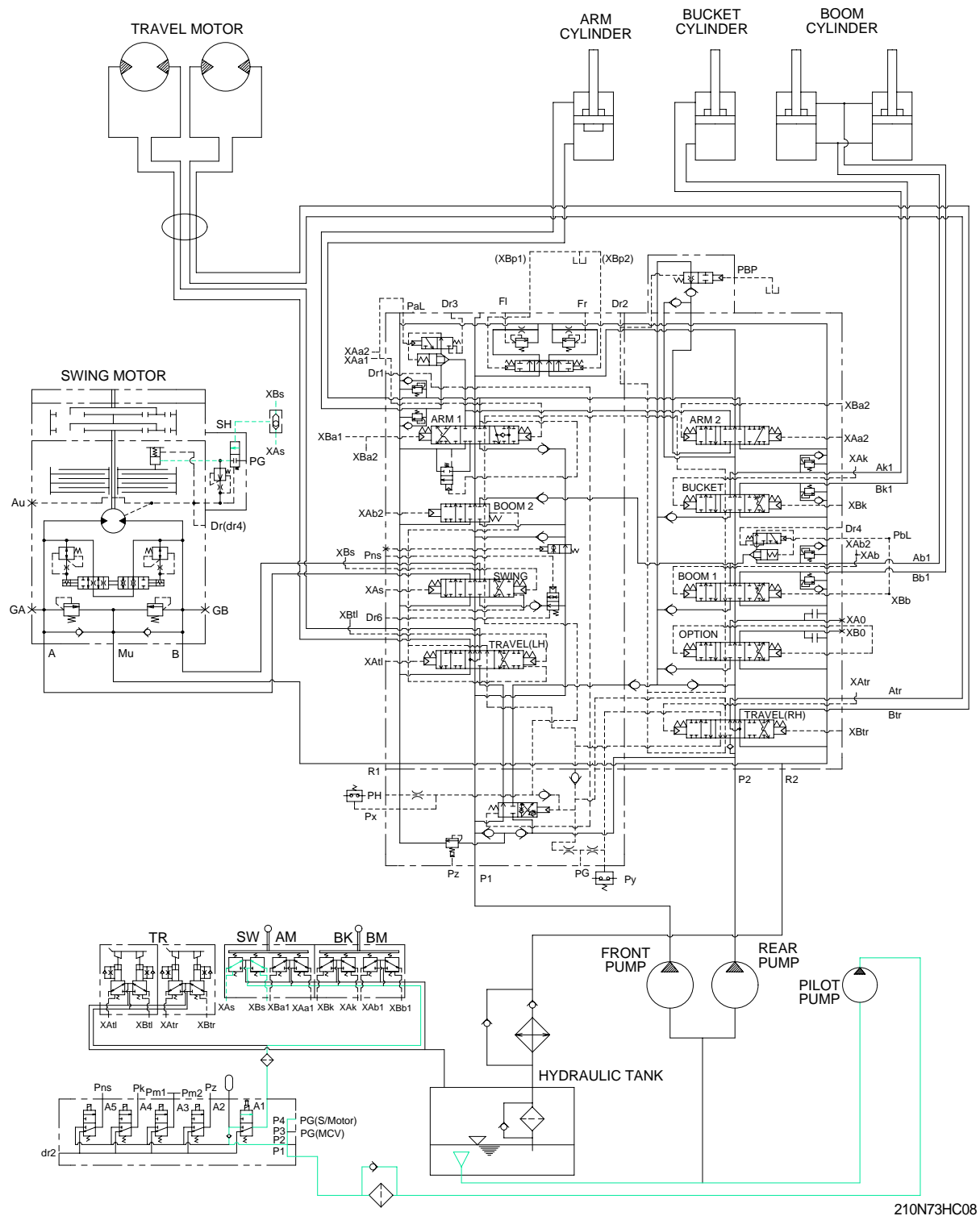

When the swing control lever is tilted, the pilot oil flow into SH port of shuttle valve, this pressure move spool so, discharged oil from pilot valve flow into PG port.

This pressure is applied to swing motor disc, thus the brake is released.

When the swing control lever is set in the neutral position, oil in the swing motor disc cylinder is drained, thus the brake is applied.