

GROUP 4 MECHATRONICS SYSTEM

1. ALL ACTUATORS SPEED ARE SLOW

- ※ Boom, Arm, Bucket, Swing and travel speed are slow, but engine speed is good.
- ※ Spec : P-mode 1950 ± 50 rpm S-mode 1750 ± 50 rpm E-mode 1600 ± 50 rpm
- ※ Before carrying out below procedure, check all the related connectors are properly inserted and fault code on the cluster.

1) INSPECTION PROCEDURE

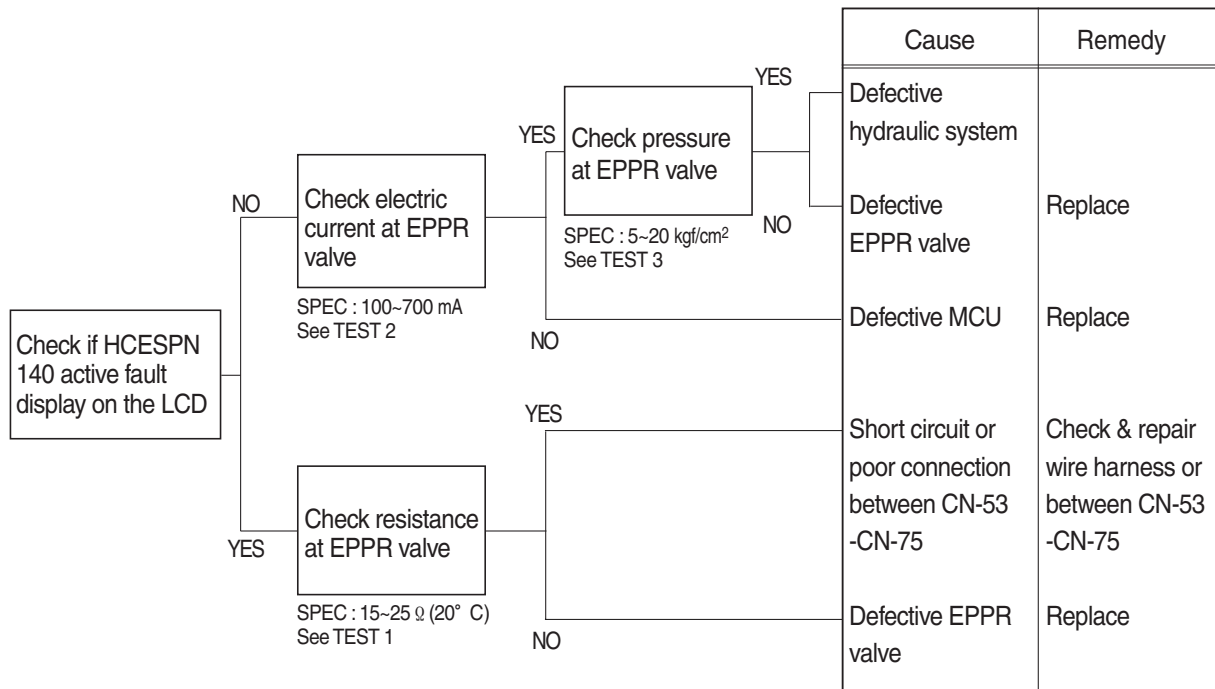

Wiring diagram

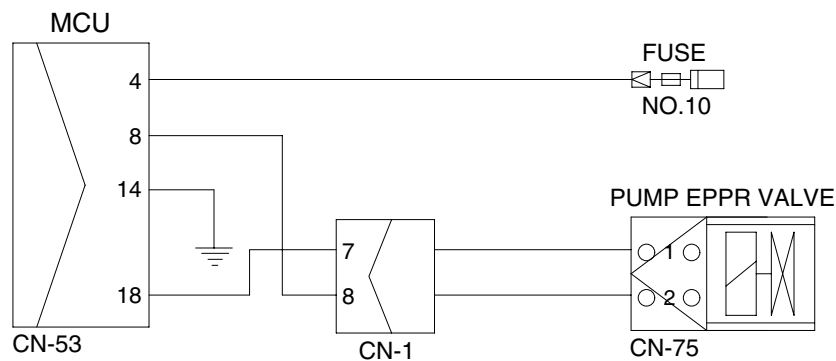

2) TEST PROCEDURE

(1) **Test 1** : Check resistance at connector CN-75.

- ① Starting key OFF.
- ② Disconnect connector CN-75 from EPPR valve at main hydraulic pump.
- ③ Check resistance between 2 lines as figure.

SPEC : 15~25 Ω (20°C)

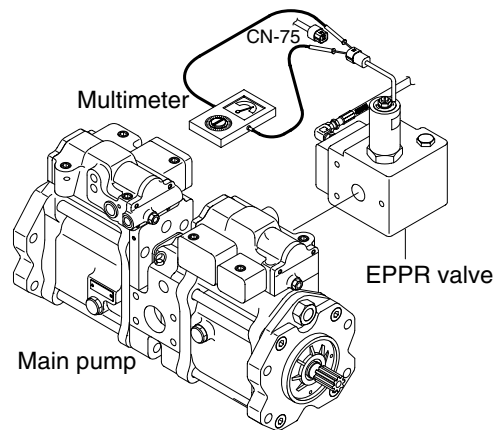

2107A5MS15

(2) **Test 2** : Check electric current at EPPR valve.

- ① Disconnect connector CN-75 from EPPR valve.
- ② Insert the adapter to CN-75 and install multimeter as figure.
- ③ Start engine.
- ④ Set S-mode and cancel auto decel mode.
- ⑤ Position the accel dial at 10.
- ⑥ If tachometer show approx 1750 ± 50 rpm disconnect one wire harness from EPPR valve.
- ⑦ Check electric current at bucket circuit relief position.

Spec : 100~700 mA

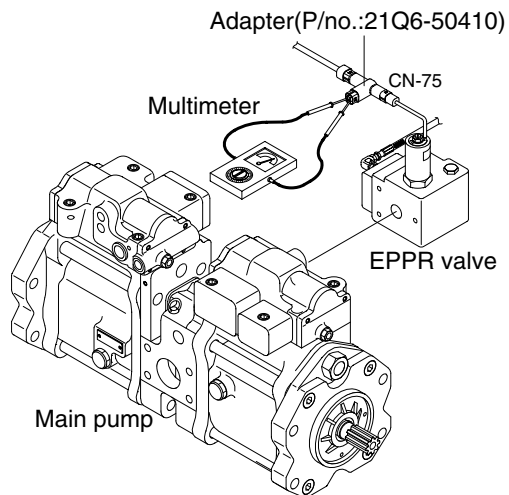

21095MS21

(3) **Test 3** : Check pressure at EPPR valve.

- ① Remove plug and connect pressure gauge as figure.
 - Gauge capacity : 0 to 50 kgf/cm² (0 to 710 psi)
- ② Start engine.
- ③ Set S-mode and cancel auto decel mode.
- ④ Position the accel dial at 10.
- ⑤ If tachometer show approx 1750 ± 50 rpm check pressure at relief position of bucket circuit by operating bucket control lever.
- ⑥ If pressure is not correct, adjust it.
- ⑦ After adjust, test the machine.

Spec : 2~25 kgf/cm² (30~350 psi)

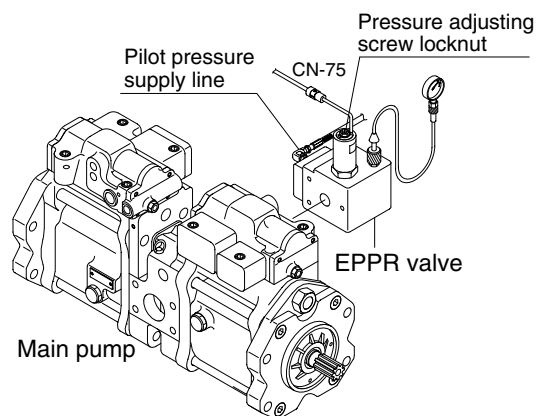

2107A5MS13

2. ENGINE STALL

※ Before carrying out below procedure, check all the related connectors are properly inserted.

1) INSPECTION PROCEDURE

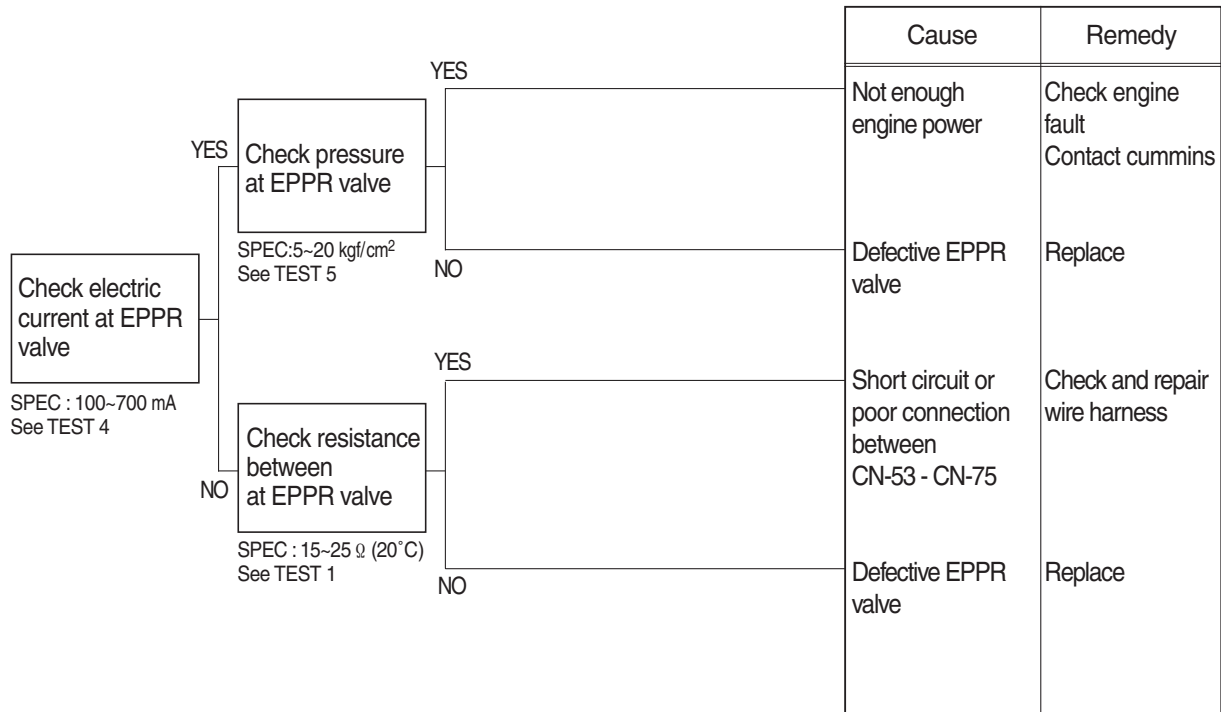

Wiring diagram

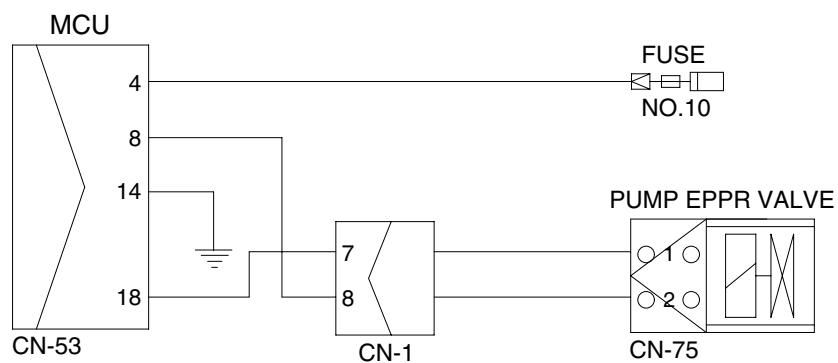

21096MS01

2) TEST PROCEDURE

(1) Test 4 : Check electric current at EPPR valve at S-mode

- ① Install multimeter as figure.
- ② Start engine.
- ③ Set the accel dial at "10" (max)
- ④ Set S-mode with 1750 ± 50 rpm.
- ⑤ Check electric current.

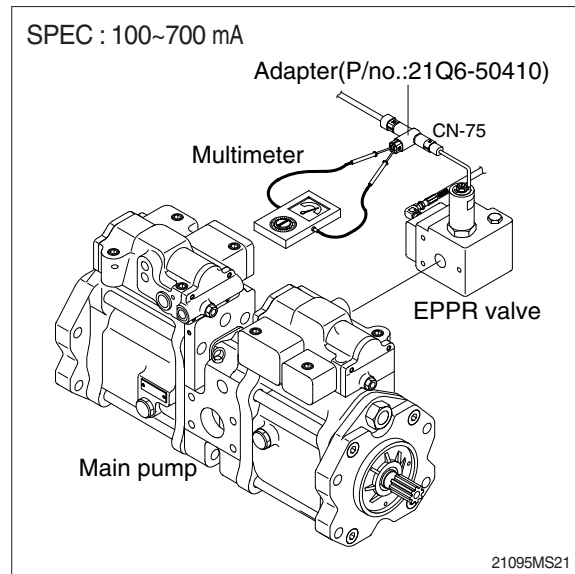

(2) Test 5 : Check pressure at EPPR valve at S-mode

- ① Connect pressure gauge at EPPR valve.
- ② Start engine.
- ③ Set the accel dial at "10" (max)
- ④ Set S-mode with 1750 ± 50 rpm.
- ⑤ Operate bucket lever completely push or pull.
- ⑥ Hold arm lever at the end of stroke.
- ⑦ Check pressure at relief position.

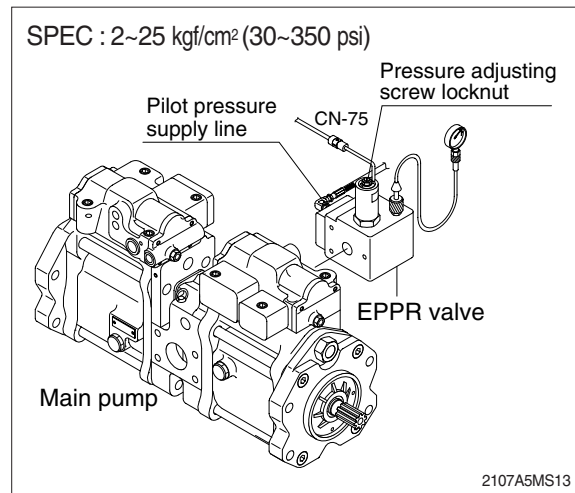

3. MALFUNCTION OF CLUSTER OR MODE SELECTION SYSTEM

· Fault code : HCESPN 840, FMI 2

※ Before carrying out below procedure, check all the related connectors are properly inserted.

1) INSPECTION PROCEDURE

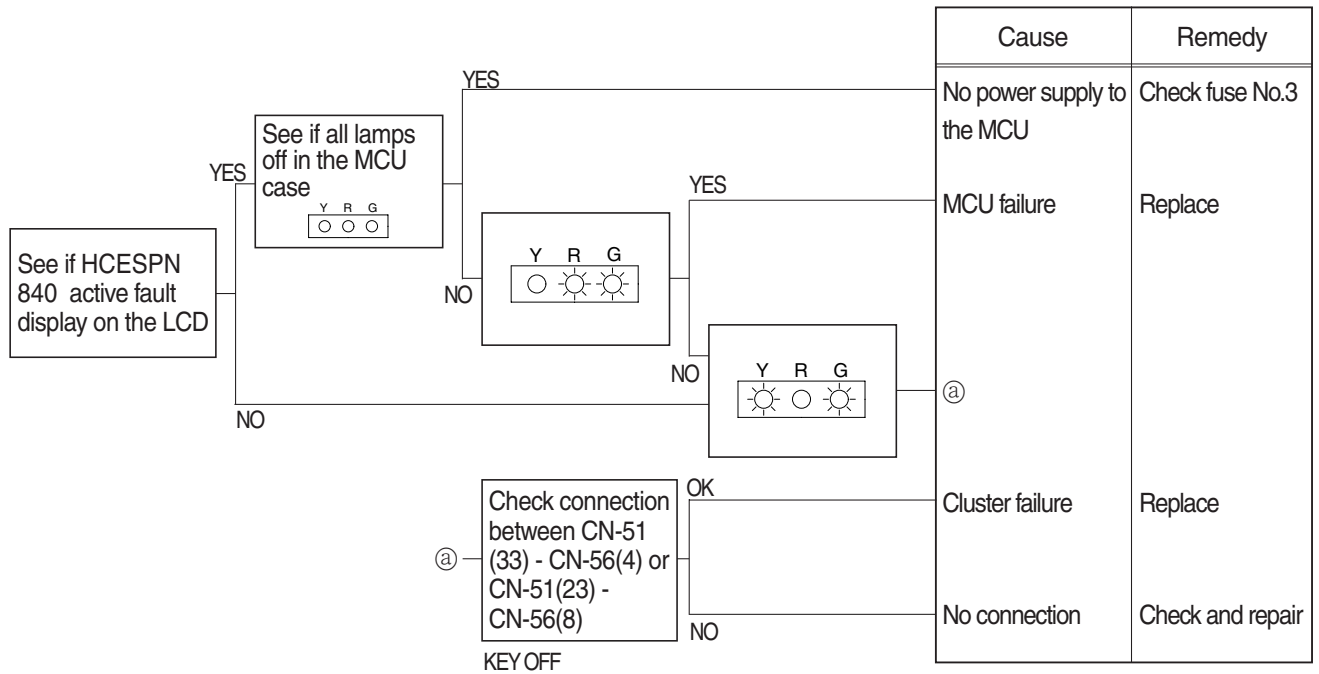

Wiring diagram

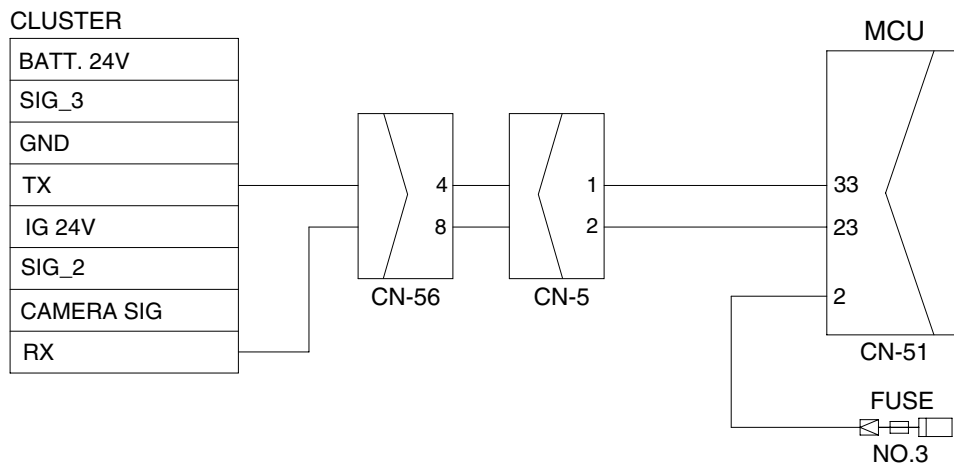

21096MS03

4. MALFUNCTION OF ACCEL DIAL

· Fault code : HCESPN 714, FMI 3 or 4

※ Before carrying out below procedure, check all the related connectors are properly inserted.

1) INSPECTION PROCEDURE

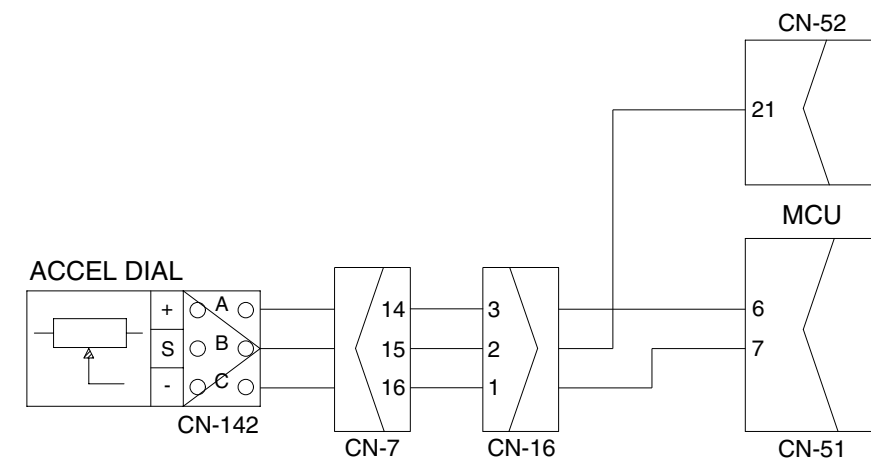
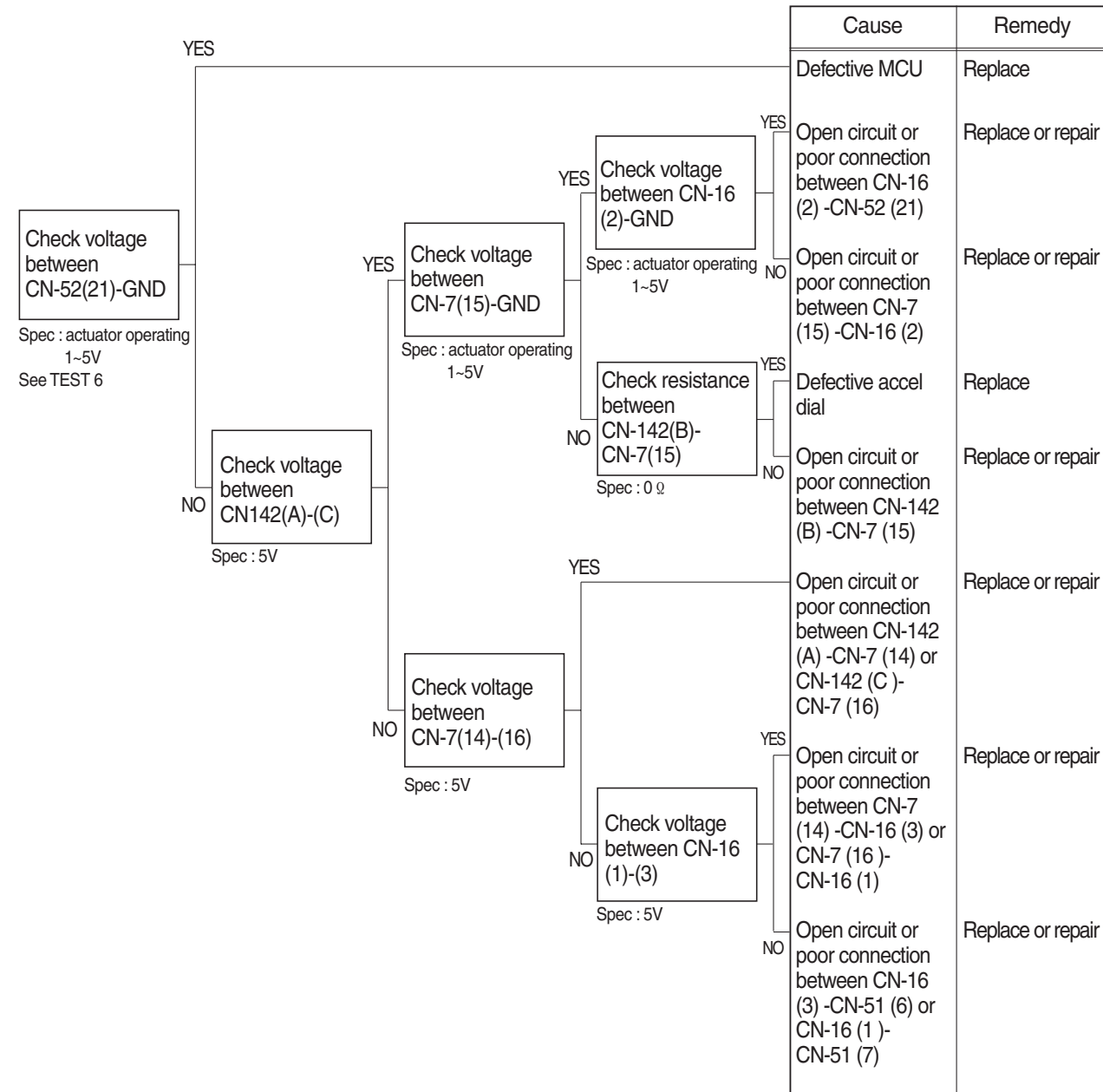

2) TEST PROCEDURE

(1) **Test 6** : Check voltage at CN-52(21) and ground.

- ① Prepare 1 piece of thin sharp pin, steel or copper.
- ② Insert prepared pin to rear side of connectors : One pin to (21) of CN-52.
- ③ Starting key ON.
- ④ Check voltage as figure.

SPEC : Actuator operating : 1~5 V

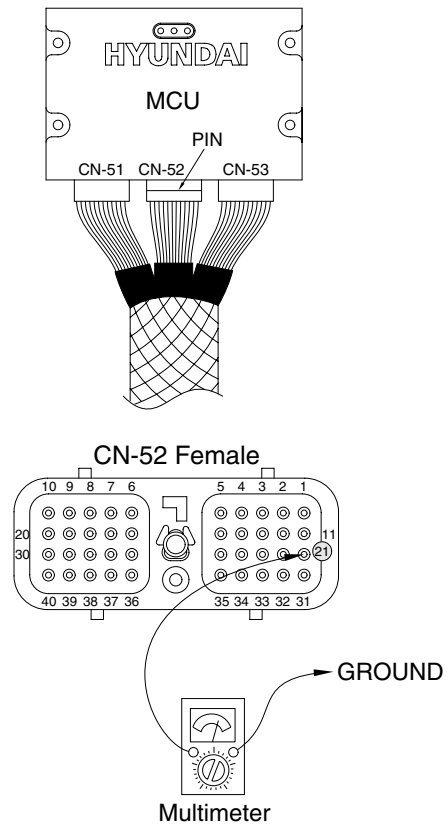

21096MS04A

5. AUTO DECEL SYSTEM DOES NOT WORK

- Fault code : HCESPN 105, FMI 0~4 (work pressure sensor)
HCESPN 108, FMI 0~4 (travel oil pressure sensor)

※ Before carrying out below procedure, check all the related connectors are properly inserted.

1) INSPECTION PROCEDURE

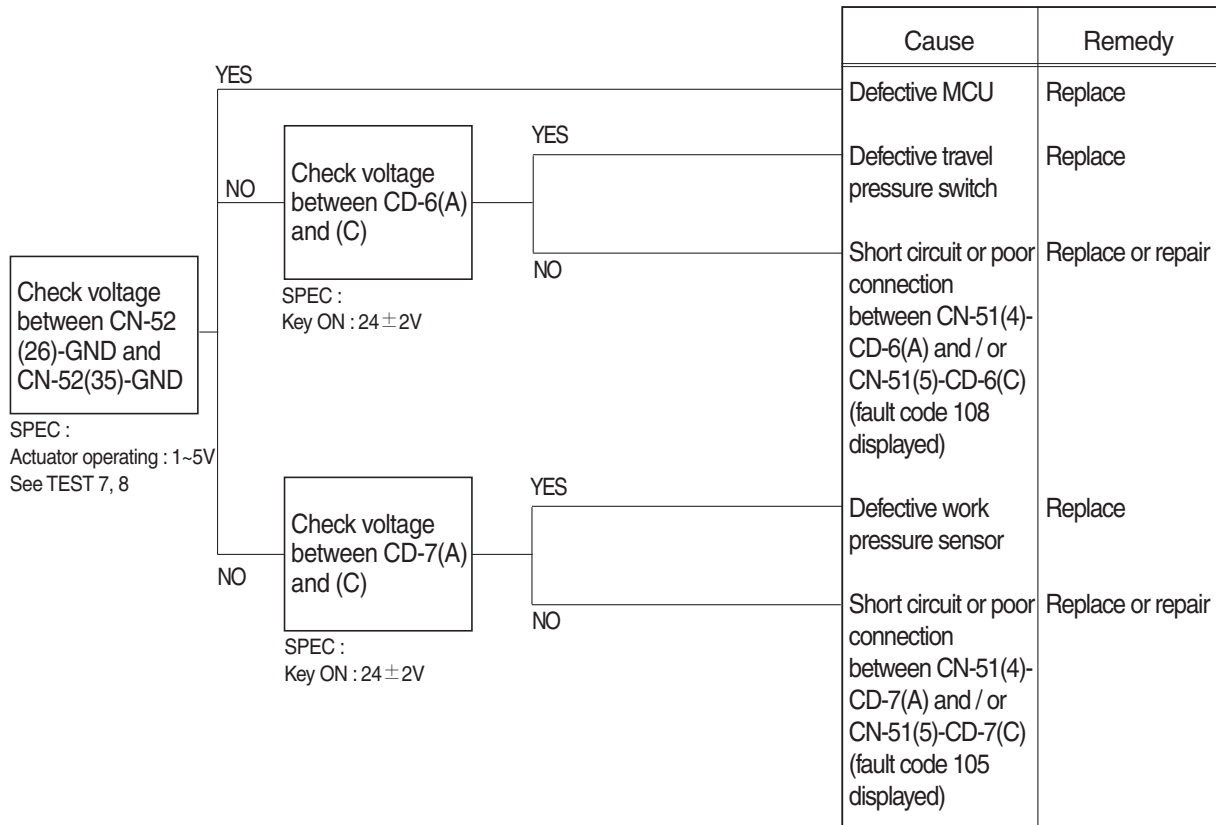

Wiring diagram

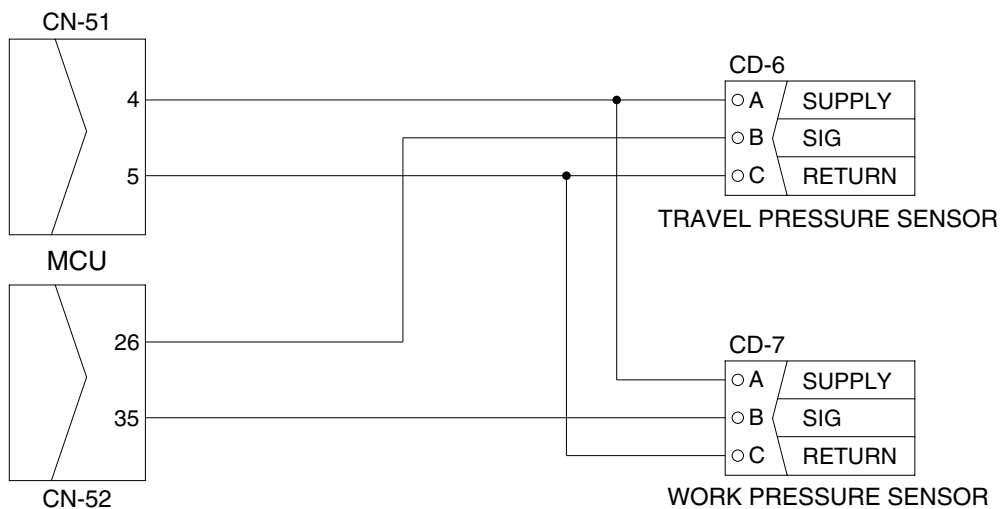

21096MS05

2) TEST PROCEDURE

(1) **Test 7** : Check voltage at CN-52(26) and ground.

- ① Prepare 1 piece of thin sharp pin, steel or copper.
- ② Insert prepared pin to rear side of connectors : One pin to (26) of CN-52.
- ③ Starting key ON.
- ④ Check voltage as figure.

(2) **Test 8** : Check voltage at CN-52(35) and ground.

- ① Prepare 1 piece of thin sharp pin, steel or copper
- ② Insert prepared pin to rear side of connectors : One pin to (35) of CN-52.
- ③ Starting key ON.
- ④ Check voltage as figure.

SPEC : Actuator operating : 1~5 V

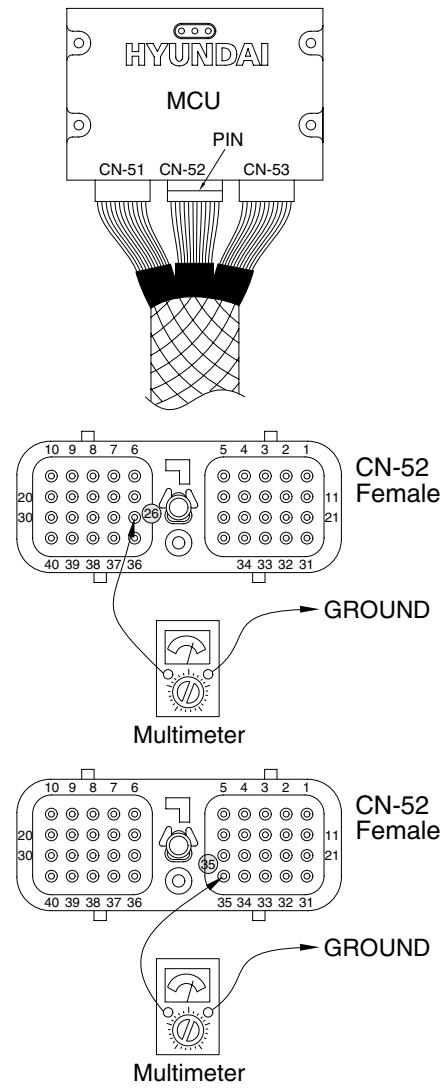

21096MS05A

6. MALFUNCTION OF PUMP 1 PRESSURE SENSOR

· Fault code : HCESPN 120, FMI 0~4

※ Before carrying out below procedure, check all the related connectors are properly inserted.

1) INSPECTION PROCEDURE

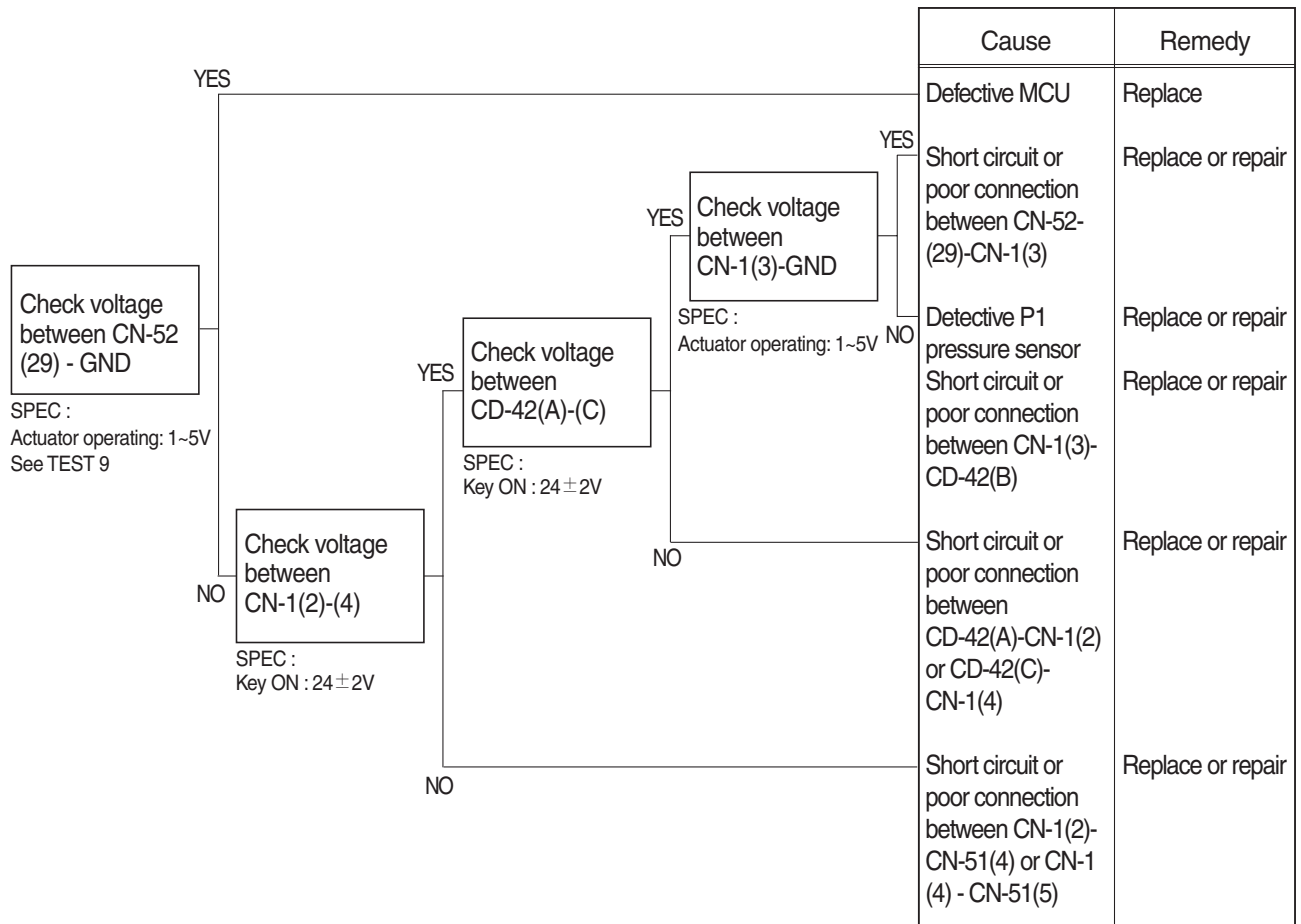

Wiring diagram

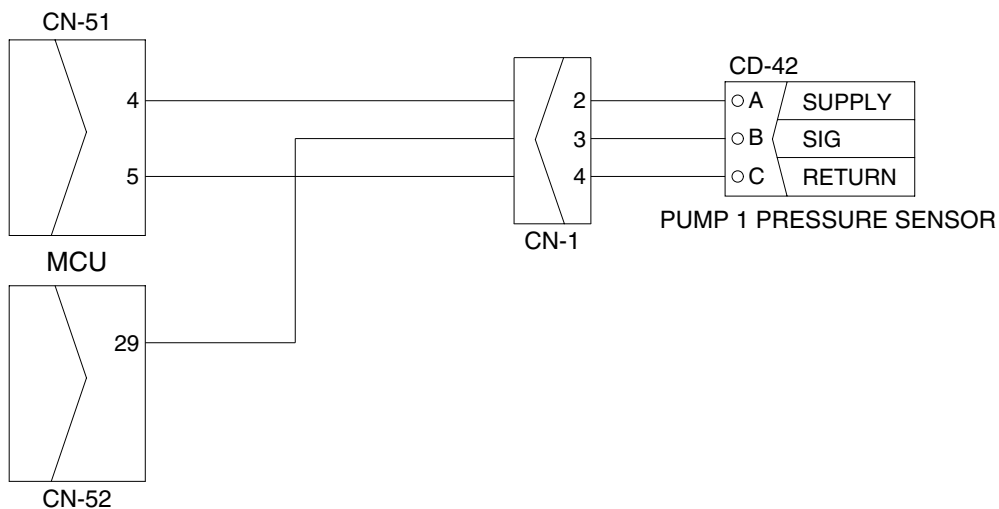

21096MS06

2) TEST PROCEDURE

(1) **Test 9** : Check voltage at CN-52(29) and ground.

- ① Prepare 1 piece of thin sharp pin, steel or copper.
- ② Insert prepared pin to rear side of connectors : One pin to (29) of CN-52.
- ③ Starting key ON.
- ④ Check voltage as figure.

SPEC : Actuator operating : 1~5 V

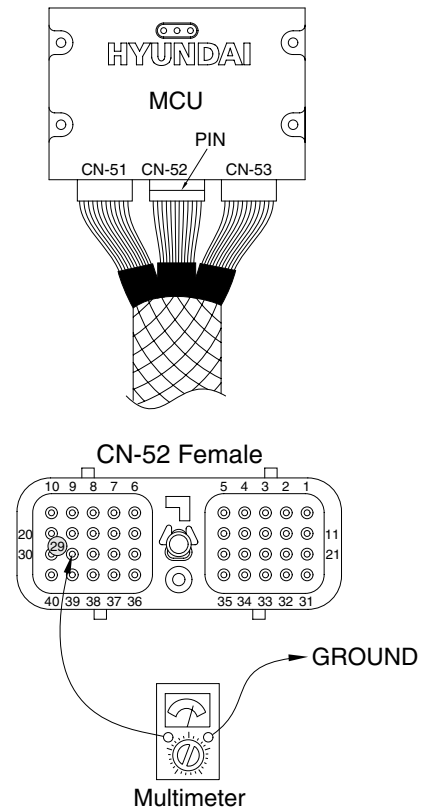

21096MS06A

7. MALFUNCTION OF PUMP 2 PRESSURE SENSOR

· Fault code : HCESPN 121, FMI 0~4

※ Before carrying out below procedure, check all the related connectors are properly inserted.

1) INSPECTION PROCEDURE

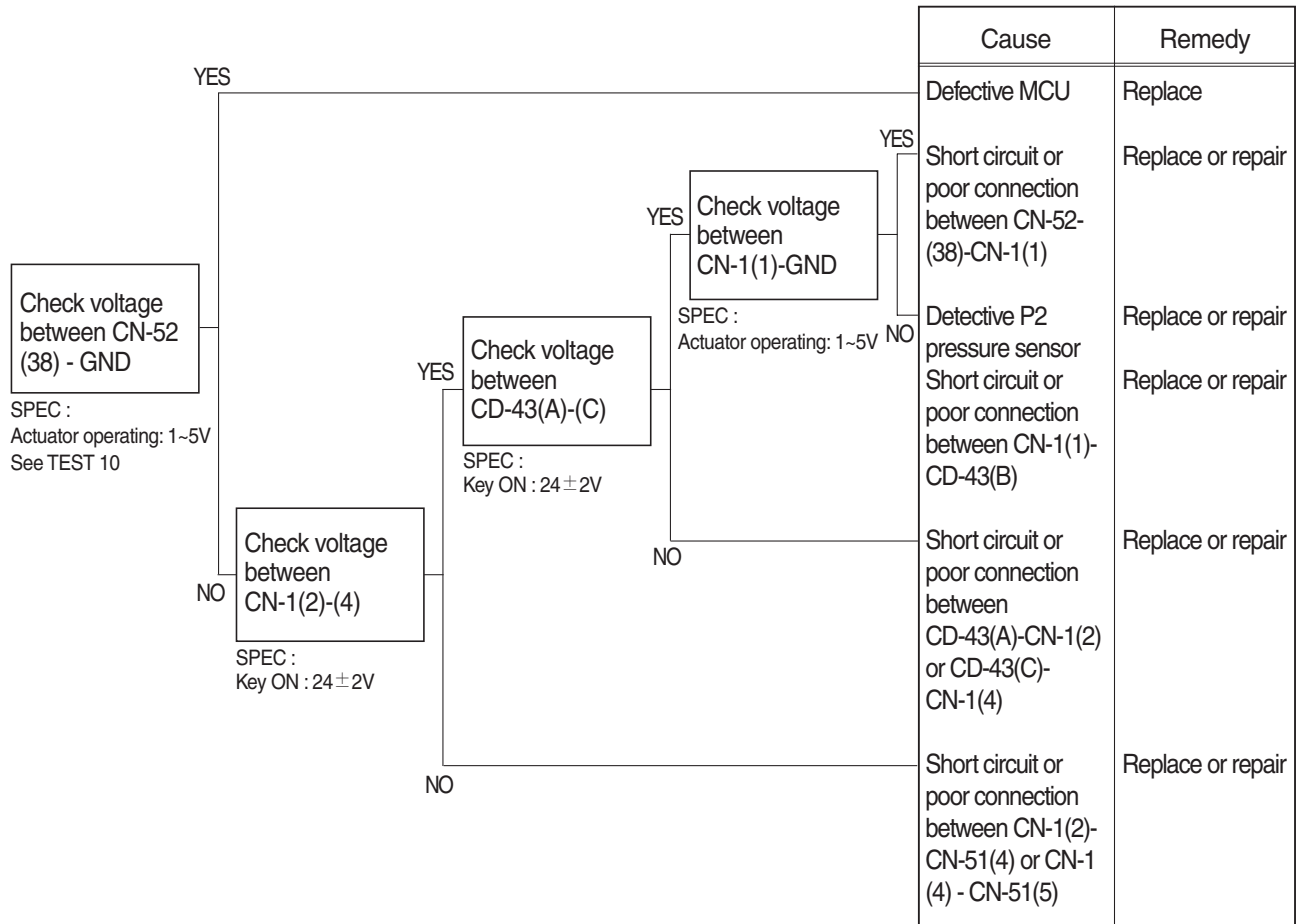

Wiring diagram

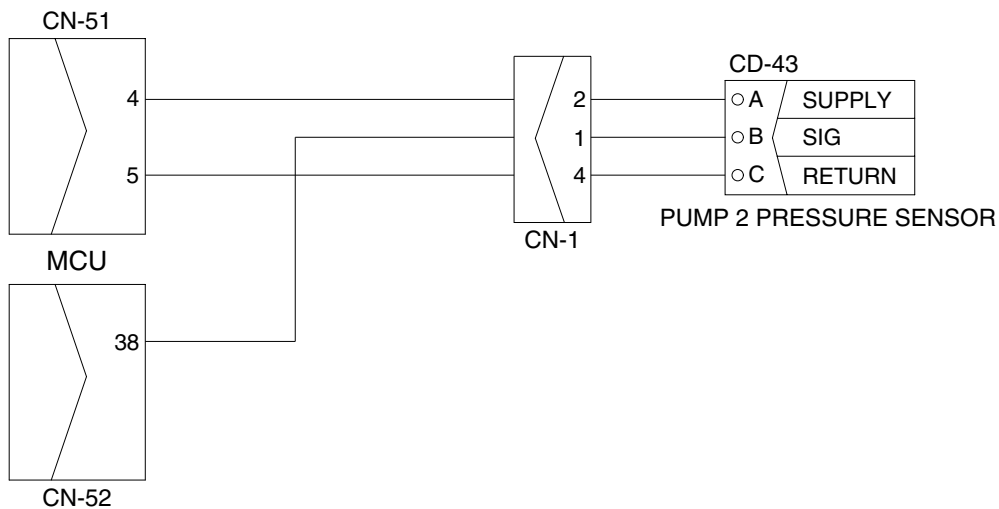

21096MS07

2) TEST PROCEDURE

(1) Test 10 : Check voltage at CN-52(38) and ground.

- ① Prepare 1 piece of thin sharp pin, steel or copper.
- ② Insert prepared pin to rear side of connectors : One pin to (38) of CN-52.
- ③ Starting key ON.
- ④ Check voltage as figure.

SPEC : Actuator operating : 1~5 V

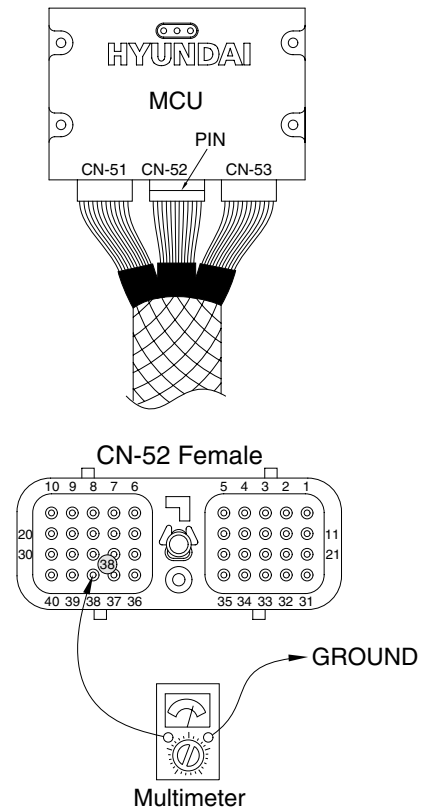

21096MS07A

8. MALFUNCTION OF PUMP 3 PRESSURE SENSOR

· Fault code : HCESPN 125, FMI 0~4

※ Before carrying out below procedure, check all the related connectors are properly inserted.

1) INSPECTION PROCEDURE

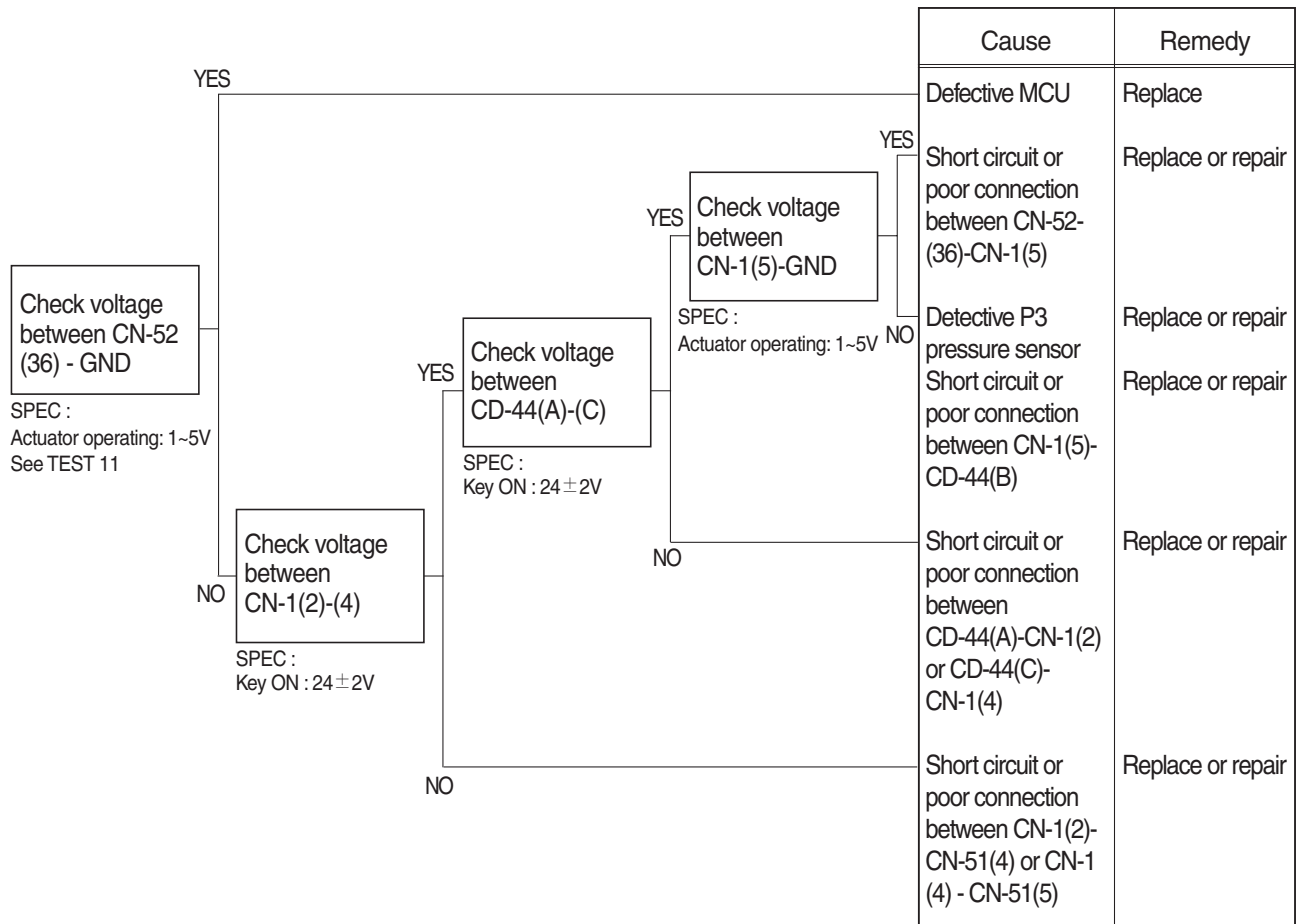

Wiring diagram

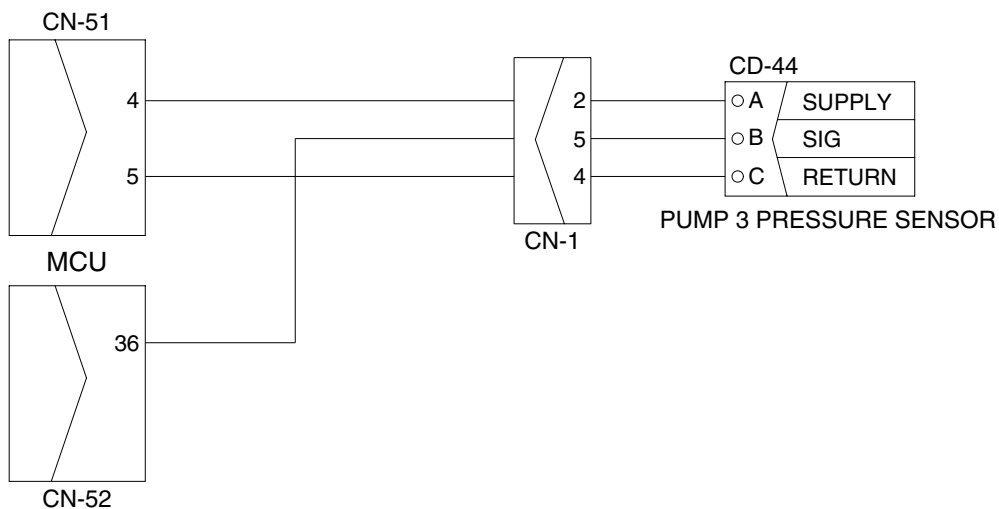

21096MS08

2) TEST PROCEDURE

(1) **Test 11** : Check voltage at CN-52(36) and ground.

- ① Prepare 1 piece of thin sharp pin, steel or copper.
- ② Insert prepared pin to rear side of connectors : One pin to (36) of CN-52.
- ③ Starting key ON.
- ④ Check voltage as figure.

SPEC : Actuator operating : 1~5 V

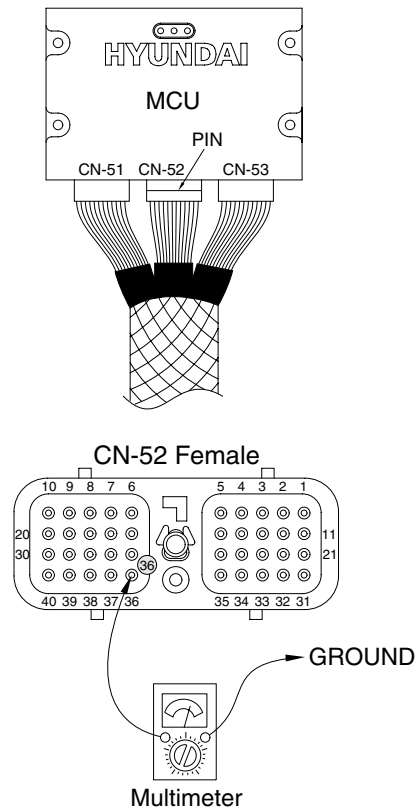

21096MS08A

9. MALFUNCTION OF NEGATIVE 1 PRESSURE SENSOR

· Fault code : HCESPN 123, FMI 0~4

※ Before carrying out below procedure, check all the related connectors are properly inserted.

1) INSPECTION PROCEDURE

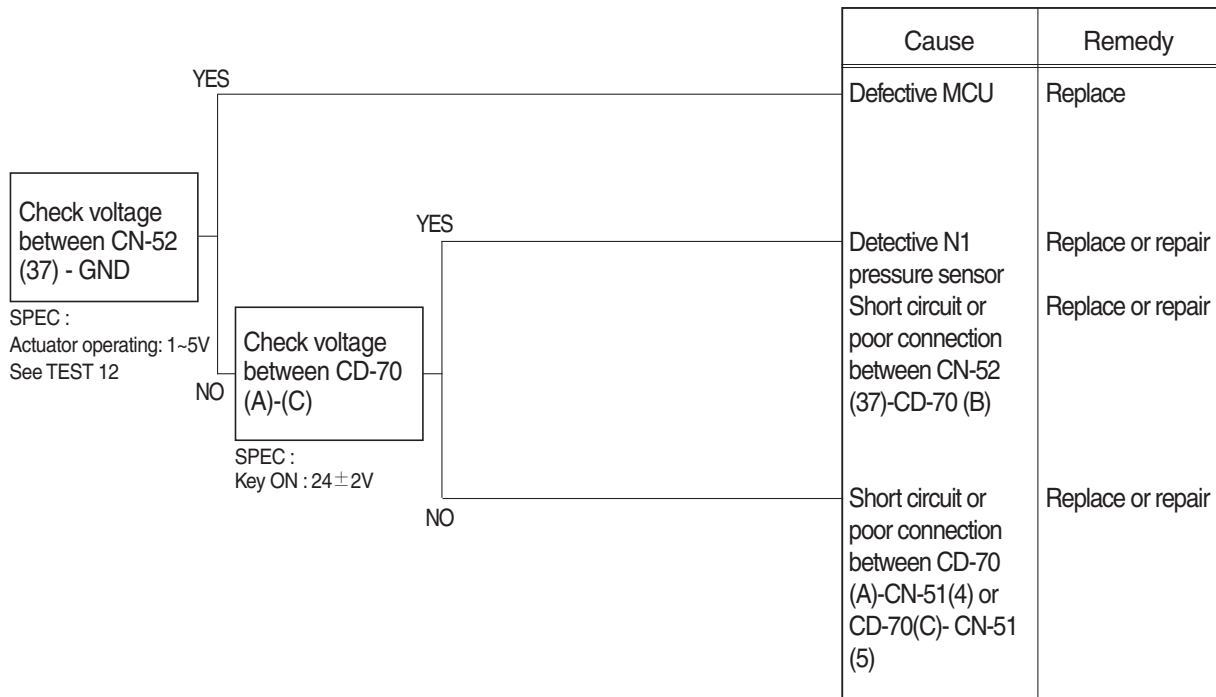

Wiring diagram

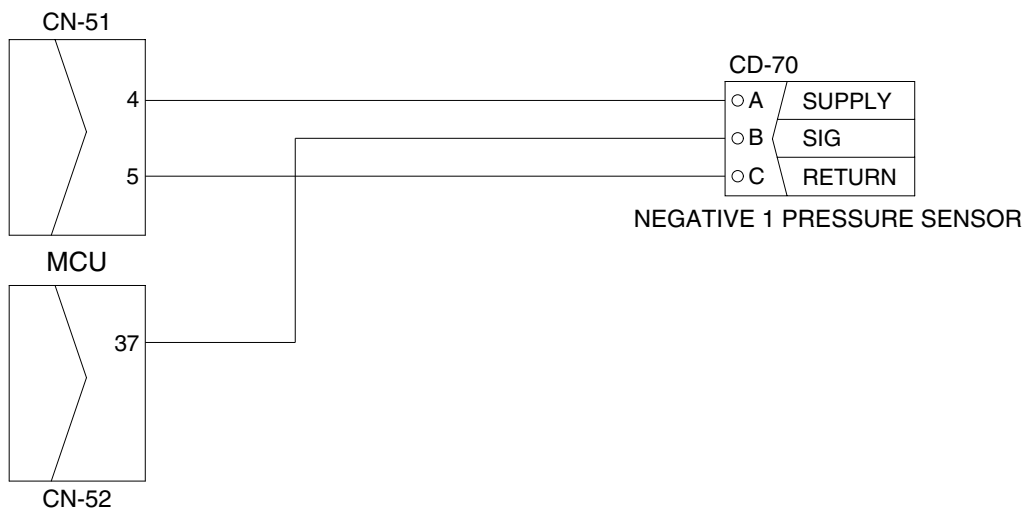

21096MS09

2) TEST PROCEDURE

(1) **Test 12** : Check voltage at CN-52(37) and ground.

- ① Prepare 1 piece of thin sharp pin, steel or copper.
- ② Insert prepared pin to rear side of connectors : One pin to (37) of CN-52.
- ③ Starting key ON.
- ④ Check voltage as figure.

SPEC : Actuator operating : 1~5 V

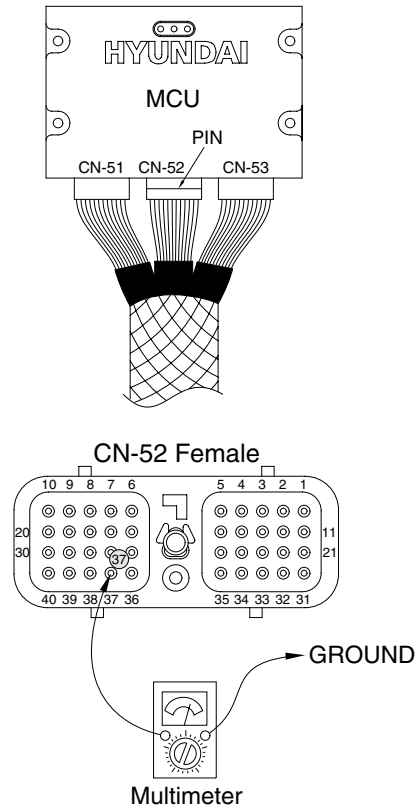

21096MS09A

10. MALFUNCTION OF NEGATIVE 2 PRESSURE SENSOR

· Fault code : HCESPN 124, FMI 0~4

※ Before carrying out below procedure, check all the related connectors are properly inserted.

1) INSPECTION PROCEDURE

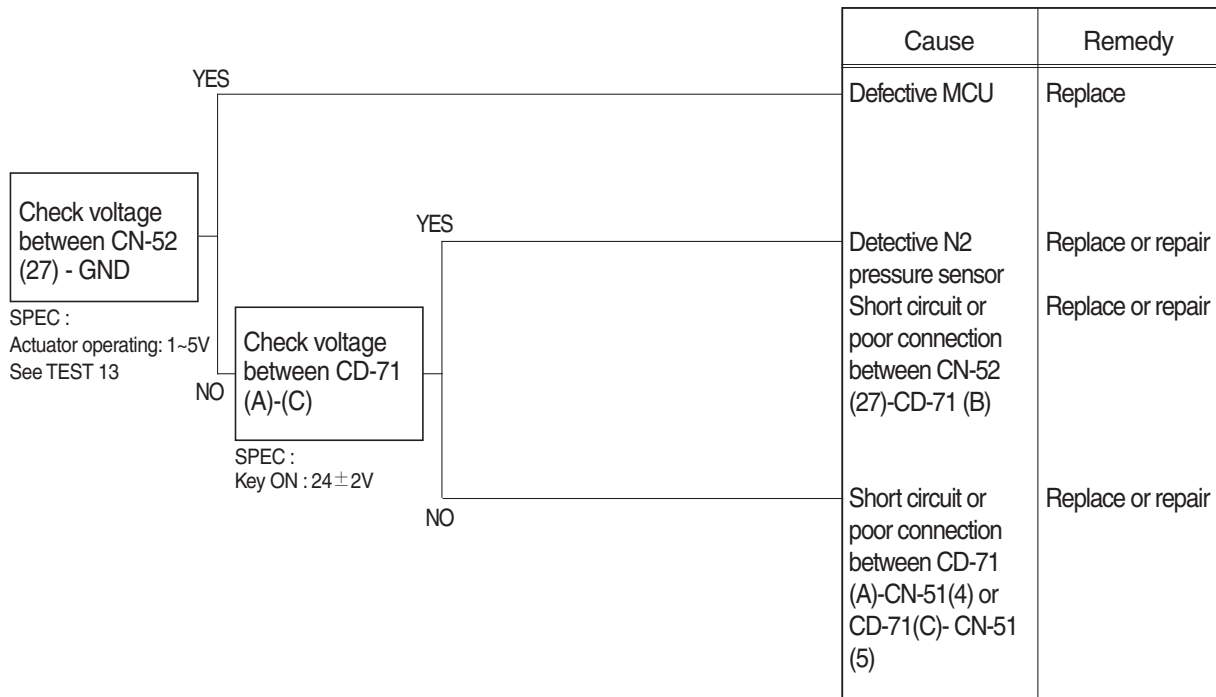

Wiring diagram

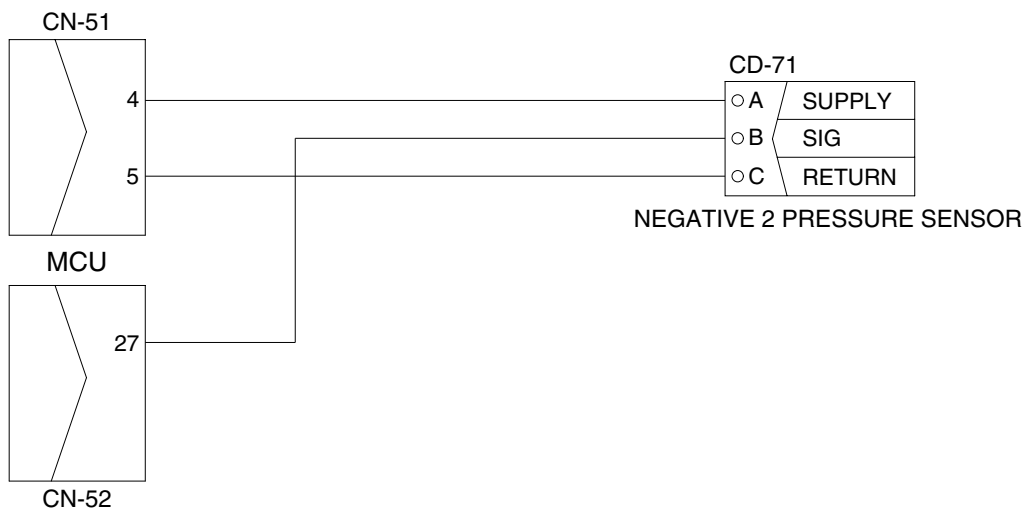

21096MS10

2) TEST PROCEDURE

(1) **Test 13** : Check voltage at CN-52(27) and ground.

- ① Prepare 1 piece of thin sharp pin, steel or copper.
- ② Insert prepared pin to rear side of connectors : One pin to (27) of CN-52.
- ③ Starting key ON.
- ④ Check voltage as figure.

SPEC : Actuator operating : 1~5 V

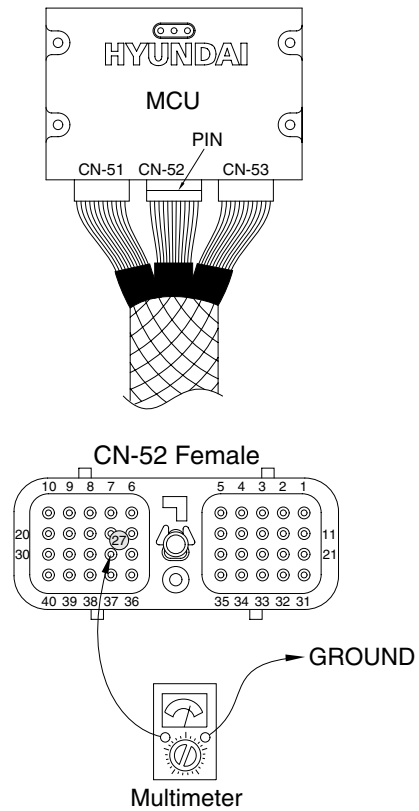

21096MS10A

11. MALFUNCTION OF SWING PRESSURE SENSOR

· Fault code : HCESPN 135, FMI 0~4

※ Before carrying out below procedure, check all the related connectors are properly inserted.

1) INSPECTION PROCEDURE

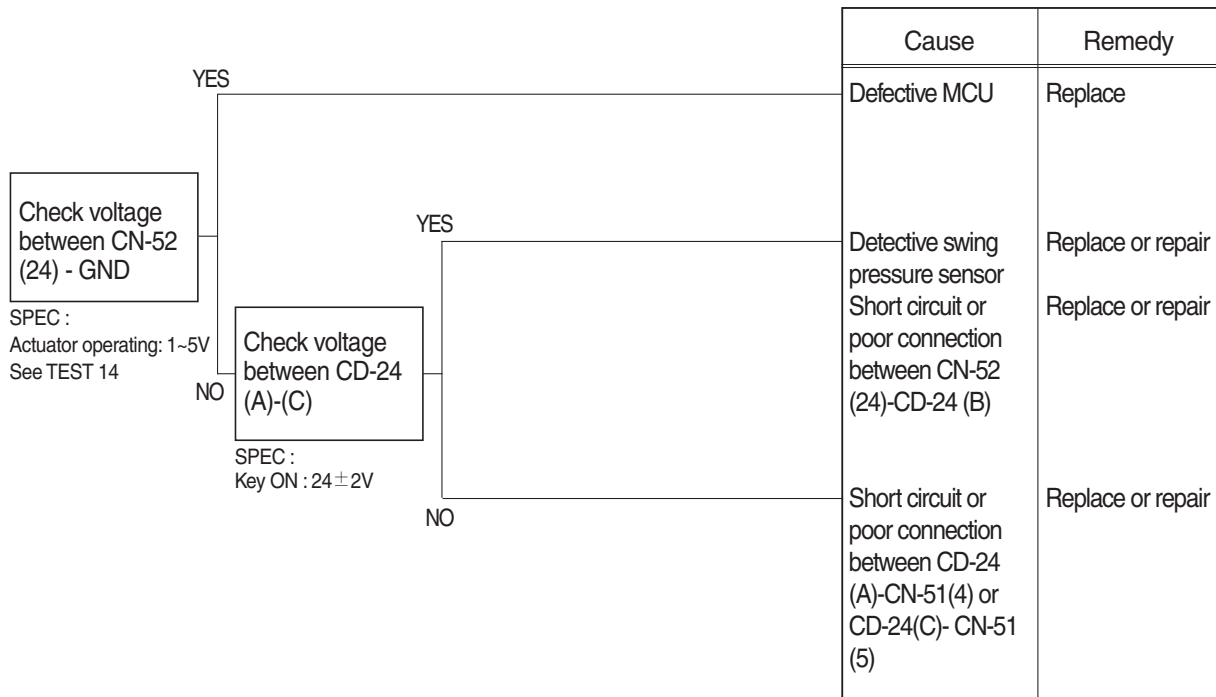

Wiring diagram

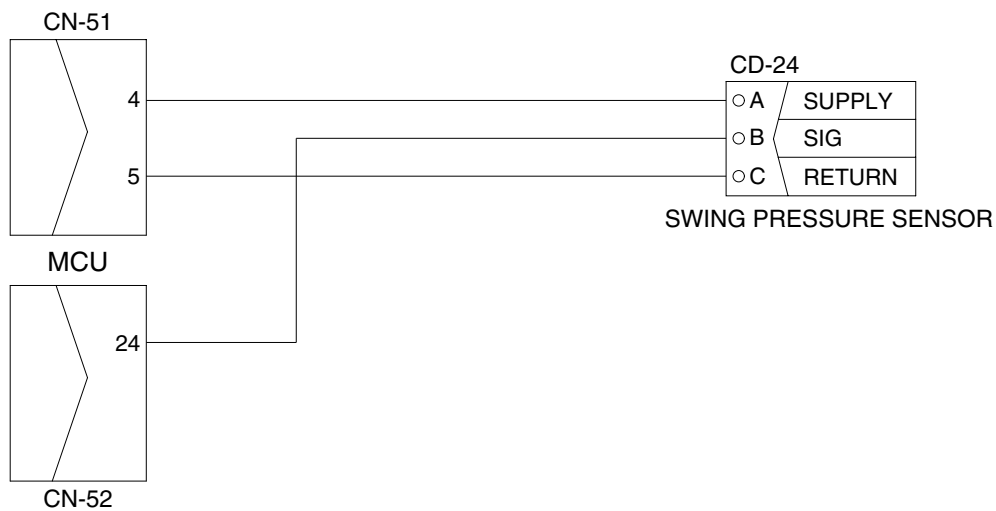

21096MS11

2) TEST PROCEDURE

(1) Test 14 : Check voltage at CN-52(24) and ground.

- ① Prepare 1 piece of thin sharp pin, steel or copper.
- ② Insert prepared pin to rear side of connectors : One pin to (24) of CN-52.
- ③ Starting key ON.
- ④ Check voltage as figure.

SPEC : Actuator operating : 1~5 V

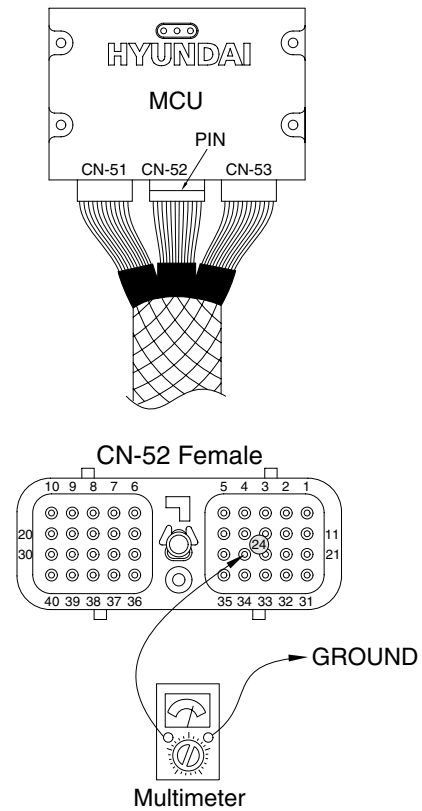

21096MS11A

12. MALFUNCTION OF ARM IN/OUT & BUCKET IN PRESSURE SENSOR

· Fault code : HCESPN 133, FMI 0~4

※ Before carrying out below procedure, check all the related connectors are properly inserted.

1) INSPECTION PROCEDURE

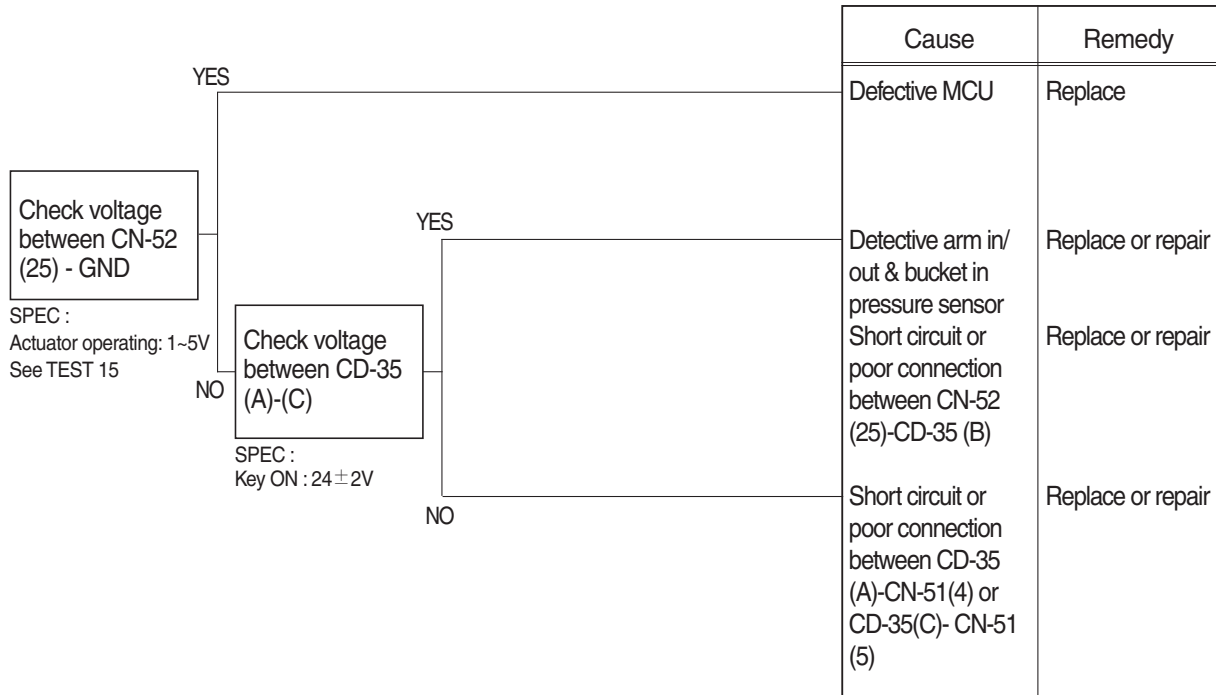

Wiring diagram

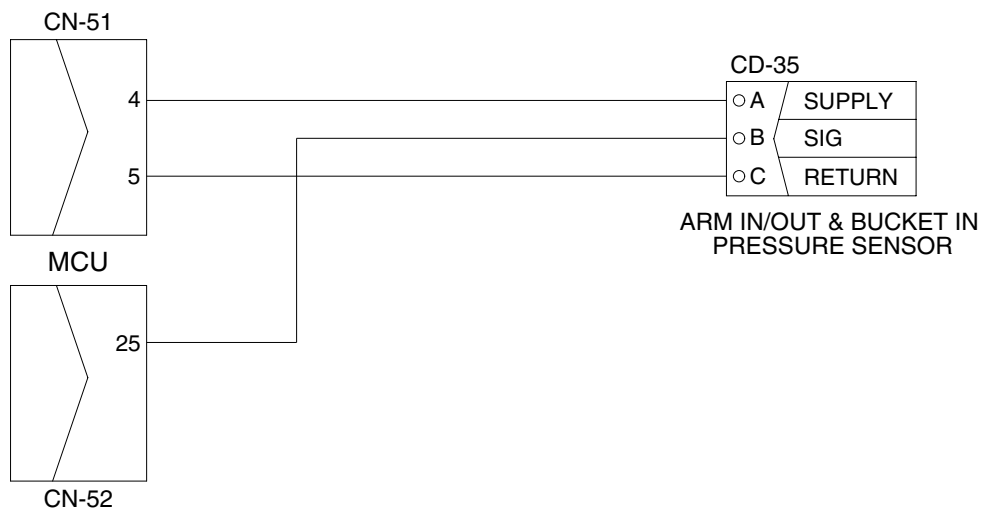

21096MS12

2) TEST PROCEDURE

(1) **Test 15** : Check voltage at CN-52(25) and ground.

- ① Prepare 1 piece of thin sharp pin, steel or copper.
- ② Insert prepared pin to rear side of connectors : One pin to (25) of CN-52.
- ③ Starting key ON.
- ④ Check voltage as figure.

SPEC : Actuator operating : 1~5 V

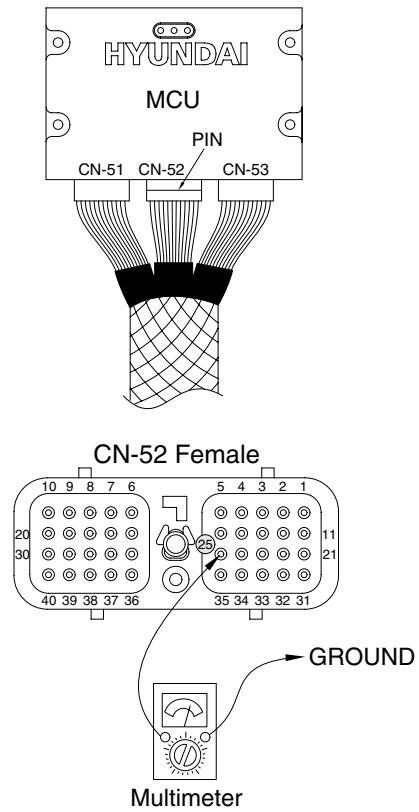

21096MS12A

13. MALFUNCTION OF BOOM UP PRESSURE SENSOR

· Fault code : HCESPN 127, FMI 0~4

※ Before carrying out below procedure, check all the related connectors are properly inserted.

1) INSPECTION PROCEDURE

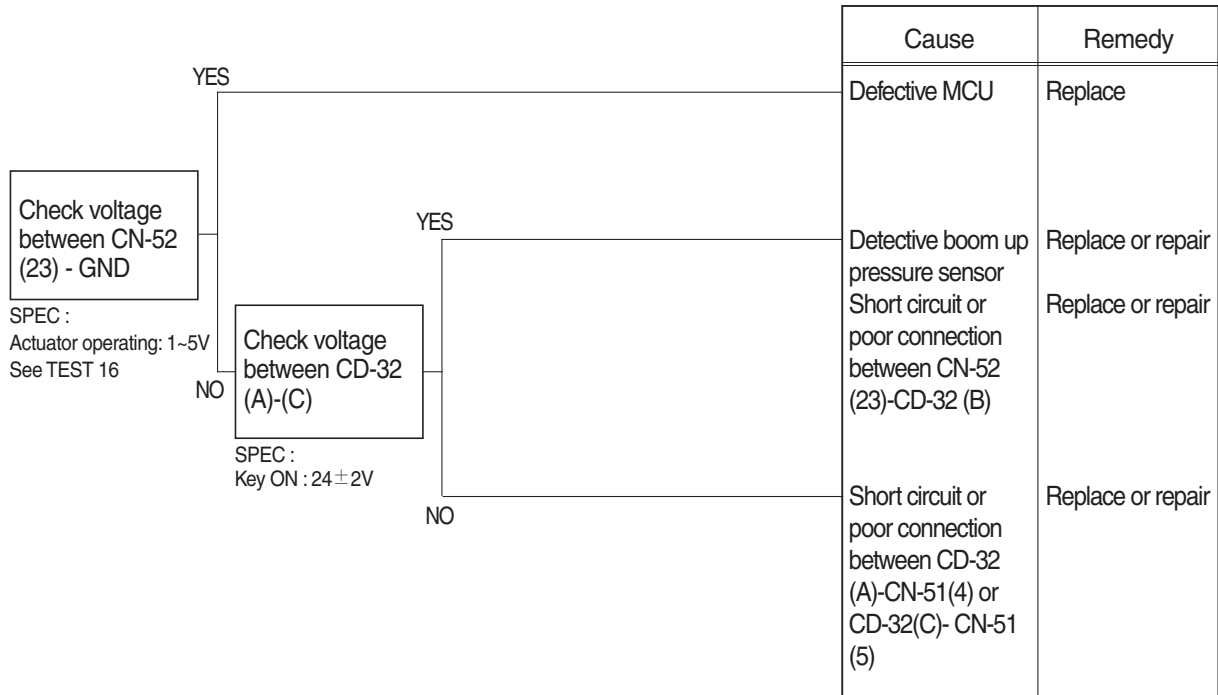

Wiring diagram

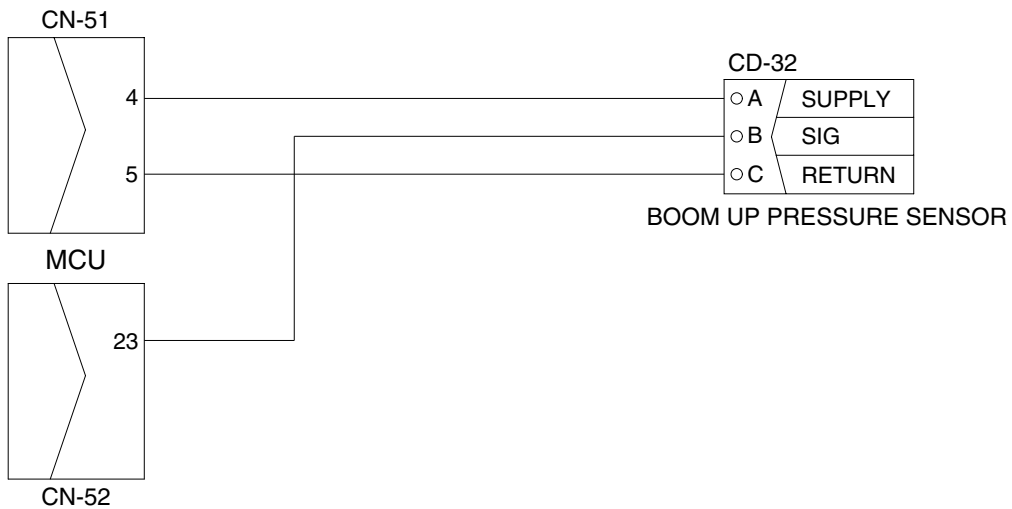

21096MS13

2) TEST PROCEDURE

(1) **Test 16** : Check voltage at CN-52(23) and ground.

- ① Prepare 1 piece of thin sharp pin, steel or copper.
- ② Insert prepared pin to rear side of connectors : One pin to (23) of CN-52.
- ③ Starting key ON.
- ④ Check voltage as figure.

SPEC : Actuator operating : 1~5 V

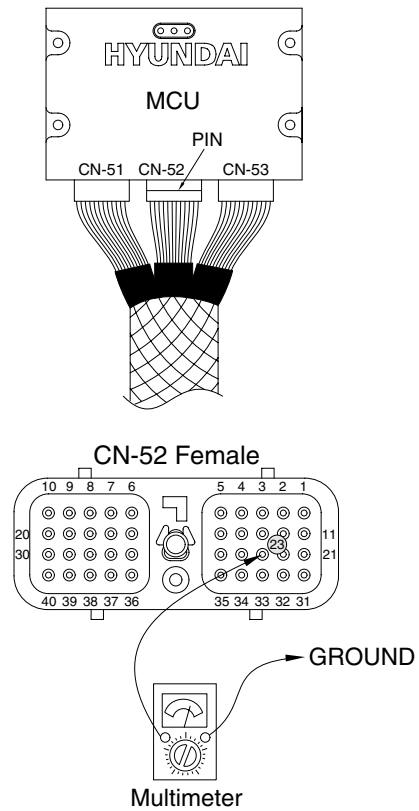

21096MS13A

14. MALFUNCTION OF POWER MAX

· Fault code : HCESPN 166, FMI 5 or 6

※ Before carrying out below procedure, check all the related connectors are properly inserted.

1) INSPECTION PROCEDURE

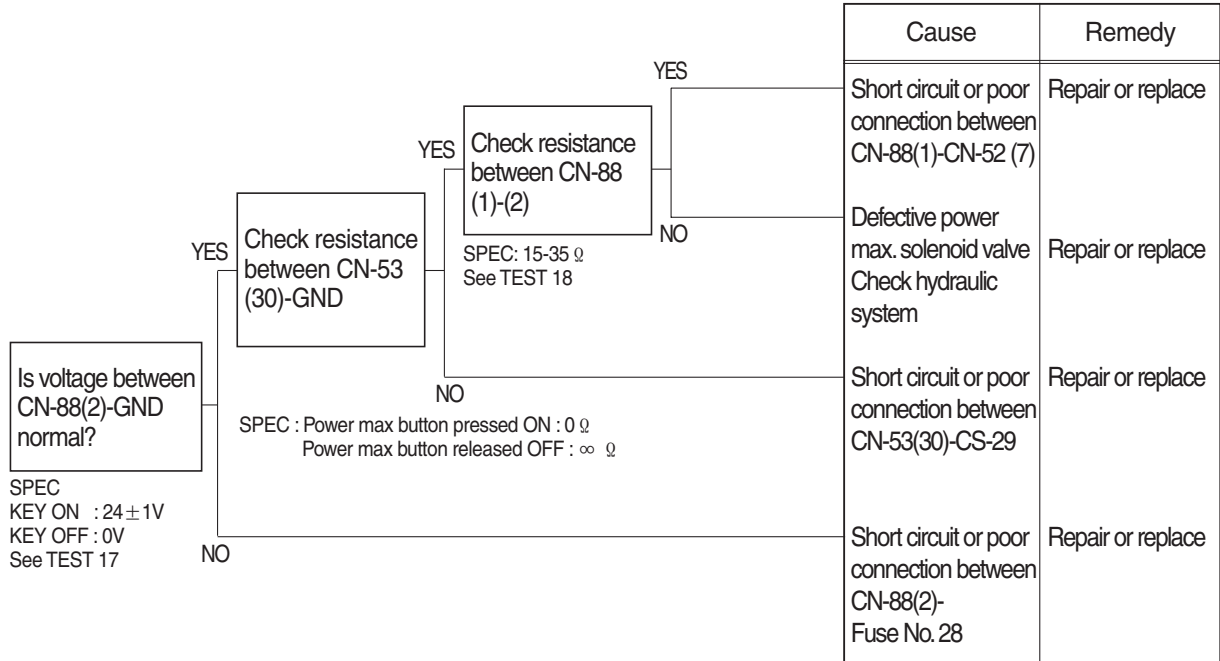

Wiring diagram

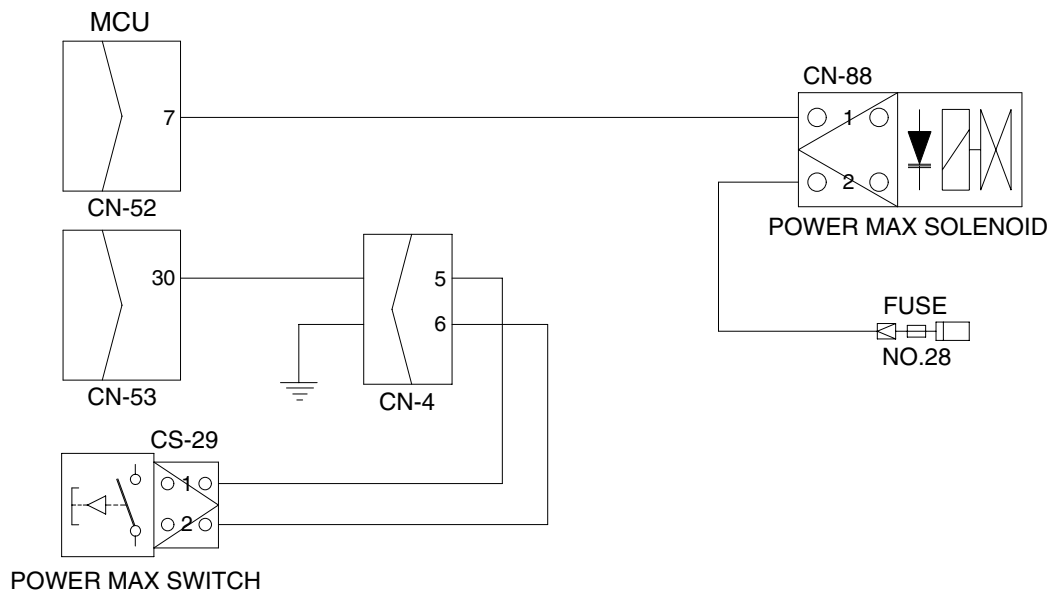

21096MS14

2) TEST PROCEDURE

(1) **Test 17:** Check voltage between connector CN-88(2) - GND.

- ① Disconnect connector CN-88 from power max solenoid valve.
- ② Start key ON.
- ③ Check voltage as figure.

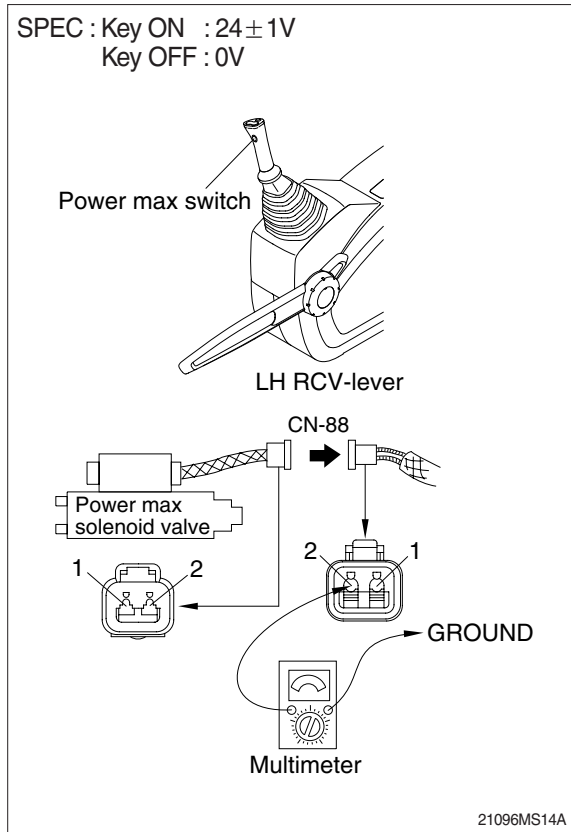

(2) **Test 18:** Check resistance of the solenoid valve between CN-88(1)-(2).

- ① Starting key OFF.
- ② Disconnect connector CN-88 from power max solenoid valve.
- ③ Check resistance as figure.

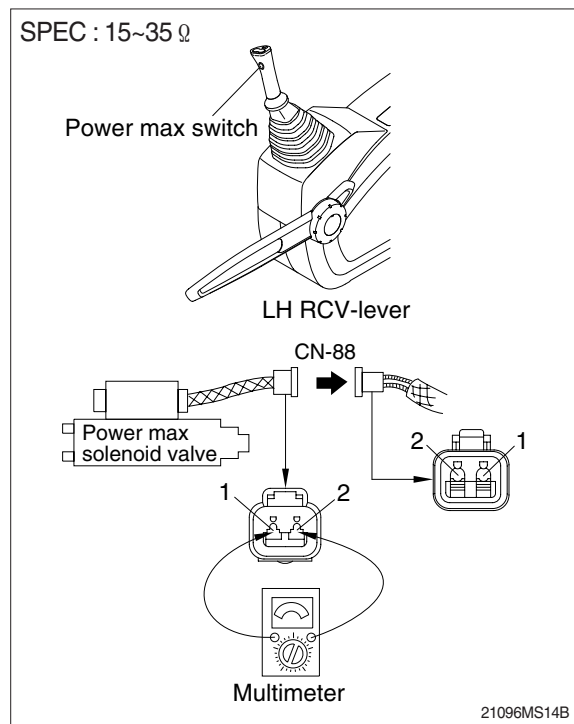

15. MALFUNCTION OF BOOM PRIORITY EPPR VALVE

· Fault code : HCESPN 141, FMI 5 or 6

※ Before carrying out below procedure, check all the related connectors are properly inserted.

1) INSPECTION PROCEDURE



Wiring diagram

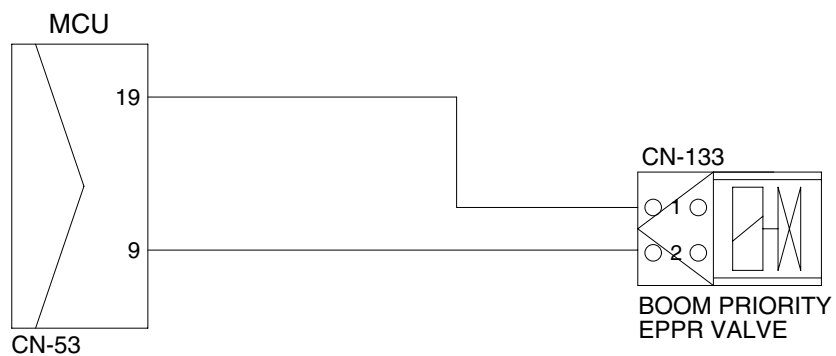

21096MS15

16. MALFUNCTION OF ARM REGENERATION SOLENOID

· Fault code : HCESPN 170, FMI 5 or 6

※ Before carrying out below procedure, check all the related connectors are properly inserted.

1) INSPECTION PROCEDURE

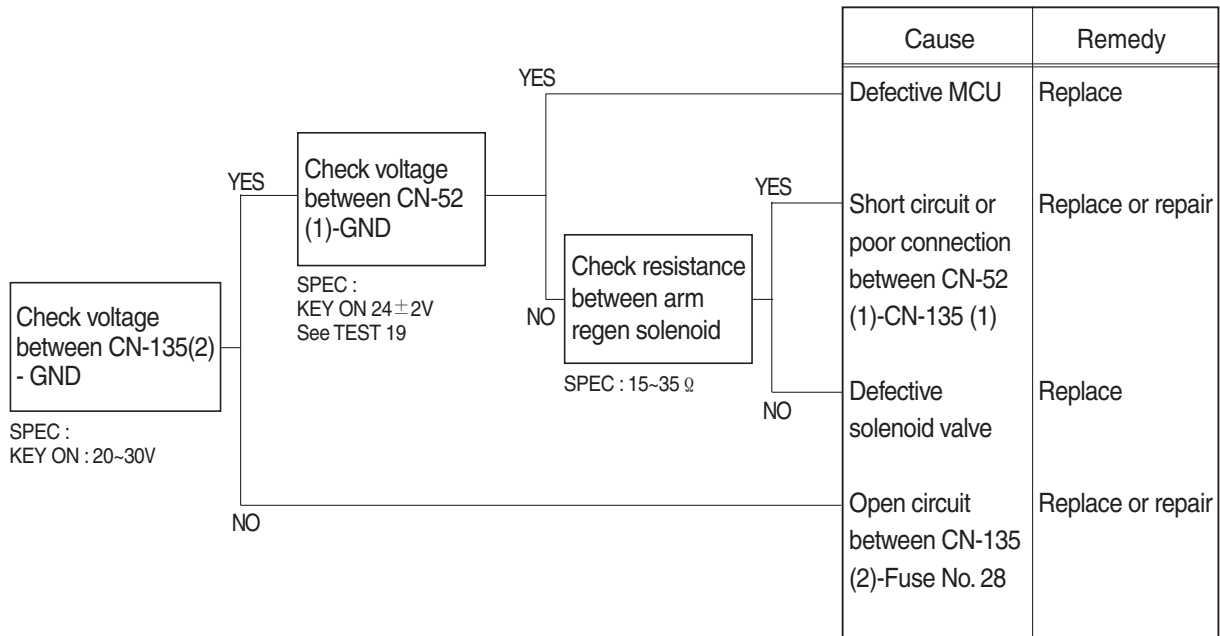

Wiring diagram

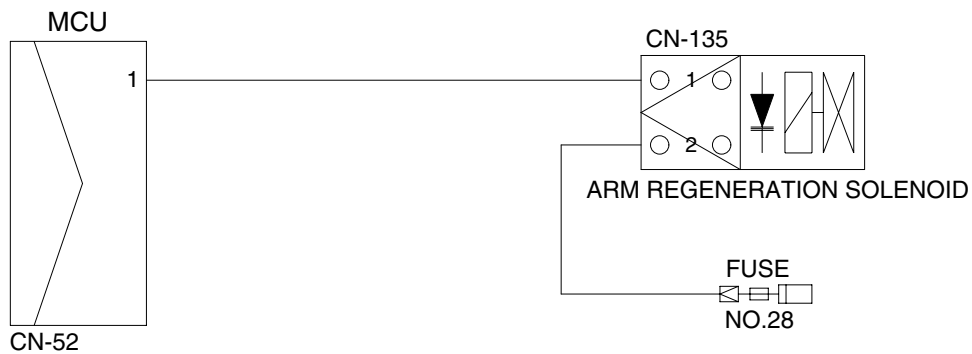

21096MS16

2) TEST PROCEDURE

(1) **Test 19** : Check voltage at CN-52(1) and ground.

- ① Prepare 1 piece of thin sharp pin, steel or copper.
- ② Insert prepared pin to rear side of connectors : One pin to (1) of CN-52.
- ③ Starting key ON.
- ④ Check voltage as figure.

SPEC : Key ON : 24 ± 2 V

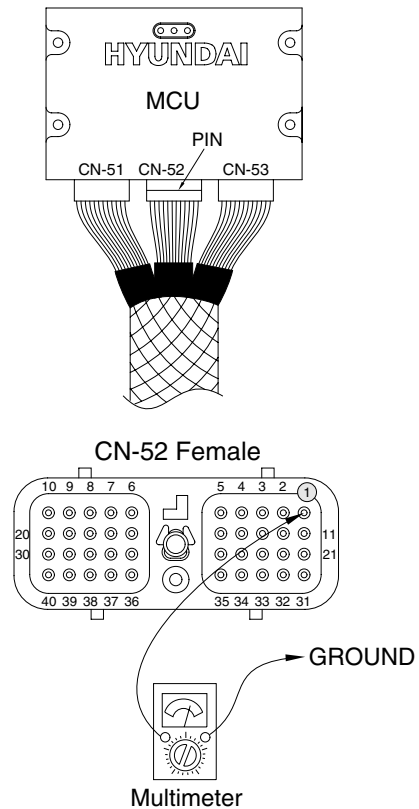

21096MS16A