

GROUP 7 WORK EQUIPMENT

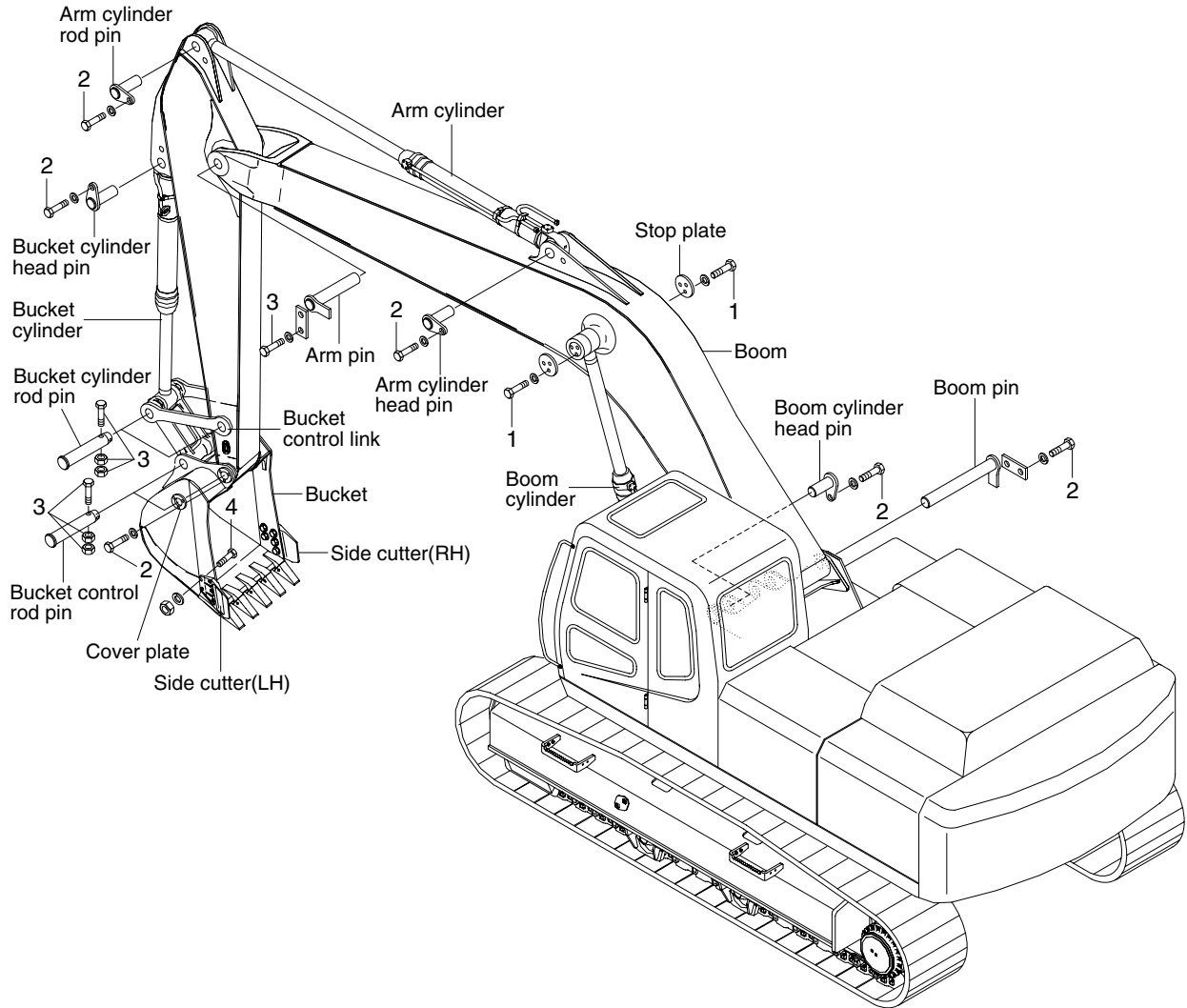

29079CM13

· Tightening torque

Item	Size	kgf · m	lbf · ft
1	M12×1.75	12.8±3.0	92.6±21.7
2	M16×2.0	29.7±4.5	215±32.5

Item	Size	kgf · m	lbf · ft
3	M20×2.5	57.9±8.7	419±62.9
-	M22×2.5	55.8±7.5	404±54.2