

## GROUP 6 TRAVEL DEVICE

### 1. REMOVAL AND INSTALL

#### 1) REMOVAL

- (1) Swing the work equipment 90° and lower it completely to the ground.
- (2) Operate the control levers and pedals several times to release the remaining pressure in the hydraulic piping.
- (3) Loosen the breather slowly to release the pressure inside the hydraulic tank.
- ▲ Escaping fluid under pressure can penetrate the skin causing serious injury.
- ※ When pipes and hoses are disconnected, the oil inside the piping will flow out, so catch it in oil pan.
- (4) Remove the track shoe assembly.  
For details, see **removal of track shoe assembly**.
- (5) Remove the cover.
- (6) Remove the hose.  
※ Fit blind plugs to the disconnected hoses.
- (7) Remove the bolts and the sprocket.
- (8) Sling travel device assembly(1).
- (9) Remove the mounting bolts(2), then remove the travel device assembly.  
· Weight : 300kg(660lb)

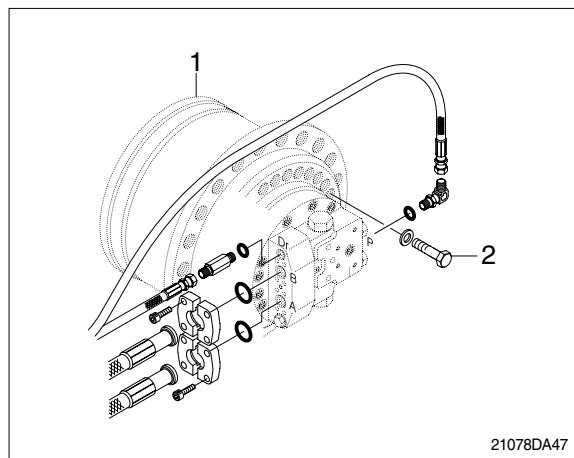

#### 2) INSTALL

- (1) Carry out installation in the reverse order to removal.
- (2) Bleed the air from the travel motor.
  - ① Remove the air vent plug.
  - ② Pour in hydraulic oil until it overflows from the port.
  - ③ Tighten plug lightly.
  - ④ Start the engine, run at low idling, and check oil come out from plug.
  - ⑤ Tighten plug fully.
- (3) Confirm the hydraulic oil level and check the hydraulic oil leak or not.

## 2. TRAVEL MOTOR

### 1) STRUCTURE

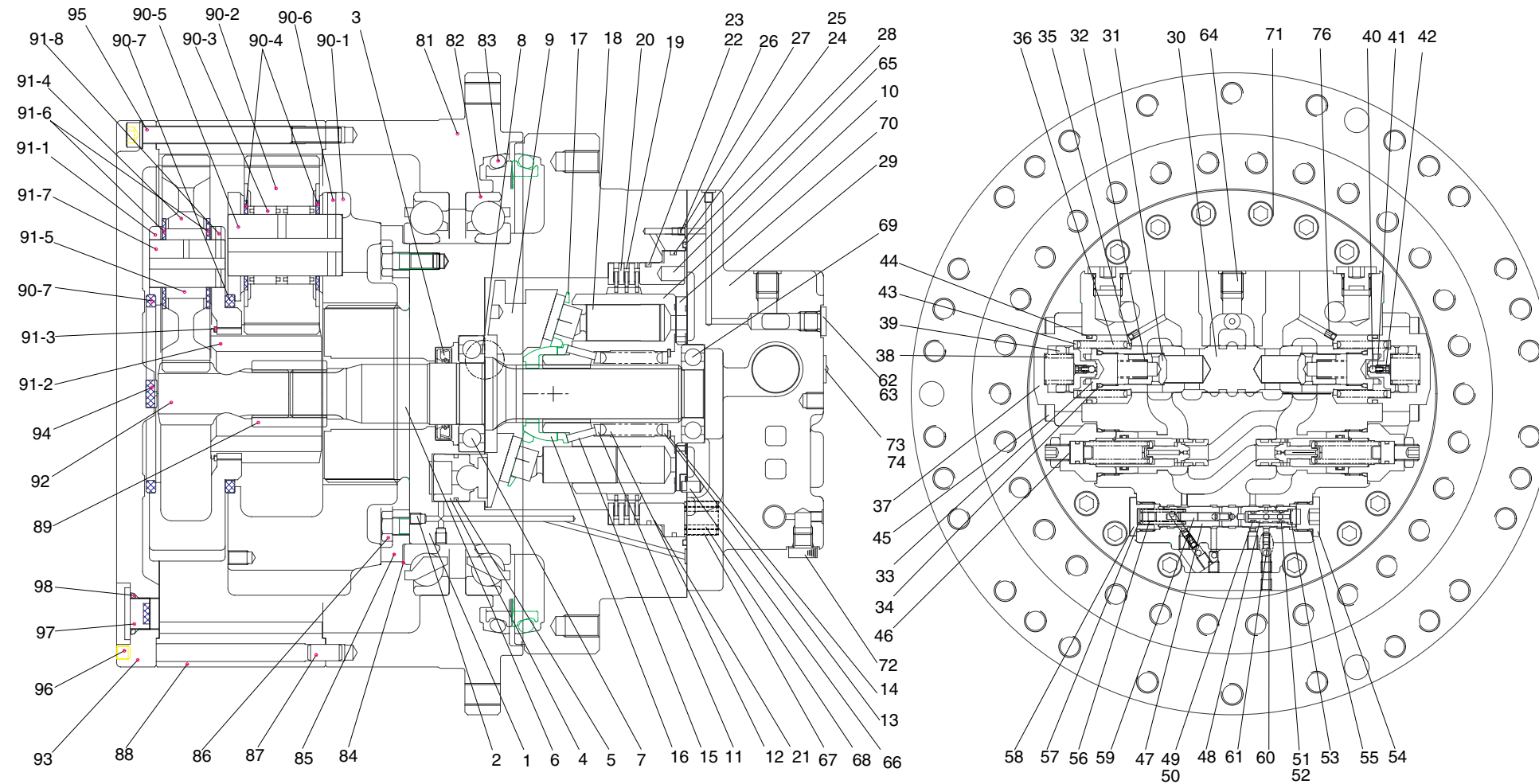

1 Shaft casing	20 Plate	39 Spool	57 Spring seat	75 Seal kit	90-7 Thrust ring
2 Plug	21 Packing piston	40 Steel ball	58 Plug	76 Orifice	91 Carrier assy No.1
3 Oil seal	22 O-ring	41 Spring	59 Spool	81 Housing	91-1 Carrier No.1
4 Swash piston	23 Back up ring	42 Plug	60 Orifice	82 Main bearing	91-2 Sun-gear No.2
5 Piston ring	24 O-ring	43 Spring seat	61 Orifice	83 Floating seal	91-3 Retaining ring
6 Shaft	25 Back up ring	44 O-ring	62 Plug	84 Shim	91-4 Planetary gear No.1
7 Bearing	26 Orifice	45 Wrench bolt	63 O-ring	85 Retainer	91-5 Needle bearing No.1
8 Steel ball	27 O-ring	46 Relief valve assy	64 Plug	86 Hex head bolt	91-6 Thrust washer
9 Swash plate	28 O-ring	47 Spool	65 Pin	87 Parallel pin	91-7 Pin No.1
10 Cylinder block	29 Rear cover	48 Guide	66 Pin	88 Ring gear	91-8 Spring pin
11 Spring seat	30 Spool	49 O-ring	67 Spring	89 Coupling	92 Sun gear No.1
12 Spring	31 Check	50 Back up ring	68 Spring	90 Carrier assy No.2	93 Cover
13 End plate	32 Spring	51 O-ring	69 Bearing	90-1 Carrier No.2	94 Pad
14 Snap ring	33 Plug	52 Back up ring	70 Valve plate	90-2 Planetary gear No.2	95 Hex socket head bolt
15 Pin	34 O-ring	53 Snap ring	71 Wrench bolt	90-3 Needle bearing No.2	96 Hex socket Screw
16 Ball guide	35 Spring seat	54 plug	72 Plug	90-4 Thrsut washer	97 Hydraulic plug
17 Set plate	36 Spring	55 O-ring	73 Name plate	90-5 Pin No.2	98 O-ring
18 Piston assy	37 Cover	56 Spring	74 Rivet	90-6 Spring pin	99 Name plate
19 Friction plate	38 Spring				

21078TM02

## 2) TOOLS AND TIGHTENING TORQUE

### (1) Tools

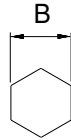
Tool name		Remark	
Allen wrench		2.5, 4, 6, 10	
Socket for socket wrench, spanner	Socket	8, 14, 24, 27	
Torque wrench		Capable of tightening with the specified torques	
Pliers		-	
Plastic and iron hammer		Wooden hammer allowed. Normal 1 or so	
Monkey wrench		-	
Oil seal inserting jig		-	
Bearing pliers		-	
Seal tape		-	
Eye bolt		M10, M12, M14	
Press(0.5 ton)		-	
Oil stone		-	
Bearing assembling jig		-	

### (2) Tightening torque

Part name	Item	Size	Torque	
			kgf · m	lbf · ft
Plug	2	NPTF 1/16	1±0.1	7.2±0.7
Orifice	26	M5	0.7±0.1	5±0.7
Wrench bolt	45	M12×40L	10±1.0	72±7.0
Relief valve	46	HEX 27	18±1.0	130±7.0
Plug	54	PF 1/2	8.5±1.0	61±7.0
Plug	58	HEX 24	5±1.0	36±7.0
Plug	62	PF 1/4	5±1.0	36±7.0
Wrench bolt	71	M10×35L	10±1.0	72±7.0
Hex head bolt	-	M12×25L	11±1.5	79±10
Hex socket head bolt	-	M12×155L	11±1.5	79±10
Hex socket head plug	-	PF 3/4	19±1	137±7.0

### 3. OUTLINE OF DISASSEMBLING

#### 1) GENERAL SUGGESTIONS

- (1) Select a clean place for dismantling.  
Spread a rubber plate on a working table in order to prohibit the damage of parts.
- (2) Clean a deceleration equipment and a motor part, washing out dirt and unnecessary substances.
- (3) Without any damage of O-ring, oil seal, the adhered surface of other seals, a gear, a pin, the adhered surface of other bearings, and the surface of moisturized copper, treat each parts.
- (4) Numbers written in the parenthesis, ( ), next to the name of a part represent the part numbers of a cross-sectional view annexed with a drawing.
- (5) The side of a pipe in a motor can be written as a rear side; the side of out-put as a front side.
- (6) Using and combining a liquid gasket, both sides must be dried completely before spraying a liquid gasket.
- (7) In case of bonding volts, combine a standard torque by torque wrench after spraying loctite 262 on the tab parts. (It can be dealt as assembling NPTF screws and an acceleration equipment.)

#### 3.1 DISASSEMBLING

- 1) Unloosing wrench bolt and disassemble cover(37).  
※ Wrench bolt = M12×40L-8EA  
(Purchasing goods)

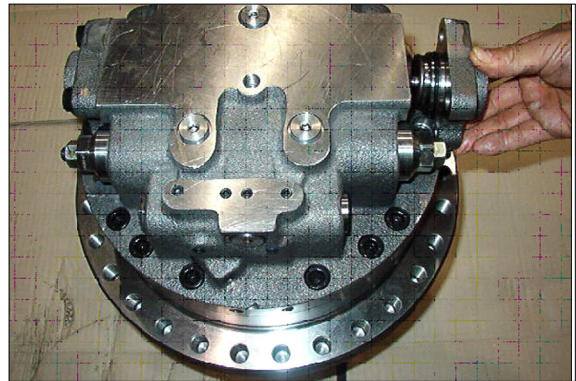

21078TM21

- 2) Disassemble parts related to C.B.V.

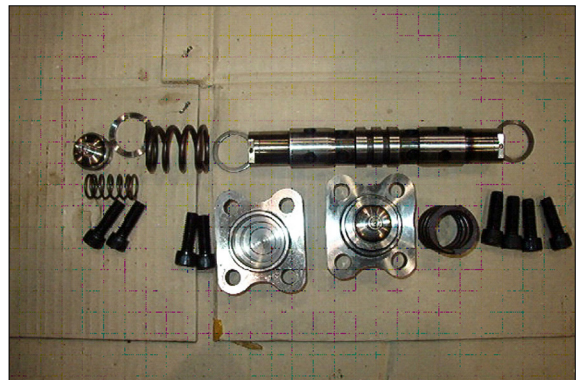

21078TM22

- 3) Unloosing wrench bolt(M12×35L, 16EA) and disassemble rear cover assembly from motor assembly.

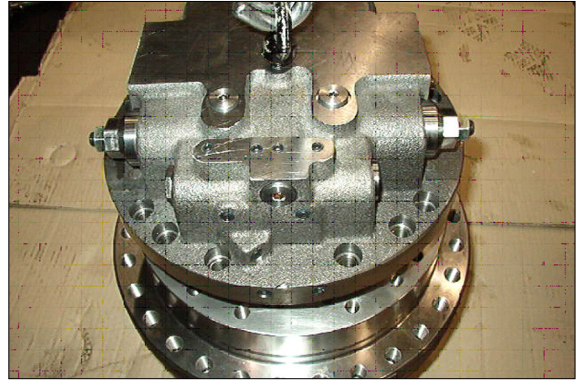

21078TM23

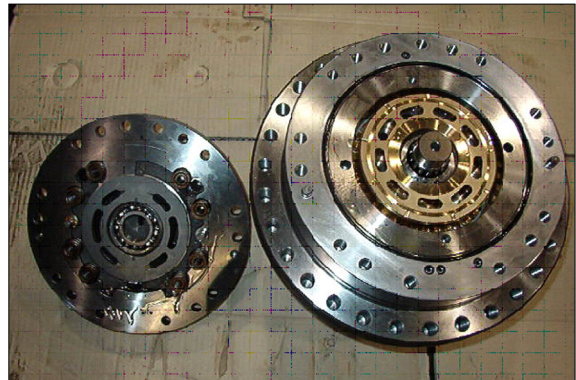

21078TM24

- 4) Dismantle packing piston(21) using compressed air.

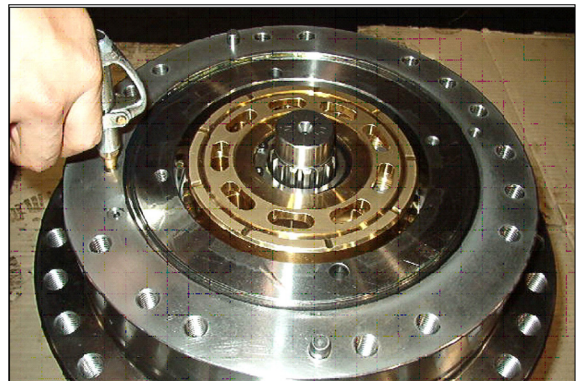

21078TM25

- 5) Disassembly rotary kit from motor assembly(Cylinder block assembly, piston assembly, ball guide, set plate, friction plate, steel plate...)

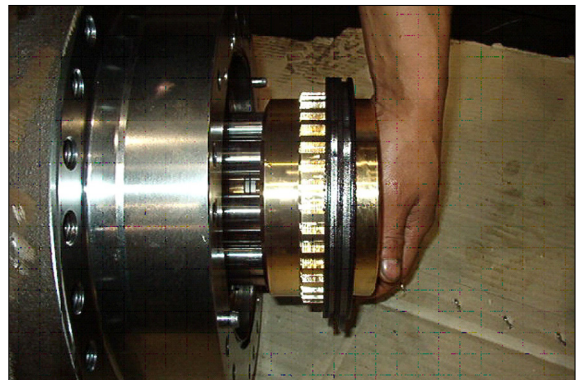

21078TM26

6) Using a jig, disassemble swash plate(9) from shaft casing.

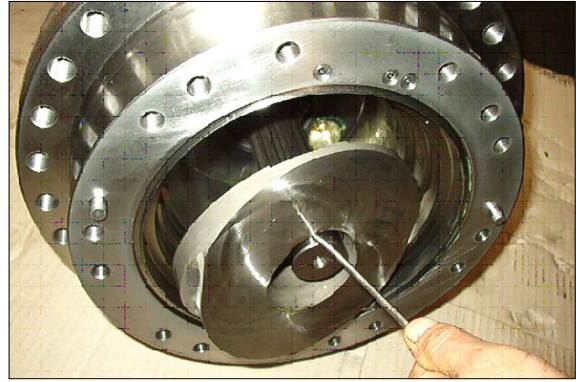

21078TM27

7) Using compressed air, disassemble piston swash(4) piston ring(5), respectively.

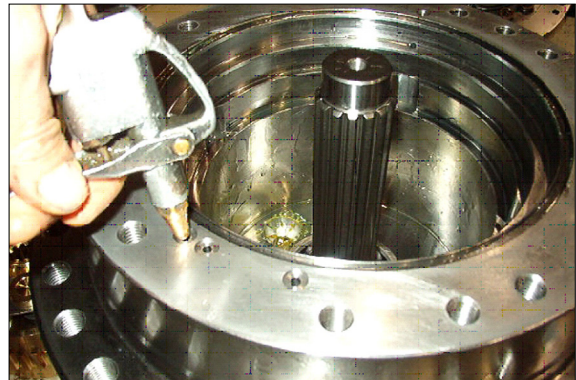

21078TM28

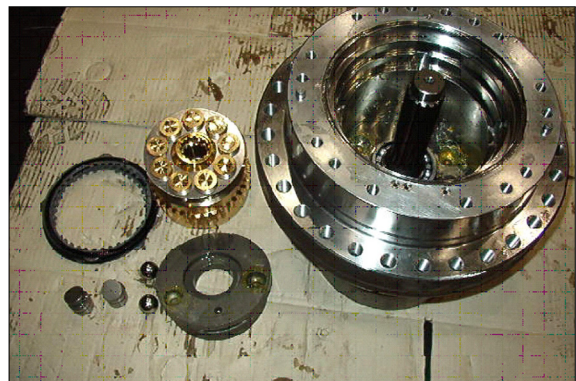

21078TM29

8) Using a hammer, disassemble shaft(6) from shaft casing(1).

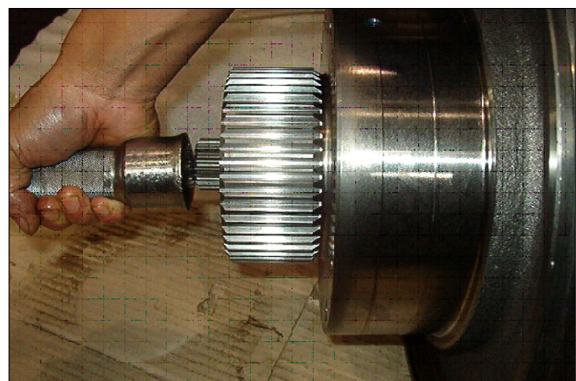

21078TM30

■ Disassemble cylinder sub.

9) Disassemble cylinder block assembly, piston assembly(9) and seat plate(M).

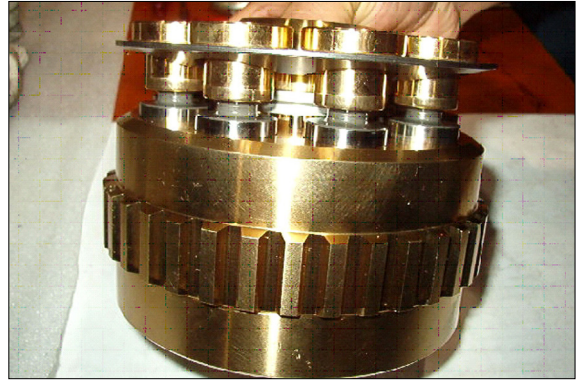

21078TM31

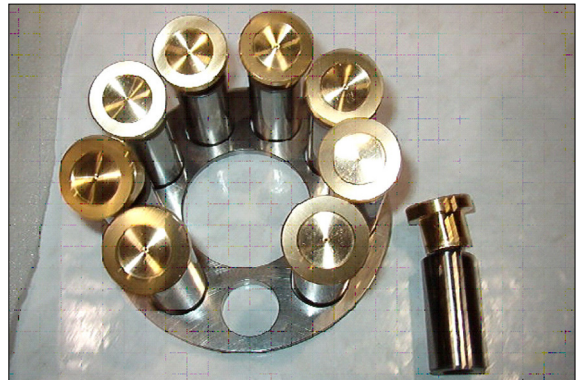

21078TM32

10) Disassemble ball guide(16), ring and pin(15) from cylinder block, respectively.

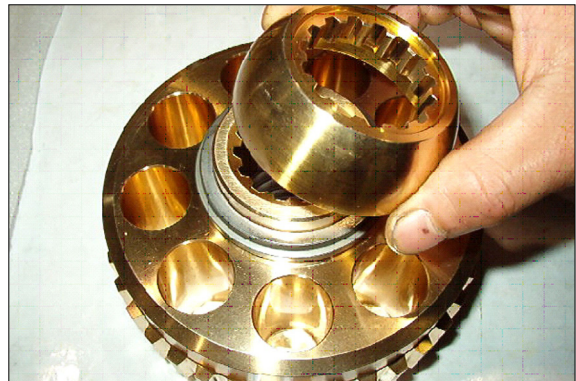

21078TM33

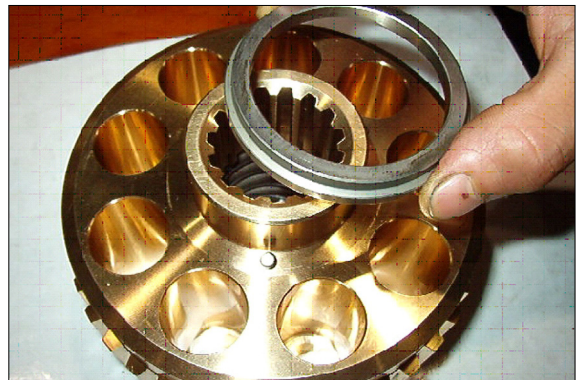

21078TM34

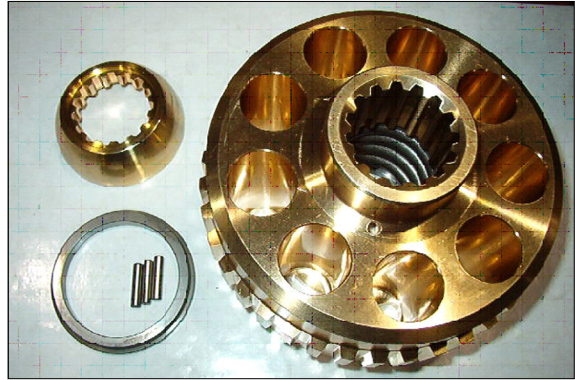

21078TM35

11) Pushing spring(12) by an assembling jig, disassemble snap ring(14), spring seat(13), spring(12) and spring seat(11), respectively.

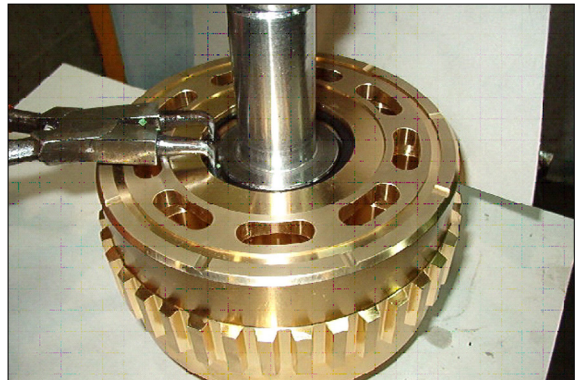

21078TM36



21078TM37

■ **Disassemble valve casing sub.**

12) Using an hexagon wrench, unloosing wrench bolt(45) and disassemble cover(37), spring(38), spool(39), spring seat(43), spring(36) and spring seat(35), respectively. (Same balance on both sides)

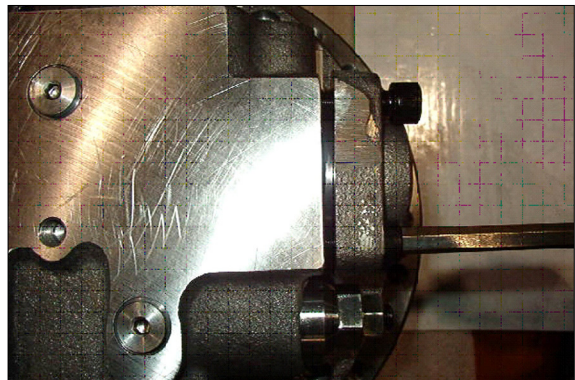

21078TM38



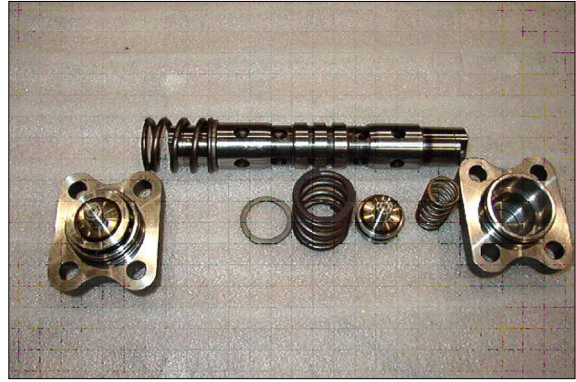

21078TM39

13) Disassemble spool(59), spool(47), O-ring (51), guide(48) and snap ring(53) on rear cover, respectively.

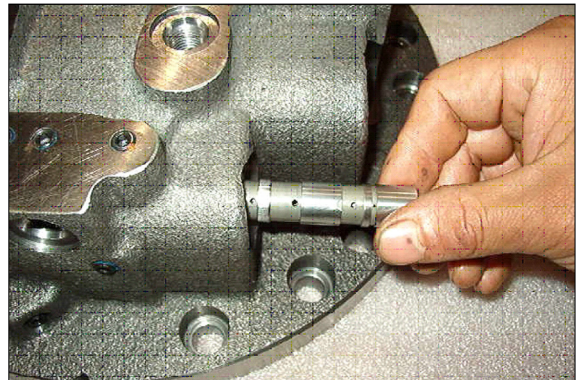

21078TM40



21078TM41

14) Using a torque wrench, disassemble relief assembly(46) on rear cover.

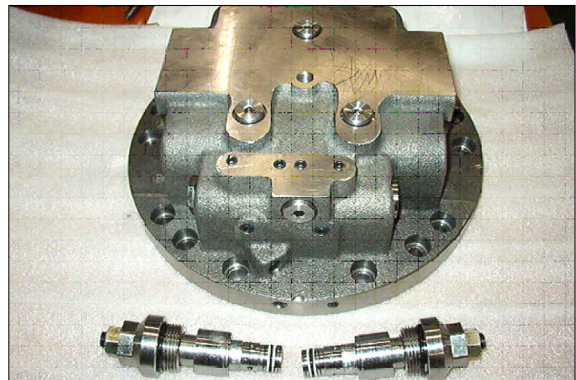

21078TM42

## 4. OUTLINE FOR ASSEMBLING

### 1) GENERAL SUGGESTIONS

- (1) After washing each parts cleanly, dry it with compressed air.  
Provided that you do not wash friction plate with treated oil.
- (2) In bonding each part, fasten bond torque.
- (3) When using a hammer, do not forget to use a plastic hammer.

### 4.1 ASSEMBLING

- Assemble the sub of turning axis

- 1) Using a jig, assemble oil seal(3) into shaft casing(1)

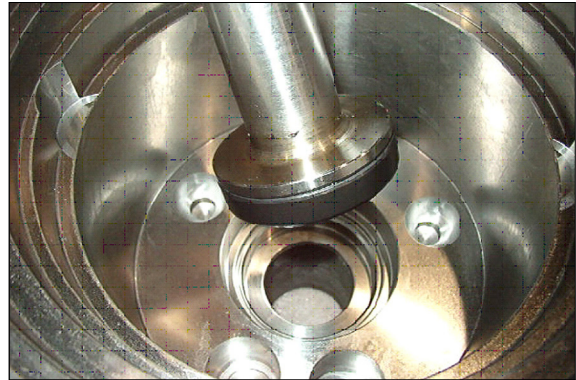

21078TM43

- 2) Have a bearing(8) thermal reacted into shaft(6).



21078TM44

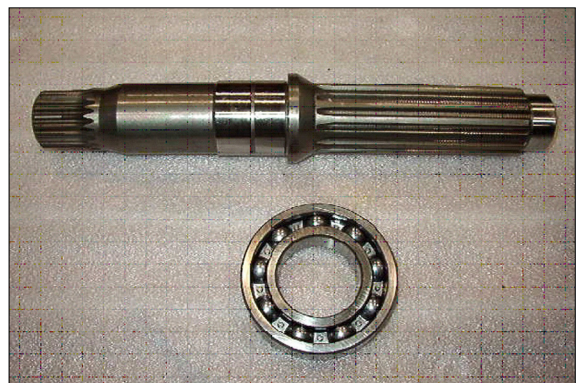

21078TM45

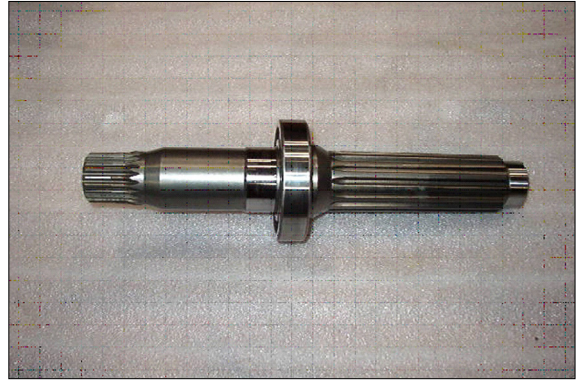

21078TM46

3) Using a jig, assemble shaft assembly into shaft casing(1).

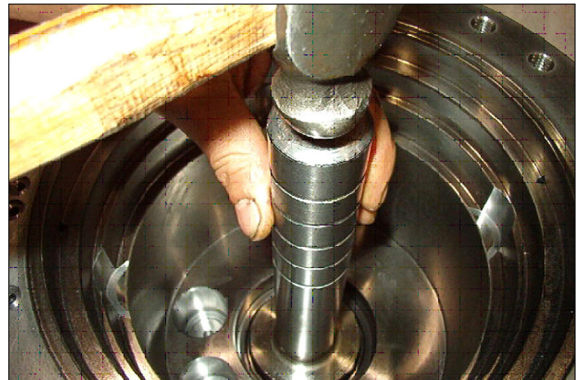

21078TM47

4) After spreading grease on steel ball(8) assemble into shaft casing(1).

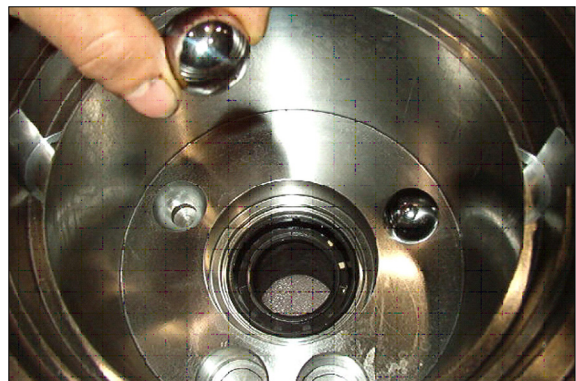

21078TM48

5) Assemble swash piston assembly(4, 5) into shaft casing(1).



21078TM49

- 6) Assemble swash plate(9) into shaft casing (1).

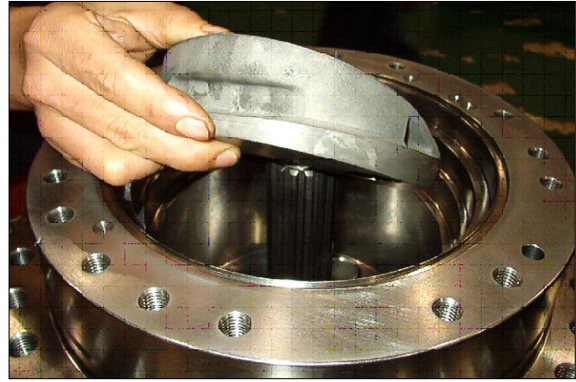

21078TM50

■ Assemble cylinder block sub.

- 7) Assemble spring seat(13), spring(12), spring seat(11) into cylinder block(10) respectively, pushing spring(12) using by a jig, assemble snap ring(14) with a snap ring(14).



21078TM51

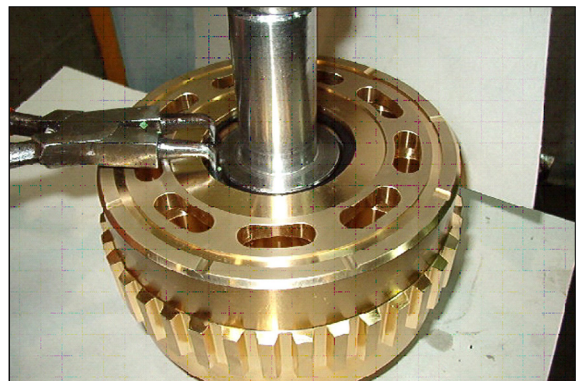

21078TM52

8) Assemble ring, pin(15) on cylinder block(10) ball guide(16) respectively.

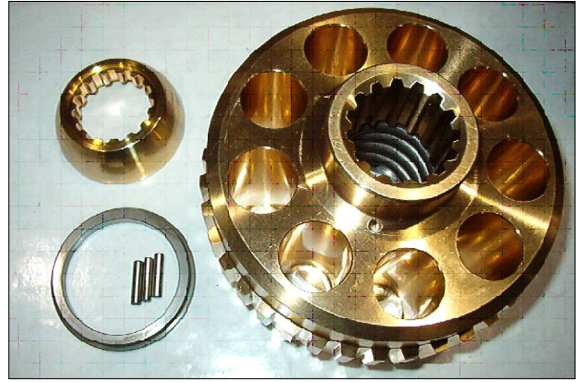

21078TM53

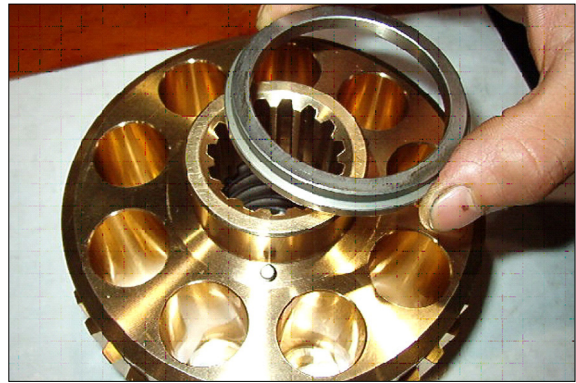

21078TM54

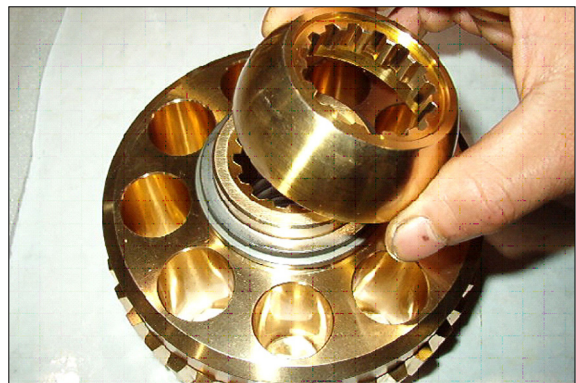

21078TM55

9) Assemble cylinder block assembly, piston assembly(9), seat plate(17).

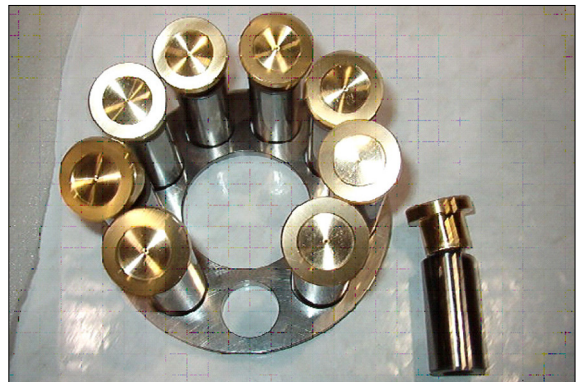

21078TM56

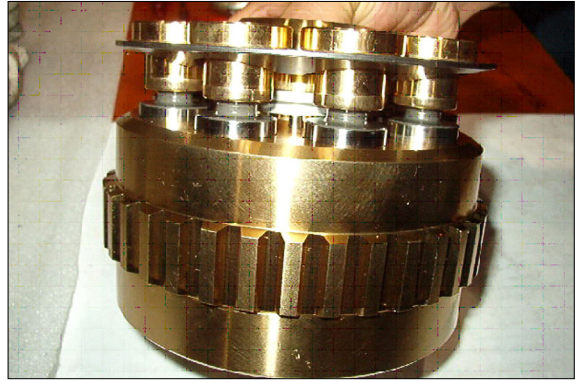

21078TM57

10) Assemble cylinder block assembly(9) into shaft casing(a).

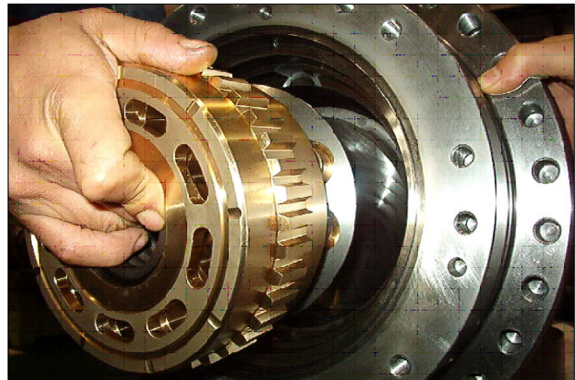

21078TM58

11) Assemble friction plate(19) and plate(20) into shaft casing(1) respectively, prepare 6 set.

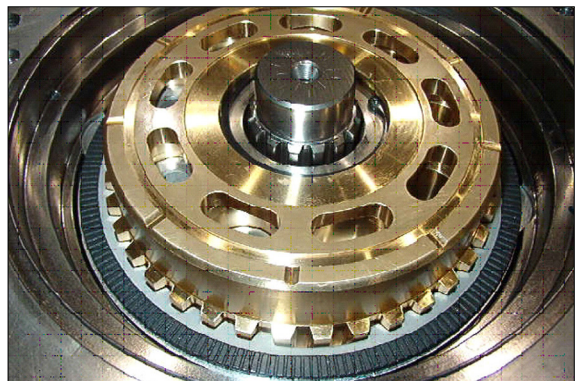

21078TM59



21078TM59-1

12) Assemble O-ring(22, 23) into packing piston (21).

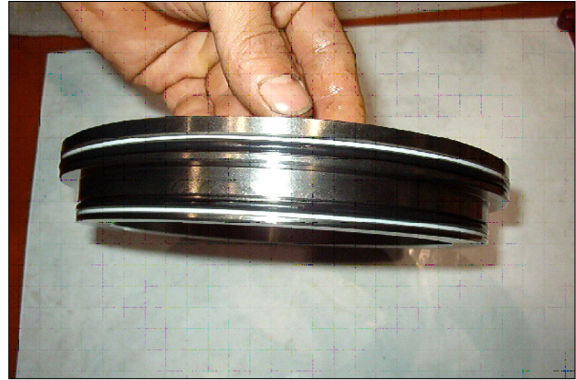

21078TM60

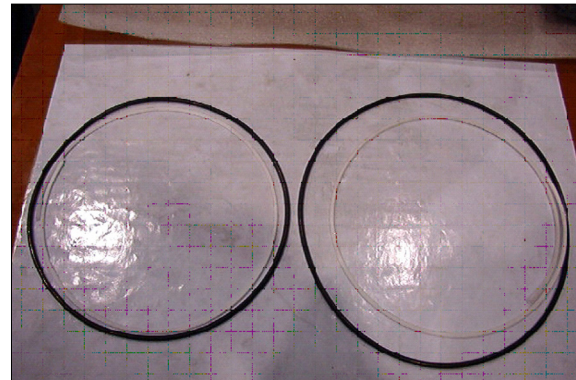

21078TM60-1

13) After spreading grease on packing piston(21) bond wrench bolt and assemble shaft casing(1).

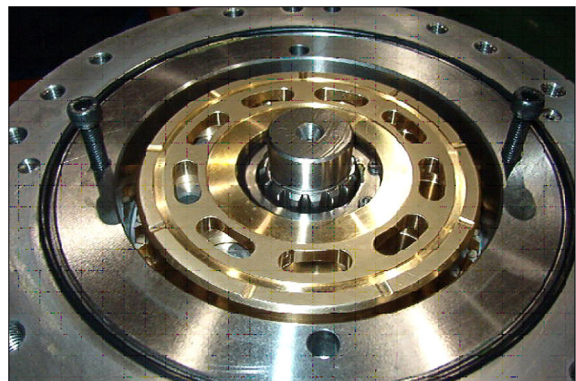

21078TM61

■ Assemble rear cover sub.

14) Using a jig, assemble bearing(69) into rear cover(29).

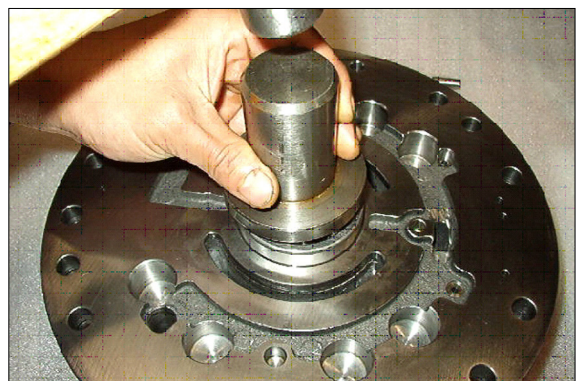

21078TM62

15)After assembling spool(59), spool(47), O-ring(51), guide(48) and snap ring(53) respectively into rear cover(29). Using torque wrench, assemble it.



21078TM63

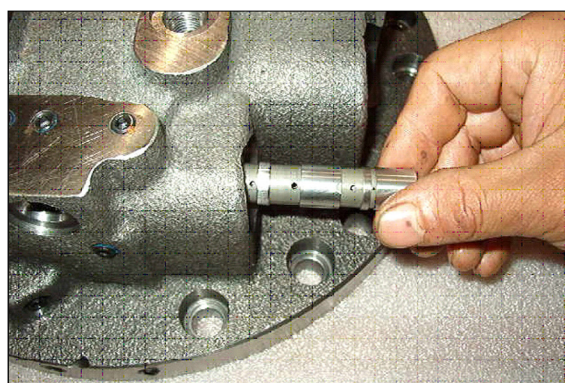

21078TM64

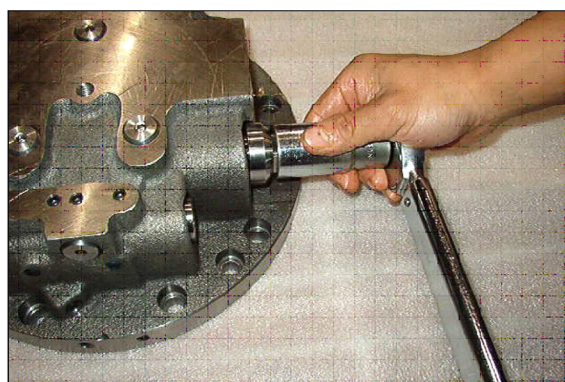

21078TM65



16) Assemble spring seat(35), spring(36), spring seat(43), spool(39), spring(38), cover(37) respectively and assemble wrench bolt(45).  
(Same balance on both sides)

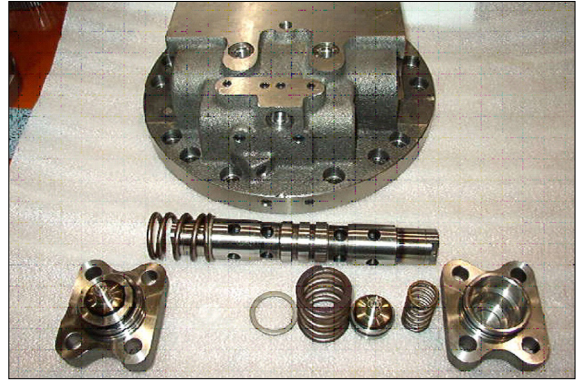

21078TM66

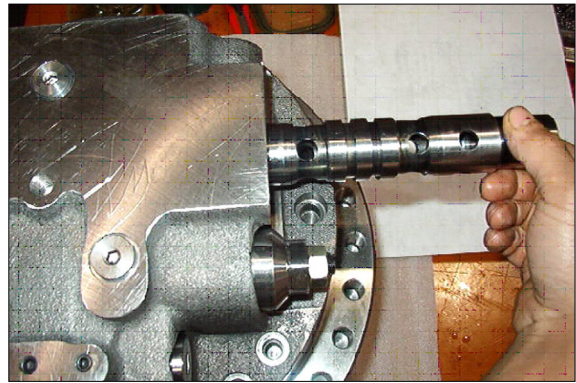

21078TM67

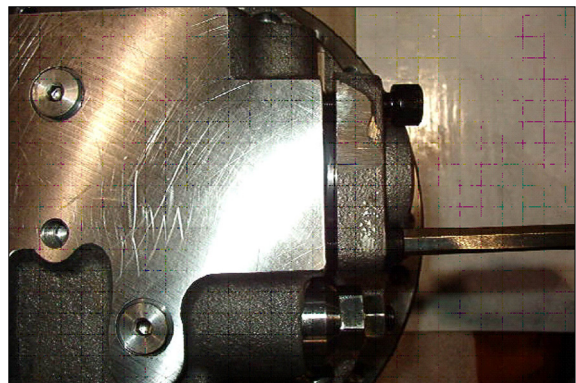

21078TM67-1

17) Assemble plug(2).

※ Plug(NPT1/16) - 11EA

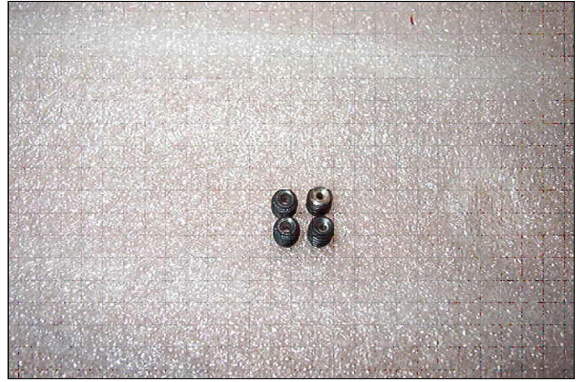

21078TM68

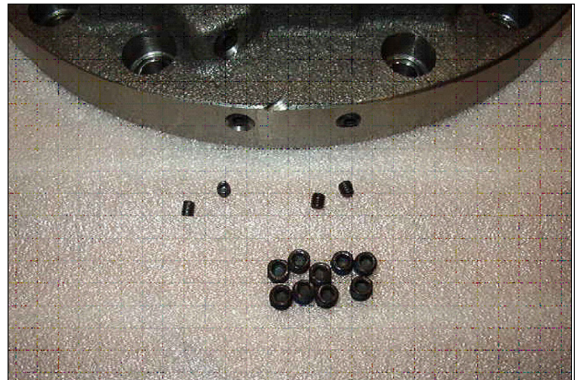

21078TM69

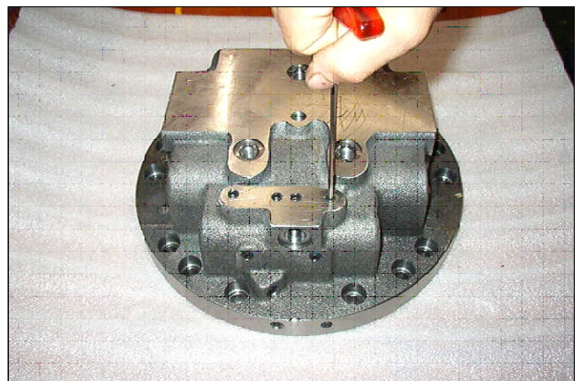

21078TM70



21078TM71

- 18) Assemble plug(64).  
※ Plug(PT3/8) - 11EA

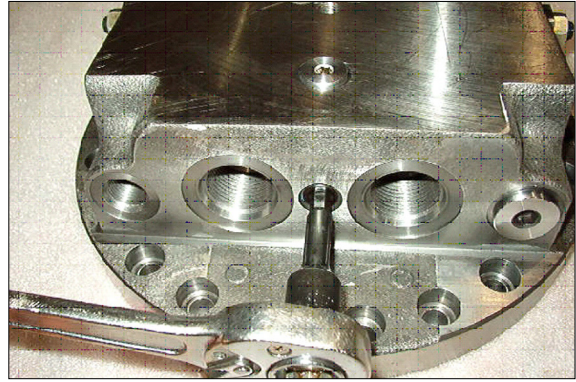

21078TM72

- 19) Assemble plug(62, 63) into rear cover(29)  
and assemble relief valve assembly.

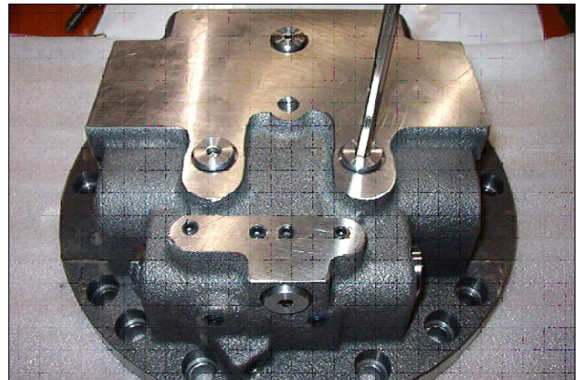

21078TM73

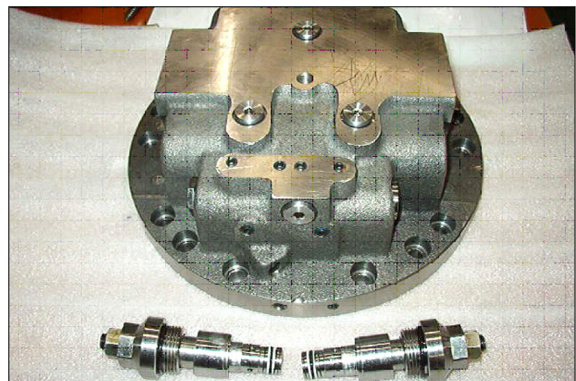

21078TM74

- 20) Put spring(67, 68) together into rear cover  
(29), prepare 6 set.

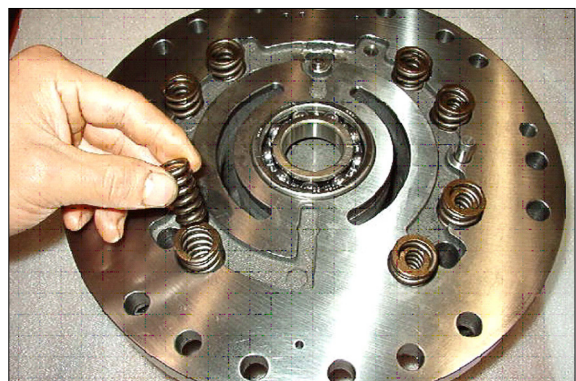

21078TM75



21078TM76

21) Assemble valve plate(70) into rear cover (29).

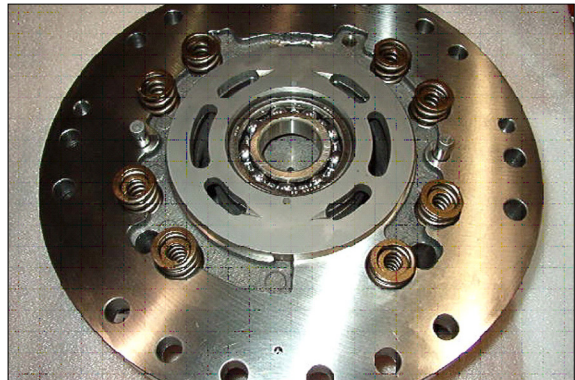

21078TM77

22) After assembling shaft casing(1) and rear cover(29).  
Assemble spool assembly(30), spring(38), spool(39), cover(37) after then complete assembly with wrench bolt(45).

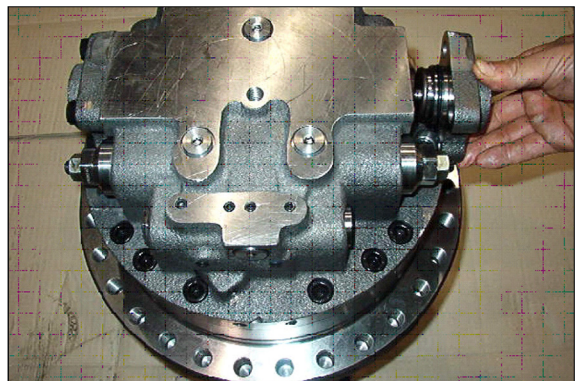

21078TM78

23) Finish assembly.

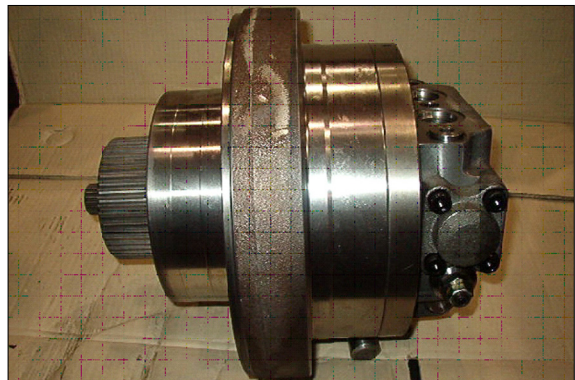

21078TM79

## 5.1 DISASSEMBLING REDUCTION UNIT

### 1) Preparation for disassembling

- (1) The reduction units removed from excavator are usually covered with mud. Wash outside of propelling unit and dry it.
- (2) Locate reducer in order for drain port to be at the lowest level loosen taper screw plug of drain port, and drain oil from reduction gear.
  - ※ While oil is still hot, inside of the unit may be pressurized.

**▲ Take care of the hot oil gushing out of the unit when loosening the plug.**

### (3) Mark for mating

Put marks on each mating parts when disassembling so as to reassemble correctly as before.

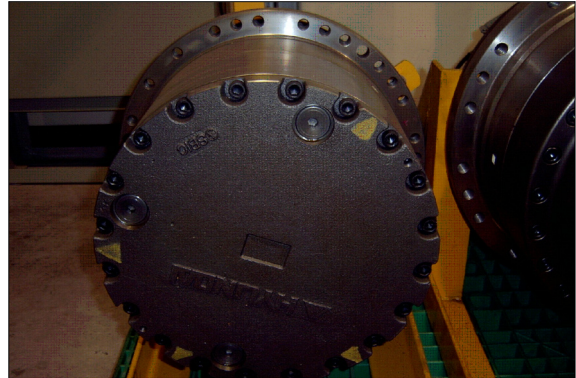

21078TM80

### 2) Setting reduction unit(or whole propelling unit) on work stand for disassembling

- (1) Remove M12 hexagon socket head bolts(95) at 3 places from cover(93) almost equally apart each other, and then install M12×155L eye bolts. Lift up the unit using them and place it on work stand with cover upward.

**▲ Take great care not to pinch your hand between parts while disassembling nor let fall parts on your foot while lifting them.**

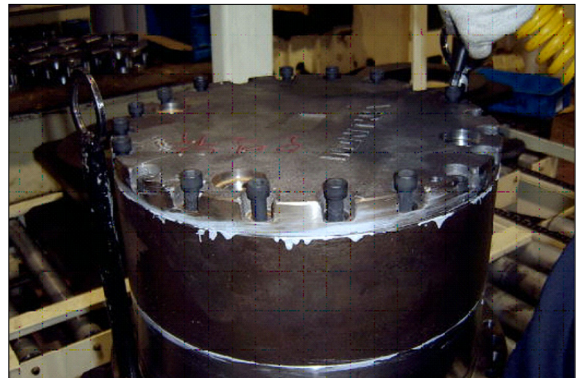

21078TM81

### 3) Removing cover

- (1) Remove the rest of M12 hexagon socket head bolts(95) that securing gear and housing. Loosen all the socket bolts and then, disassemble cover.
- (2) As the cover(93) is adhered to ring gear(88), disassemble ring gear(88) and cover(93) by lightly hammering slantwise upward using sharpened punch inserted between the cover and ring gear.

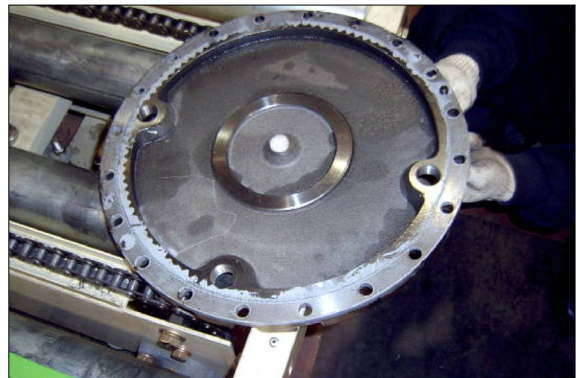

21078TM82

#### 4) Removing No.1 carrier sub assembly

- (1) Screw three M10 eye-bolt in No.1 carrier and lift up and remove No.1 carrier assy.

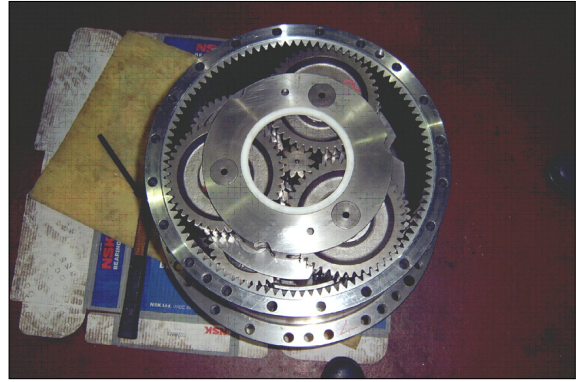

21078TM83

- (2) Remove No.1 sun gear

- ※ Be sure to maintain it vertical with the ground when disassembling No.1 sun gear.

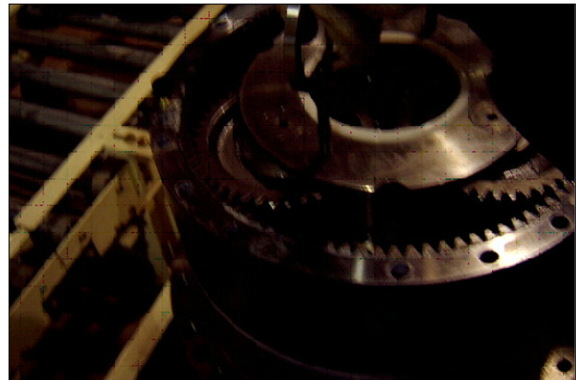

21078TM84

#### 5) Removing No.2 carrier sub assembly

- (1) Screw three M10 eye-bolt in No.2 carrier and lift up and remove No.2 carrier assy.



21078TM85

- (2) Remove No.2 sun gear

- ※ Be sure to maintain it vertical with the ground when disassembling No.2 sun gear.



21078TM86

## 6) Removing ring gear

- (1) As the ring gear(88) is adhered to housing(81), disassemble ring gear(88) and housing(81) by lightly hammering slantwise upward using sharpen punch inserted between the ring gear and housing.
  - ※ Carefully disassembling ring gear not to make scratch on it.
- (2) Screw M14 eye-bolt in ring gear and lift up and remove it.

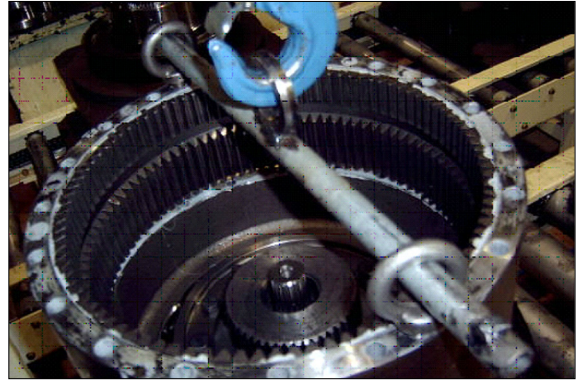

21078TM87

## 7) Removing coupling

- (1) Remove coupling.

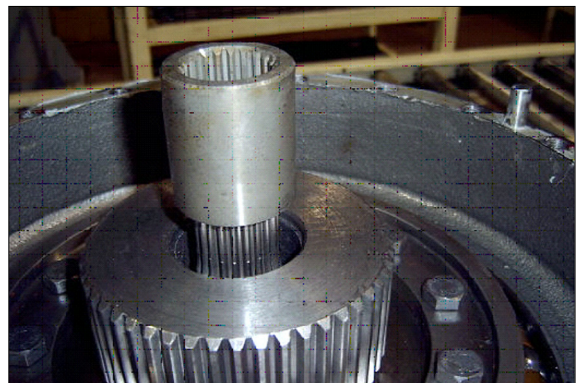

21078TM88

## 8) Removing retainer & shim

- (1) Remove M12 hexagon socket head bolts that secure retainer and motor.
- (2) Remove retainer & shim.

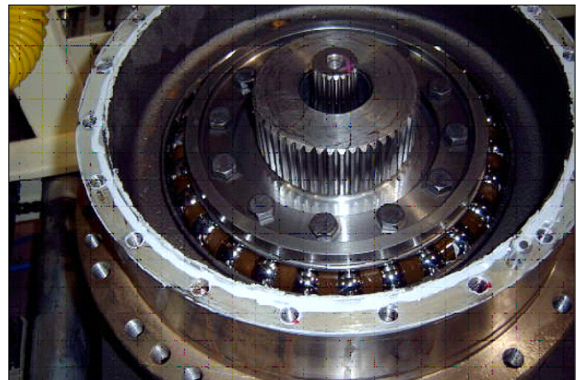

21078TM89

## 9) Removing housing sub assembly

- (1) Screw M12 eye bolt in housing and lift up housing assembly including anguler bearing and floating seal.



21078TM90

## 10) Removing floating seal

- (1) Lift up a piece of floating seal of motor side.

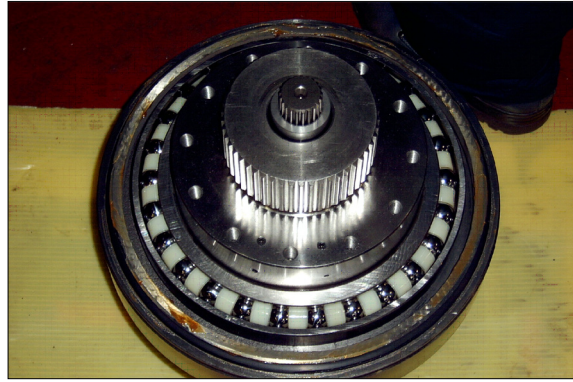

21078TM91

## 11) Disassembling housing assembly

- (1) After turning housing, lift up a piece of floating seal from housing and then remove it.
- ※ Don't disassemble anguler bearing.

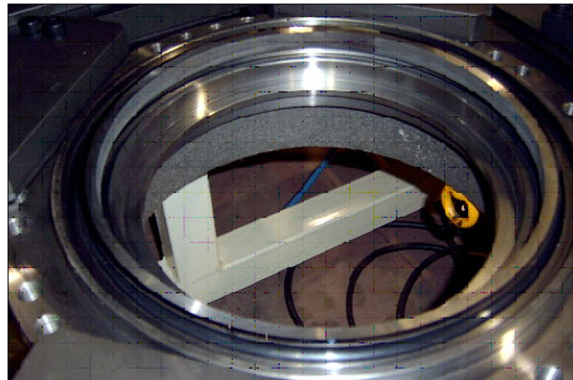

21078TM92

## 12) Disassembling No.1 carrier

- (1) Remove thrust ring(90-7) from carrier.
- (2) Knock spring pin(91-8) fully into No.1 pin (91-7).
- (3) Remove planetary, thrust washer, No.1 pin, bearing from carrier.

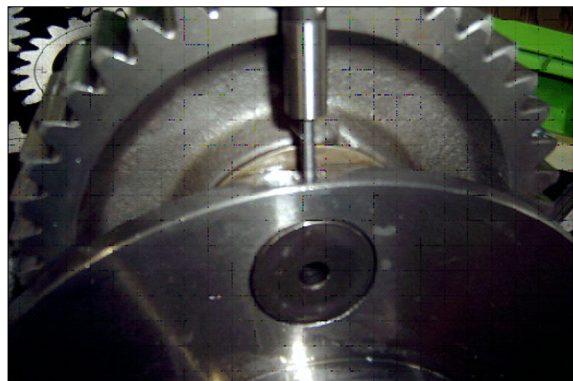

21078TM93



21078TM94





21078TM95

### 13) Disassembling No.2 carrier

- (1) Disassemble No.2 carriers, using the same method for No.1 carrier assembly.

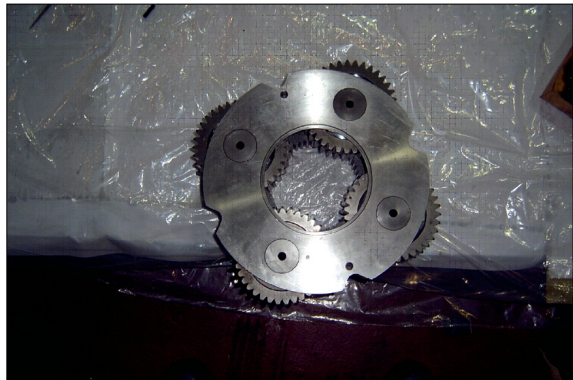

21078TM96



21078TM97

## 6.1 ASSEMBLY REDUTION GEAR

### ■ General notes

Clean every part by kerosene and dry them by air blow.

Surfaces to be applied by locktite must be decreased by solvent.

Check every part for any abnormalities.

Each hexagon socket head bolt should be used with locktite No. 262 applied on its threads.

Apply gear oil slightly on each part before assembling.

Take great care not to pinch your hand between parts or tools while assembling nor let fall parts on your foot while lifting them.

Inspection before reassembling

#### **Thrust washer**

- Check if there are seizure, abnormal wear or uneven wear.
- Check if wear is over the allowable limit.

#### **Gears**

- Check if there are pitting or seizure on the tooth surface.
- Check if there are cracks on the root of tooth by die check.

#### **Bearings**

- Rotate by hand to see if there are something unusual such as noise or uneven rotation.

#### **Floating seal**

- Check flaw or score on sliding surfaces or O-ring.

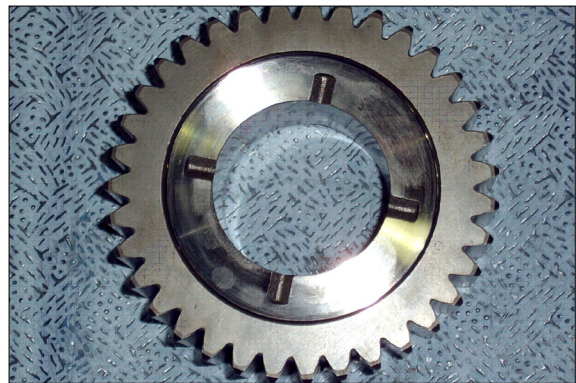

21078TM98

### 1) Assembling No.1 carrier

- (1) Put No.1 carrier(91-1) on a flat place.
- (2) Install No.1 needle bearing(91-5) into No.1 planetary gear(91-4), put 2EA of No.1 thrust washer(91-6) on both sides of bearing, and then, install it into carrier.

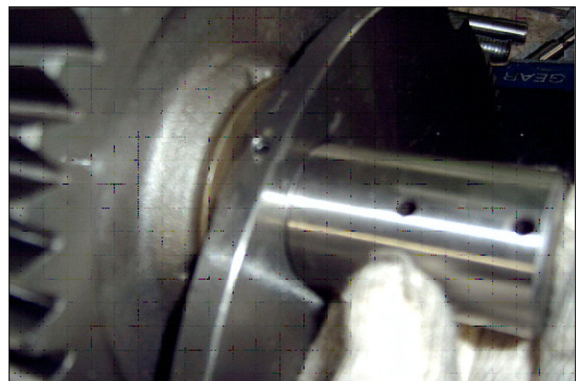

21078TM99

- (3) Install No.1 pin(91-5) into No.1 carrier where the holes for No.1 pin(91-5) are to be in line with those of No.1 carrier, and then, install spring pins into the holes.

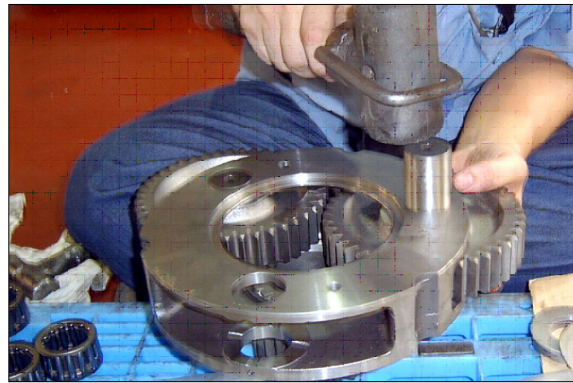

21078TM100

- (4) Caulk carrier holes as shown on the picture.  
 (5) Assembly ring thrust(90-7) into carrier.

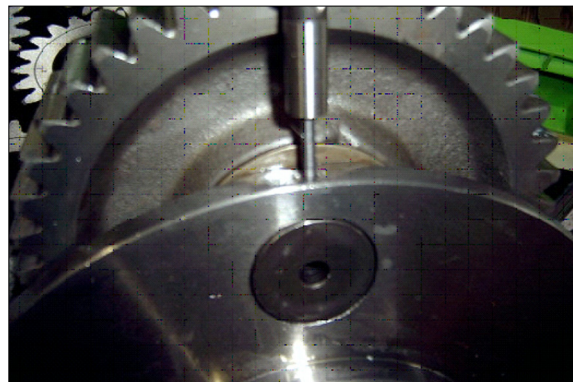

21078TM101

## 2) Assembling No.2 carrier

- (1) Put No.2 carrier(90-1) on a flat place.  
 (2) Install No.2 needle bearing(90-3) into No.2 planetary gear(90-2), put 2EA of No.2 thrust washer(90-4) on both sides of bearing, and then, install it into carrier.

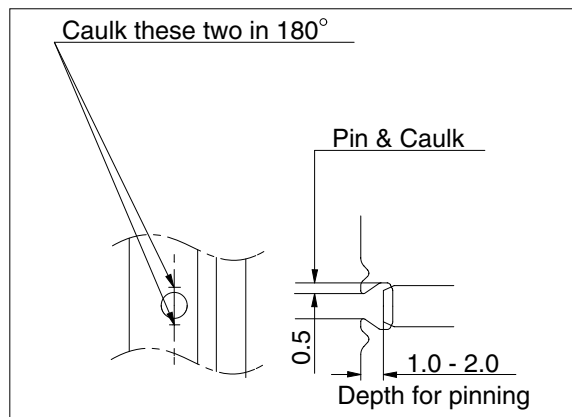

21078TM102

- (3) Install No.2 pin(90-5) into No.2 carrier where the holes for No.2 pin(90-5) are to be in line with those of No.2 carrier, and then, install spring pins into the holes.



21078TM103

- (4) Caulk carrier holes as shown on the picture.
- (5) Assembly ring thrust(90-7) into carrier.

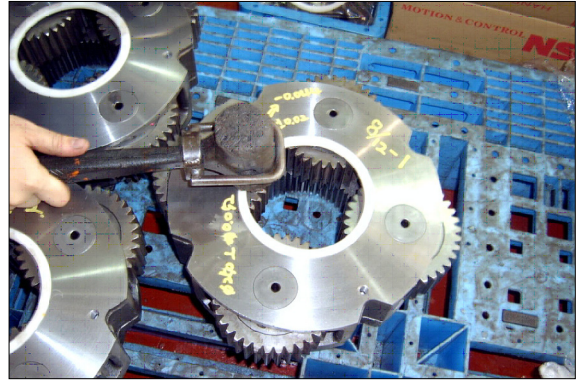

21078TM104

### 3) Assembling floating seal(83) and main bearing(82)

- (1) Assemble floating seal into motor by use of pressing jig. Grease the contact parts for floating seal which is assembled into motor.
- (2) Heat bearing at 60~70°C and then, put into the motor side.

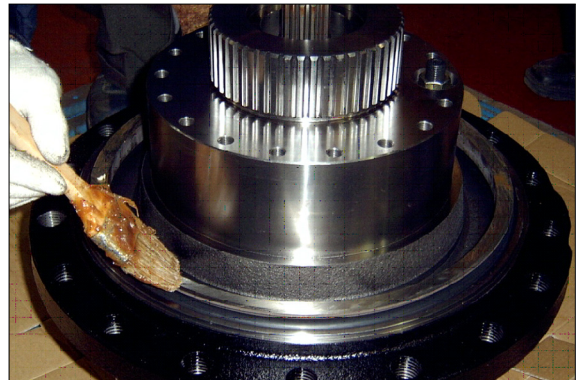

21078TM105

- ※ Be sure to maintain it vertical with the ground when assembling bearing and floating seal.



21078TM106

### 4) Assembling housing

- (1) Heat housing at 60~70°C while clearing it out and then, assemble foating seal into housing by use of pressing jig.
- ※ Be sure to maintain it vertical with the ground when assembling floating seal.

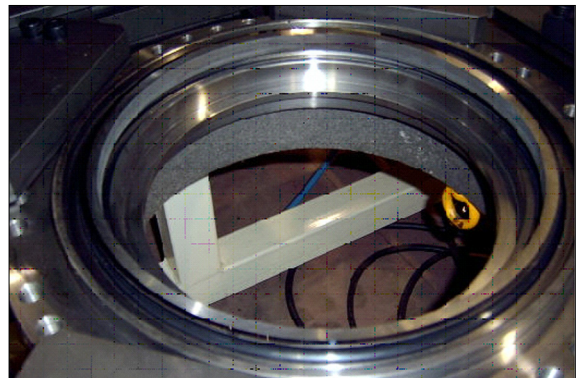

21078TM705

### 5) Installing housing assembly

- (1) Install 2EA of M12 eye-bolt into housing assembly.
  - (2) Assemble housing into motor by use of hoist and eye-bolt.
- ※ Be sure to tighten eye-bolt deep enough.

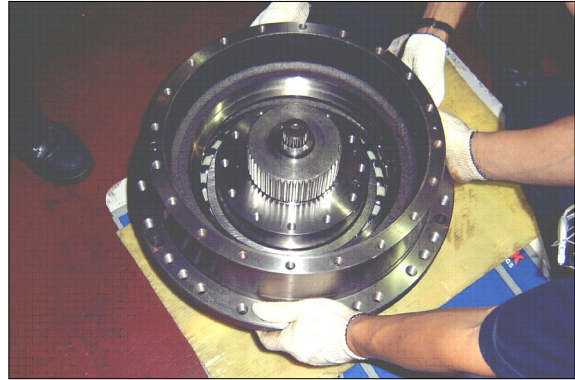

21078TM108

### 6) Installing main bearing(82)

- (1) Heat main bearing at 60~70°C and then, install.
- ※ Be sure to maintain it vertical with the ground when assembling bearing.

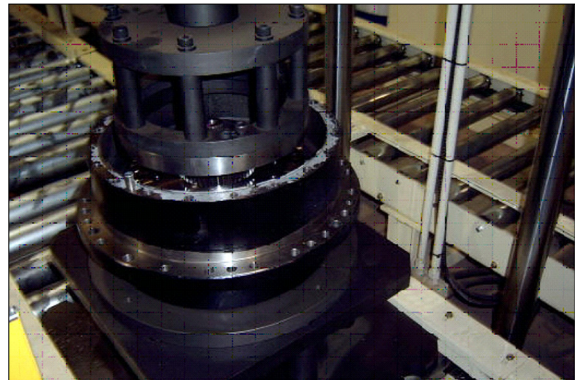

21078TM109

### 7) Installing retainer(86) and shim(85)

- (1) Measure clearance between main bearing and retainer by use of jig to decide the thickness of shim and select an appropriate shim, and then, assemble retainer.
- (2) Apply locktite(#262) on M12 hexagon head bolt, and then, bolt.

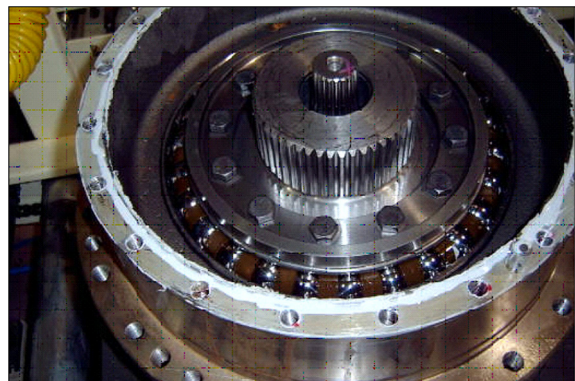

21078TM110

### 8) Installing coupling

- (1) Install coupling on spline of the motor.

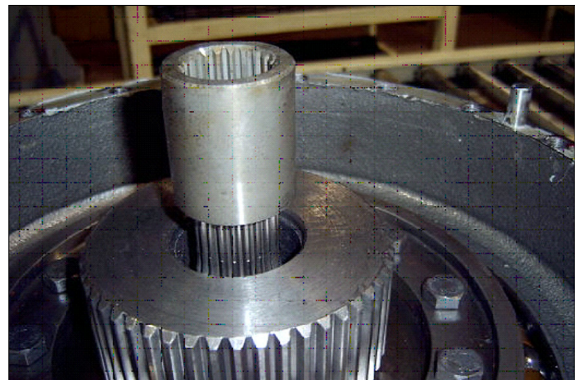

21078TM111

### 9) Installing ring gear

- (1) Apply three bone #1104(locktite #515) on housing for ring gear without gap.
- (2) Insert lock pin into housing hole.
- (3) Install M14 eye-bolt on the tap of ring gear.
- (4) Lift ring gear and then, assemble into housing in order for hole of ring gear and parallel pin of housing to be in line.
- (5) Temporarily secure 4EA of M12 hexagon socket bolt and shim with cover thickness having appropriate torque.

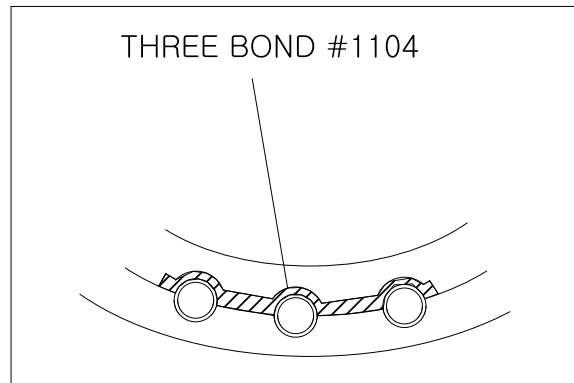

21078TM112

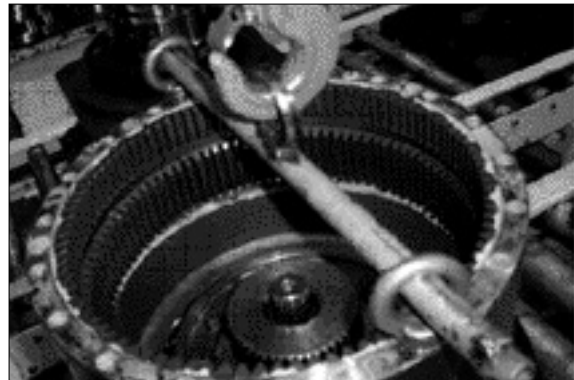

21078TM113

### 10) Installing No.2 carrier sub assembly

- (1) Install M10 eye-bolt on No.2 carrier assembly.
- (2) Lift No.2 carrier assembly and then, slowly put it down on ring gear.
- (3) Rotate planetary gear by hands and install on ring gear.



21078TM114

### 11) Installing No.2 sun gear(91-2)

- (1) Install No.2 sun gear on the spline of No.2 carrier and No.2 planetary gear, matching teeth of them.



21078TM115

- (2) Install No.2 sun gear on the spline of No.2 carrier and No.2 planetary gear, matching teeth of them.

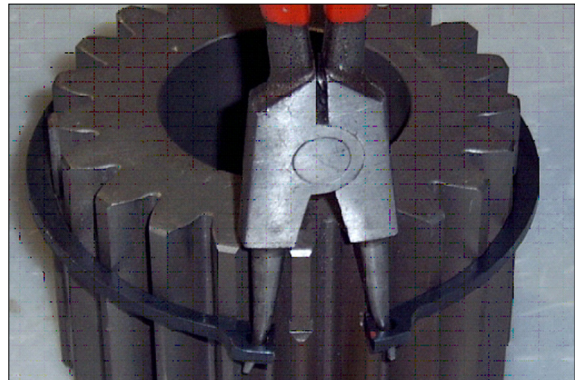

21078TM116

### 12) Installing No.1 carrier sub assembly

- (1) Install M10 eye-bolt on No.2 carrier assembly.
- (2) Lift No.1 carrier assembly and then, slowly put it down on ring gear.
- (3) Rotate planetary gear by hands and install on ring gear.

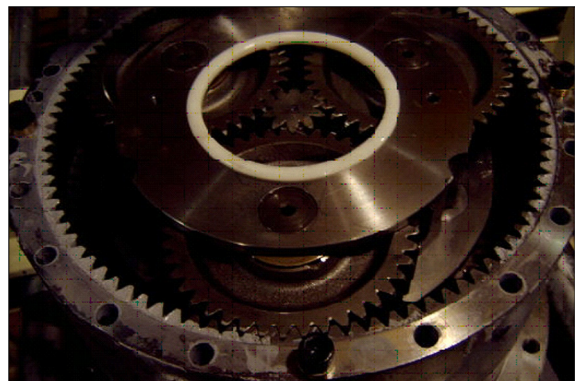

21078TM117

### 13) Installing No.1 sun gear(92)

- (1) Put down No.1 sun gear on No.1 carrier, maintaining it vertical with spline of coupling.
- (2) Install No.1 sun gear on No.1 planetary gear, matching their teeth.

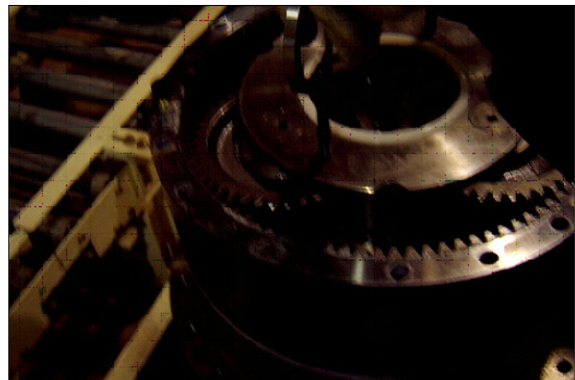

21078TM118

#### 14) Installing cover(93)

- (1) Beat pad(94) with plastic hammer, and press it into the center of cover.
- (2) Apply three bond #1104(locktite#515) on the ring gear for cover without gap.
- (3) Put cover on ring gear, apply locktite (#262) on M12 hexagon socket head bolt, and then, bolt.

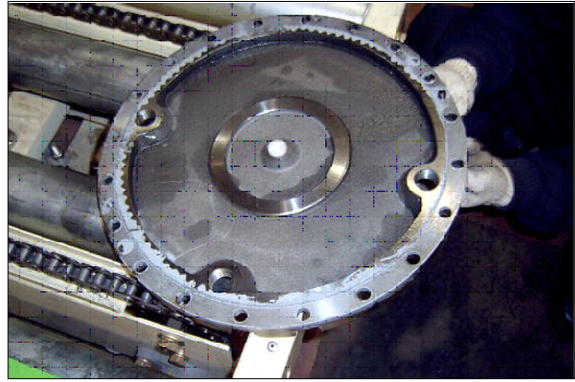

21078TM119

- (4) Fill gear oil(7.5liter) into drain port.
- (5) Apply gear oil on PF3/4 hydraulic plug(97) and then, bolt.

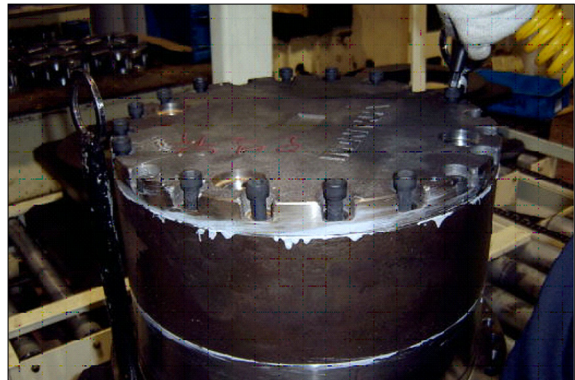

21078TM120



## GROUP 6 TRAVEL DEVICE(TM40VC)

### 1. REMOVAL AND INSTALL

#### 1) REMOVAL

- (1) Swing the work equipment 90° and lower it completely to the ground.
- (2) Operate the control levers and pedals several times to release the remaining pressure in the hydraulic piping.
- (3) Loosen the breather slowly to release the pressure inside the hydraulic tank.
- ▲ Escaping fluid under pressure can penetrate the skin causing serious injury.
- ※ When pipes and hoses are disconnected, the oil inside the piping will flow out, so catch it in oil pan.
- (4) Remove the track shoe assembly.  
For details, see **removal of track shoe assembly**.
- (5) Remove the cover.
- (6) Remove the hose.  
※ Fit blind plugs to the disconnected hoses.
- (7) Remove the bolts and the sprocket.
- (8) Sling travel device assembly(1).
- (9) Remove the mounting bolts(2), then remove the travel device assembly.  
· Weight : 305kg(670lb)

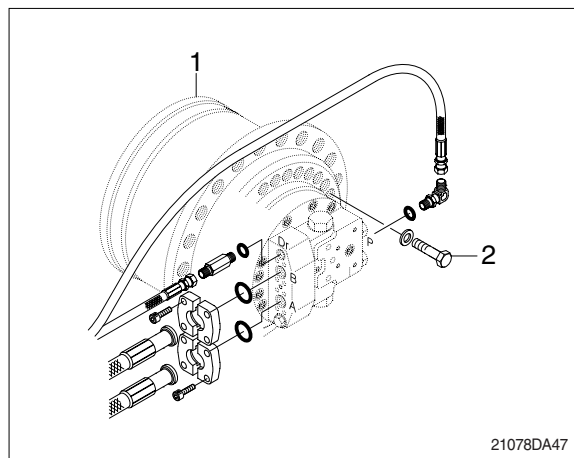

#### 2) INSTALL

- (1) Carry out installation in the reverse order to removal.
- (2) Bleed the air from the travel motor.
  - ① Remove the air vent plug.
  - ② Pour in hydraulic oil until it overflows from the port.
  - ③ Tighten plug lightly.
  - ④ Start the engine, run at low idling, and check oil come out from plug.
  - ⑤ Tighten plug fully.
- (3) Confirm the hydraulic oil level and check the hydraulic oil leak or not.

## 2) TOOLS AND TIGHTENING TORQUE

### (1) Tools

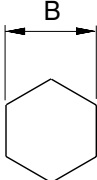
Tool name	Remark	
Allen wrench	6	
	10	
	14	
Socket for socket wrench, spanner	19	
	41	
Torque wrench	Capable of tightening with the specified torques.	
Pliers	-	
( - ) Driver	150mm	
Plastic and iron hammer	Wooden hammer allowed. Nominal 1 or so	
Steel rod approx	7 × 7 × 200mm	
Monkey wrench	-	
Oil seal inserting jig	-	
Bearing pliers	-	
Seal tape	-	
Eye bolt	M10	
Press (0.5 ton)	-	
Oil stone	-	
Bearing assembling jig	-	
Liquid packing	Loctite #577	
Screw lock	Loctite #243	

### (2) Tightening torque

Part name	Item	Size	Torque	
			kgf · m	lbf · ft
Hexagon socket plug	30	PT-1/2	10±2	72.3±14.5
Hexagon bolt	32	M12	10.4±1.6	75.2±11.6
Hexagon socket bolt	35	M18	35.5±5.5	256.8±39.8
Plug	221	PF 1/2	10±2	72.3±14.5
Plug	224	M45×1.5	51±7.5	369±54.2
Plug	226	M36×1.5	26±4	188.1±28.9
Plug	253	PF-1/4	3.0±0.5	21.7±3.6
Plug	154, 169	NPTF 1/16	1.0±0.25	7.2±1.8
Hexagon socket bolt	282	M16×2.0	25.7±4	185.9±28.9

### **3. DISASSEMBLY**

#### **1) GENERAL PRECAUTIONS**

- (1) Before disassembling the motor, check the items to be inspected and, for remedy against trouble, closely examine the nature of the trouble, so that the motor can be disassembled effectively.
- (2) To disassemble the motor, use the disassembling procedures described in section 2 and select a clean place.
- (3) Place a rubber or vinyl sheet or other such protective materials on your working bench to protect the surface of the motor to be serviced.
- (4) During disassembly, give a match mark to the mating surfaces of each part.
- (5) Arrange removed parts in order so that they will not become damaged or missing during disassembly.
- (6) Once seals have been disassembled, they should be replaced even if damage is not observed. Have replacement seals ready on hand before starting your disassembling job.

## 2) DISASSEMBLING PROCEDURE

### (1) Disassembling the brake valve section and the hydraulic motor section

- ※ When inspecting or repairing the motor, use the disassembling procedures described below.
- ※ Numbers in parentheses ( ) following the part name denote the item numbers shown in the attached assembly drawings.
- ※ Prior to disassembly, install the motor on an inversion working bench.

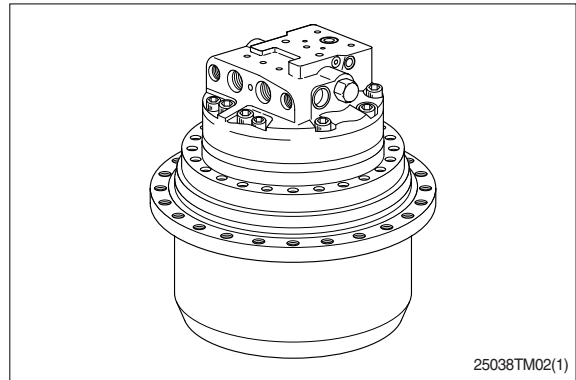

- ① Remove the relief valve from the rear flange (201).
  - Wrench : 17mm

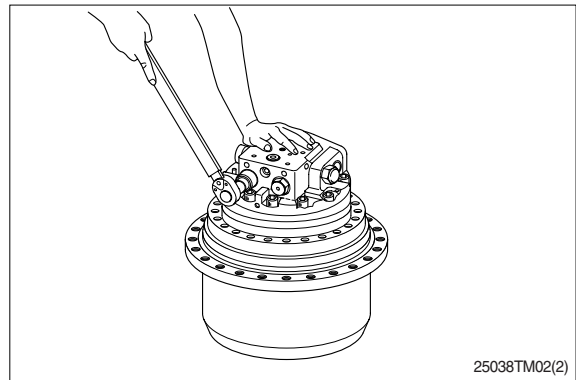

- ② Remove the nine hexagon socket head bolts(282).

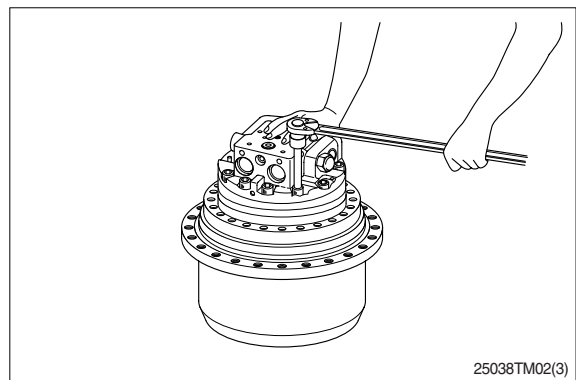

- ③ Remove the rear flange (201) from the spindle(2).

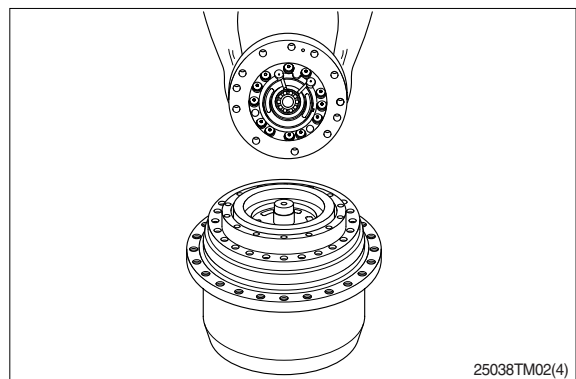

- ④ Remove the timing plate(109), the two pins(168), the nine spring(113) and the ball bearing(150) from the rear flange (201)and hydraulic motor.
- ⑤ Remove the two O-ring(29) and O-ring (39) from spindle(2).
- ※ Do not reuse the O-rings(29, 39) after removal.

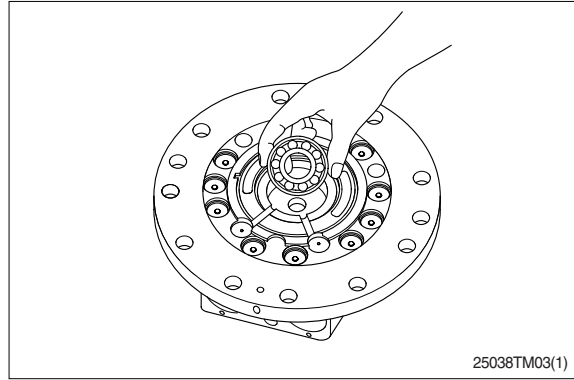

**(2) Disassembling the reduction gear/  
Hydraulic motor shafts and oil seals**

- ① Turn the motor and cover(13) over.
- ② Remove three plugs(30).
- ③ Remove twelve hexagon socket head bolts(32).

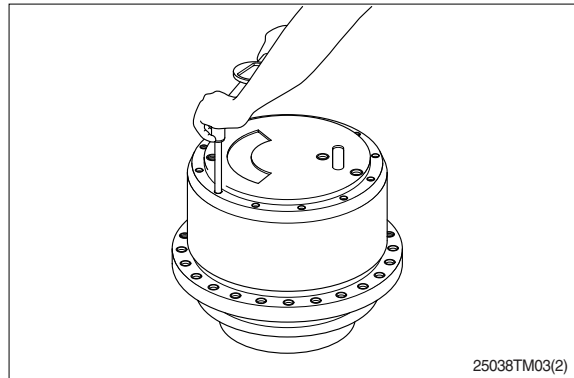

- ④ Install two eye bolt(PF 1/2) to the threads for plugs(30).
- ⑤ Fasten hook to the eye bolts then lift up cover(13).
- ※ When cover(8) do not come up easily due to friction of O-ring(30), bang cover (8) evenly using a plastic hammer.
- ⑥ Drain lubricating oil from the reduction gear.

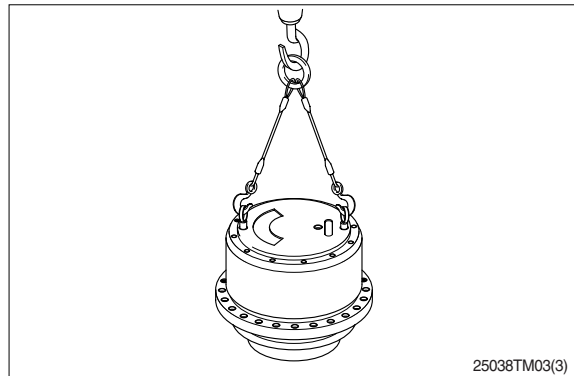

### 3) DISASSEMBLY OF BRAKE VALVE

#### (1) Disassembly of the spool

- ① Remove the two plugs(224) from the rear flange(201).

Remove the two O-ring(279) from the plug(224).

- ※ Removal of the two plugs(224) from the rear flange(201) can better be done by loosening the former beforehand with the latter connected to the spindle(2).

- ※ Do not reuse the O-ring(279) after removal.

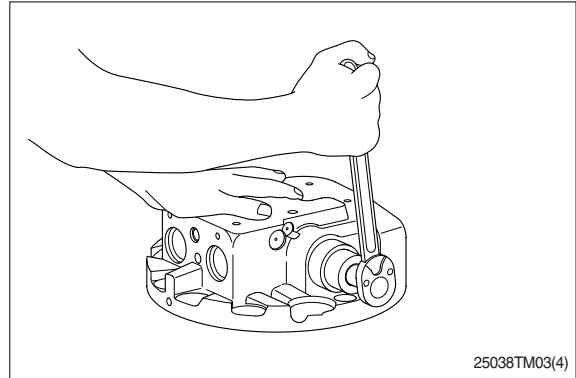

- ② Remove the two springs(228), the two stoppers, and the spool(223) from the rear flange(201).

- ※ Be careful not to damage the outer surface of the spool(223) and the sliding surface of the rear flange(201).

- ※ Since the rear flange(201) and the spool(223) are of the selective fitting type, replace them together as a kit even if only one of the two parts is damaged.

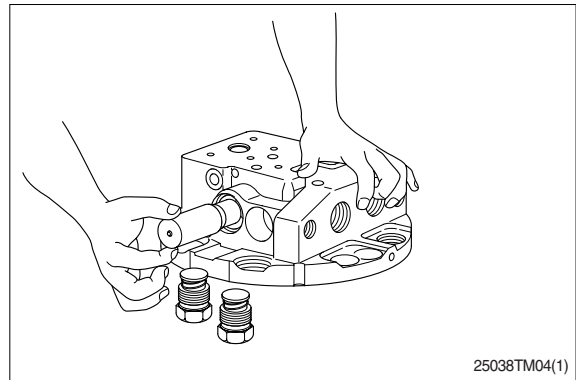

#### (2) Disassembly of the check valves

- ① Remove the two plugs(226) from the rear flange(201).

- ※ Removal of the two plug(226) from the rear flange(201) can better be done by loosening the former beforehand with the latter remaining connected to the spindle(2).

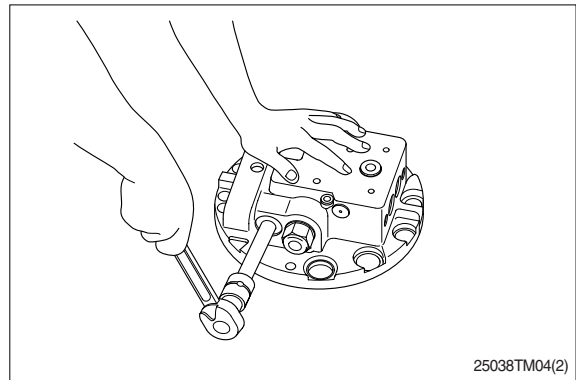

- ② Remove the two springs(230) and the two valves(227) from the rear flange (201).
- ※ Be careful not to damage the seat sections of the valves(227) or rear flange (201).
- ③ Remove the O-ring(234) from the plug (226).
- ※ Do not reuse the O-ring(234) after removal.

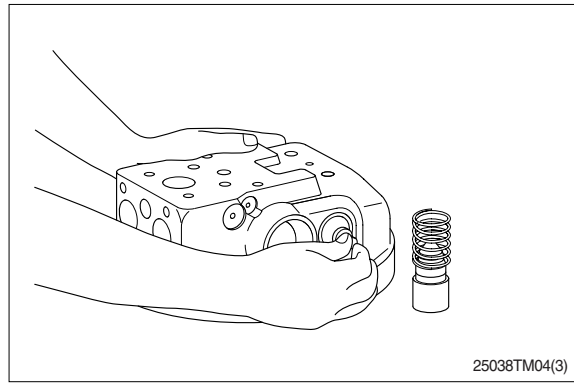

### (3) Disassembly of the two valve(263)

- ① Remove the plug(264) and two valves(263) and the spring(266) from the rear flange(201).

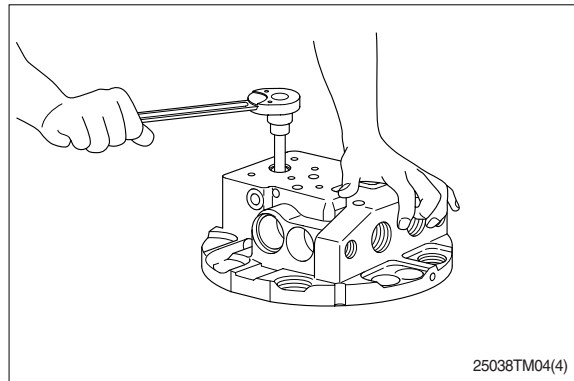

### (4) Disassembly of the reducing valve

- ① Press and hold down the valve seat(218) using a steel bar, and in that state, as shown in the figure, press the notch in the ring(222) using a sharp-pointed steel bar.

This deforms the ring(222), disengaging it from the ring groove in the rear flange(201).

The ring(222) can now be removed from the rear flange(201).

- ※ After disassembly, do not reuse ring (272).
- ※ Removing the ring(272) damages the hole section.
- ※ Repair the hole section after disassembly.
- ※ Remove the ring(222) only when the valve(219) is to be replaced.

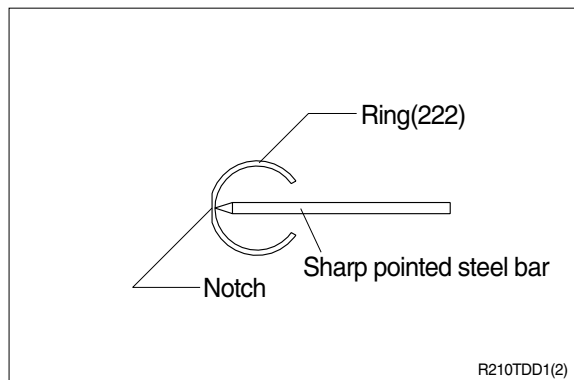
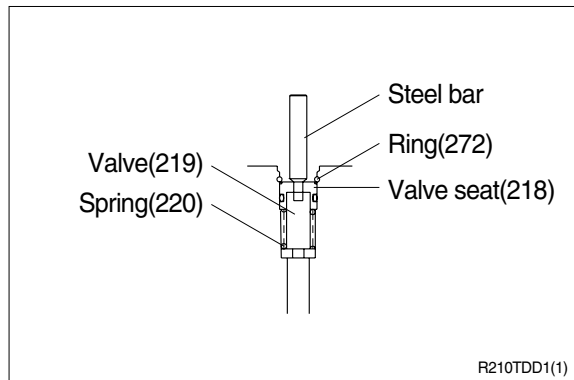

#### 4) DISASSEMBLY OF HYDRAULIC MOTOR

##### (1) Disassembly of the parking brake

① Remove the piston(112) by injecting compressed air from the parking brake access hole in the spindle(2).

※ Take care that abrupt injection of compressed air(3~5kgf/cm<sup>2</sup>) may cause the piston(112) to pop out.

To ensure your safety, apply a protective cover to the piston.

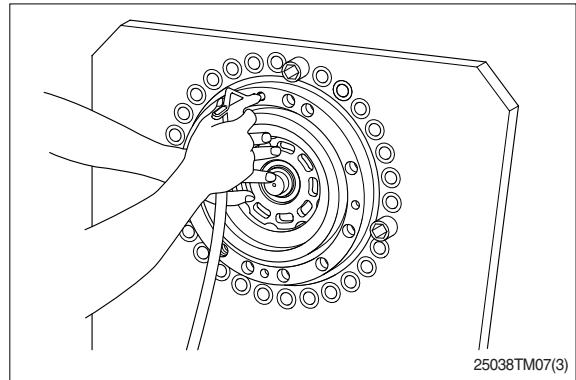

② Remove the two O-rings(139, 178) from the piston(112).

※ Do not reuse O-rings(139, 178) after removal.

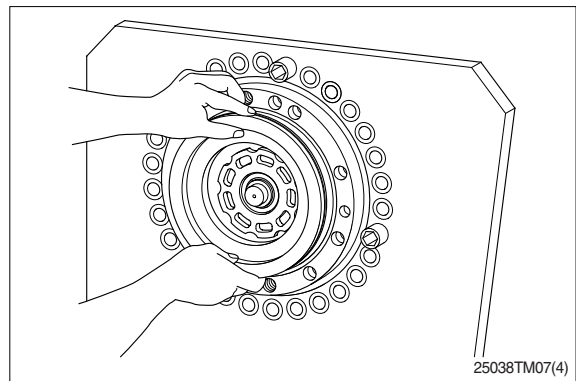

##### (2) Disassembly of the internal parts of the motor

① Lay the motor body on the side.

② Drain out the oil from the motor.

③ Hold the cylinder block(104) with both hands, and remove it from the spindle(2).

※ Place an oil receptacle under the motor to receive the oil flowing out as the motor is being laid on the side.

※ Before removal, hold the cylinder block(104) with both hands and turn it two or three times in a clockwise and a counterclockwise direction alternately to detach the shoe(106) from the swash plate(103).

Be careful that if an attempt is made to remove the cylinder block(104) without detaching the shoe(106) from the swash plate(103), then the piston, shoe, and other parts that are connected to the cylinder block may come loose and fall into the spindle.

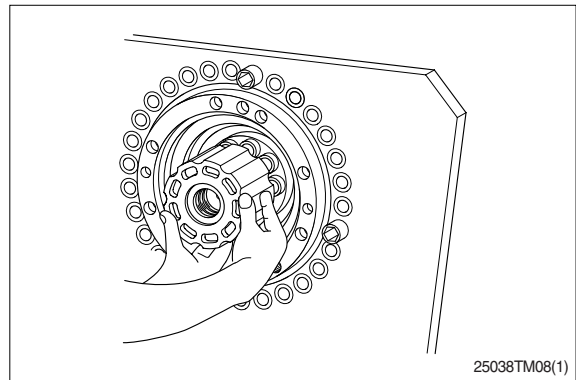



- ④ Remove the three friction plates(115) and four mating plates(116) from cylinder block(104).

Separate the piston assembly(105, 106),

- ⑤ retainer plate(107), thrust ball(108), and six rollers(151) from cylinder block(104).

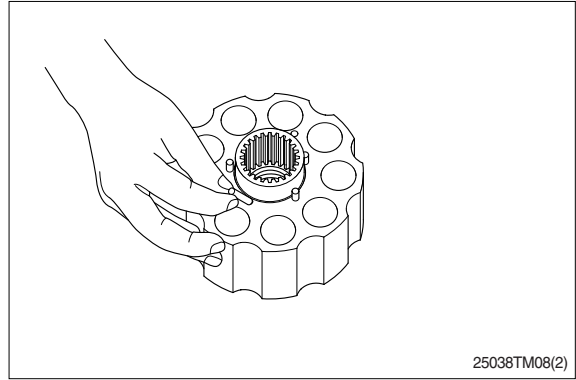

- ⑥ Remove the swash plate(103) from the spindle (2).

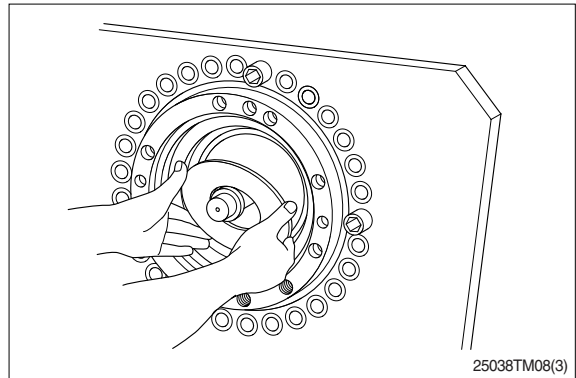

- ⑦ Remove the shaft(102) from the spindle (2). At this time, ball bearing(149) is also taken out together with shaft(102).

※ Oil seal(132) cannot be taken out.

※ Lightly shaft(102) end on the reduction gear side with a plastic hammer to make the removal easier.

Take notice when removing the shaft (102) rap strongly and swiftly, the shaft will come quickly free from the spindle.

- ⑧ Remove the two pivots(167) and the parallel pins (168) from spindle(2).

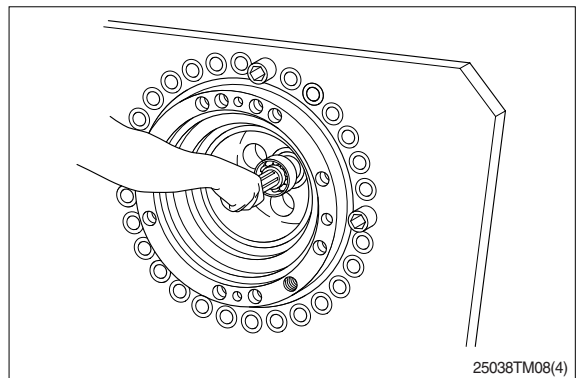

- ⑨ Remove the speed selector piston assembly by compressed air(3~5kgf/cm<sup>2</sup>) through the passage for the piston assembly in spindle(2).
- ※ Piston(161) and shoe(162) are included in the piston assembly and are not supplied one by one, therefore, the piston assembly should be replaced.
- ※ Abrupt compressed air causes the piston assembly to spring out which dangerous. The piston assembly can be taken out safely by putting a protective cover or the lie on it.

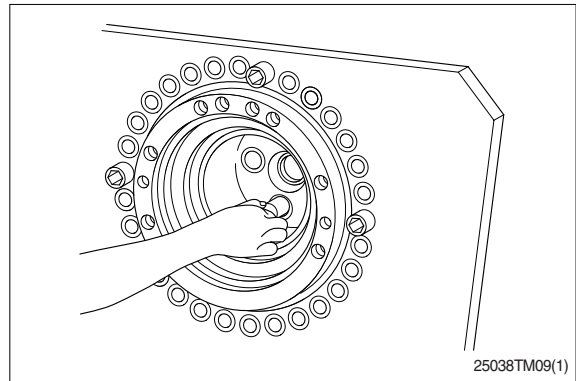

### (3) Disassembly of the cylinder block

- ① Place the cylinder block on the work bench and take out snap ring(145) with the snap ring pliers while pressing the retainer against washer(110).
- ※ Before compressing spring(114), make sure that cylinder block(104), retainer and press arbor are in good alignment: This is for galling or denting cylinder block(104).
- ※ Put a vinyl cover on the sliding surface of cylinder block(104) for protection.
- ② Slacking the press force slowly, until free of the spring force.
- ※ Do not remove spring(114) if it not to be replaced.
- ※ When disassembling there is a possibility that the spring may be injured. Slacking very slowly in order to prevent injury to the spring.

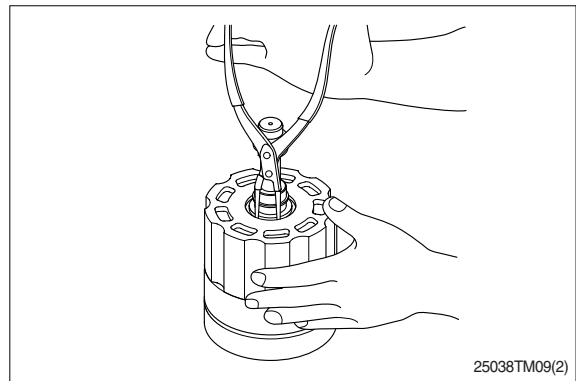

- ③ Remove the snap ring(145), washer (110), spring(114) and washer(110) from cylinder block(104).
- ※ Remove the spring(114) only if it is to be replaced.

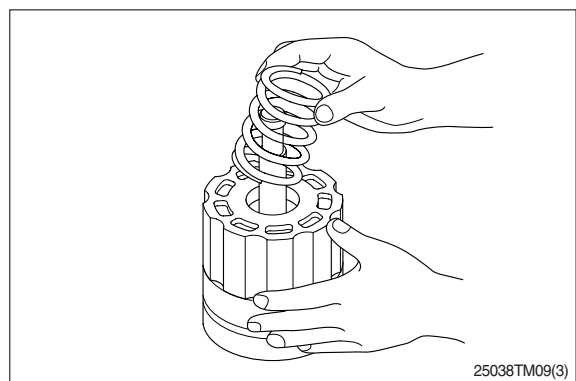

## 5) DISASSEMBLY OF REDUCTION GEAR

### (1) Disassembly of ring gear A(4)

- ① Before removing ring gear A, give an alignment match mark to both the ring gear and hub(1).
- ② Remove the ring gear A(4) using a crowbar or any other suitable tool.
  - ※ After ring gear A(4) has been removed, remove any adhesive residue from the mating surfaces of the ring gear and the hub.
- ③ Remove the ten dowel pins(27) from the hub(1).

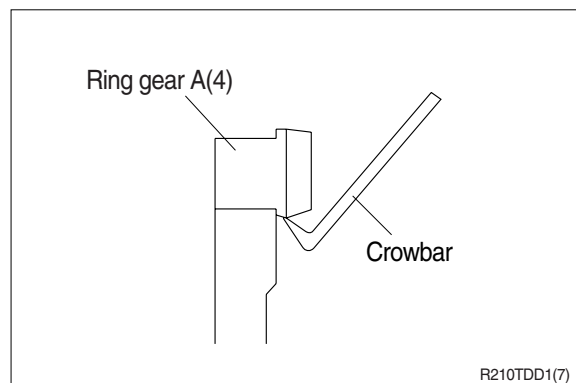
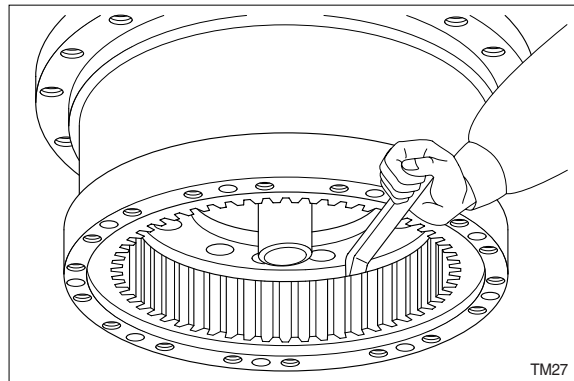

### (2) Disassembly of the hub(1), ring gear B(5), and the coupling gear(8)

- ① Remove the ten hexagon socket head bolts(35).
  - ※ Since the hexagon socket head bolts(35) have their threaded sections coated with an adhesive, a loosening torque larger than the tightening one is needed to remove the bolts.
  - ※ Tightening torque :  $35.5 \pm 5.5 \text{ kgf} \cdot \text{m}$   
( $256.8 \pm 39.8 \text{ lbf} \cdot \text{ft}$ )
  - ※ Be extra careful during removal not to let the threaded sections of the hexagonal socket head bolts(35) seize.
- ② Before removing the coupling gear(8) from the spindle(2), mark the mating surfaces of the coupling gear(8) and the spindle(2) using a paint marker.

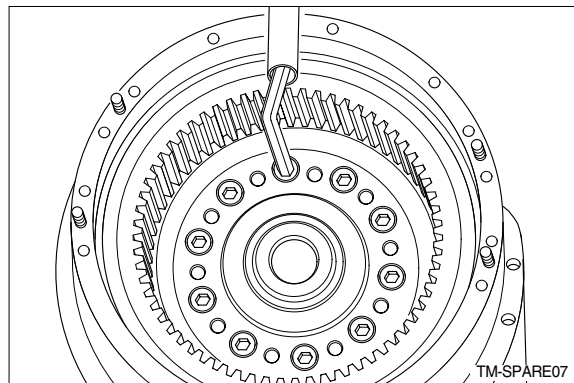

- ② Mount ring bolts in the M12 tapped holes of the hub(1), and then lift the hub(1) using lifter and separate the hub(1) and the spindle(2).

This also disconnects the two ball bearings(24), seal ring(23), O-ring(40), coupling gear(8), ring gear B(5), ring(15), and the distance piece(12).

- ※ Proceed as follows if disassembly is not possible with the method mentioned above :

- Rotate the motor through 180 degrees to let the spindle side of the motor face upward.
- As shown in the photo, lightly tap the edge of the hub(1) equally with an aluminum rod and a hammer until the hub(1) has become disconnected from the spindle(2).

This will also disconnect the following parts :

Two ball bearing(24), seal ring(23), O-ring(40), coupling gear(8), ring gear B(5), ring(15), distance piece(12).

- ※ Lay a rubber mat under the working bench to prevent damage to hub(1) and other parts due to possible fall from the working bench.

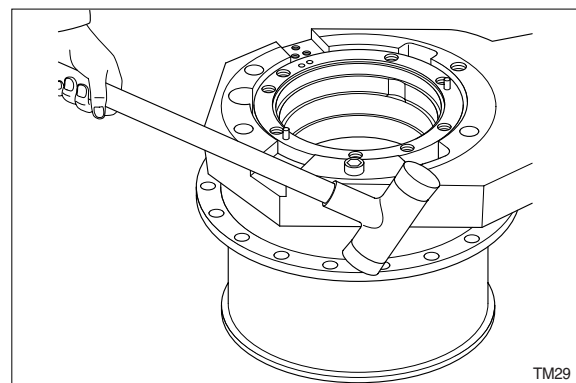
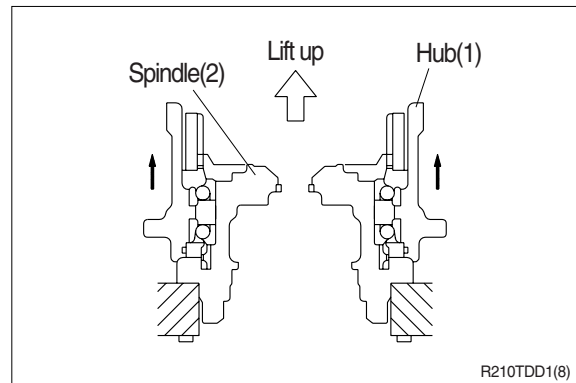

**(3) Disassembly of the inside of the spindle(2)**

- ① Remove the O-ring(29) from the spindle(2).
- ② Rotate the spindle(2) through 180 degrees.
- ③ Remove the oil seal(132) from the spindle(2).

(To remove the oil seal, set a (-) screwdriver at the cylindrical edge of the oil seal and lightly tap with a hammer.)

- ※ Do not reuse the O-ring(29) after removal.
- ※ Remove the oil seal(132) only if it is to be replaced.  
Do not reuse the oil seal(132) once it has been removed.

- ④ Remove the floating seal(26) from the spindle(2).

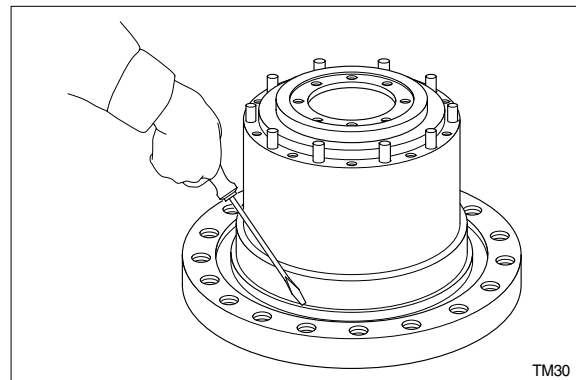
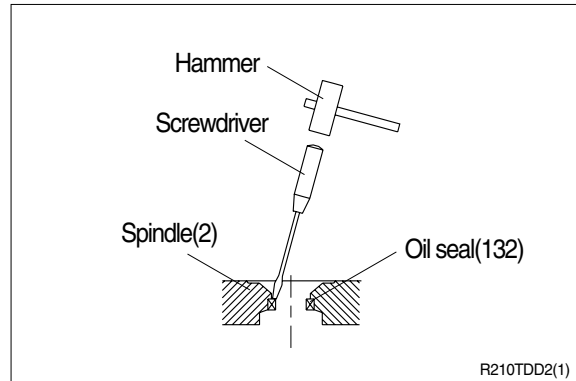

#### (4) Disassembly of the inside of the hub(1)

- ① Place the hub(1) on the working bench so that the cover side of the hub faces upward.

- ② Remove one of the two ball bearings(24) from the hub(1) as shown in the figure. This also lets the seal ring(23) come loose.

※ In principle, the ball bearings(24) should not be removed from the hub(1) since the former is shrinkage-fitted into the latter.

※ Do not reuse the ball bearings(24) after removal.

- ③ Place the hub(1) on the working bench so that the hub end facing the spindle points upward.

- ④ Remove the other ball bearing(24) from the hub(1) as shown in the figure.

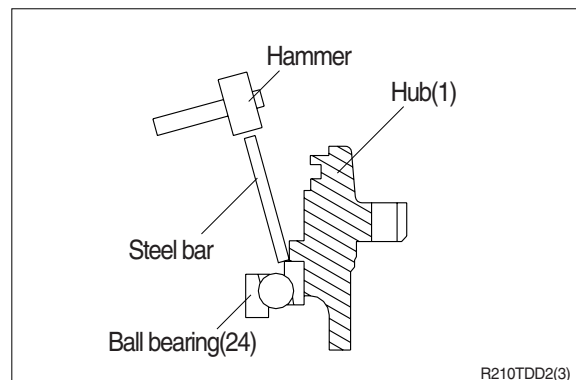
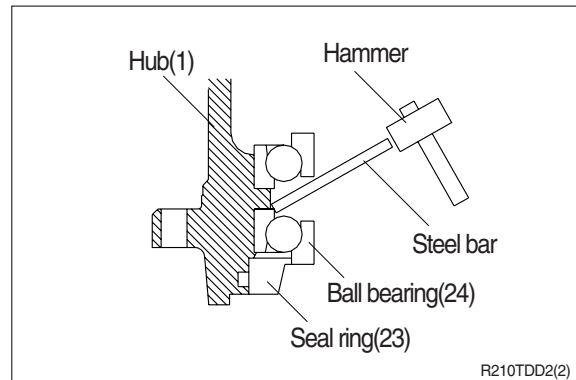

- ⑤ Remove the O-ring(40) from the hub(1).

※ Do not reuse the O-ring(40) after removal.

### (5) Disassembly of the coupling gear(8)

- ① Remove the ring(15) from ring gear B(5).
- ※ Do not reuse the ring(15) after removal.

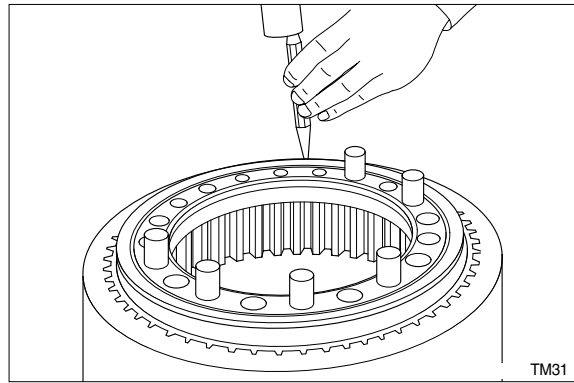

- ② Remove the coupling gear(8) from ring gear B(5).
- ※ Except for their replacement, do not disassemble the coupling gear(8) or ring gear B(5).

### (6) Disassembly of the carrier assembly

- ① Do not disassemble the carrier assembly any further.  
If a component of the carrier assembly is irrecoverably damaged, replace the entire carrier assembly with a new one.
- ※ Components of the carrier assembly
  - Carrier(3)
  - Cluster gear(6)
  - Shaft(9)
  - Thrust collar(14)
  - Needle bearing(25)
  - Dowel pin(34)

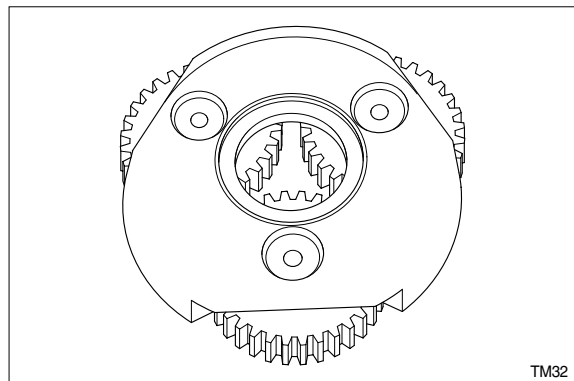

## **4. ASSEMBLY**

### **1) GENERAL PRECAUTIONS**

- (1) Reassemble in a work area that is clean and free from dust and grit.
- (2) Handle parts with bare hands to keep them free of liny contaminats.
- (3) Repair or replace the damaged parts.  
Each parts must be free of burrs its corners.
- (4) Do not reuse O-rings, oil seal and floating seal that were removed in disassembly.  
Provide the new parts.
- (5) Wash all parts throughly in a suitable solvent.  
Dry throughly with compressed air.  
Do not use the cloths.
- (6) When reassembling oil motor components of motor, be sure to coat the sliding parts of the motor and valve with fresh hydraulic oil. (NAS class 9 or above)
- (7) Use a torque wrench to tighten bolts and plugs, to the torque specified as follows.



## 2) ASSEMBLY OF BRAKE VALVE

### (1) Assembly of the check valve

- ① Fit the O-ring(234) on the plug(226).
  - ② Insert the spring(230) and the valve(227) into the plug(226), and then grease the spring(230) and the valve(227) and hand-lock the former.
  - ③ Insert the plug(226) in conjunction with the spring(230) and the valve(227) into the rear flange(201), and tighten the plug to the required torque.
- ※ Apply grease to the O-ring(234).
  - ※ Tighten the plug(226) to a torque of  $26 \pm 4 \text{kgf} \cdot \text{m}$  ( $188 \pm 29 \text{lb} \cdot \text{ft}$ ).

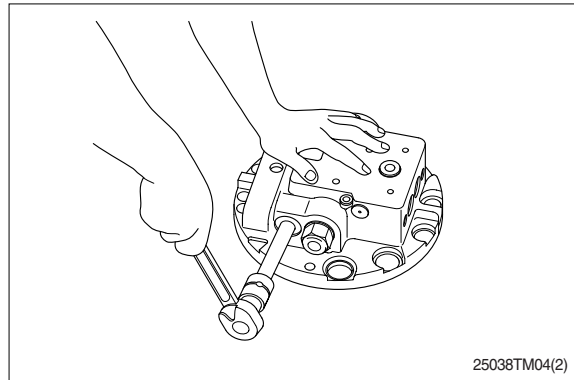

### (2) Assembly of the spool

- ① Insert the spool(223) into the rear flange (201).
- ※ Apply a working fluid to the spool(223) and insert it into the rear flange(201).
  - ※ The spool must be remounted with its axial center accurately in line with the hole center of the rear flange. This prevents the inner surface of the rear flange and the outer surface of the spool from damage due to their contact.
- ② Attach the O-ring(279) to the plug(224).
- ※ Apply grease to O-ring(279).

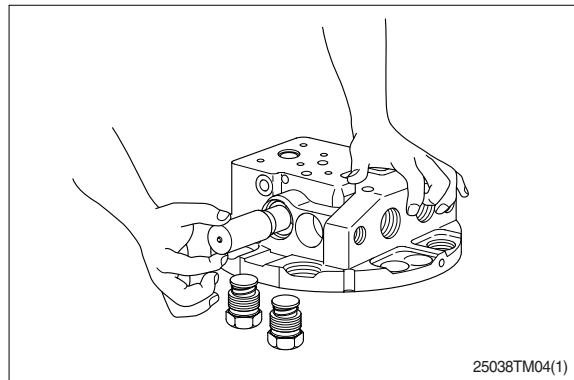

- ③ Install stopper(225) and the spring(228) into both plugs(224) and tighten the plugs(224) into the rear flange(301) at the required torque.
- ※ Required torque :  $51 \pm 7.5 \text{kgf} \cdot \text{m}$   
( $369 \pm 54.2 \text{lb} \cdot \text{ft}$ )
  - ※ Even if either the rear flange(201) or the spool(223) is to be replaced, their entire assembly(kit) must be replaced.

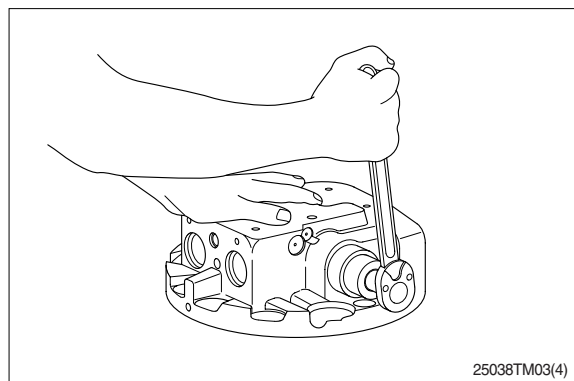

### (3) Assembly of the two-speed control valve

① Insert the plug(264) and the two valves(263) and the spring(266) from the rear flange(201).

※ Tightening torque :  $3 \pm 0.5 \text{ kgf} \cdot \text{m}$   
( $21.7 \pm 3.6 \text{ lbf} \cdot \text{ft}$ )

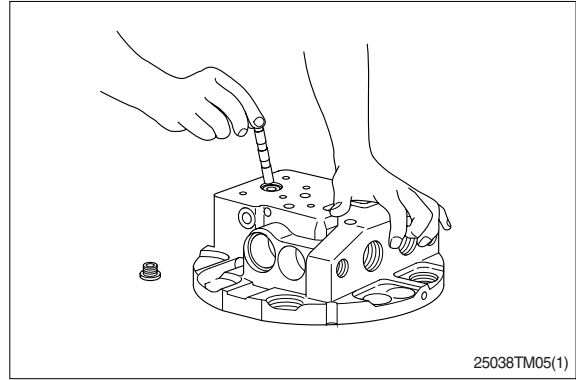

### (3) Assembly of the valve(142)

① Assemble the reducing valve assembly, the valve seat(272), and the spring(275) into the rear flange(201).

※ Press and hold down the valve seat(272) using a steel bar, and in that state, mount the ring(276) in the ring groove of the rear flange(201).

The ring(276) will remain deformed while inside the rear flange(201).

Before inserting the ring(276) into the ring groove of the rear flange(201), therefore, both ends of the ring must be extended using snap-ring pliers.

The ring(276) must be a new one.

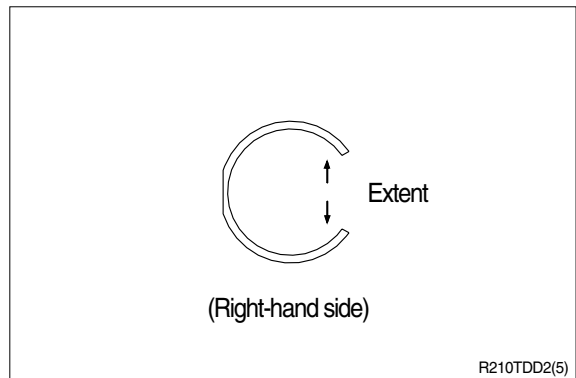
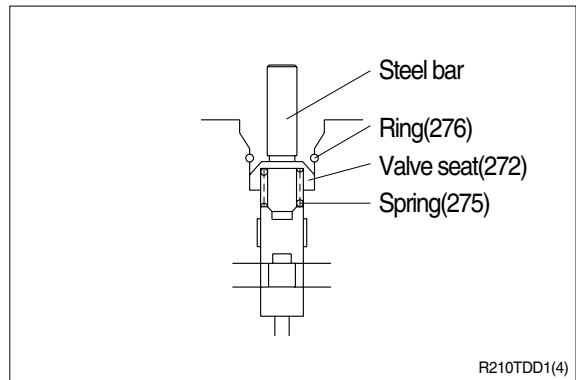

### 3) ASSEMBLY OF REDUCTION GEAR AND HYDRAULIC MOTOR

- ※ Before reassembling the reduction gear and the hydraulic motor following completion of parts replacement, one of the following two operations must be carried out:
  - Selecting a distance piece(12) of the appropriate thickness.
  - Selecting a thrust bearing(20) of the appropriate thickness.
- ※ Reassembling must be down only after clearance adjustment of these parts.
- ※ Prior to the start of reassembling, check for parts that require replacement.

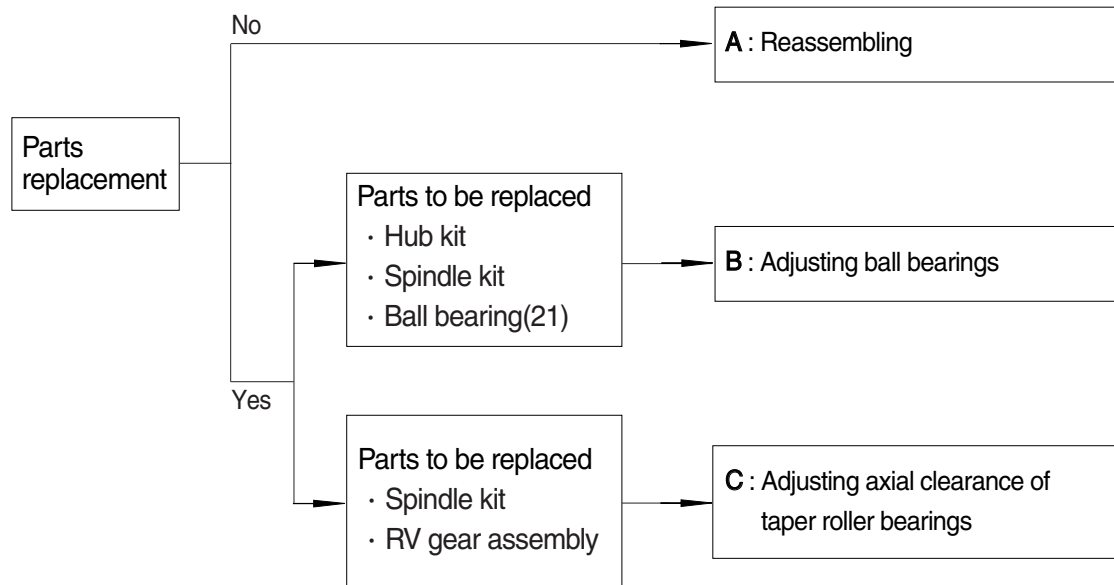

- ※ When the parts listed above are to be replaced, use correctly preadjusted parts as the replacement ones.
- ※ Reassembling with nonadjusted parts may cause motor malfunctions, resulting in early damage.

## A : REASSEMBLING

### (1) Assembly of the hub section

- ① Mount the hub(1) on a working bench so that the mounting side of the cover(13) faces upward.
- ② Insert the ball bearing(24) into the hub(1) using a force-fitting jig.
  - ※ Heat the hub(1) to a temperature of  $90 \pm 5^{\circ}\text{C}$ .
  - ※ Shrinkage-fit the ball bearing(24).
  - ※ If a force-fitting jig is not available, insert the ball bearing(24) into the hub(1) and then hammer the former.
- ③ Rotate the hub(1) through 180 degrees to make the mounting side of the spindle(2) face upward.
- ④ Insert the ball bearing(24) into the hub(1) using a force-fitting jig.
  - ※ Shrinkage-fit the ball bearing(24).
- ⑤ Assemble the O-ring(40) into the hub(1).
  - ※ Apply a thin coat of grease to the O-ring(40).
- ⑥ Assemble the seal ring(23) into the hub(1).

The seal ring can better be assembled into the hub by tapping the edge of the seal ring lightly with a plastic hammer.

  - ※ When assembling the seal ring(23) into the hub(1).
  - ※ Be extra careful not to damage the O-ring(40).

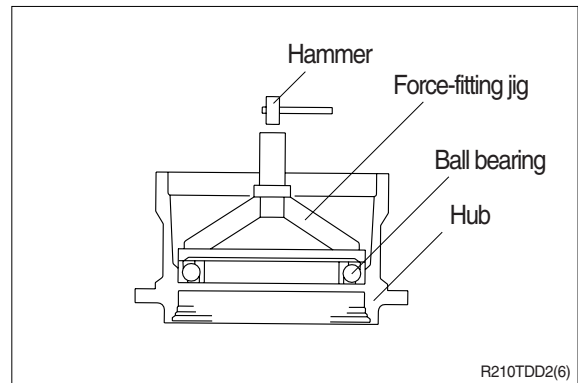

## (2) Assembly of the spindle(2) section

- ① Mount the two floating seals(26) in the spindle(2).
- ※ Apply a thin coat of grease to the O-ring in the floating seal(26).
- ※ Be extra careful to ensure that dust does not stick to the seal surface.

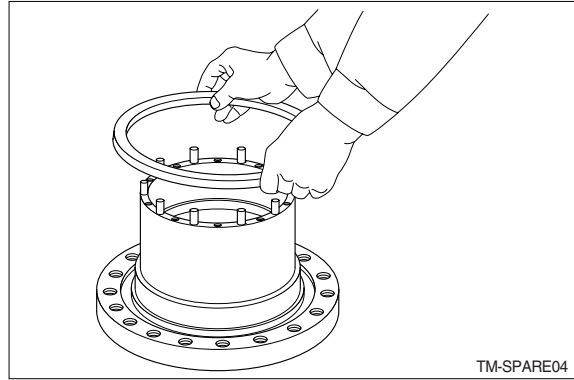

## (3) Assembly of the hub(1) and the spindle(2)

- ① Mount the spindle(2) on a working bench so that the cover side of the spindle faces upward.
- ② Fit eye-bolts to the hub(1), and then lift it with a crane and gently insert it into the spindle(2).
- ※ If the hub(1) or the spindle(2) does not snugly fit because of the presence of the ball bearing(24) evenly tap the top of the hub(1) with a plastic hammer during fitting.

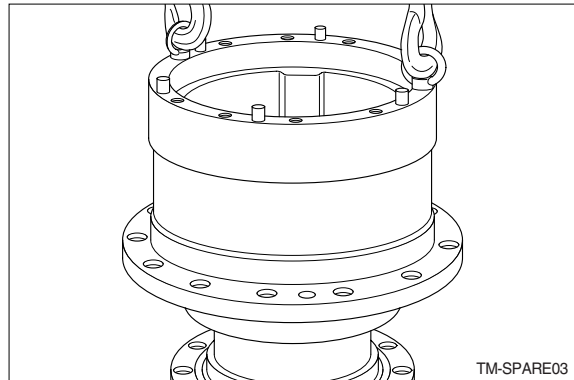

## (4) Assembly of the coupling gear(8) and ring gear B(5)

- ① Mount the coupling gear(8) in ring gear B(5).
- ② Fit the ring(15) into the ring groove of ring gear B(5).
- ※ Do not reuse the ring(15) after removal. Use a new one during reassembling.

### (5) Assembly of the coupling gear(8)

- ① Attach a distance piece(12) to the coupling gear(8) using grease.
- ※ During attachment, apply a thin coat of grease to the mounting surface of the coupling gear(8) to prevent possible fall of the distance piece(12).

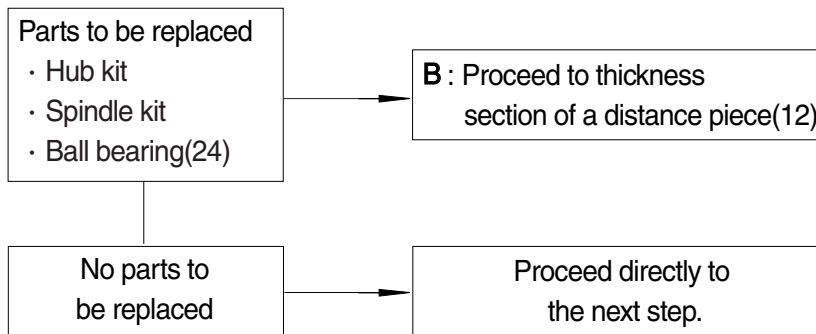

- ② Mount the coupling gear(8) (fitted with ring gear B(5)) on a coupling gear lifter, and then lift it with the crane and mount it in the spindle.
- ③ Match the match marks on the coupling gear(8) and the spindle(2).
- ④ Insert the ten pins(17), and caulk the pin hole edges of the coupling gear(8).
- ※ Do not reuse the pins(17) after removal. Use new ones during reassembling.

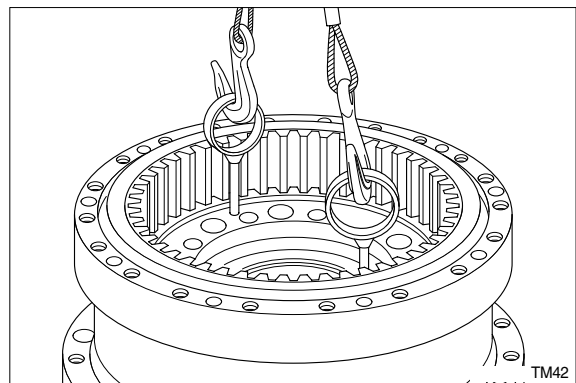

- ⑤ Tighten the ten hexagonal socket bolts(35) to the required torque using a torqu wrench.
- ※ Tightening torque :  $35.5 \pm 5.5 \text{ kgf} \cdot \text{m}$   
( $256.8 \pm 39.8 \text{ lbf} \cdot \text{ft}$ )
- ※ Apply an adhesive to the threaded section of the spindle(2) and the pin holes after degreasing both.
- ※ After completely degreasing the hexagonal socket bolts(35), apply molycoat to the bottom of each such bolt neck.
- ⑥ Rotate the motor through 180 degrees to make the spindle side face upward.

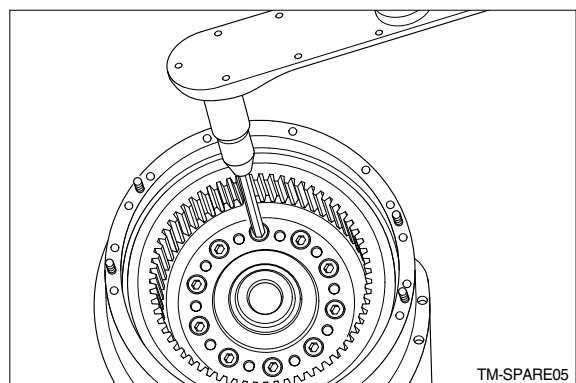

### (6) Assembly of the oil seal(132)

- ① Fit the oil seal(132) into the oil seal mounting hole of the spindle(2).
- ※ Apply white petrolatum or lithium grease to the lip section of the oil seal(132).
  - ※ Use a new oil seal during reassembling.

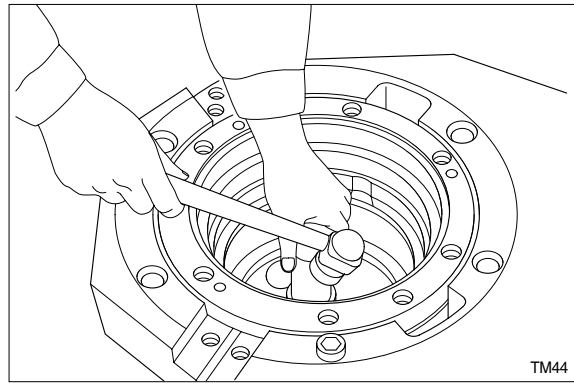

### (7) Assembly of the ball bearing(149)

- ① Shrinkage-fit the ball bearing(149) onto the shaft(102).
- ※ If the ball bearing(149) has been removed from the shaft(102) during disassembling, replace the former with a new one and then shrinkage-fit it onto the shaft(102).
  - ※ Shrinkage-fitting temperature :  $100 \pm 10^{\circ}\text{C}$ .

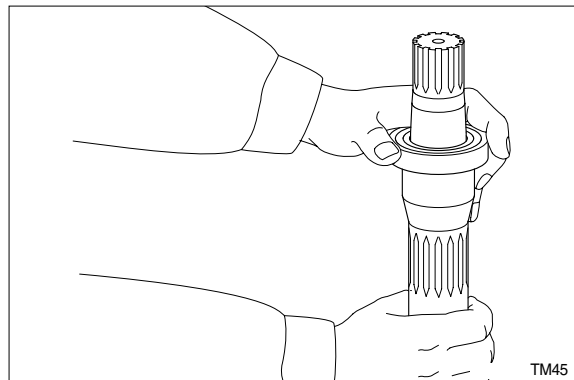

**(8) Assembly of the piston assembly (161, 162)**

- ① Mount the piston assembly(161, 162) in the piston hole of the spindle(2).

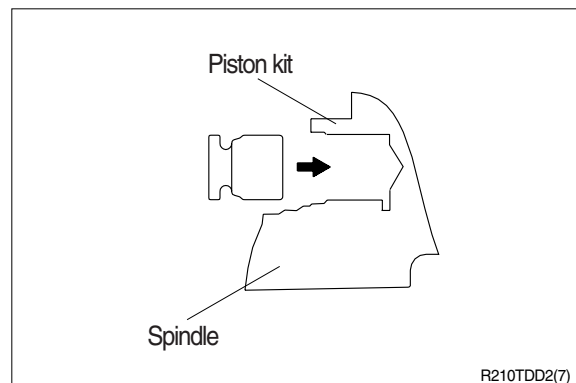
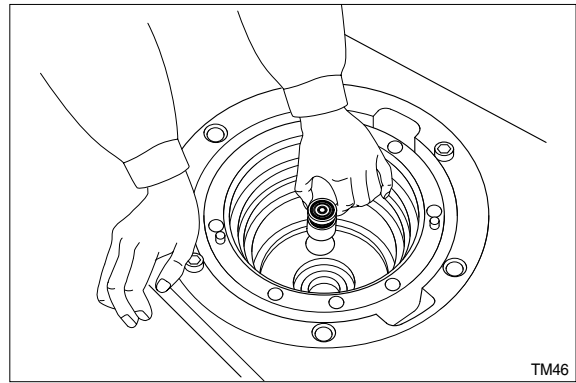

**(9) Assembly of the pivot(167)**

- ① Mount the two parallel pin(168) and two pivot(167) in the pivot hole of the spindle(2).

**(10) Assembly of cylinder block section**

- ① Insert washer(110), spring(114), washer(110) and snap ring(145) in that order, into the shaft bore of cylinder block(104).

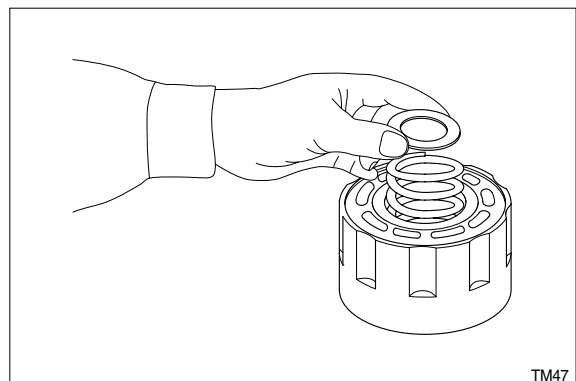



- ② Set cylinder block in the press in order to compress the spring(114).

Place retainer on the washer(110) and push down this tool with the press arbor until the snap ring groove becomes cleared.

Fit snap ring(145) into the groove.

- ※ When working on the cylinder block, protect its sliding face by covering it with a vinyl sheet.
- ※ A push of about 120 kgf(265 lbf) will be needed to compress the spring.

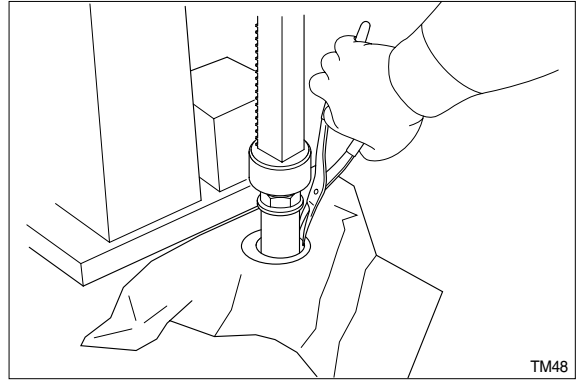

### (11) Assembly of piston motor sub assembly

- ① Fit six rollers(151) into the pin holes of cylinder block(104), and then, put thrust ball(108) on it.

- ※ Immerse piston assembly in hydraulic oil.

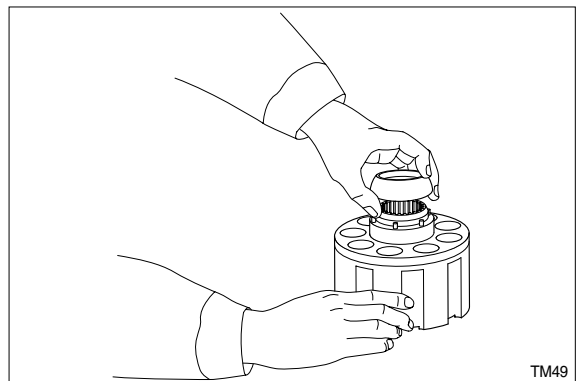

- ② Insert piston assembly into retainer plate(107).

- ③ Mount the piston assembly in the cylinder block(104).

After mounting, immerse the entire them in a working fluid.

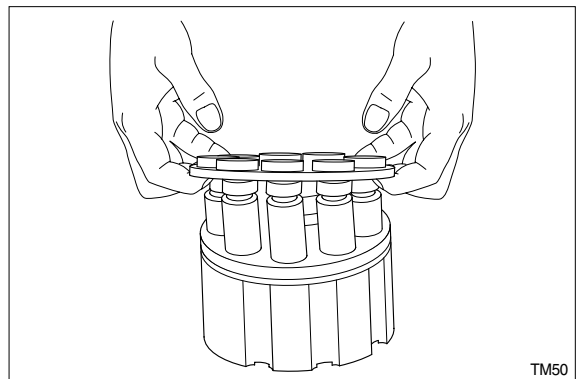

- ④ As shown in the figure, mount the swash plate(103), the thrust plate(153), the thrust ball(108), the retainer plate(107), the roller(151), the cylinder block(104), and the piston assembly (105,106) in the shaft(102).

Then, mount a lifter(Ⅱ) and make the shaft(102) upright.

- ※ The outer lacing of the roller bearing (149) must be mounted in the spindle(2) beforehand.
- ※ Accurately align and assemble the retainer plate(107) and the spherical section of the thrust ball(108).

- ⑤ Lift the motor assembly using a lifter, and mount it in the spindle(2).

- ※ Mounting must be done so that the steel-ball hole in the swash plate(103) and the steel ball(167) come into a fit. Mounting must also be done gently so that no parts come into contact with the spindle(2) or other sections.

Contact may damage parts.

- ※ After the motor assembly has been mounted, turn the cylinder block by hand to check for backlash. Perform inspections if back-lash is present.

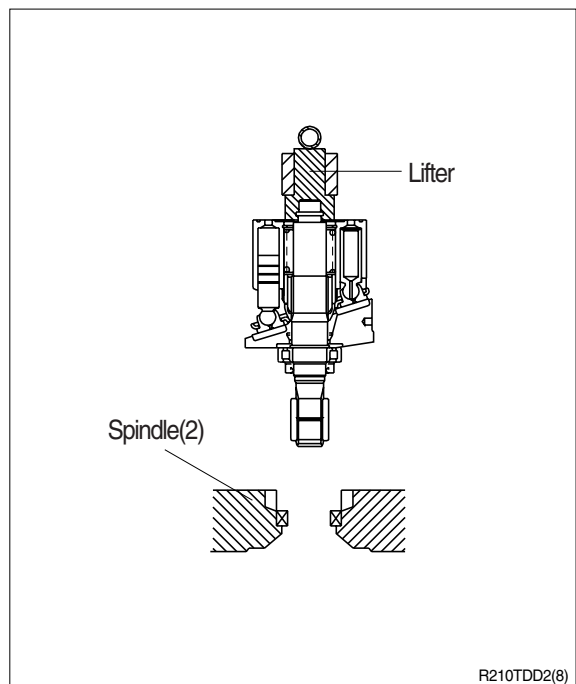
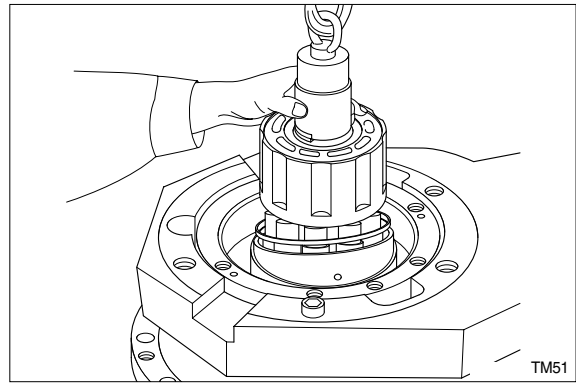

**(12) Assembly of the parking brake section**

- ① Fit the mating plate(116) first and then the friction plate(115), one by one, into the grooves of the outer surface of the cylinder block(104).
- ※ Immerse the friction plates(115) in a working fluid before fitting them into the grooves.

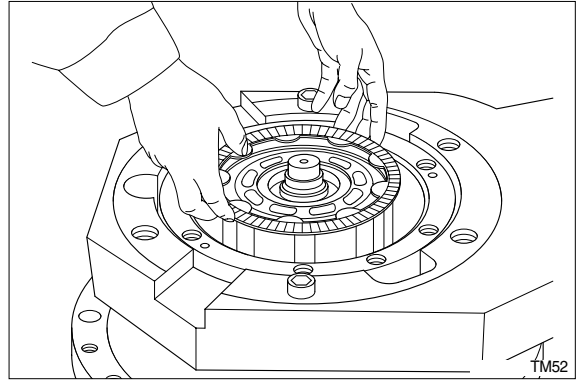

- ② Fit the O-rings(139,178) in the O-ring grooves of the piston(112).
- ※ Apply a thin coat of grease to the O-rings(139,178).

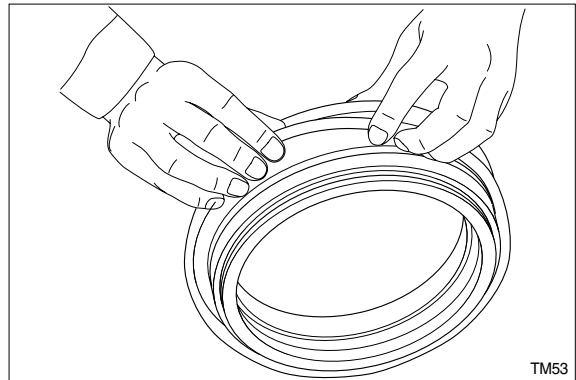

- ③ Mount the piston(112) in the spindle(2).
- If the piston(112) does not fit into the spindle(2) because of the resistance of the O-ring, tap the edge of the piston(112) lightly and equally with a plastic hammer.
- ※ Be careful not to damage the O-ring at this time.

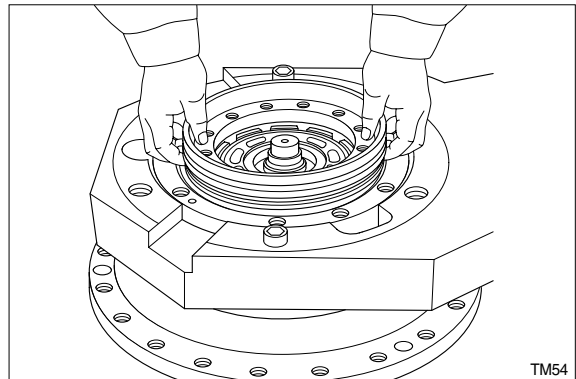

- ④ Mount the ball bearing(150) and timing plate(109) and parallel pin(241) and spring(113) into the rear flange(201).

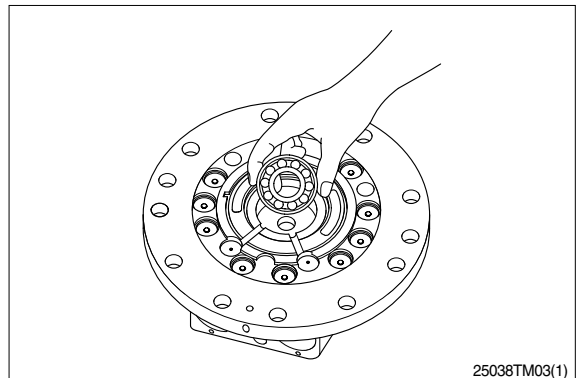

- ⑤ Fit the two O-rings(39) and the O-ring(29) in the O-ring grooves of the spindle(2).

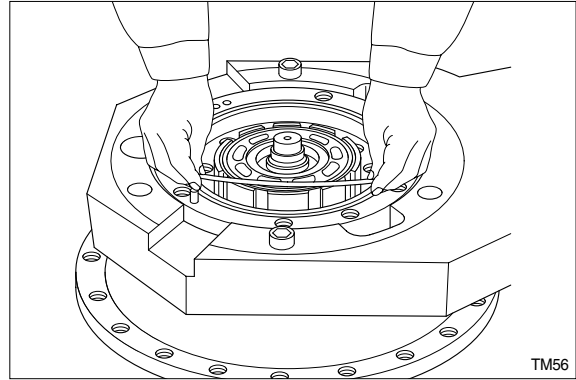

- ⑥ Fill the two dowel pins(181) into the spindle(2).  
Quantity required : 1.2 liters.

- ⑦ Mount the rear flange(101) on the spindle(2).

At this time, the two dowel pins that have been fitted into the spindle(2) must be aligned with the pin holes.

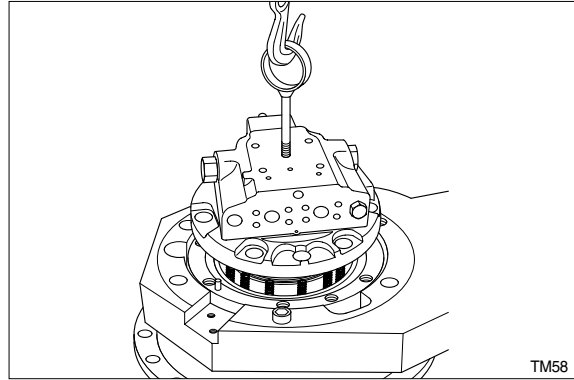

- ⑧ Tighten the nine hexagon socket head bolts(282) into the spindle(2) at the required torque.

※ Tightening torque :

$25.7 \pm 4 \text{ kgf} \cdot \text{m}$  ( $185.9 \pm 28.9 \text{ lbf} \cdot \text{ft}$ )

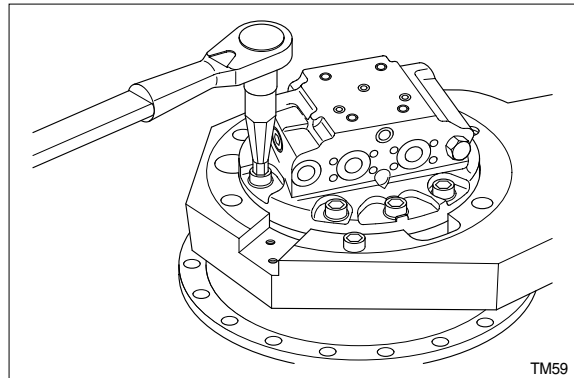

### (13) Assembly of the carrier assembly

- ① Attach one of the two thrust bearing(20) to the coupling gear(8) using grease.
- ※ Apply a thin coat of molybdenum disulfide grease to the thrust bearing(20).

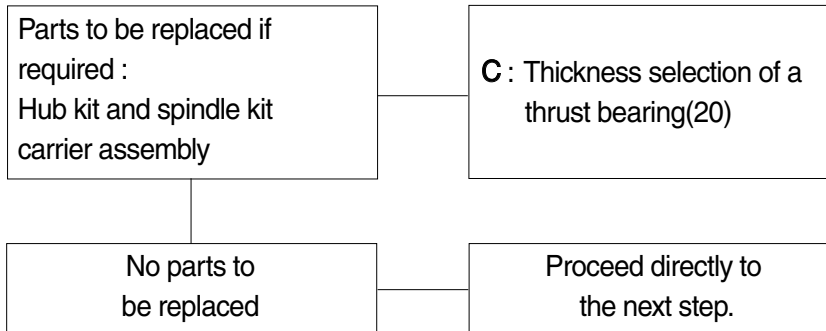

- ② Mount the coupling(19) on the shaft(102).
- ※ Apply a thin coat of molybdenum disulfide grease to the spline section of the coupling(19).

- ③ Place the steel ball(36) in the sun gear(7), and place the sun gear in the coupling(19).

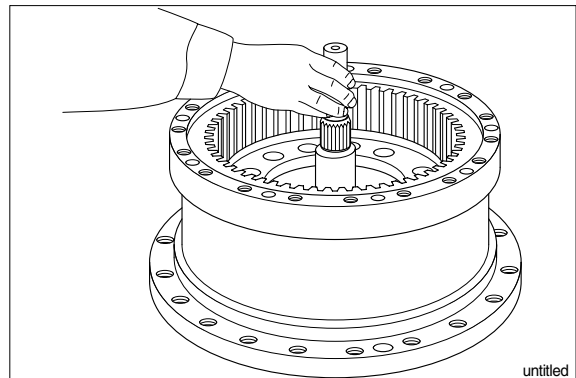

- ④ Insert the carrier assembly into the hub(1), and correctly engage the teeth of ring gear B(5) and teeth B of the cluster gear(6).
- ※ This must be done only after determining the timing point of carrier assembly reassembling (see next for further details).

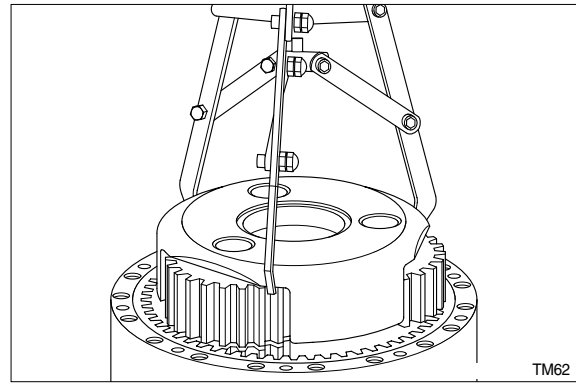

※ **Determining the timing point of carrier assembly reassembling**

To insert the carrier assembly into the hub(1) and correctly engage teeth B of the cluster gear(6) and the teeth of ring gear B(5), carry out the operating procedure described after this figure :

※ **Procedure**

- Align the match marks of the three cluster gears(6) at the positions shown.
- At those positions, engage the sun gear installer correctly with the cluster gears(6) and fix the sun gear installer.
- Insert the carrier assembly into the hub(1). This dismounts the sun gear installer automatically.

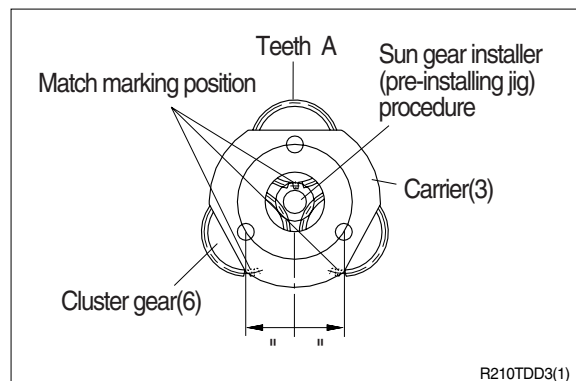

**(14) Assembly of ring gear A(4)**

- ① Mount ring gear A(4) on the hub(1). Check at this time that the teeth of ring gear A and teeth A of the cluster gear are in correct engagement.
- ② Rotate the hub(1) to fit the match marks on ring gear A and the hub.
- ③ Fit the ten dowel pins(27) into the hub(1).
- ※ After completely degreasing that surface of ring A(4) that contacts the hub(1), apply a thin coat #SS60F hermetic sealant to that contact surface.
- ④ Fill the reducer section with a lubricating oil.  
Quantity required : Approx. 3.3 liters

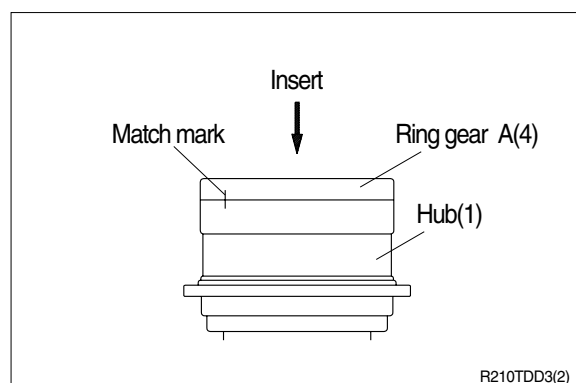

**(15) Assembly of the cover(13)**

- ① Attach the thrust bearing(20) to the carrier(3) using grease.
  - ※ Apply a thin coat of molybdenum disulfide grease to the surface of the thrust bearing(20).
  
- ② Install cover(8) to hub(1).
  - ※ Apply slightly three-bond No.1211 to that matching face of cover which is to mate with the surface of hub(1).

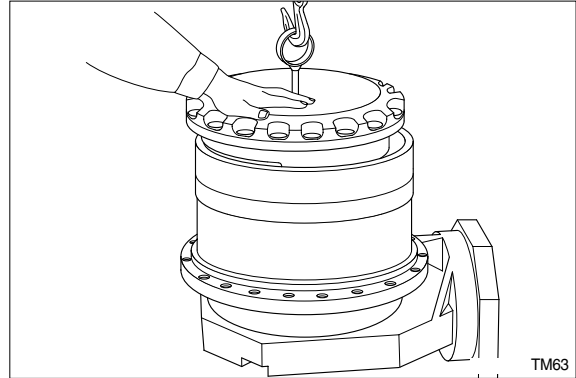

- ③ Fasten cover(13) to hub(1) with 20 hexagonal bolts(32) and 20 supper lock washers(33), applying to the specified torque.
  - ※ Tightening torque :  
 $10.4 \pm 1.6 \text{ kgf} \cdot \text{m}$  ( $75.2 \pm 11.6 \text{ lbf} \cdot \text{ft}$ )
  - ※ Before tightening bolts, apply loctite 242 to the hexagon bolts(32).
- ④ Tighten 3-plugs(30) to cover(13) to the specified torque.
  - ※ Tightening torque :  
 $10 \pm 2 \text{ kgf} \cdot \text{m}$  ( $72.3 \pm 14 \text{ lbf} \cdot \text{ft}$ )
  - ※ Before tightening plugs, wrap the threaded portion of each plug with two lagers of the seal tape.
  - ※ Tighten each plug until the last thread becomes nearly flush with the cover surface within an extent equal to plus or minus one thread relative to the surface.

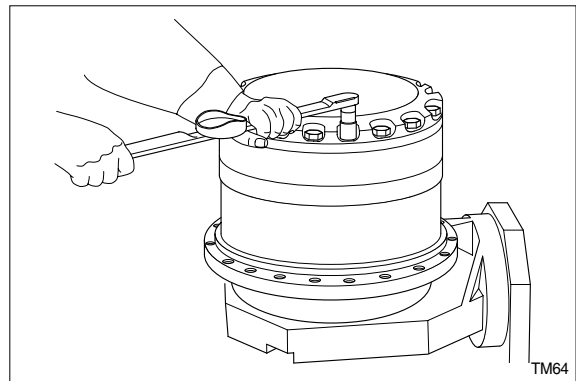



## B: THICKNESS SELECTION OF A DISTANCE PIECE(12)

(1) If the parts listed below have been replaced, select a distance piece(12) of the appropriate thickness.

After selection, return to the original reassembling procedure [procedure (5) of subsection 3] and carry out the next step of that procedure.

Parts replacement — 
{
Hub kit  
Spindle kit  
Ball bearing(24)

(2) Steps(1) through(4) of the original reassembling procedure must be carried out as directed.

① Mount a measure plate on the spindle(2) without inserting a distance piece(12).

② Lightly tighten a few hexagon socket bolts(35).

③ As shown in the figure at right, measure dimension **A** using a depth micrometer.

※ Tighten the hexagon socket head bolts equally.

④ Measure dimension **C** of the coupling gear(8) to be mounted see the figure at right.

⑤ Using the clearance measurements, calculate the appropriate distance piece thickness as follows.

- Measure the clearance between the edge of the spindle(2) and that of the ball bearing(24).

Take this clearance as **X**.

$$X = A - B$$

- Next, determine the distance piece of the appropriate thickness.

Take this thickness as **T**.

$$T = (C + X) \pm 0.1$$

⑥ Using the results of steps (1) through (5) above, select the appropriate thickness.

Then, proceed with the original reassembling operation.

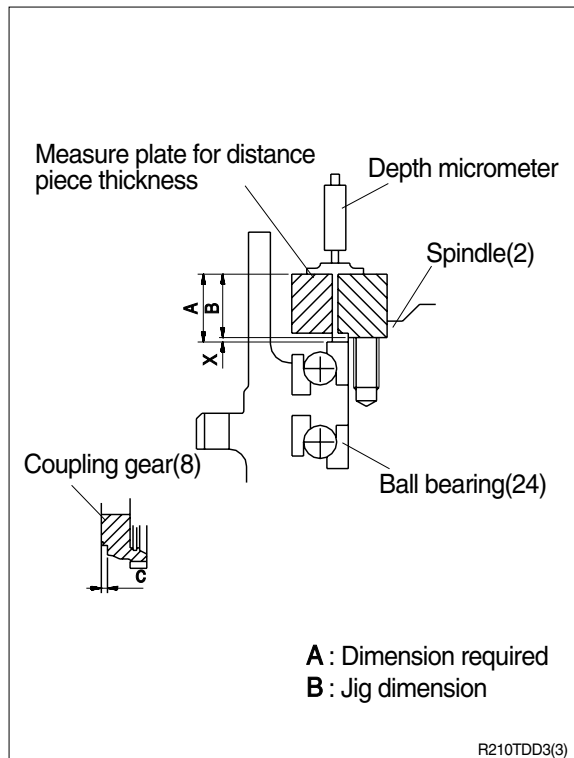
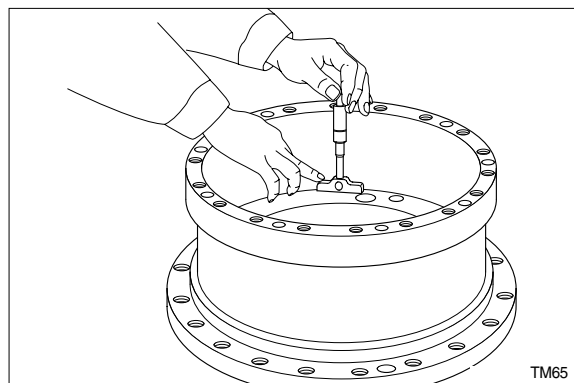

## C: THICKNESS SELECTION OF A THRUST BEARING(20)

- (1) If the parts listed below have been replaced, select a thrust bearing(20) of the appropriate thickness.

After selection, return to the original reassembling procedure [procedure (15) at page 8-113] and carry out the next step of that procedure.

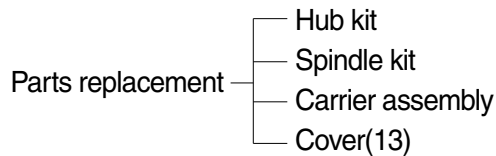

- (2) Steps(1) through(4) of the original reassembling procedure must be carried out as directed.

- ① Attach one of the two thrust bearings(20) to the coupling gear(8).

At this time, use the thinnest distance piece.

- ② Mount the coupling(19) on the shaft(102).

- ③ Place the sun gear(7) in the coupling(19).

- ④ Insert the carrier assembly into the hub(1), and correctly engage the teeth of ring gear B(5) and teeth B of the cluster gear(6).

※ This must be done only after determining the timing point of carrier assembly reassembling (see next for further details.)

※ Do not apply molybdenum disulfide grease to the thrust bearing(20).

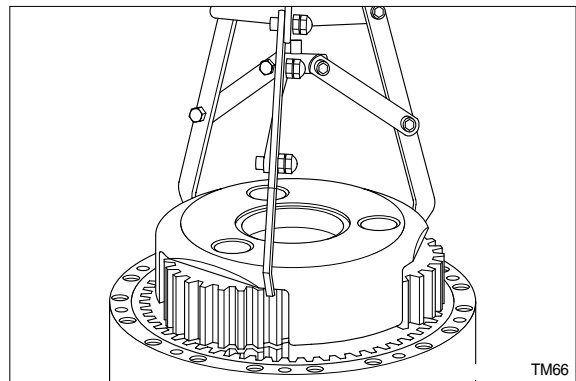

- ⑤ Fit the match marks on ring gear A(4) and the hub(1), and mount the ring gear on the hub. Check at this time that teeth A of the cluster gear(6) and the teeth of ring gear A(4) are in correct engagement.

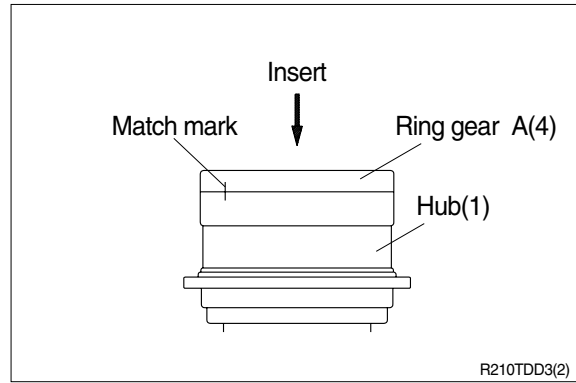

- ⑥ Mount a thrust-bearing adjusting plate on the hub(1), and lightly tighten the former using two M12 hexagon socket bolts.

※ Do not mount the thrust bearing(20) at this time.

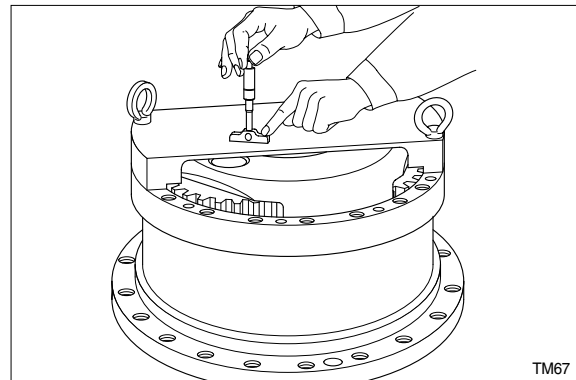

- ⑦ As shown in the figure at right, measure dimension **A** using a depth micrometer.

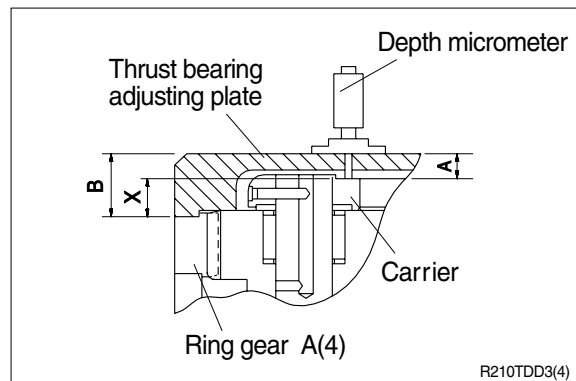

- ⑧ Measure dimension **C** of the cover(13) to be mounted. See the figure at right.

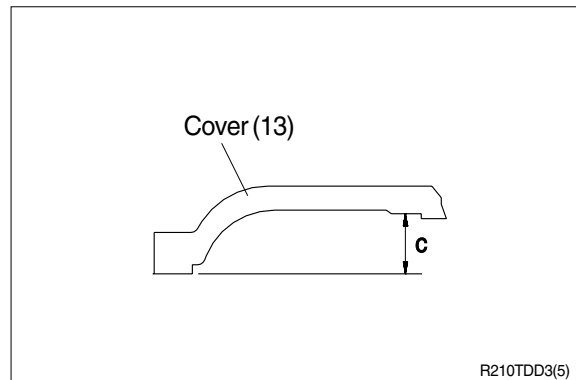

- ⑨ Using the clearance measurements, calculate the appropriate thrust bearing thickness as follows.
- Measure the clearance between the edge of the carrier(3) and that of ring gear A(4).  
Take this clearance as **X**  
**X = B - A**  
**A** : Dimension required  
**B** : Jig dimension
  - Next, determine the thrust bearing of the appropriate thickness.  
Take this thickness as **T**.  
**T = (C - X) - (0.3 to 0.6)**
- ⑩ Using the results of steps(7) through(9) above,select the appropriate thickness from three types.  
Then, proceed with the original reassembling operation.