

GROUP 2 MODE SELECTION SYSTEM(up to #1000)

1. POWER MODE SELECTION SYSTEM

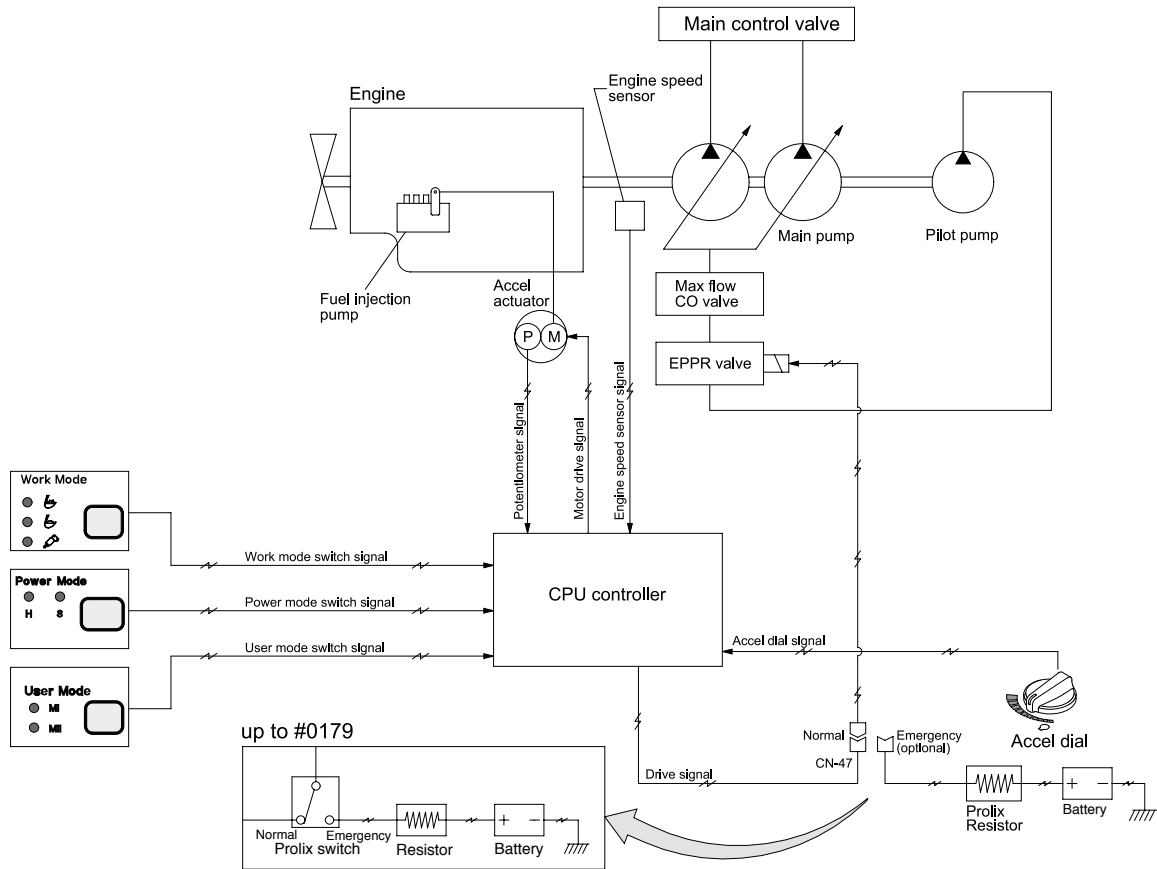

21075MS02

Mode selection system(Micro computer based electro-hydraulic pump and engine mutual control system) optimizes the engine and pump performance.

The combination of 2 power modes(H, S) and accel dial position(10 set) makes it possible to use the engine and pump power more effectively corresponding to the work conditions from a heavy and great power requesting work to a light and precise work.

Mode	Application	Power set (%)	Engine rpm		Power shift by EPPR valve			
					Ver 1. X(STD)		Ver 2. X(OPT)	
			Unload	Load	Current (mA)	Pressure (kgf/cm ²)	Current (mA)	Pressure (kgf/cm ²)
H	High power	100	2250 ± 50	2100	160 ± 30	0	430	18
S	Standard power	85	2150 ± 50	2000	370 ± 30	13	480	22
AUTO DECEL	Engine deceleration	-	1200 ± 100	-	670 ± 30	31	670 ± 30	31
One touch decel	Engine quick deceleration	-	950 ± 100	-	710 ± 30	35	710 ± 30	35
KEY START	Key switch start position	-	950 ± 100	-	710 ± 30	35	710 ± 30	35

2. WORK MODE SELECTION SYSTEM

3 work modes can be selected for the optional work speed of the machine operation.

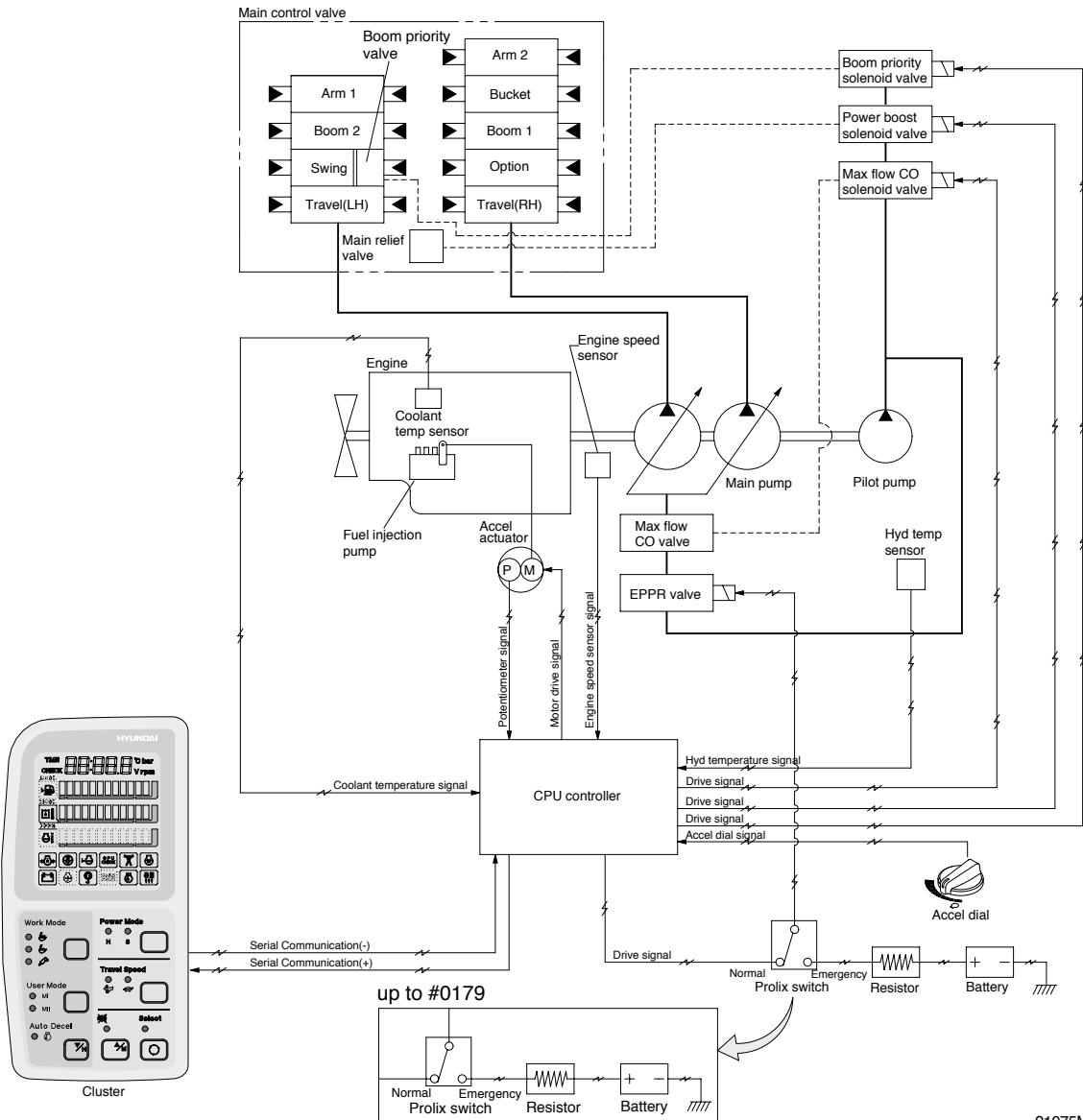

21075MS03

1) HEAVY DUTY WORK MODE

The boom priority solenoid is activated to make the boom operation speed faster.

2) GENERAL WORK MODE

When key switch is turned ON, this mode is selected and swing operation speed is faster than heavy duty work mode.

3) BREAKER OPERATION MODE

It sets the pump flow to the optimal operation of breaker by activating the max flow cut-off solenoid.

Work mode	Boom priority solenoid	Max flow cut-off solenoid
Heavy duty	ON	OFF
General	OFF	OFF
Breaker	OFF	ON

3. USER MODE SELECTION SYSTEM

Through 2 memory sets of MI and MII, an operator can change the engine and pump power and memorize it for his preference.

Mode	Operation
MI (Memory mode 1)	High idle rpm, auto decel rpm
MII (Memory mode 2)	EPPR pressure can be modulated and memorized separately

HOW TO MODULATE THE MEMORY SET

- Each memory mode has a initial set which are mid-range of max engine speed, auto decel rpm, and EPPR valve input current. When you select MI or MII, cluster LCD displays.
- To change the engine high idle speed, press the USER mode switch and SELECT switch at the same time and then ACCEL blinks at 0.5 seconds interval.
 - By pressing ▲ or ▼ switch, █ will increase or decrease.
- To change DECEL rpm, press the USER mode switch and SELECT switch once more and then DECEL blinks at 0.5 seconds interval.
 - By pressing ▲ or ▼ switch, █ will increase or decrease.
- To change EPPR current, press the USER mode switch and SELECT switch one more and then EPPR blinks at 0.5 seconds interval.
 - By pressing ▲ or ▼ switch, █ will increase or decrease.

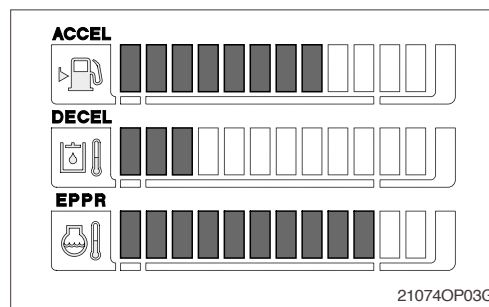

• LCD segment vs parameter setting

Segment (█)	ACCEL (rpm)	DECEL (rpm)	EPPR (mA)	
1	High idle-900	Low idle		150
		950	*1050	
2	High idle-800	1050	*1100	200
3	High idle-700	1100	*1150	250
4	High idle-600	1150	Decel rpm *1200	300
5	High idle-500	Decel rpm 1200	*1250	350
6	High idle-400	1250	*1300	400
7	High idle-300	1300	*1350	450
8	High idle-200	1350	*1400	500
9	High idle-100	1400	*1450	550
10	High idle	1500	*1500	600

* : TIER II only

- To memorize the final setting, press the USER mode switch and SELECT switch one more time.

