

GROUP 7 TRAVEL CONTROL SYSTEM

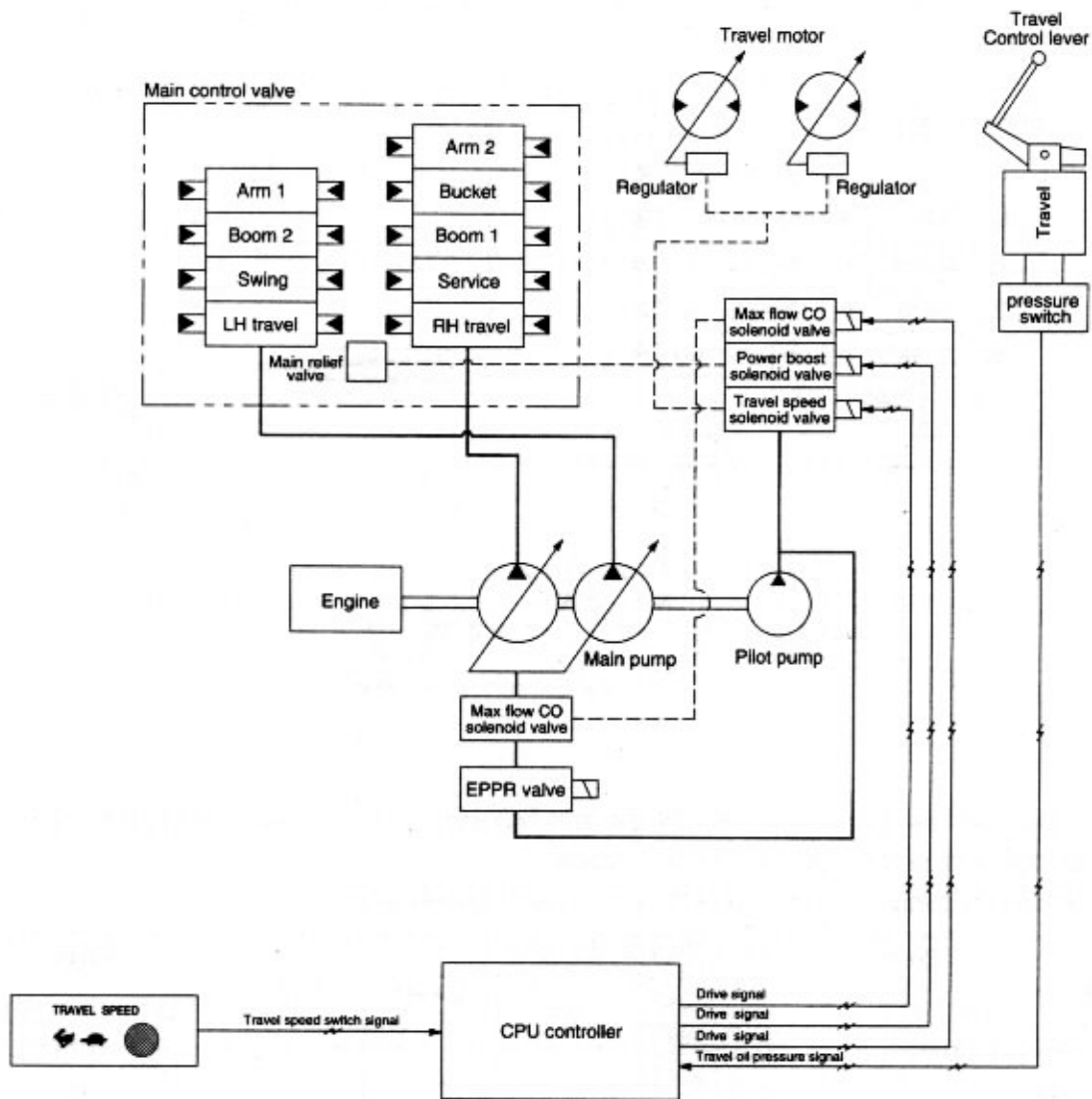

1. TRAVEL SPEED SELECTION

Travel speed can be switched manually by pressing the travel speed switch on the cluster.

Speed	Travel speed solenoid valve	Lamp on cluster	Operation
Lo	OFF	Turtle	Low speed, high driving torque in travel motors
Hi	ON	Rabbit	High speed, low driving torque in travel motors

* Default : Turtle(Lo)

2. POWER BOOST IN TRAVEL

When the operation of travel control levers is detected by travel oil pressure switch, CPU controller sends control signal to set the pressure of the main relief valve from 320kg/cm² to 350kg/cm² to increase travel power.