

GROUP 3 PILOT CIRCUIT

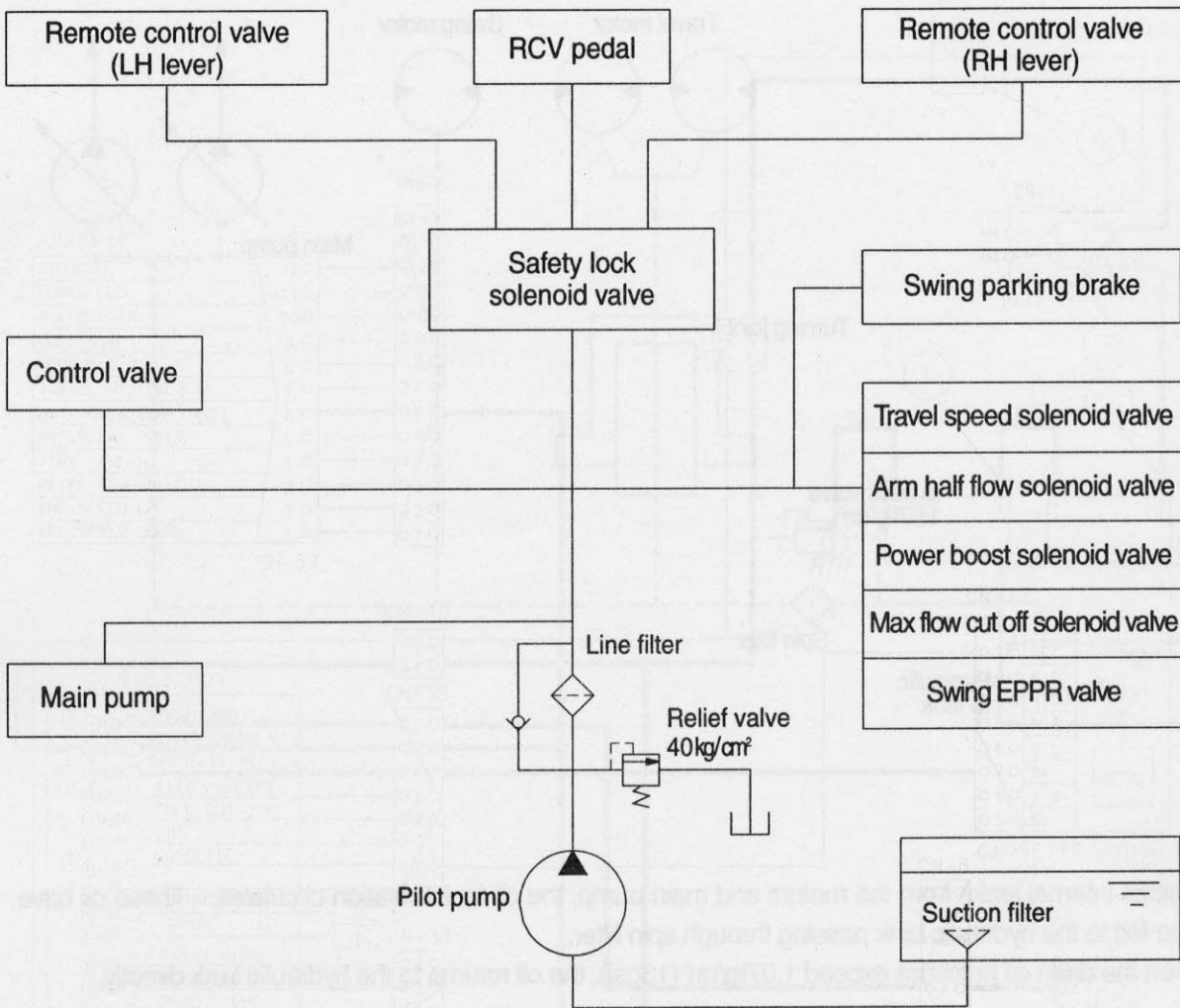

The pilot circuit consists of suction circuit, delivery circuit and return circuit.

The pilot pump is provided with relief valve, receives the oil from the hydraulic tank through the suction filter.

The discharged oil from the pilot pump flows to the remote control valve through line filter, EPPR valve, solenoid valve assemblies, swing parking brake, main control valve and safety lock solenoid valve.

2. SAFETY VALVE(SAFETY LEVER)

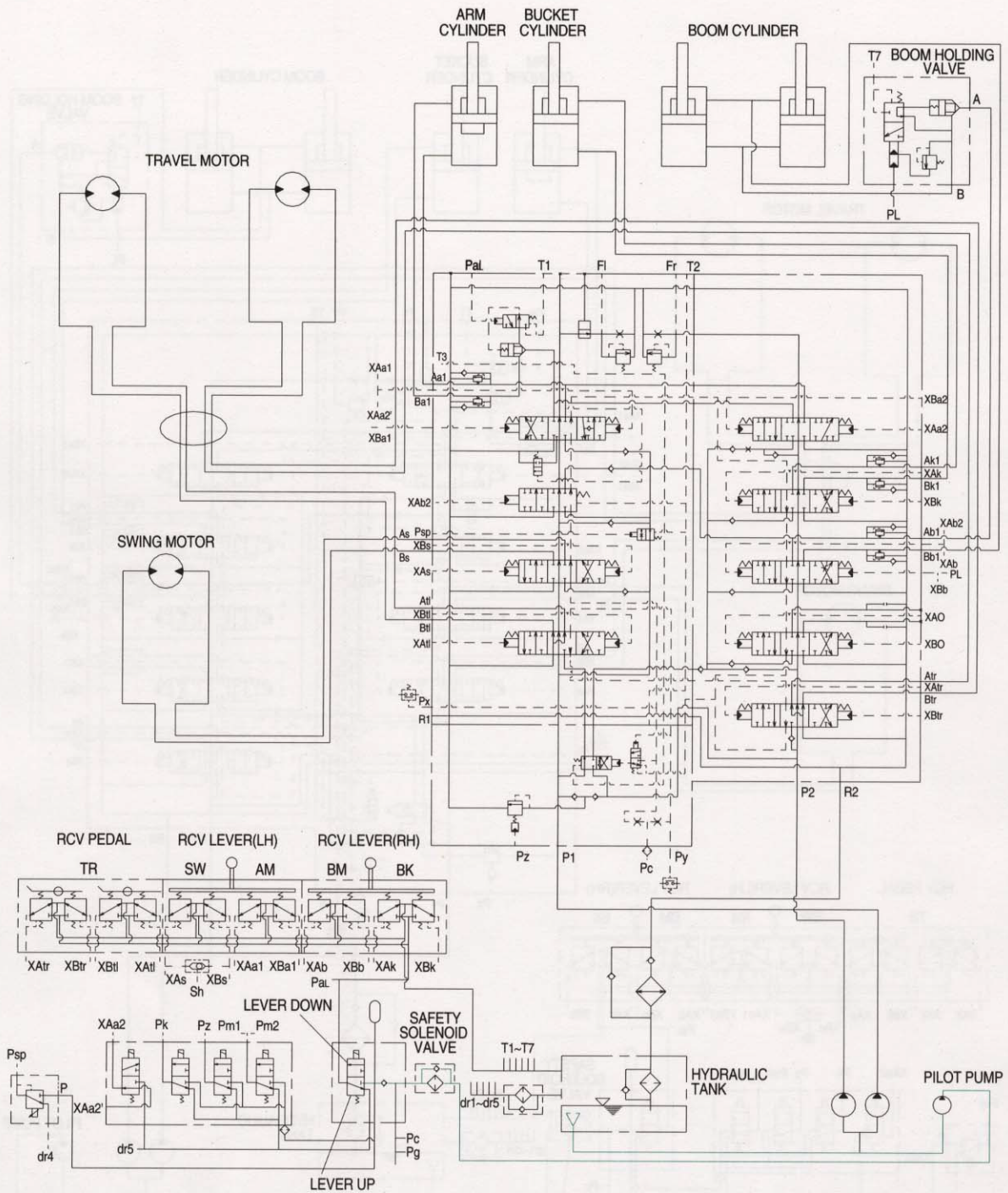

When the lever of the safety solenoid valve is moved downward, oil flows into the remote control valve through solenoid valve and line filter.

When the lever of the safety solenoid valve is moved upward, oil does not flow into the remote control valve, because of the blocked port.

3. ARM HALF FLOW SYSTEM

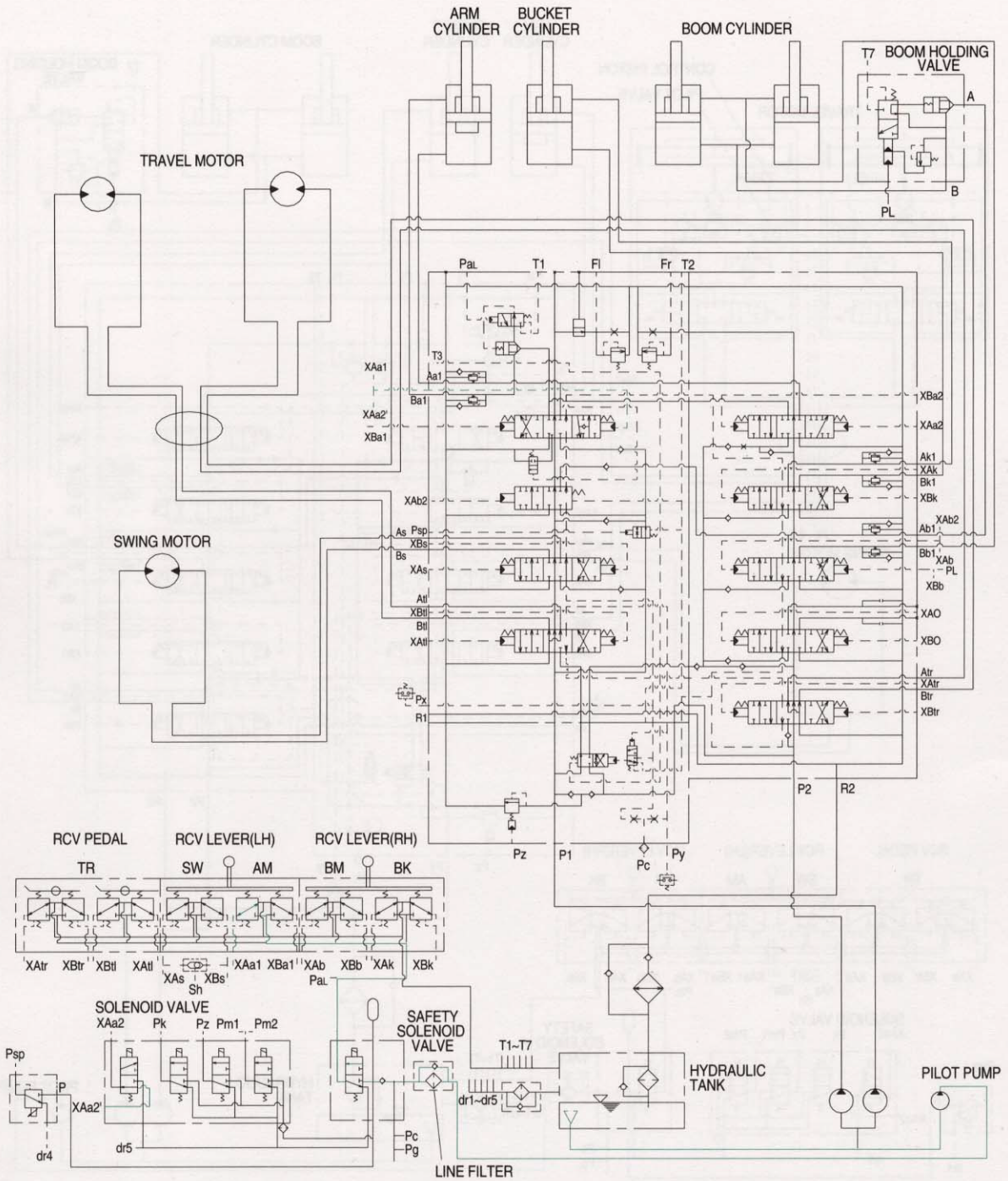

When the arm half flow switch is turned ON, the arm half flow solenoid valve is switched to ON and it cancels oil flow from XAa1 to XAa2 : so the spool of arm 2 is not actuated. As a result, the arm in operation is only the arm 1 section. This function is useful to fine control of the arm in case of finishing work.

5. MAIN RELIEF PRESSURE CHANGE SYSTEM

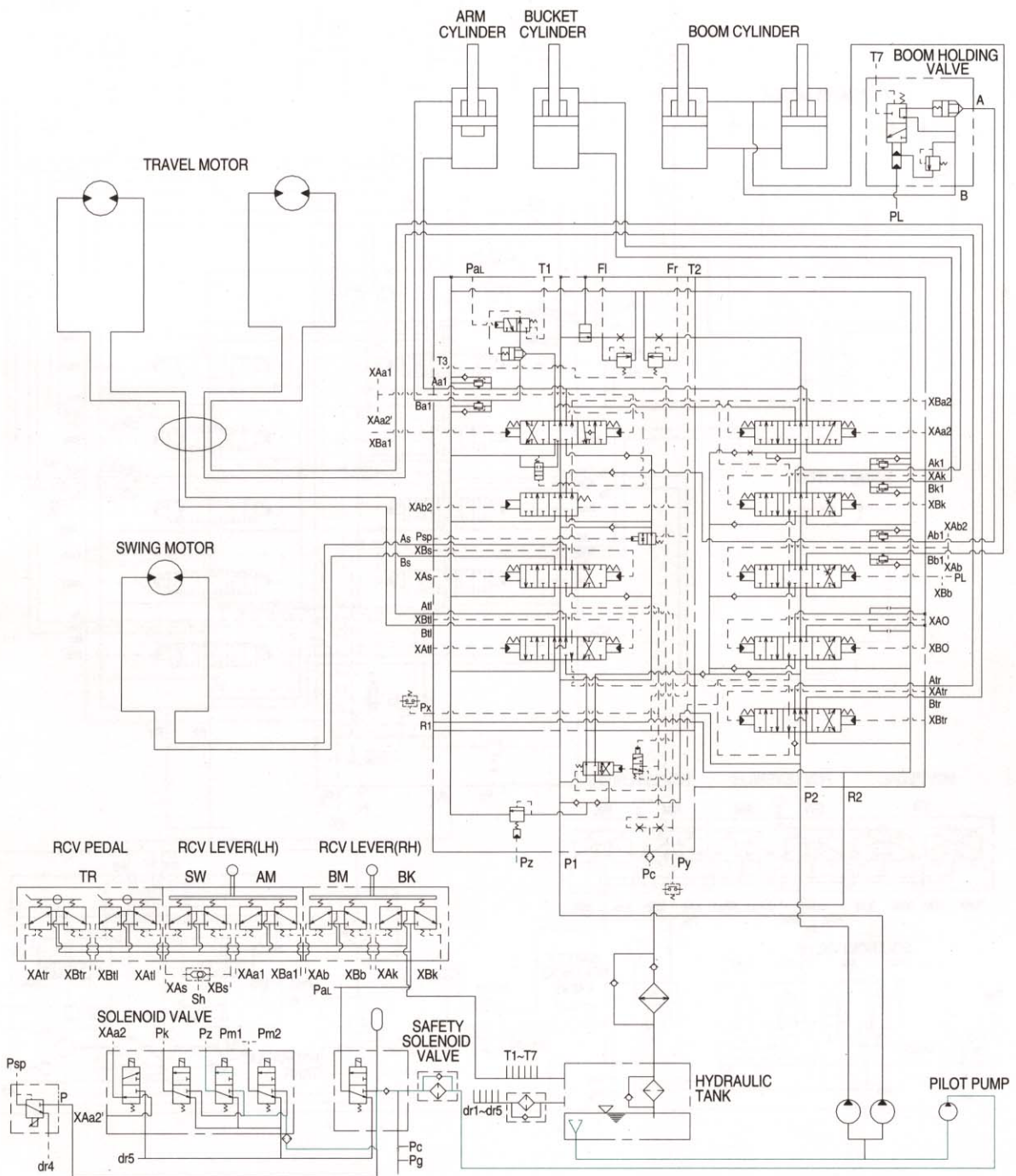

When the power boost switch on the left control lever is pushed ON, the power boost solenoid valve is actuated, the discharged oil from the pilot pump flows into Pz port of the main relief valve of main control valve; then the setting pressure of the main relief valve is raised from 320kgf/cm² to 350kgf/cm² for increasing the digging power. And even when pressed continuously, it is canceled after 8 seconds.

7. SWING PARKING BRAKE RELEASE

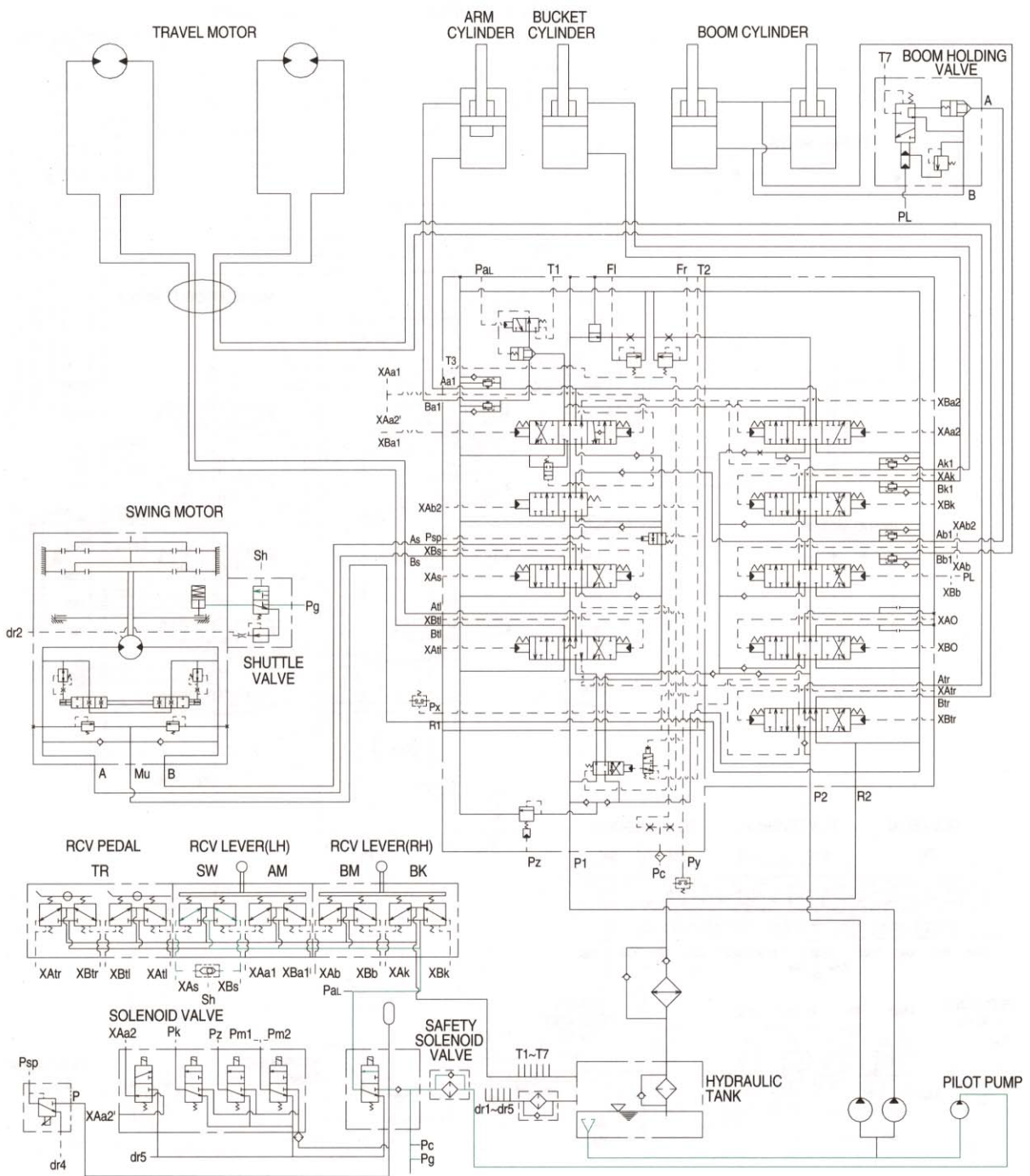

When the swing control lever is tilted, the pilot oil goes to Sh port of shuttle valve, this pressure move spool so, discharged oil from pilot valve goes to Pg port.

This pressure is applied to swing motor disc, thus the brake is released.

When the swing control lever is set in the neutral position, oil in the motor disc cylinder is drained, thus the brake is applied.

8. SWING PRIORITY SYSTEM

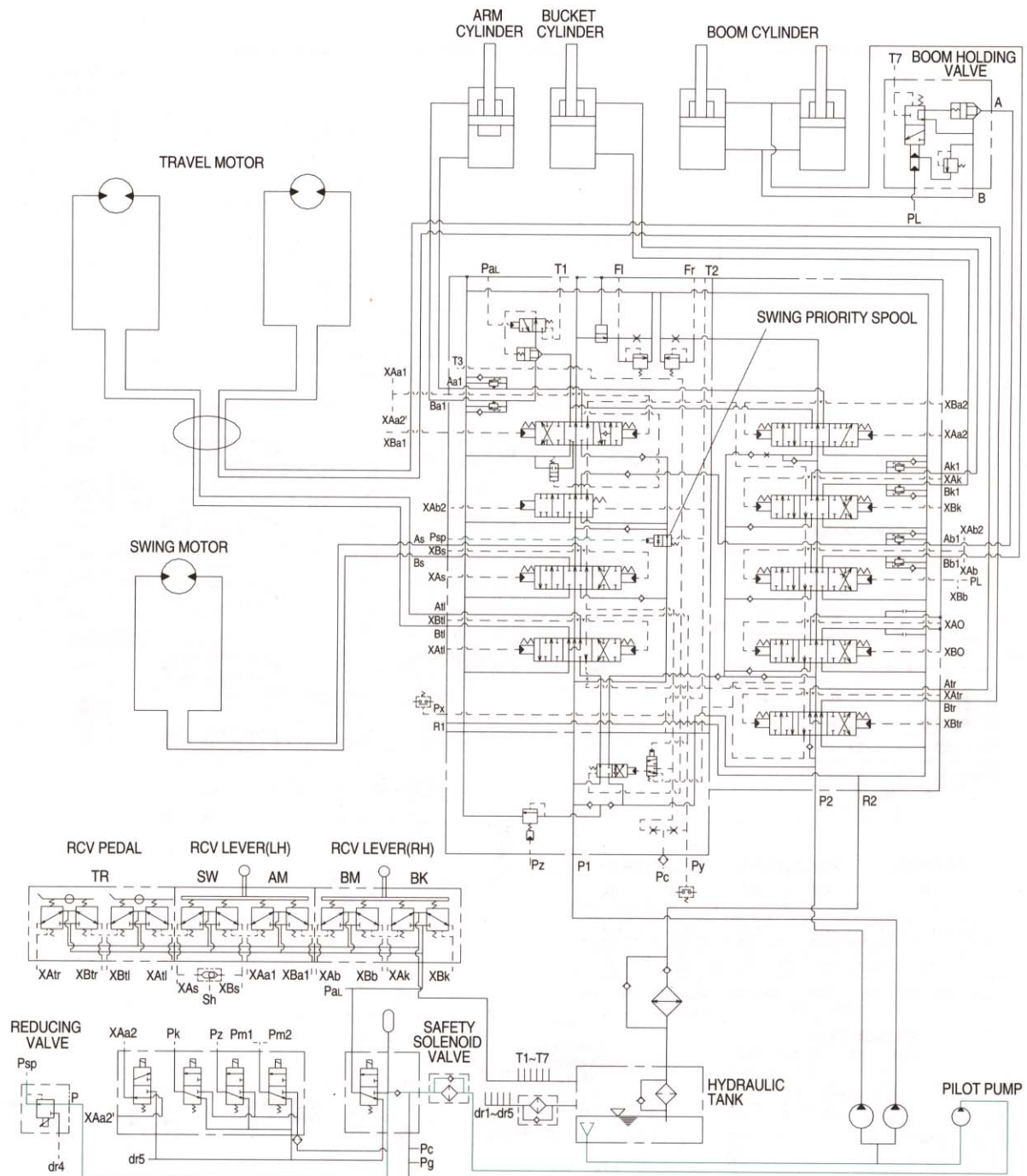

When carrying out the combined operation of swing and boom or arm of the left control valve, the swing speed can be lowered than operating speed of boom or arm. To prevent it, reducing valve is used.

The oil from pilot pump flows into the reducing valve through the line filter.

Psp pressure from reducing valve shifts the swing priority spool to the right and decreases the oil flow rate to the boom or arm section by orifice.

This is called the swing priority system.